

Advance Information

MPC8260EC/D
Rev. 1.1 05/2002

MPC8260 (HiP3)
Hardware Specifications



This document contains detailed information on power considerations, DC/AC electrical characteristics, and AC timing specifications for the HiP3 version of the PowerQUICC II™ MPC8260 communications processor .

The following topics are addressed:

Topic	Page
Section 1.1, “Features”	2
Section 1.2, “Electrical and Thermal Characteristics”	5
Section 1.2.1, “DC Electrical Characteristics”	5
Section 1.2.2, “Thermal Characteristics”	9
Section 1.2.3, “Power Considerations”	9
Section 1.2.4, “AC Electrical Characteristics”	10
Section 1.3, “Clock Configuration Modes”	17
Section 1.3.1, “Local Bus Mode”	17
Section 1.4, “Pinout”	20
Section 1.5, “Package Description”	33
Section 1.6, “Ordering Information”	35

Features

Figure 1 shows the block diagram for the MPC8260.

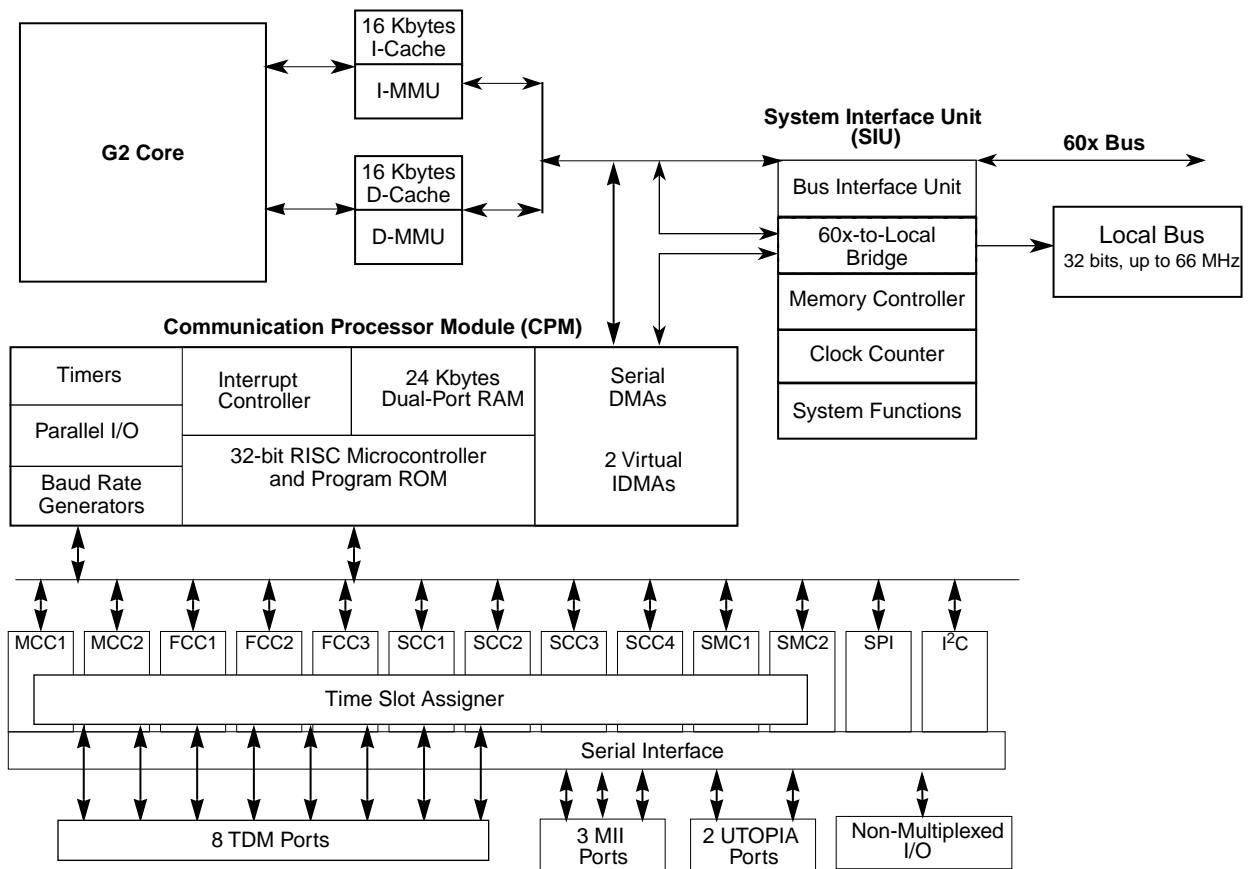

Figure 1. MPC8260 Block Diagram

1.1 Features

The major features of the MPC8260 are as follows:

- Dual-issue integer core
 - A core version of the EC603e microprocessor
 - System core microprocessor supporting frequencies of 133–200 MHz
 - Separate 16-Kbyte data and instruction caches:
 - Four-way set associative
 - Physically addressed
 - LRU replacement algorithm
 - PowerPC architecture-compliant memory management unit (MMU)
 - Common on-chip processor (COP) test interface
 - High-performance (4.4–5.1 SPEC95 benchmark at 200 MHz; 280 Dhrystones MIPS at 200 MHz)
 - Supports bus snooping for data cache coherency
 - Floating-point unit (FPU)
- Separate power supply for internal logic and for I/O

- Separate PLLs for G2 core and for the CPM
 - G2 core and CPM can run at different frequencies for power/performance optimization
 - Internal core/bus clock multiplier that provides 1.5:1, 2:1, 2.5:1, 3:1, 3.5:1, 4:1, 5:1, 6:1 ratios
 - Internal CPM/bus clock multiplier that provides 2:1, 2.5:1, 3:1, 3.5:1, 4:1, 5:1, 6:1 ratios
- 64-bit data and 32-bit address 60x bus
 - Bus supports multiple master designs
 - Supports single- and four-beat burst transfers
 - 64-, 32-, 16-, and 8-bit port sizes controlled by on-chip memory controller
 - Supports data parity or ECC and address parity
- 32-bit data and 18-bit address local bus
 - Single-master bus, supports external slaves
 - Eight-beat burst transfers
 - 32-, 16-, and 8-bit port sizes controlled by on-chip memory controller
- System interface unit (SIU)
 - Clock synthesizer
 - Reset controller
 - Real-time clock (RTC) register
 - Periodic interrupt timer
 - Hardware bus monitor and software watchdog timer
 - IEEE 1149.1 JTAG test access port
- Twelve-bank memory controller
 - Glueless interface to SRAM, page mode SDRAM, DRAM, EPROM, Flash and other user-definable peripherals
 - Byte write enables and selectable parity generation
 - 32-bit address decodes with programmable bank size
 - Three user programmable machines, general-purpose chip-select machine, and page-mode pipeline SDRAM machine
 - Byte selects for 64 bus width (60x) and byte selects for 32 bus width (local)
 - Dedicated interface logic for SDRAM
- CPU core can be disabled and the device can be used in slave mode to an external core
- Communications processor module (CPM)
 - Embedded 32-bit communications processor (CP) uses a RISC architecture for flexible support for communications protocols
 - Interfaces to G2 core through on-chip 24-Kbyte dual-port RAM and DMA controller
 - Serial DMA channels for receive and transmit on all serial channels
 - Parallel I/O registers with open-drain and interrupt capability
 - Virtual DMA functionality executing memory-to-memory and memory-to-I/O transfers
 - Three fast communications controllers supporting the following protocols:
 - 10/100-Mbit Ethernet/IEEE 802.3 CDMA/CS interface through media independent interface (MII)

Features

- ATM—Full-duplex SAR protocols at 155 Mbps, through UTOPIA interface, AAL5, AAL1, AAL0 protocols, TM 4.0 CBR, VBR, UBR, ABR traffic types, up to 16 K external connections
- Transparent
- HDLC—Up to T3 rates (clear channel)
- Two multichannel controllers (MCCs)
 - Each MCC handles 128 serial, full-duplex, 64-Kbps data channels. Each MCC can be split into four subgroups of 32 channels each.
 - Almost any combination of subgroups can be multiplexed to single or multiple TDM interfaces up to four TDM interfaces per MCC
- Four serial communications controllers (SCCs) identical to those on the MPC860, supporting the digital portions of the following protocols:
 - Ethernet/IEEE 802.3 CDMA/CS
 - HDLC/SDLC and HDLC bus
 - Universal asynchronous receiver transmitter (UART)
 - Synchronous UART
 - Binary synchronous (BISYNC) communications
 - Transparent
- Two serial management controllers (SMCs), identical to those of the MPC860
 - Provide management for BRI devices as general circuit interface (GCI) controllers in time-division-multiplexed (TDM) channels
 - Transparent
 - UART (low-speed operation)
- One serial peripheral interface identical to the MPC860 SPI
- One inter-integrated circuit (I²C) controller (identical to the MPC860 I²C controller)
 - Microwire compatible
 - Multiple-master, single-master, and slave modes
- Up to eight TDM interfaces
 - Supports two groups of four TDM channels for a total of eight TDMs
 - 2,048 bytes of SI RAM
 - Bit or byte resolution
 - Independent transmit and receive routing, frame synchronization
 - Supports T1, CEPT, T1/E1, T3/E3, pulse code modulation highway, ISDN basic rate, ISDN primary rate, Motorola interchip digital link (IDL), general circuit interface (GCI), and user-defined TDM serial interfaces
- Eight independent baud rate generators and 20 input clock pins for supplying clocks to FCCs, SCCs, SMCs, and serial channels
- Four independent 16-bit timers that can be interconnected as two 32-bit timers

1.2 Electrical and Thermal Characteristics

This section provides AC and DC electrical specifications and thermal characteristics for the MPC8260.

1.2.1 DC Electrical Characteristics

This section describes the DC electrical characteristics for the MPC8260. Table 1 shows the maximum electrical ratings.

Table 1. Absolute Maximum Ratings¹

Rating	Symbol	Value	Unit
Core supply voltage ²	VDD	-0.3 – 2.75	V
PLL supply voltage ²	VCCSYN	-0.3 – 2.75	V
I/O supply voltage ³	VDDH	-0.3 – 4.0	V
Input voltage ⁴	VIN	GND(-0.3) – 3.6	V
Junction temperature	T _j	120	°C
Storage temperature range	T _{STG}	(-55) – (+150)	°C

¹ Absolute maximum ratings are stress ratings only; functional operation (see Table 2) at the maximums is not guaranteed. Stress beyond those listed may affect device reliability or cause permanent damage.

² **Caution:** VDD/VCCSYN must not exceed VDDH by more than 0.4 V at any time, including during power-on reset.

³ **Caution:** VDDH can exceed VDD/VCCSYN by 3.3 V during power on reset by no more than 100 mSec. VDDH should not exceed VDD/VCCSYN by more than 2.0 V during normal operation.

⁴ **Caution:** VIN must not exceed VDDH by more than 2.5 V at any time, including during power-on reset.

Table 2 lists recommended operational voltage conditions.

Table 2. Recommended Operating Conditions¹

Rating	Symbol	2.5-V Device ²	Unit
Core supply voltage	VDD	2.4–2.7	V
PLL supply voltage	VCCSYN	2.4–2.7	V
I/O supply voltage	VDDH	3.135 – 3.465	V
Input voltage	VIN	GND (-0.3) – 3.465	V
Junction temperature (maximum)	T _j	105	°C

¹ **Caution:** These are the recommended and tested operating conditions. Proper device operating outside of these conditions is not guaranteed.

² Parts labeled with an “-HVA” suffix are 2.6-V devices.

NOTE

VDDH and VDD must track each other and both must vary in the same direction—in the positive direction (+5% and +0.1 Vdc) or in the negative direction (-5% and -0.1 Vdc).

Electrical and Thermal Characteristics

This device contains circuitry protecting against damage due to high static voltage or electrical fields; however, it is advised that normal precautions be taken to avoid application of any voltages higher than maximum-rated voltages to this high-impedance circuit. Reliability of operation is enhanced if unused inputs are tied to an appropriate logic voltage level (either GND or V_{CC}).

Table 3 shows DC electrical characteristics.

Table 3. DC Electrical Characteristics

Characteristic	Symbol	Min	Max	Unit
Input high voltage, all inputs except CLKIN	V_{IH}	2.0	3.465	V
Input low voltage	V_{IL}	GND	0.8	V
CLKIN input high voltage	V_{IHC}	2.4	3.465	V
CLKIN input low voltage	V_{ILC}	GND	0.4	V
Input leakage current, $V_{IN} = V_{DDH}^1$	I_{IN}	—	10	μA
Hi-Z (off state) leakage current, $V_{IN} = V_{DDH}^1$	I_{OZ}	—	10	μA
Signal low input current, $V_{IL} = 0.8$ V	I_L	—	1	μA
Signal high input current, $V_{IH} = 2.0$ V	I_H	—	1	μA
Output high voltage, $I_{OH} = -2$ mA except XFC, UTOPIA mode, and open drain pins In UTOPIA mode: $I_{OH} = -8.0$ mA PA[0-31] PB[4-31] PC[0-31] PD[4-31]	V_{OH}	2.4	—	V
In UTOPIA mode: $I_{OL} = 8.0$ mA PA[0-31] PB[4-31] PC[0-31] PD[4-31]	V_{OL}	—	0.5	V

Table 3. DC Electrical Characteristics (Continued)

Characteristic	Symbol	Min	Max	Unit
$I_{OL} = 7.0\text{mA}$ BR \overline{BG} ABB/IRQ2 \overline{TS} A[0-31] TT[0-4] TBST TSIZE[0-3] \overline{AACK} \overline{ARTRY} \overline{DBG} DBB/IRQ3 D[0-63] DP(0)/RSRV/EXT_BR2 DP(1)/IRQ1/EXT_BG2 DP(2)/TLBISYNC/IRQ2/EXT_DBG2 DP(3)/IRQ3/EXT_BR3/CKSTP_OUT DP(4)/IRQ4/EXT_BG3/CORE_SREST DP(5)/TBEN/IRQ5/EXT_DBG3 DP(6)/CSE(0)/IRQ6 DP(7)/CSE(1)/IRQ7 \overline{PSDVAL} \overline{TA} TEA GBL/IRQ1 CT/BADDR29/IRQ2 WT/BADDR30/IRQ3 L2_HIT/IRQ4 CPU_BG/BADDR31/IRQ5 CPU_DBG CPU_BR IRQ0/NMI_OUT IRQ7/INT_OUT/APE $\overline{PORESET}$ \overline{HRESET} \overline{SRESET} RSTCONF QREQ	V_{OL}	—	0.4	V

Electrical and Thermal Characteristics

Table 3. DC Electrical Characteristics (Continued)

Characteristic	Symbol	Min	Max	Unit
$I_{OL} = 5.3\text{mA}$ $\overline{CS}[0-9]$ $\overline{CS}(10)/\overline{BCTL1}$ $\overline{CS}(11)/\overline{AP}(0)$ $\overline{BADDR}[27-28]$ \overline{ALE} $\overline{BCTL0}$ $\overline{PWE}(0:7)/\overline{PSDDQM}(0:7)/\overline{PBS}(0:7)$ $\overline{PSDA10}/\overline{PGPL0}$ $\overline{PSDWE}/\overline{PGPL1}$ $\overline{POE}/\overline{PSDRAS}/\overline{PGPL2}$ $\overline{PSDCAS}/\overline{PGPL3}$ $\overline{PGTA}/\overline{PUPMWAIT}/\overline{PGPL4}/\overline{PPBS}$ $\overline{PSDAMUX}/\overline{PGPL5}$ $\overline{LWE}[0-3]/\overline{LSDDQM}[0:3]/\overline{LBS}[0-3]$ $\overline{LSDA10}/\overline{LGPL0}$ $\overline{LSDWE}/\overline{LGPL1}$ $\overline{LOE}/\overline{LSDRAS}/\overline{LGPL2}$ $\overline{LSDCAS}/\overline{LGPL3}$ $\overline{LGTA}/\overline{LUPMWAIT}/\overline{LGPL4}/\overline{LPBS}$ $\overline{LSDAMUX}^2/\overline{LGPL5}$ \overline{LWR} $\overline{MODCK1}/\overline{AP}(1)/\overline{TC}(0)/\overline{BNKSEL}(0)$ $\overline{MODCK2}/\overline{AP}(2)/\overline{TC}(1)/\overline{BNKSEL}(1)$ $\overline{MODCK3}/\overline{AP}(3)/\overline{TC}(2)/\overline{BNKSEL}(2)$	V_{OL}	—	0.4	V
$I_{OL} = 3.2\text{mA}$ $\overline{L_A14}$ $\overline{L_A15}/\overline{SMI}$ $\overline{L_A16}$ $\overline{L_A17}/\overline{CKSTP_OUT}$ $\overline{L_A18}$ $\overline{L_A19}$ $\overline{L_A20}$ $\overline{L_A21}$ $\overline{L_A22}$ $\overline{L_A23}$ $\overline{L_A24}$ $\overline{L_A25}$ $\overline{L_A26}$ $\overline{L_A27}$ $\overline{L_A28}/\overline{CORE_SRESET}$ $\overline{L_A29}$ $\overline{L_A30}$ $\overline{L_A31}$ $\overline{LCL_D}(0-31)$ $\overline{LCL_DP}(0-3)$ $\overline{PA}[0-31]$ $\overline{PB}[4-31]$ $\overline{PC}[0-31]$ $\overline{PD}[4-31]$ \overline{TDO}				

¹ The leakage current is measured for nominal VDDH and VDD or both VDDH and VDD must vary in the same direction; that is, VDDH and VDD either both vary in the positive direction (+5% and +0.1 Vdc) or both vary in the negative direction (-5% and -0.1 Vdc).

² Only Rev C.2 silicon.

1.2.2 Thermal Characteristics

Table 4 describes thermal characteristics.

Table 4. Thermal Characteristics

Characteristics	Symbol	Value	Unit	Air Flow
Thermal resistance for TBGA	θ_{JA}	13.07 ¹	°C/W	NC ²
	θ_{JA}	9.55 ¹	°C/W	1 m/s
	θ_{JA}	10.48 ³	°C/W	NC
	θ_{JA}	7.78 ³	°C/W	1 m/s

¹ Assumes a single layer board with no thermal vias

² Natural convection

³ Assumes a four layer board

1.2.3 Power Considerations

The average chip-junction temperature, T_J , in °C can be obtained from the following:

$$T_J = T_A + (P_D \times \theta_{JA}) \quad (1)$$

where

T_A = ambient temperature °C

θ_{JA} = package thermal resistance, junction to ambient, °C/W

$P_D = P_{INT} + P_{I/O}$

$P_{INT} = I_{DD} \times V_{DD}$ Watts (chip internal power)

$P_{I/O}$ = power dissipation on input and output pins (determined by user)

For most applications $P_{I/O} < 0.3 \times P_{INT}$. If $P_{I/O}$ is neglected, an approximate relationship between P_D and T_J is the following:

$$P_D = K / (T_J + 273^\circ \text{C}) \quad (2)$$

Solving equations (1) and (2) for K gives:

$$K = P_D \times (T_A + 273^\circ \text{C}) + \theta_{JA} \times P_D^2 \quad (3)$$

where K is a constant pertaining to the particular part. K can be determined from equation (3) by measuring P_D (at equilibrium) for a known T_A . Using this value of K, the values of P_D and T_J can be obtained by solving equations (1) and (2) iteratively for any value of T_A .

1.2.3.1 Layout Practices

Each V_{CC} pin should be provided with a low-impedance path to the board's power supply. Each ground pin should likewise be provided with a low-impedance path to ground. The power supply pins drive distinct groups of logic on chip. The V_{CC} power supply should be bypassed to ground using at least four 0.1 μF by-pass capacitors located as close as possible to the four sides of the package. The capacitor leads and associated printed circuit traces connecting to chip V_{CC} and ground should be kept to less than half an inch per capacitor lead. A four-layer board is recommended, employing two inner layers as V_{CC} and GND planes.

Electrical and Thermal Characteristics

All output pins on the MPC8260 have fast rise and fall times. Printed circuit (PC) trace interconnection length should be minimized in order to minimize overdamped conditions and reflections caused by these fast output switching times. This recommendation particularly applies to the address and data buses. Maximum PC trace lengths of six inches are recommended. Capacitance calculations should consider all device loads as well as parasitic capacitances due to the PC traces. Attention to proper PCB layout and bypassing becomes especially critical in systems with higher capacitive loads because these loads create higher transient currents in the V_{CC} and GND circuits. Pull up all unused inputs or signals that will be inputs during reset. Special care should be taken to minimize the noise levels on the PLL supply pins.

Table 5 provides preliminary, estimated power dissipation for various configurations. Note that suitable thermal management is required for conditions above $P_D = 3W$ (when the ambient temperature is $70^\circ C$ or greater) to ensure the junction temperature does not exceed the maximum specified value. Also note that the I/O power should be included when determining whether to use a heat sink.

Table 5. Estimated Power Dissipation for Various Configurations¹

Bus (MHz)	CPM Multiplier	CPU Multiplier	CPM (MHz)	CPU (MHz)	$P_{INT} (W)^2$				
					Vddl				
					2.4	2.5	2.6	2.7	2.8 ³
33.3	4	4	133.3	133.3	2.04	2.14	2.26	2.38	2.50
50.0	2	3	100	150.0	2.21	2.30	2.45	2.59	2.69
66.7	2	2.5	133.3	166.7	2.47	2.62	2.74	2.88	3.02
66.7	2.5	2.5	166.7	166.7	2.57	2.69	2.83	2.98	3.12
66.7	2	3	133.3	200.0	2.81	2.95	3.12	3.29	3.43
66.7	2.5	3	166.7	200.0	2.88	3.05	3.22	3.38	3.55
50.0	3	4	150	200.0	2.83	3.00	3.14	3.31	3.48

¹ Test temperature = room temperature ($25^\circ C$)

² $P_{INT} = I_{DD} \times V_{DD}$ Watts

³ 2.8 Vddl does not apply to HiP3 Rev C silicon.

1.2.4 AC Electrical Characteristics

The following sections include illustrations and tables of clock diagrams, signals, and CPM outputs and inputs for the 66 MHz MPC8260 device. Note that AC timings are based on a 50-pf load. Typical output buffer impedances are shown in Table 6.

Table 6. Output Buffer Impedances¹

Output Buffers	Typical Impedance (Ω)
60x bus	40
Local bus	40
Memory controller	40
Parallel I/O	46

¹ These are typical values at $65^\circ C$. The impedance may vary by $\pm 25\%$ with process and temperature.

Table 7 lists CPM output characteristics.

Table 7. AC Characteristics for CPM Outputs¹

Spec_num Max/Min	Characteristic	Max Delay (ns)	Min Delay (ns)
		66 MHz	66 MHz
sp36a/sp37a	FCC outputs—internal clock (NMSI)	6	1
sp36b/sp37b	FCC outputs—external clock (NMSI)	14	2
sp40/sp41	TDM outputs/SI	25	5
sp38a/sp39a	SCC/SMC/SPI/I2C outputs—internal clock (NMSI)	19	1
sp38b/sp39b	Ex_SCC/SMC/SPI/I2C outputs—external clock (NMSI)	19	2
sp42/sp43	PIO/TIMER/DMA outputs	14	1

¹ Output specifications are measured from the 50% level of the rising edge of CLKIN to the 50% level of the signal. Timings are measured at the pin.

Table 8 lists CPM input characteristics.

Table 8. AC Characteristics for CPM Inputs¹

Spec_num	Characteristic	Setup (ns)	Hold (ns)
		66 MHz	66 MHz
sp16a/sp17a	FCC inputs—internal clock (NMSI)	10	0
sp16b/sp17b	FCC inputs—external clock (NMSI)	3	3
sp20/sp21	TDM inputs/SI	15	12
sp18a/sp19a	SCC/SMC/SPI/I2C inputs—internal clock (NMSI)	20	0
sp18b/sp19b	SCC/SMC/SPI/I2C inputs—external clock (NMSI)	5	5
sp22/sp23	PIO/TIMER/DMA inputs	10	3

¹ Input specifications are measured from the 50% level of the signal to the 50% level of the rising edge of CLKIN. Timings are measured at the pin.

Note that although the specifications generally reference the rising edge of the clock, the following AC timing diagrams also apply when the falling edge is the active edge.

Electrical and Thermal Characteristics

Figure 2 shows the FCC external clock.

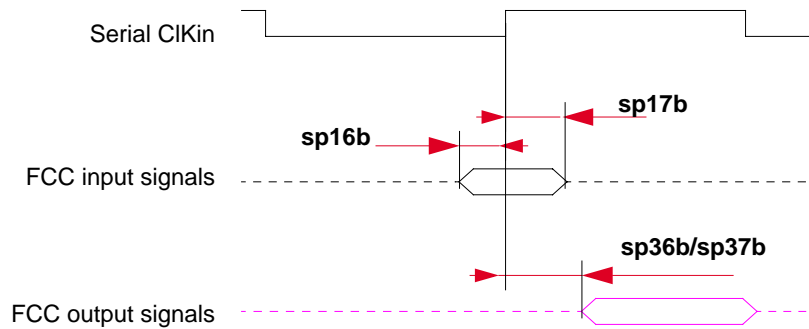

Figure 2. FCC External Clock Diagram

Figure 3 shows the FCC internal clock.

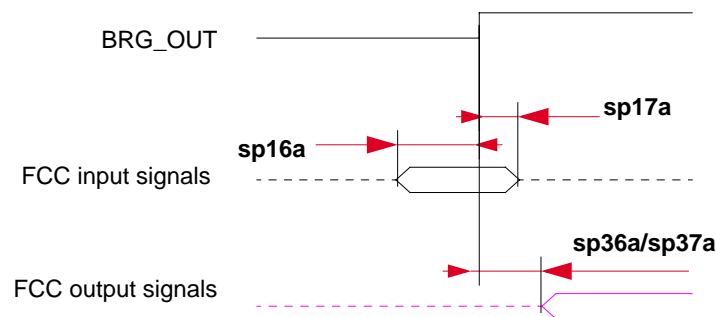

Figure 3. FCC Internal Clock Diagram

Figure 4 shows the SCC/SMC/SPI/I²C external clock.

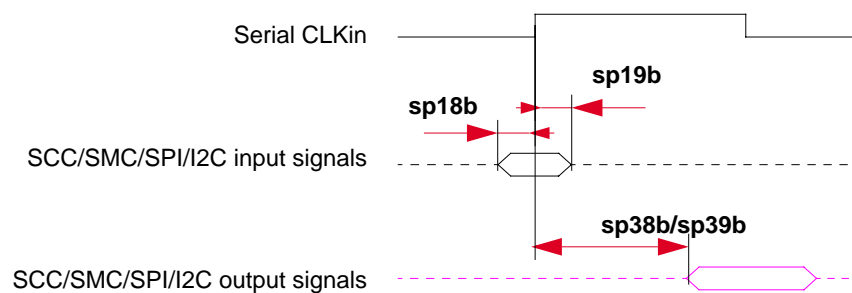

Figure 4. SCC/SMC/SPI/I²C External Clock Diagram

Figure 5 shows the SCC/SMC/SPI/I²C internal clock.

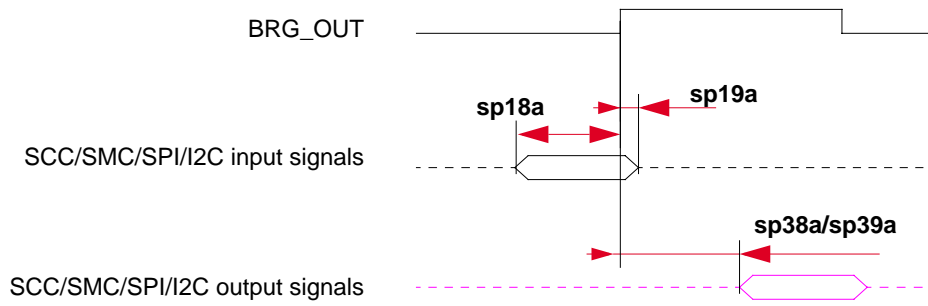

Figure 5. SCC/SMC/SPI/I²C Internal Clock Diagram

Figure 6 shows PIO, timer, and DMA signals.

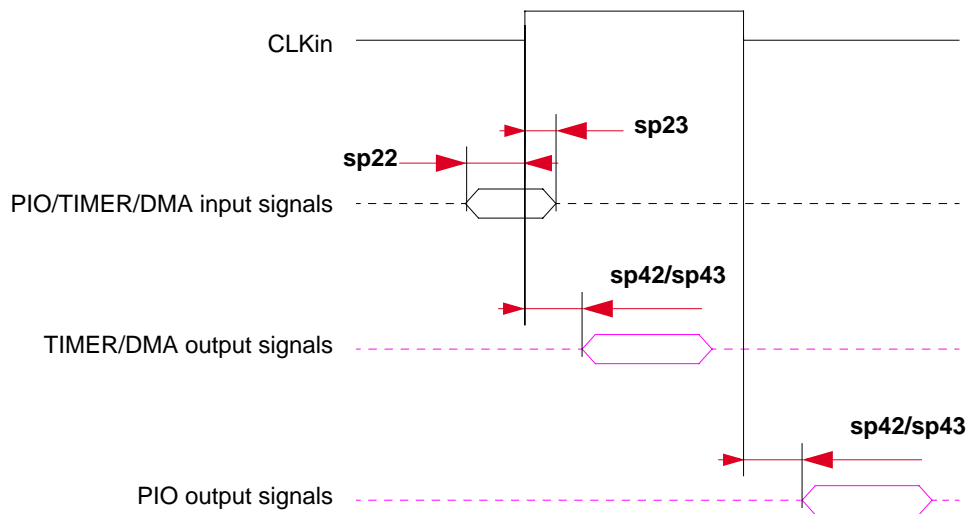

Figure 6. PIO, Timer, and DMA Signal Diagram

Table 9 lists SIU input characteristics.

Table 9. AC Characteristics for SIU Inputs¹

Spec_num	Characteristic	Setup (ns) Hold (ns)	
		66 MHz	66 MHz
sp11/sp10	AACK/ARTRY/T \bar{A} /TS/TEA/DBG/BG/BR	6	1
sp12/sp10	Data bus in normal mode	5	1
sp13/sp10	Data bus in ECC and PARITY modes	8	1
sp14/sp10	DP pins	8	1
sp15/sp10	All other pins	5	1

¹ Input specifications are measured from the 50% level of the signal to the 50% level of the rising edge of CLKIN. Timings are measured at the pin.

Electrical and Thermal Characteristics

Table 10 lists SIU output characteristics.

Table 10. AC Characteristics for SIU Outputs¹

Spec_num Max/Min	Characteristic	Max Delay (ns)	Min Delay (ns)
		66 MHz	66 MHz
sp31/sp30	PSDVAL/TEA/TĀ	10	0.5
sp32/sp30	ADD/ADD_atr./BADDR/CI/GBL/WT	8	0.5
sp33a/sp30	Data bus	8	0.5
sp33b/sp30	DP	12	0.5
sp34/sp30	memc signals/ALE	6	0.5
sp35/sp30	all other signals	7.5	0.5

¹ Output specifications are measured from the 50% level of the rising edge of CLKIN to the 50% level of the signal. Timings are measured at the pin.

Activating data pipelining (setting BR_x[DR] in the memory controller) improves the AC timing. When data pipelining is activated, sp12 can be used for data bus setup even when ECC or PARITY are used. Also, sp33a can be used as the AC specification for DP signals.

Figure 7 shows TDM input and output signals.

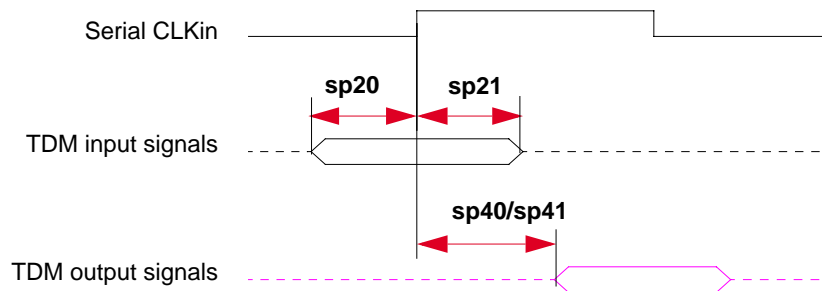

Figure 7. TDM Signal Diagram

Figure 8 shows the interaction of several bus signals.

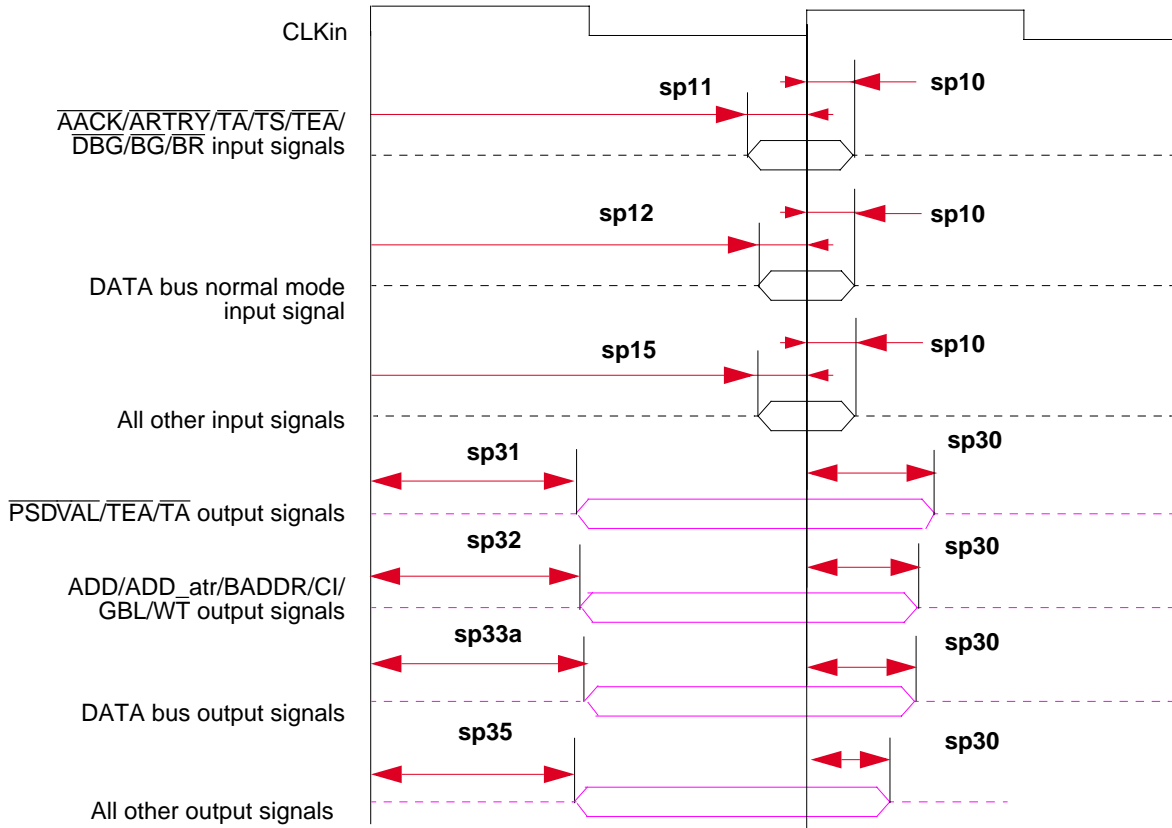

Figure 8. Bus Signals

Figure 9 shows signal behavior for all parity modes (including ECC, RMW parity, and standard parity).

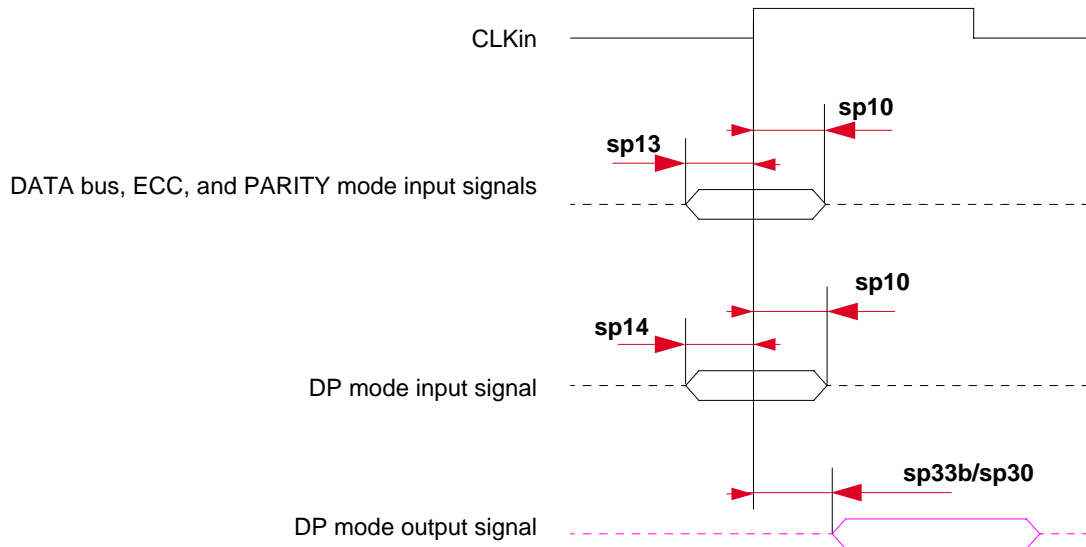

Figure 9. Parity Mode Diagram

Figure 10 shows signal behavior in MEMC mode.

Electrical and Thermal Characteristics

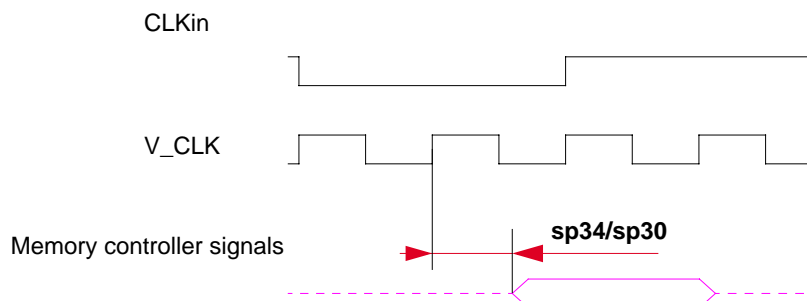

Figure 10. MEMC Mode Diagram

NOTE

Generally, all MPC8260 bus and system output signals are driven from the rising edge of the input clock (CLKIn). Memory controller signals, however, trigger on four points within a CLKIn cycle. Each cycle is divided by four internal ticks: T1, T2, T3, and T4. T1 always occurs at the rising edge, and T3 at the falling edge, of CLKIn. However, the spacing of T2 and T4 depends on the PLL clock ratio selected, as shown in Table 11.

Table 11. Tick Spacing for Memory Controller Signals

PLL Clock Ratio	Tick Spacing (T1 Occurs at the Rising Edge of CLKIn)		
	T2	T3	T4
1:2, 1:3, 1:4, 1:5, 1:6	1/4 CLKIn	1/2 CLKIn	3/4 CLKIn
1:2.5	3/10 CLKIn	1/2 CLKIn	8/10 CLKIn
1:3.5	4/14 CLKIn	1/2 CLKIn	11/14 CLKIn

Figure 11 is a graphical representation of Table 11.

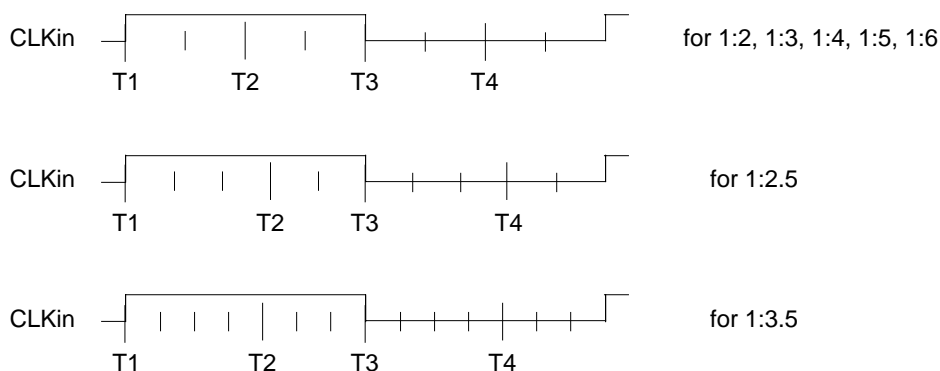

Figure 11. Internal Tick Spacing for Memory Controller Signals

NOTE

The UPM machine outputs change on the internal tick determined by the memory controller programming; the AC specifications are relative to the internal tick. Note that SDRAM and GPCM machine outputs change on CLKIn's rising edge.

1.3 Clock Configuration Modes

To configure the main PLL multiplication factor and the core, CPM, and 60x bus frequencies, the MODCK[1–3] pins are sampled while $\overline{\text{HRESET}}$ is asserted. Table 12 shows the eight basic configuration modes. Another 49 modes are available by using the configuration pin (RSTCONF) and driving four pins on the data bus.

1.3.1 Local Bus Mode

Table 12 describes default clock modes for the MPC8260.

Table 12. Clock Default Modes

MODCK[1–3]	Input Clock Frequency	CPM Multiplication Factor	CPM Frequency	Core Multiplication Factor	Core Frequency
000	33 MHz	3	100 MHz	4	133 MHz
001	33 MHz	3	100 MHz	5	166 MHz
010	33 MHz	4	133 MHz	4	133 MHz
011	33 MHz	4	133 MHz	5	166 MHz
100	66 MHz	2	133 MHz	2.5	166 MHz
101	66 MHz	2	133 MHz	3	200 MHz
110	66 MHz	2.5	166 MHz	2.5	166 MHz
111	66 MHz	2.5	166 MHz	3	200 MHz

Table 13 describes all possible clock configurations when using the hard reset configuration sequence. Note that clock configuration changes only after $\overline{\text{POR}}$ is asserted. Note also that basic modes are shown in boldface type.

Table 13. Clock Configuration Modes¹

MODCK_H–MODCK[1–3]	Input Clock Frequency ^{2,3}	CPM Multiplication Factor ²	CPM Frequency ²	Core Multiplication Factor ²	Core Frequency ²
0001_000	33 MHz	2	66 MHz	4	133 MHz
0001_001	33 MHz	2	66 MHz	5	166 MHz
0001_010	33 MHz	2	66 MHz	6	200 MHz
0001_011	33 MHz	2	66 MHz	7	233 MHz
0001_100	33 MHz	2	66 MHz	8	266 MHz
0001_101	33 MHz	3	100 MHz	4	133 MHz
0001_110	33 MHz	3	100 MHz	5	166 MHz
0001_111	33 MHz	3	100 MHz	6	200 MHz
0010_000	33 MHz	3	100 MHz	7	233 MHz
0010_001	33 MHz	3	100 MHz	8	266 MHz

Clock Configuration Modes

Table 13. Clock Configuration Modes¹ (Continued)

MODCK_H–MODCK[1–3]	Input Clock Frequency ^{2,3}	CPM Multiplication Factor ²	CPM Frequency ²	Core Multiplication Factor ²	Core Frequency ²
0010_010	33 MHz	4	133 MHz	4	133 MHz
0010_011	33 MHz	4	133 MHz	5	166 MHz
0010_100	33 MHz	4	133 MHz	6	200 MHz
0010_101	33 MHz	4	133 MHz	7	233 MHz
0010_110	33 MHz	4	133 MHz	8	266 MHz
0010_111	33 MHz	5	166 MHz	4	133 MHz
0011_000	33 MHz	5	166 MHz	5	166 MHz
0011_001	33 MHz	5	166 MHz	6	200 MHz
0011_010	33 MHz	5	166 MHz	7	233 MHz
0011_011	33 MHz	5	166 MHz	8	266 MHz
0011_100	33 MHz	6	200 MHz	4	133 MHz
0011_101	33 MHz	6	200 MHz	5	166 MHz
0011_110	33 MHz	6	200 MHz	6	200 MHz
0011_111	33 MHz	6	200 MHz	7	233 MHz
0100_000	33 MHz	6	200 MHz	8	266 MHz
0100_001	Reserved				
0100_010					
0100_011					
0100_100					
0100_101					
0100_110					
0100_111	Reserved				
0101_000					
0101_001					
0101_010					
0101_011					
0101_100					
0101_101	66 MHz	2	133 MHz	2	133 MHz
0101_110	66 MHz	2	133 MHz	2.5	166 MHz
0101_111	66 MHz	2	133 MHz	3	200 MHz
0110_000	66 MHz	2	133 MHz	3.5	233 MHz
0110_001	66 MHz	2	133 MHz	4	266 MHz

Table 13. Clock Configuration Modes¹ (Continued)

MODCK_H–MODCK[1–3]	Input Clock Frequency ^{2,3}	CPM Multiplication Factor ²	CPM Frequency ²	Core Multiplication Factor ²	Core Frequency ²
0110_010	66 MHz	2	133 MHz	4.5	300 MHz
0110_011	66 MHz	2.5	166 MHz	2	133 MHz
0110_100	66 MHz	2.5	166 MHz	2.5	166 MHz
0110_101	66 MHz	2.5	166 MHz	3	200 MHz
0110_110	66 MHz	2.5	166 MHz	3.5	233 MHz
0110_111	66 MHz	2.5	166 MHz	4	266 MHz
0111_000	66 MHz	2.5	166 MHz	4.5	300 MHz
0111_001	66 MHz	3	200 MHz	2	133 MHz
0111_010	66 MHz	3	200 MHz	2.5	166 MHz
0111_011	66 MHz	3	200 MHz	3	200 MHz
0111_100	66 MHz	3	200 MHz	3.5	233 MHz
0111_101	66 MHz	3	200 MHz	4	266 MHz
0111_110	66 MHz	3	200 MHz	4.5	300 MHz
0111_111	66 MHz	3.5	233 MHz	2	133 MHz
1000_000	66 MHz	3.5	233 MHz	2.5	166 MHz
1000_001	66 MHz	3.5	233 MHz	3	200 MHz
1000_010	66 MHz	3.5	233 MHz	3.5	233 MHz
1000_011	66 MHz	3.5	233 MHz	4	266 MHz
1000_100	66 MHz	3.5	233 MHz	4.5	300 MHz

¹ Because of speed dependencies, not all of the possible configurations in Table 13 are applicable.

² The user should choose the input clock frequency and the multiplication factors such that the frequency of the CPU ranges between 133–200 and the CPM ranges between 50–166 MHz.

³ Input clock frequency is given only for the purpose of reference. User should set MODCK_H–MODCK_L so that the resulting configuration does not exceed the frequency rating of the user's part.

Example. If a part is rated at 266 MHz CPU, 200 MHz CPM, and 66 MHz bus, any of the following are possible (note that the three input clock frequencies are only three of many possible input clock frequencies):

1. 66 MHz input clock and MODCK_H–MODCK_L[0111–101] (with a core multiplication factor of 4 and a CPM multiplication factor of 3). The resulting configuration equals the part's maximum possible frequencies of 266 MHz CPU, 200 MHz CPM, and 66 MHz bus.
2. 50 MHz input clock and MODCK_H–MODCK_L[0111–101] to achieve a configuration of 200 MHz CPU, 150 MHz CPM, and 50 MHz bus.
3. 40 MHz input clock and MODCK_H–MODCK_L[0010–011] to achieve a configuration of 200 MHz CPU, 160 MHz CPM, and 40 MHz bus.

Note that with each example, any one of several values for MODCK_H–MODCK_L could possibly be used as long as the resulting configuration does not exceed the part's rating.

1.4 Pinout

This section provides the pin assignments and pinout list for the MPC8260.

1.4.1 Pin Assignments

Figure 12 shows the pinout of the MPC8260's 480 TBGA package as viewed from the top surface.

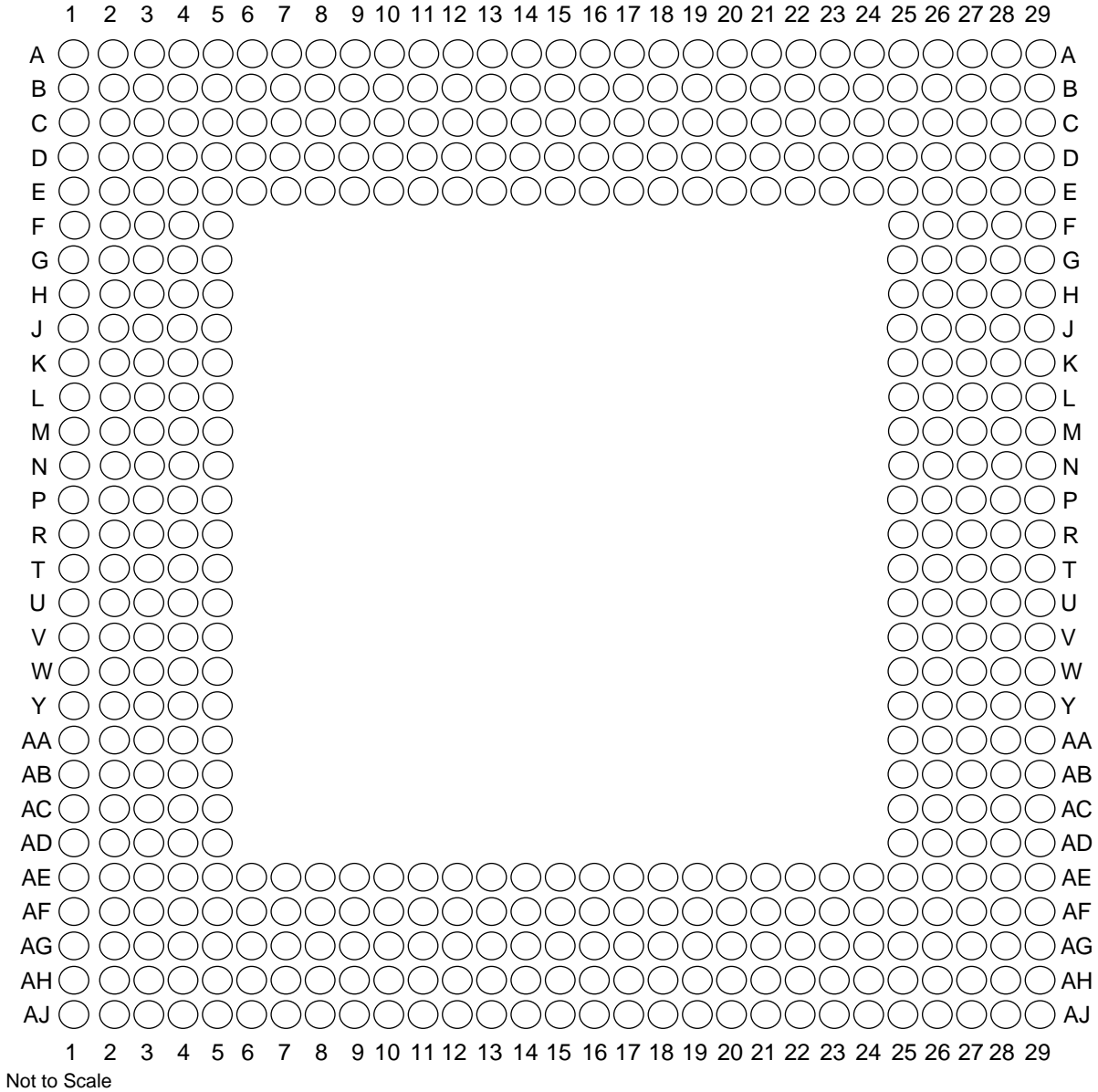

Figure 12. Pinout of the 480 TBGA Package as Viewed from the Top Surface

Figure 13 shows the side profile of the TBGA package to indicate the direction of the top surface view.

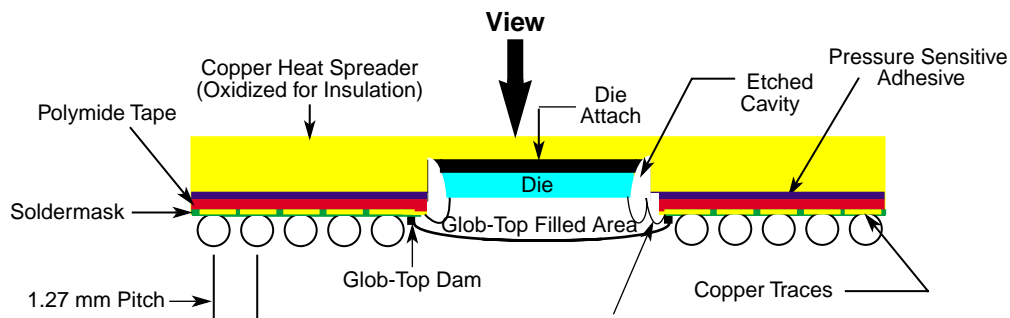

Figure 13. Side View of the TBGA Package

Table 14 shows the pinout list of the MPC8260. Table 15 defines conventions and acronyms used in Table 14.

Table 14. Pinout List

Pin Name	Ball
BR	W5
BG	F4
ABB/IRQ2	E2
TS	E3
A0	G1
A1	H5
A2	H2
A3	H1
A4	J5
A5	J4
A6	J3
A7	J2
A8	J1
A9	K4
A10	K3
A11	K2
A12	K1
A13	L5
A14	L4
A15	L3
A16	L2
A17	L1
A18	M5
A19	N5

Pinout

Table 14. Pinout List (Continued)

Pin Name	Ball
A20	N4
A21	N3
A22	N2
A23	N1
A24	P4
A25	P3
A26	P2
A27	P1
A28	R1
A29	R3
A30	R5
A31	R4
TT0	F1
TT1	G4
TT2	G3
TT3	G2
TT4	F2
TBST	D3
TSIZ0	C1
TSIZ1	E4
TSIZ2	D2
TSIZ3	F5
AACK	F3
ARTRY	E1
DBG	V1
DBB/IRQ3	V2
D0	B20
D1	A18
D2	A16
D3	A13
D4	E12
D5	D9
D6	A6
D7	B5
D8	A20

Table 14. Pinout List (Continued)

Pin Name	Ball
D9	E17
D10	B15
D11	B13
D12	A11
D13	E9
D14	B7
D15	B4
D16	D19
D17	D17
D18	D15
D19	C13
D20	B11
D21	A8
D22	A5
D23	C5
D24	C19
D25	C17
D26	C15
D27	D13
D28	C11
D29	B8
D30	A4
D31	E6
D32	E18
D33	B17
D34	A15
D35	A12
D36	D11
D37	C8
D38	E7
D39	A3
D40	D18
D41	A17
D42	A14
D43	B12

Pinout

Table 14. Pinout List (Continued)

Pin Name	Ball
D44	A10
D45	D8
D46	B6
D47	C4
D48	C18
D49	E16
D50	B14
D51	C12
D52	B10
D53	A7
D54	C6
D55	D5
D56	B18
D57	B16
D58	E14
D59	D12
D60	C10
D61	E8
D62	D6
D63	C2
DP0/RSRV/EXT_BR2	B22
IRQ1/DP1/EXT_BG2	A22
IRQ2/DP2/TLBISYNC/EXT_DBG2	E21
IRQ3/DP3/CKSTP_OUT/EXT_BR3	D21
IRQ4/DP4/CORE_SRESET/EXT_BG3	C21
IRQ5/DP5/TBEN/EXT_DBG3	B21
IRQ6/DP6/CSE0	A21
IRQ7/DP7/CSE1	E20
PSDVAL	V3
TA	C22
TEA	V5
GBL/IRQ1	W1
C \bar{I} /BADDR29/IRQ2	U2
WT/BADDR30/IRQ3	U3
L2_HIT/IRQ4	Y4

Table 14. Pinout List (Continued)

Pin Name	Ball
CPU_BG/BADDR31/IRQ5	U4
CPU_DBG	R2
CPU_BR	Y3
CS0	F25
CS1	C29
CS2	E27
CS3	E28
CS4	F26
CS5	F27
CS6	F28
CS7	G25
CS8	D29
CS9	E29
CS10/BCTL1	F29
CS11/AP0	G28
BADDR27	T5
BADDR28	U1
ALE	T2
BCTL0	A27
PWE0/PSDDQM0/PBS0	C25
PWE1/PSDDQM1/PBS1	E24
PWE2/PSDDQM2/PBS2	D24
PWE3/PSDDQM3/PBS3	C24
PWE4/PSDDQM4/PBS4	B26
PWE5/PSDDQM5/PBS5	A26
PWE6/PSDDQM6/PBS6	B25
PWE7/PSDDQM7/PBS7	A25
PSDA10/PGPL0	E23
PSDWE/PGPL1	B24
POE/PSDRAS/PGPL2	A24
PSDCAS/PGPL3	B23
PGTA/PUPMWAIT/PGPL4/PPBS	A23
PSDAMUX/PGPL5	D22
LWE0/LSDDQM0/LBS0/	H28
LWE1/LSDDQM1/LBS1/	H27

Pinout

Table 14. Pinout List (Continued)

Pin Name	Ball
LWE2/LSDDQM2/LBS2/	H26
LWE3/LSDDQM3/LBS3/	G29
LSDA10/LGPL0/	D27
LSDWE/LGPL1/	C28
LOE/LSDRAS/LGPL2/	E26
LSDCAS/LGPL3/	D25
LGTA/LUPMWAIT/LGPL4/LPBS	C26
LGPL5/LSDAMUX ¹	B27
LWR	D28
L_A14	N27
L_A15/SM \bar{I}	T29
L_A16	R27
L_A17/CKSTP_OUT	R26
L_A18	R29
L_A19	R28
L_A20	W29
L_A21	P28
L_A22	N26
L_A23	AA27
L_A24	P29
L_A25	AA26
L_A26	N25
L_A27	AA25
L_A28/CORE_SRESET	AB29
L_A29	AB28
L_A30	P25
L_A31	AB27
LCL_D0	H29
LCL_D1	J29
LCL_D2	J28
LCL_D3	J27
LCL_D4	J26
LCL_D5	J25
LCL_D6	K25
LCL_D7	L29

Table 14. Pinout List (Continued)

Pin Name	Ball
LCL_D8	L27
LCL_D9	L26
LCL_D10	L25
LCL_D11	M29
LCL_D12	M28
LCL_D13	M27
LCL_D14	M26
LCL_D15	N29
LCL_D16	T25
LCL_D17	U27
LCL_D18	U26
LCL_D19	U25
LCL_D20	V29
LCL_D21	V28
LCL_D22	V27
LCL_D23	V26
LCL_D24	W27
LCL_D25	W26
LCL_D26	W25
LCL_D27	Y29
LCL_D28	Y28
LCL_D29	Y25
LCL_D30	AA29
LCL_D31	AA28
LCL_DP0	L28
LCL_DP1	N28
LCL_DP2	T28
LCL_DP3	W28
IRQ0/NMI_OUT	T1
IRQ7/INT_OUT/APE	D1
TRST	AH3
TCK	AG5
TMS	AJ3
TDI	AE6
TDO	AF5

Pinout

Table 14. Pinout List (Continued)

Pin Name	Ball
TRIS	AB4
PORESET	AG6
HRESET	AH5
SRESET	AF6
QREQ	AA3
RSTCONF	AJ4
MODCK1/AP1/TC0/BNKSEL0	W2
MODCK2/AP2/TC1/BNKSEL1	W3
MODCK3/AP3/TC2/BNKSEL2	W4
XFC	AB2
CLKIN1	AH4
PA0/RESTART1/DREQ3/FCC2_UTM_TXADDR2	AC29
PA1/REJECT1/FCC2_UTM_TXADDR1/DONE3	AC25
PA2/CLK20/FCC2_UTM_TXADDR0/DACK3	AE28
PA3/CLK19/FCC2_UTM_RXADDR0/DACK4/L1RXD1A2	AG29
PA4/REJECT2/FCC2_UTM_RXADDR1/DONE4	AG28
PA5/RESTART2/DREQ4/FCC2_UTM_RXADDR2	AG26
PA6/L1RSYNCA1	AE24
PA7/SMSYN2/L1TSYNCA1/L1GN1A1	AH25
PA8/SMRXD2/L1RXD0A1/L1RXDA1	AF23
PA9/SMTXD2/L1TXD0A1	AH23
PA10/FCC1_UT8_RXD0/FCC1_UT16_RXD8/MSNUM5	AE22
PA11/FCC1_UT8_RXD1/FCC1_UT16_RXD9/MSNUM4	AH22
PA12/FCC1_UT8_RXD2/FCC1_UT16_RXD10/MSNUM3	AJ21
PA13/FCC1_UT8_RXD3/FCC1_UT16_RXD11/MSNUM2	AH20
PA14/FCC1_UT8_RXD4/FCC1_UT16_RXD12/FCC1_RXD3	AG19
PA15/FCC1_UT8_RXD5/FCC1_UT16_RXD13/FCC1_RXD2	AF18
PA16/FCC1_UT8_RXD6/FCC1_UT16_RXD14/FCC1_RXD1	AF17
PA17/FCC1_UT8_RXD7/FCC1_UT16_RXD15/FCC1_RXD0/FCC1_RXD	AE16
PA18/FCC1_UT8_TXD7/FCC1_UT16_TXD15/FCC1_TXD0/FCC1_TXD	AJ16
PA19/FCC1_UT8_TXD6/FCC1_UT16_TXD14/FCC1_TXD1	AG15
PA20/FCC1_UT8_TXD5/FCC1_UT16_TXD13/FCC1_TXD2	AJ13
PA21/FCC1_UT8_TXD4/FCC1_UT16_TXD12/FCC1_TXD3	AE13
PA22/FCC1_UT8_TXD3/FCC1_UT16_TXD11	AF12
PA23/FCC1_UT8_TXD2/FCC1_UT16_TXD10	AG11

Table 14. Pinout List (Continued)

Pin Name	Ball
PA24/FCC1_UT8_TXD1/FCC1_UT16_TXD9/MSNUM1	AH9
PA25/FCC1_UT8_TXD0/FCC1_UT16_TXD8/MSNUM0	AJ8
PA26/FCC1_UTM_RXCLAV/FCC1_UTS_RXCLAV/FCC1_MII_RX_ER	AH7
PA27/FCC1_UT_RXSOC/FCC1_MII_RX_DV	AF7
PA28/FCC1_UTM_RXENB/FCC1_UTS_RXENB/FCC1_MII_TX_EN	AD5
PA29/FCC1_UT_TXSOC/FCC1_MII_TX_ER	AF1
PA30/FCC1_UTM_TXCLAV/FCC1_UTS_TXCLAV/FCC1_MII_CRS/FCC1_RTS	AD3
PA31/FCC1_UTM_TXENB/FCC1_UTS_TXENB/FCC1_MII_COL	AB5
PB4/FCC3_TXD3/FCC2_UT8_RXD0/L1RSYNCA2/FCC3_RTS	AD28
PB5/FCC3_TXD2/FCC2_UT8_RXD1/L1TSYNCA2/L1GNTA2	AD26
PB6/FCC3_TXD1/FCC2_UT8_RXD2/L1RXDA2/L1RXD0A2	AD25
PB7/FCC3_TXD0/FCC3_TXD/FCC2_UT8_RXD3/L1TXDA2/L1TXD0A2	AE26
PB8/FCC2_UT8_TXD3/FCC3_RXD0/FCC3_RXD/TXD3/L1RSYNCD1	AH27
PB9/FCC2_UT8_TXD2/FCC3_RXD1/L1TXD2A2/L1TSYNCD1/L1GNTD1	AG24
PB10/FCC2_UT8_TXD1/FCC3_RXD2/L1RXDD1	AH24
PB11/FCC3_RXD3/FCC2_UT8_TXD0/L1TXDD1	AJ24
PB12/FCC3_MII_CRS/L1CLKOB1/L1RSYNCC1/TXD2	AG22
PB13/FCC3_MII_COL/L1RQB1/L1TSYNCC1/L1GNTC1/L1TXD1A2	AH21
PB14/FCC3_MII_TX_EN/RXD3/L1RXDC1	AG20
PB15/FCC3_MII_TX_ER/RXD2/L1TXDC1	AF19
PB16/FCC3_MII_RX_ER/L1CLKOA1/CLK18	AJ18
PB17/FCC3_MII_RX_DV/L1RQA1/CLK17	AJ17
PB18/FCC2_UT8_RXD4/FCC2_RXD3/L1CLKOD2/L1RXD2A2	AE14
PB19/FCC2_UT8_RXD5/FCC2_RXD2/L1RQD2/L1RXD3A2	AF13
PB20/FCC2_UT8_RXD6/FCC2_RXD1/L1RSYNCD2/L1TXD1A1	AG12
PB21/FCC2_UT8_RXD7/FCC2_RXD0/FCC2_RXD/L1TSYNCD2/L1GNTD2/ L1TXD2A1	AH11
PB22/FCC2_UT8_TXD7/FCC2_TXD0/FCC2_TXD/L1RXD1A1/L1RXDD2	AH16
PB23/FCC2_UT8_TXD6/FCC2_TXD1/L1RXD2A1/L1TXDD2	AE15
PB24/FCC2_UT8_TXD5/FCC2_TXD2/L1RXD3A1/L1RSYNCC2	AJ9
PB25/FCC2_UT8_TXD4/FCC2_TXD3/L1TSYNCC2/L1GNTC2/L1TXD3A1	AE9
PB26/FCC2_MII_CRS/FCC2_UT8_TXD1/L1RXDC2	AJ7
PB27/FCC2_MII_COL/FCC2_UT8_TXD0/L1TXDC2	AH6
PB28/FCC2_MII_RX_ER/FCC2_RTS/L1TSYNCB2/L1GNTB2/TXD1	AE3
PB29/FCC2_UTM_RXCLAV/FCC2_UTS_RXCLAV/L1RSYNCB2/ FCC2_MII_TX_EN	AE2

Pinout

Table 14. Pinout List (Continued)

Pin Name	Ball
PB30/FCC2_MII_RX_DV/FCC2_UT_TXSOC/L1RXDB2	AC5
PB31/FCC2_MII_TX_ER/FCC2_UT_RXSOC/L1TXDB2	AC4
PC0/DREQ1/BRGO7/SMSYN2/L1CLKOA2	AB26
PC1/DREQ2/BRGO6/L1RQA2	AD29
PC2/FCC3_CD/FCC2_UT8_TXD3/DONE2	AE29
PC3/FCC3_CTS/FCC2_UT8_TXD2/DACK2/CTS4	AE27
PC4/FCC2_UTM_RXENB/FCC2_UTS_RXENB/SI2_L1ST4/FCC2_CD	AF27
PC5/FCC2_UTM_TXCLAV/FCC2_UTS_TXCLAV/SI2_L1ST3/FCC2_CTS	AF24
PC6/FCC1_CD/L1CLKOC1/FCC1_UTM_RXADDR2/FCC1_UTS_RXADDR2/ FCC1_UTM_RXCLAV1	AJ26
PC7/FCC1_CTS/L1RQC1/FCC1_UTM_TXADDR2/FCC1_UTS_TXADDR2/ FCC1_UTM_TXCLAV1	AJ25
PC8/CD4/RENA4/FCC1_UT16_TXD0/SI2_L1ST2/CTS3	AF22
PC9/CTS4/CLSN4/FCC1_UT16_TXD1/SI2_L1ST1/L1TSYNCA2/L1GNTA2	AE21
PC10/CD3/RENA3/FCC1_UT16_TXD2/SI1_L1ST4/FCC2_UT8_RXD3	AF20
PC11/CTS3/CLSN3/L1CLKOD1/L1TXD3A2/FCC2_UT8_RXD2	AE19
PC12/CD2/RENA2/SI1_L1ST3/FCC1_UTM_RXADDR1/FCC1_UTS_RXADDR1	AE18
PC13/CTS2/CLSN2/L1RQD1/FCC1_UTM_TXADDR1/FCC1_UTS_TXADDR1	AH18
PC14/CD1/RENA1/FCC1_UTM_RXADDR0/FCC1_UTS_RXADDR0	AH17
PC15/CTS1/CLSN1/SMTXD2/FCC1_UTM_TXADDR0/FCC1_UTS_TXADDR0	AG16
PC16/CLK16/TIN4	AF15
PC17/CLK15/TIN3/BRGO8	AJ15
PC18/CLK14/TGATE2	AH14
PC19/CLK13/BRGO7	AG13
PC20/CLK12/TGATE1	AH12
PC21/CLK11/BRGO6	AJ11
PC22/CLK10/DONE1	AG10
PC23/CLK9/BRGO5/DACK1	AE10
PC24/FCC2_UT8_TXD3/CLK8/TOUT4	AF9
PC25/FCC2_UT8_TXD2/CLK7/BRGO4	AE8
PC26/CLK6/TOUT3/TMCLK	AJ6
PC27/FCC3_TXD/FCC3_TXD0/CLK5/BRGO3	AG2
PC28/CLK4/TIN1/TOUT2/CTS2/CLSN2	AF3
PC29/CLK3/TIN2/BRGO2/CTS1/CLSN1	AF2
PC30/FCC2_UT8_TXD3/CLK2/TOUT1	AE1
PC31/CLK1/BRGO1	AD1

Table 14. Pinout List (Continued)

Pin Name	Ball
PD4/BRGO8/L1TSYNCD1/L1GNTD1/FCC3_RTS/SMRXD2	AC28
PD5/FCC1_UT16_TXD3/DONE1	AD27
PD6/FCC1_UT16_TXD4/DACK1	AF29
PD7/SMSYN1/FCC1_UTM_TXADDR3/FCC1_UTS_TXADDR3/FCC1_TXCLAV2	AF28
PD8/SMRXD1/FCC2_UT_TXPRTY/BRGO5	AG25
PD9/SMTXD1/FCC2_UT_RXPRTY/BRGO3	AH26
PD10/L1CLKOB2/FCC2_UT8_RXD1/L1RSYNCB1/BRGO4	AJ27
PD11/L1RQB2/FCC2_UT8_RXD0/L1TSYNCB1/L1GNTB1	AJ23
PD12/SI1_L1ST2/L1RXDB1	AG23
PD13/SI1_L1ST1/L1TXDB1	AJ22
PD14/FCC1_UT16_RXD0/L1CLKOC2/I2CSCL	AE20
PD15/FCC1_UT16_RXD1/L1RQC2/I2CSDA	AJ20
PD16/FCC1_UT_TXPRTY/L1TSYNCC1/L1GNTC1/SPIMISO	AG18
PD17/FCC1_UT_RXPRTY/BRGO2/SPIMOSI	AG17
PD18/FCC1_UTM_RXADDR4/FCC1_UTS_RXADDR4/FCC1_UTM_RXCLAV3/S PICK	AF16
PD19/FCC1_UTM_TXADDR4/FCC1_UTS_TXADDR4/FCC1_UTM_TXCLAV3/S PISEL/BRGO1	AH15
PD20/RTS4/TENA4/FCC1_UT16_RXD2/L1RSYNCA2	AJ14
PD21/TXD4/FCC1_UT16_RXD3/L1RXD0A2/L1RXDA2	AH13
PD22/RXD4/FCC1_UT16_TXD5/L1TXD0A2/L1TXDA2	AJ12
PD23/RTS3/TENA3/FCC1_UT16_RXD4/L1RSYNCD1	AE12
PD24/TXD3/FCC1_UT16_RXD5/L1RXDD1	AF10
PD25/RXD3/FCC1_UT16_TXD6/L1TXDD1	AG9
PD26/RTS2/TENA2/FCC1_UT16_RXD6/L1RSYNCC1	AH8
PD27/TXD2/FCC1_UT16_RXD7/L1RXDC1	AG7
PD28/RXD2/FCC1_UT16_TXD7/L1TXDC1	AE4
PD29/RTS1/TENA1/FCC1_UTM_RXADDR3/FCC1_UTS_RXADDR3/ FCC1_UTM_RXCLAV2	AG1
PD30/FCC2_UTM_TXENB/FCC2_UTS_TXENB/TXD1	AD4
PD31/RXD1	AD2
VCCSYN	AB3
VCCSYN1	B9
GND SYN	AB1
SPARE1 ²	AE11
SPARE4 ²	U5
SPARE5 ³	AF25

Pinout

Table 14. Pinout List (Continued)

Pin Name	Ball
SPARE6 ²	V4
THERMAL0 ⁴	AA1
THERMAL1 ⁴	AG4
I/O power	AG21, AG14, AG8, AJ1, AJ2, AH1, AH2, AG3, AF4, AE5, AC27, Y27, T27, P27, K26, G27, AE25, AF26, AG27, AH28, AH29, AJ28, AJ29, C7, C14, C16, C20, C23, E10, A28, A29, B28, B29, C27, D26, E25, H3, M4, T3, AA4, A1, A2, B1, B2, C3, D4, E5
Core Power	U28, U29, K28, K29, A9, A19, B19, M1, M2, Y1, Y2, AC1, AC2, AH19, AJ19, AH10, AJ10, AJ5
Ground	AA5, AF21, AF14, AF8, AE7, AF11, AE17, AE23, AC26, AB25, Y26, V25, T26, R25, P26, M25, K27, H25, G26, D7, D10, D14, D16, D20, D23, C9, E11, E13, E15, E19, E22, B3, G5, H4, K5, M3, P5, T4, Y5, AA2, AC3

¹ Only on Rev C.2 silicon.

² Must be pulled down or left floating.

³ Must be pulled down or left floating. However, if compatibility with HiP4 silicon is required, this pin must be pulled up or left floating.

⁴ For information on how to use this pin, refer to MPC8260 PowerQUICC II Thermal Resistor Guide available at www.motorola.com/semiconductors.

Symbols used in Table 14 are described in Table 15.

Table 15. Symbol Legend

Symbol	Meaning
OVERBAR	Signals with overbars, such as \overline{TA} , are active low.
UTM	Indicates that a signal is part of the UTOPIA master interface.
UTS	Indicates that a signal is part of the UTOPIA slave interface.
UT8	Indicates that a signal is part of the 8-bit UTOPIA interface.
UT16	Indicates that a signal is part of the 16-bit UTOPIA interface.
MII	Indicates that a signal is part of the media independent interface.

1.5 Package Description

The following sections provide the package parameters and mechanical dimensions for the MPC8260.

1.5.1 Package Parameters

Package parameters are provided in Table 16. The package type is a 37.5 x 37.5 mm, 480-lead TBGA.

Table 16. Package Parameters

Parameter	Value
Package Outline	37.5 x 37.5 mm
Interconnects	480 (29 x 29 ball array)
Pitch	1.27 mm
Nominal unmounted package height	1.55 mm

1.5.2 Mechanical Dimensions

Figure 14 provides the mechanical dimensions and bottom surface nomenclature of the 480 TBGA package.

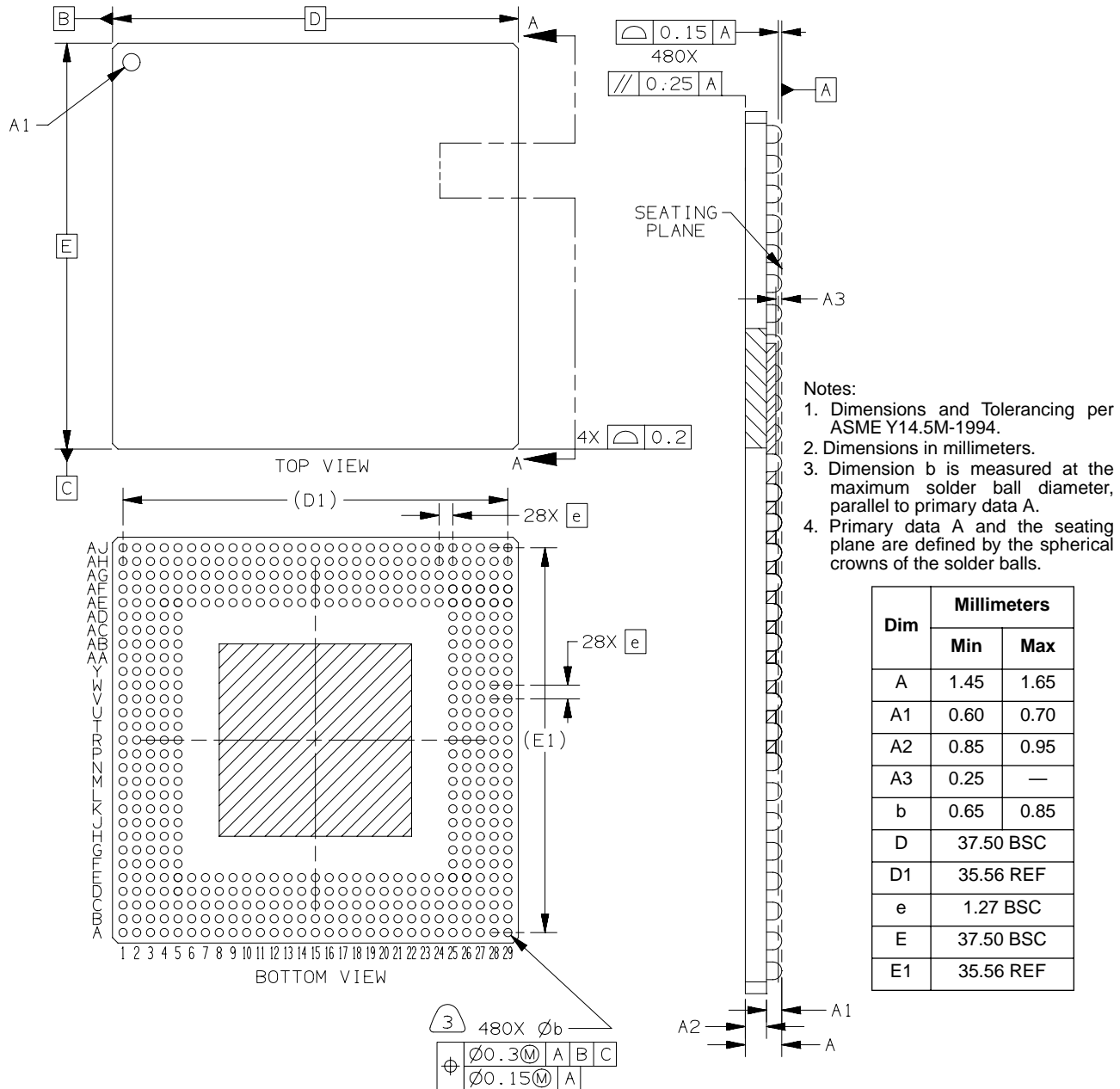

Figure 14. Mechanical Dimensions and Bottom Surface Nomenclature

1.6 Ordering Information

Figure 15 provides an example of the Motorola part numbering nomenclature for the MPC8260. In addition to the processor frequency, the part numbering scheme also consists of a part modifier that indicates any enhancement(s) in the part from the original production design. Each part number also contains a revision code that refers to the die mask revision number and is specified in the part numbering scheme for identification purposes only. For more information, contact your local Motorola sales office.

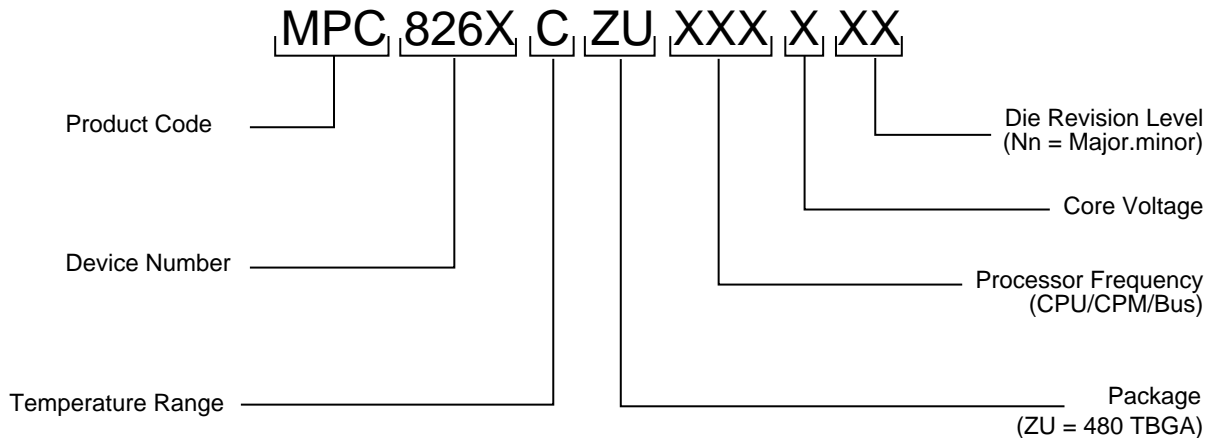

Figure 15. Motorola Part Number Key

1.7 Document Revision History

Table 17 lists significant changes in each revision of this document.

Table 17. Document Revision History

Document Revision	Substantive Changes
0	Initial version
0.1	—
0.2–0.5	Temporary revisions
0.6	Corrected the thermal values in Table 3, “Thermal Characteristics.”
0.7	<ul style="list-style-type: none"> Revision of Table 5, “Power Dissipation” Modifications to Figure 8, Table 2, Table 10, Table 11 Additional revisions to text and figures throughout
0.8	<ul style="list-style-type: none"> Table 7, Table 8, Table 9, and Table 10: revision 0.7 of this document incorrectly included values for 83 MHz. 83 MHz is not supported on the MPC8260. Table 14: notes added to pins at AE11, AF25, U5, and V4.
0.9	<ul style="list-style-type: none"> Table 14: additional note added to AE11
1.0	<ul style="list-style-type: none"> Table 14: modified notes to pins AE11 and AF25. Table 14: added note to pins AA1 and AG4 (Therm0 and Therm1).
1.1	<ul style="list-style-type: none"> Section 1.1, “Features”: updated minimum supported core frequency to 133 MHz Addition of “Note” at bottom of page 5. Table 13: Note 3.

HOW TO REACH US:**USA/EUROPE/LOCATIONS NOT LISTED:**

Motorola Literature Distribution;
P.O. Box 5405, Denver, Colorado 80217
1-303-675-2140 or 1-800-441-2447

JAPAN:

Motorola Japan Ltd.; SPS, Technical Information Center,
3-20-1, Minami-Azabu Minato-ku, Tokyo 106-8573 Japan
81-3-3440-3569

ASIA/PACIFIC:

Motorola Semiconductors H.K. Ltd.; Silicon Harbour
Centre, 2 Dai King Street, Tai Po Industrial Estate,
Tai Po, N.T., Hong Kong
852-26668334

TECHNICAL INFORMATION CENTER:

1-800-521-6274

HOME PAGE:

<http://www.motorola.com/semiconductors>

DOCUMENT COMMENTS:

FAX (512) 933-2625,
Attn: RISC Applications Engineering

Information in this document is provided solely to enable system and software implementers to use Motorola products. There are no express or implied copyright licenses granted hereunder to design or fabricate any integrated circuits or integrated circuits based on the information in this document.

Motorola reserves the right to make changes without further notice to any products herein. Motorola makes no warranty, representation or guarantee regarding the suitability of its products for any particular purpose, nor does Motorola assume any liability arising out of the application or use of any product or circuit, and specifically disclaims any and all liability, including without limitation consequential or incidental damages. "Typical" parameters which may be provided in Motorola data sheets and/or specifications can and do vary in different applications and actual performance may vary over time. All operating parameters, including "Typicals" must be validated for each customer application by customer's technical experts. Motorola does not convey any license under its patent rights nor the rights of others. Motorola products are not designed, intended, or authorized for use as components in systems intended for surgical implant into the body, or other applications intended to support or sustain life, or for any other application in which the failure of the Motorola product could create a situation where personal injury or death may occur. Should Buyer purchase or use Motorola products for any such unintended or unauthorized application, Buyer shall indemnify and hold Motorola and its officers, employees, subsidiaries, affiliates, and distributors harmless against all claims, costs, damages, and expenses, and reasonable attorney fees arising out of, directly or indirectly, any claim of personal injury or death associated with such unintended or unauthorized use, even if such claim alleges that Motorola was negligent regarding the design or manufacture of the part.



Motorola and the Stylized M Logo are registered in the U.S. Patent and Trademark Office. digital dna is a trademark of Motorola, Inc. All other product or service names are the property of their respective owners. Motorola, Inc. is an Equal Opportunity/Affirmative Action Employer.

© Motorola, Inc. 2002

MPC8260EC/D