

Dual Operational Amplifier

Features

- Power Supply Range:
 - Signal Supply : 3V to 20V
 - Dual Supply : $\pm 1.5V$ to $\pm 10V$
- Large DC Voltage Gain : 100dB
- Large Output Swing : $0V \sim V_{DD} - 1.5V$
- Bandwidth(unity gain) : 2MHz
- Internally Frequency Compensated for Unity Gain
- Low Input Offset Voltage : 1mV

General Description

The APA4558 consists of two independent , high gain , internally frequency compensated operational amplifiers which were designed specifically to operate from a single power supply up to 20 volts . Operation from dual power supplies is also possible and the power supply current drain is essentially independent of the magnitude of the power supply voltage .

Application areas include transducer amplifiers , DC gain blocks and all the conventional OP amplifier circuits which can be more easily implemented in single power supply systems . (For example , the APA4558 can be directly operated from the standard +5V power supply voltage which is normally used in digital systems .)

Applications

- Amplifiers
- Filters
- Analog Circuit

Ordering Information

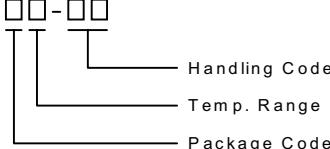
<p>APA4558 □□-□□</p> 	<p>Package Code J : PDIP K : SOP-8 O : TSSOP-8 Temp. Range C : 0 to 70 °C Handling Code TU : Tube TR : Tape & Reel</p>
---	--

Block Diagram

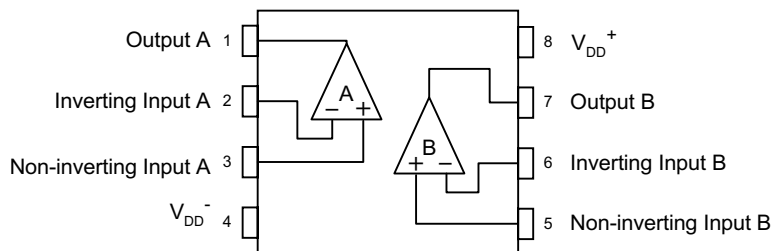

ANPEC reserves the right to make changes to improve reliability or manufacturability without notice, and advise customers to obtain the latest version of relevant information to verify before placing orders.

Absolute Maximum Ratings $T_A = 25^\circ\text{C}$

Symbol	Parameter	Rating	Unit
V_{DD}	Supply Voltage	20	V
V_{ID}	Differential Input Voltage	20	V
V_I	Input Voltage	-0.3V to +20V	V
P_D	Power Dissipation	500	mW
T_A	Operating Free-air Temperature Range	0 to 70	$^\circ\text{C}$
T_{STG}	Storage Temperature Range	-40 to +150	$^\circ\text{C}$

Electrical Characteristics $V_{DD} = \pm 10\text{V}$, $T_A = 25^\circ\text{C}$

Symbol	Parameter	Test Conditions	APA4558			Unit
			Min.	Typ.	Max.	
V_{IO}	Input Offset Voltage	$R_S \leq 10\text{k}\Omega$		1	6	mV
I_{IO}	Input Offset Current			5	200	nA
I_{BIAS}	Input Bias Current			25	500	nA
R_{IN}	Input Resistance		0.3	5		$\text{M}\Omega$
A_V	Large Signal Voltage Gain	$R_L \geq 2\text{k}\Omega$, $V_O = \pm 10\text{V}$	86	100		dB
V_{OM1}	Maximum Output Voltage Swing 1	$R_L \geq 10\text{k}\Omega$	± 9	± 9.5		V
V_{OM2}	Maximum Output Voltage Swing 2	$R_L \geq 2\text{k}\Omega$	± 8.5	± 9.0		V
V_{ICM}	Input Common-Mode Voltage Range		± 9	± 9.5		V
CMRR	Common-Mode Rejection Ratio	$R_S \leq 10\text{k}\Omega$		90		dB
SVRR	Supply Voltage Rejection Ratio	$R_S \leq 10\text{k}\Omega$, $V_{p-p} = 100\text{mV}$, $f_{IN} = 100\text{HZ}$	60	65		dB
I_{CC}	Operating Current			3.7	6	mA
V_{NI}	Equivalent Input Noise Voltage	RIAA, $R_S = 1\text{k}\Omega$, 30kHz, LPF		1.4		μVrms
SR	Slew Rate			650		$\text{mV}/\mu\text{s}$
GBWP	Gain Bandwidth Product			2		MHz

Typical Characteristics

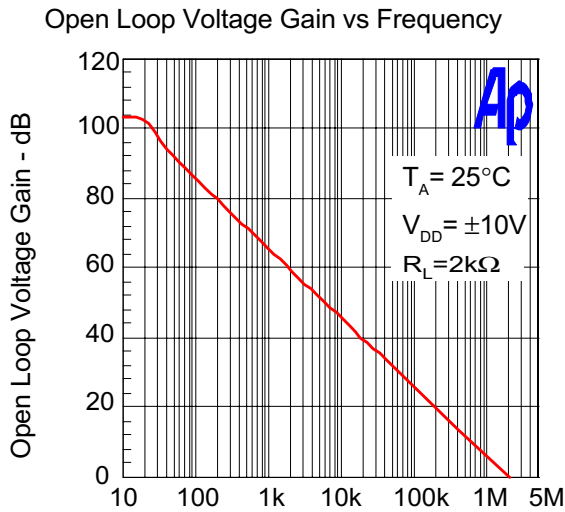

Figure 1 : Frequency (Hz)

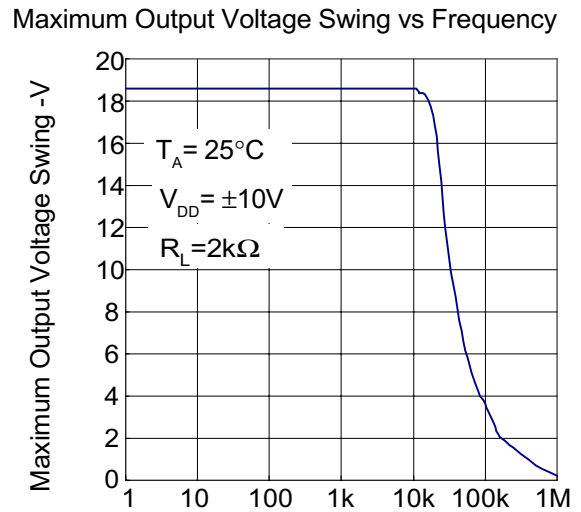

Figure 2 : Frequency (Hz)

Maximum Output Voltage Swing vs Load Resistance

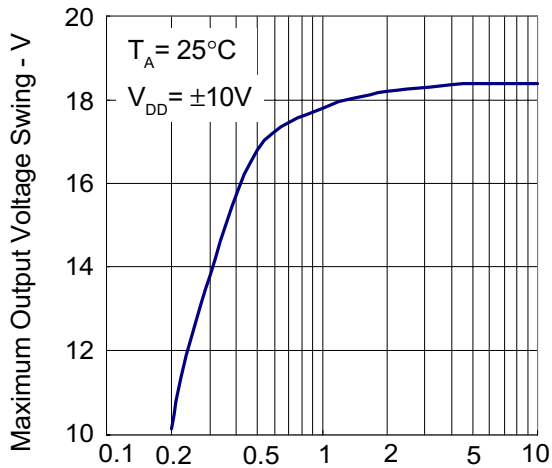

Figure 3 : Load Resistance - $\text{k}\Omega$

Operating Current vs Temperature

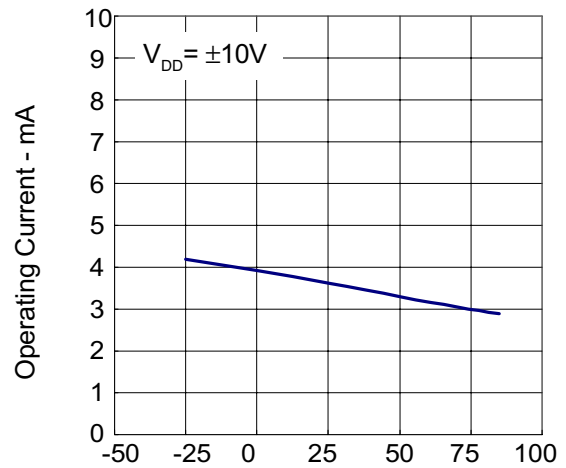

Figure 4 : Temperature - $^\circ\text{C}$

Typical Characteristics Cont.

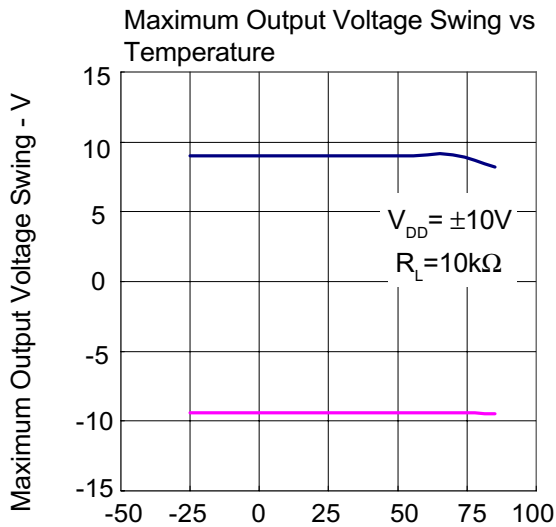

Figure 5 : Temperature - °C

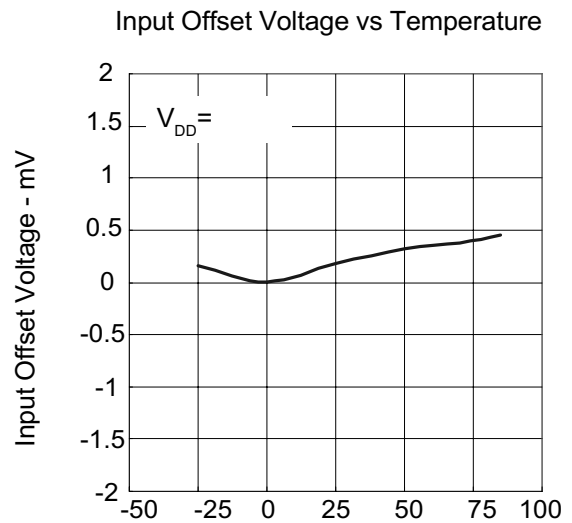

Figure 6 : Temperature - °C

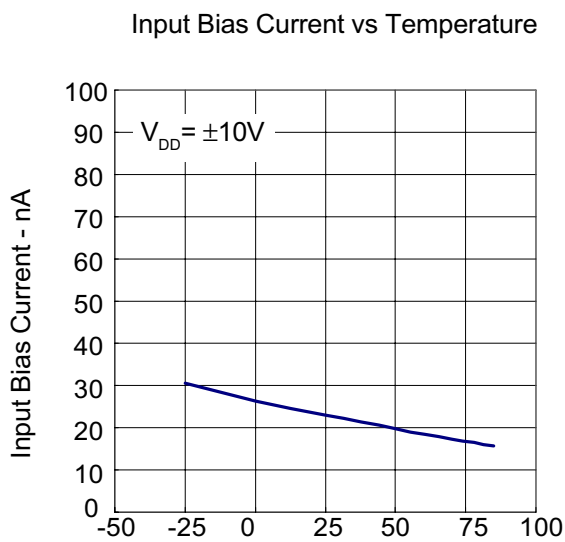

Figure 7 : Temperature - °C

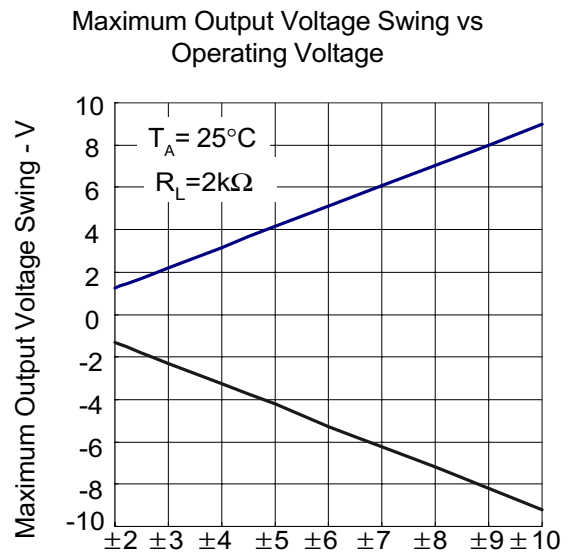

Figure 8 : Operating Voltage - V

Typical Characteristics Cont.

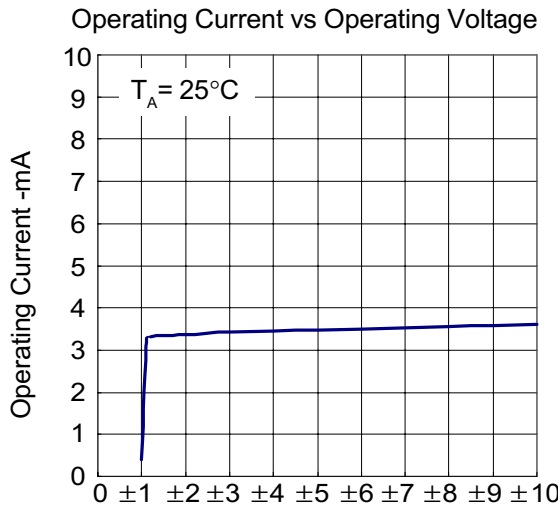

Figure 8 : Operating Voltage - V

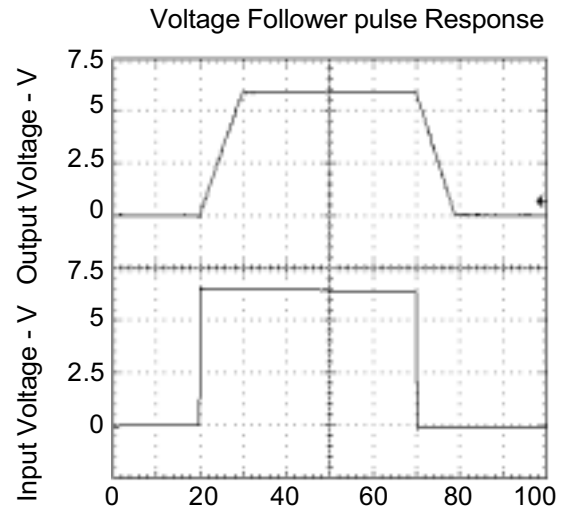

Figure 9 : Time - μs

Customer Service

Anpec Electronics Corp.

Head Office :

5F, No. 2 Li-Hsin Road, SBIP,

Hsin-Chu, Taiwan, R.O.C.

Tel : 886-3-5642000

Fax : 886-3-5642050

Taipei Branch :

7F, No. 137, Lane 235, Pac Chiao Rd.,

Hsin Tien City, Taipei Hsien, Taiwan, R. O. C.

Tel : 886-2-89191368

Fax : 886-2-89191369

Packaging Information

PDIP-8 pin (Reference JEDEC Registration MS-001)

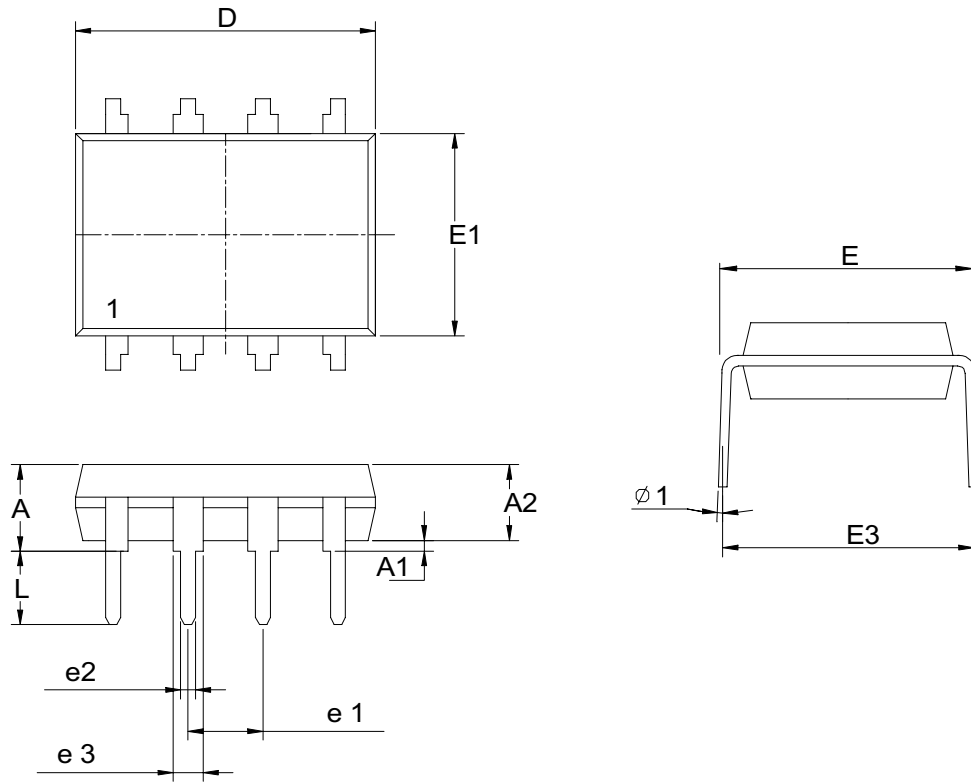

Dim	Millimeters		Inches	
	Min.	Max.	Min.	Max.
A		5.33		0.210
A1	0.38		0.015	
A2	2.92	3.68	0.115	0.145
D	9.02	10.16	0.355	0.400
e1	2.54BSC		0.100BSC	
e2	0.36	0.56	0.014	0.022
e3	1.14	1.78	0.045	0.070
E	7.62 BSC		0.300 BSC	
E1	6.10	7.11	0.240	0.280
E3		10.92		0.430
L	2.92	3.81	0.115	0.150
φ 1	0°	15°	0°	15°

Package Information

SOP- 8 pin (Reference JEDEC Registration MS-012)

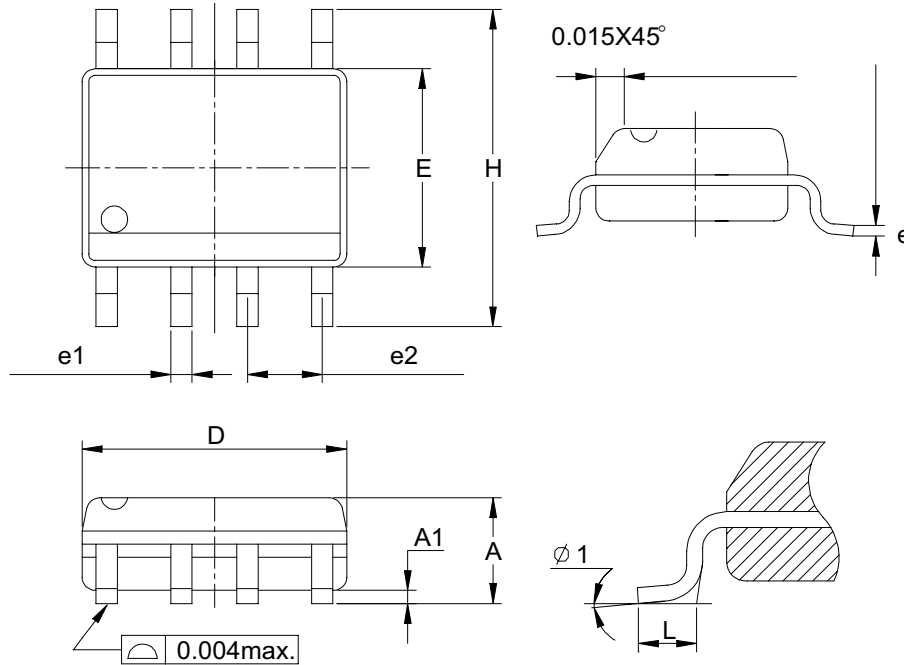

Dim	Millimeters		Inches	
	Min.	Max.	Min.	Max.
A	1.35	1.75	0.053	0.069
A1	0.10	0.25	0.004	0.010
D	4.80	5.00	0.189	0.197
E	3.80	4.00	0.150	0.157
H	5.80	6.20	0.228	0.244
L	0.40	1.27	0.016	0.050
e1	0.33	0.51	0.013	0.020
e2	1.27BSC		0.50BSC	
φ 1	8°		8°	

TSSOP

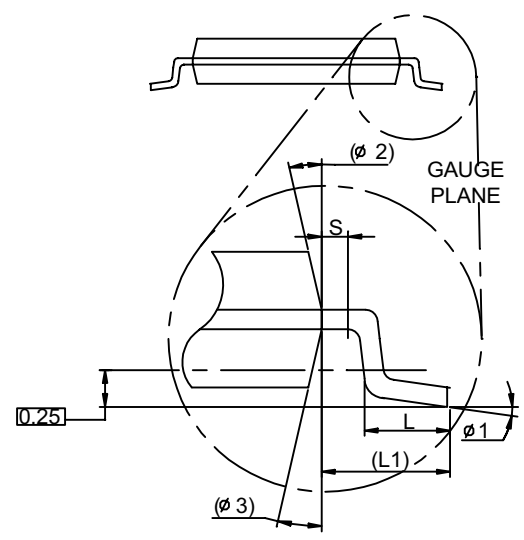
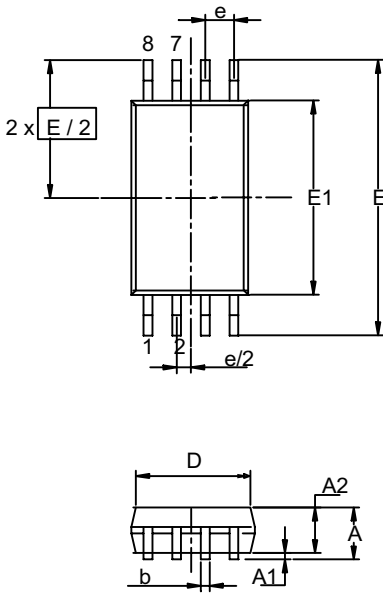

Dim	Millimeters		Inches	
	Min.	Max.	Min.	Max.
A		1.2		0.047
A1	0.00	0.15	0.000	0.006
A2	0.80	1.05	0.031	0.041
b	0.19	0.30	0.007	0.012
D	2.9	3.1	0.114	0.122
e	0.65 BSC		0.026 BSC	
E	6.40 BSC		0.252 BSC	
E1	4.30	4.50	0.169	0.177
L	0.45	0.75	0.018	0.030
L1	1.0 REF		0.039 REF	
R	0.09		0.004	
R1	0.09		0.004	
S	0.2		0.008	
$\phi 1$	0°	8°	0°	8°
$\phi 2$	12° REF		12° REF	
$\phi 3$	12° REF		12° REF	

Physical Specifications

Terminal Material	Solder-Plated Copper (Solder Material : 90/10 or 63/37 SnPb)
Lead Solderability	Meets EIA Specification RSI86-91, ANSI/J-STD-002 Category 3.
Packaging	2500 devices per reel

Reflow Condition (IR/Convection or VPR Reflow)

Reference JEDEC Standard J-STD-020A APRIL 1999

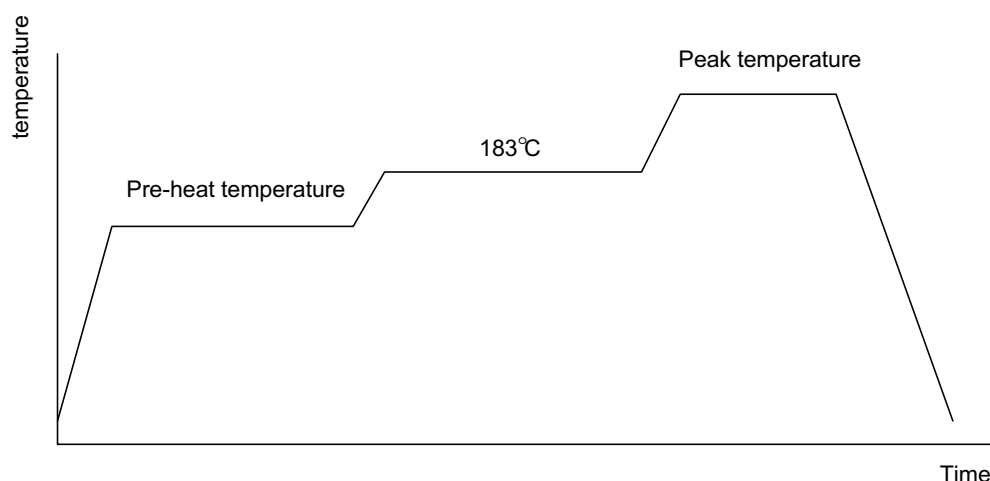

Classification Reflow Profiles

	Convection or IR/ Convection	VPR
Average ramp-up rate(183°C to Peak)	3°C/second max.	10 °C /second max.
Preheat temperature 125 ± 25°C)	120 seconds max	
Temperature maintained above 183°C	60 – 150 seconds	
Time within 5°C of actual peak temperature	10 –20 seconds	60 seconds
Peak temperature range	220 +5/-0°C or 235 +5/-0°C	215-219°C or 235 +5/-0°C
Ramp-down rate	6 °C /second max.	10 °C /second max.
Time 25°C to peak temperature	6 minutes max.	

Package Reflow Conditions

pkg. thickness ≥ 2.5mm and all bgas	pkg. thickness < 2.5mm and pkg. volume ≥ 350 mm ³	pkg. thickness < 2.5mm and pkg. volume < 350mm ³
Convection 220 +5/-0 °C		Convection 235 +5/-0 °C
VPR 215-219 °C		VPR 235 +5/-0 °C
IR/Convection 220 +5/-0 °C		IR/Convection 235 +5/-0 °C

Reliability test program

Test item	Method	Description
SOLDERABILITY	MIL-STD-883D-2003	245°C , 5 SEC
HOLT	MIL-STD-883D-1005.7	1000 Hrs Bias @ 125 °C
PCT	JESD-22-B, A102	168 Hrs, 100 % RH , 121°C
TST	MIL-STD-883D-1011.9	-65°C ~ 150°C, 200 Cycles
ESD	MIL-STD-883D-3015.7	VHBM > 2KV, VMM > 200V
Latch-Up	JESD 78	10ms , $I_{tr} > 100mA$

Carrier Tape & Reel Dimensions

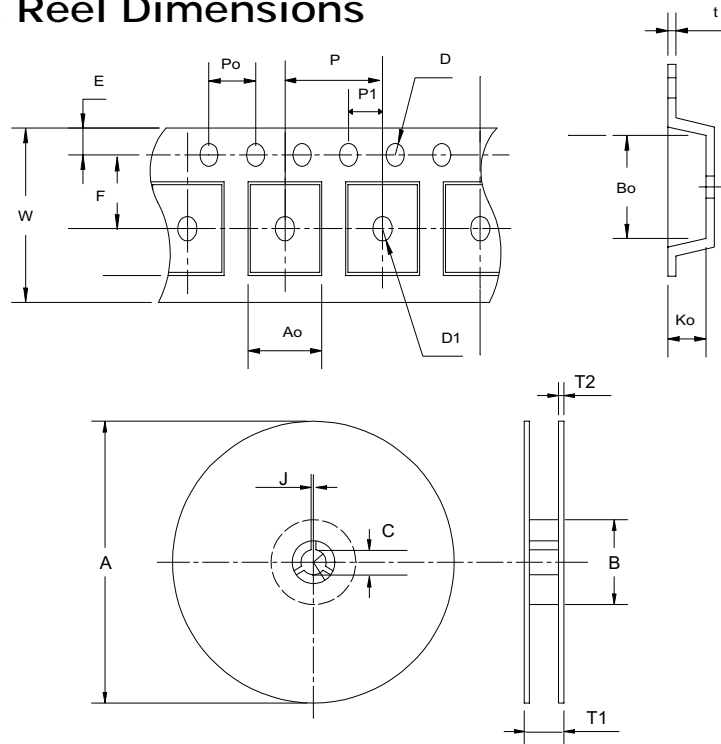

Application	A	B	C	J	T1	T2	W	P	E
SOP-8	330±1	62 ± 1.5	12.75 + 0.15	2 + 0.5	12.4 +0.2	2± 0.2	12 + 0.3 - 0.1	8± 0.1	1.75± 0.1
TSSOP- 8	330 ± 1	62 ± 1.5	12.75 ±0.15	2 + 0.5	12.4 + 0.2	2 ± 0.2	12 + 0.3 - 0.1	8.0 ± 0.1	.75 ± 0.1
Application	F	D	D1	Po	P1	Ao	Bo	Ko	t
SOP-8	5.5 ± 0.1	1.55±0.1	1.5 + 0.25	4.0 ± 0.1	2.0 ± 0.1	6.4 ± 0.1	5.2± 0.1	2.1± 0.1	0.3±0.013
TSSOP- 8	5.5 ± 0.	1.5 + 0.1	1.5 + 0.1	4.0 ± 0.1	2.0 ± 0.1	7.0 ± 0.1	3.6 ± 0.3	1.6 ± 0.1	0.3 ±0.013

(mm)

Cover Tape Dimensions

Carrier Width	12
Cover Tape Width	9.3

(mm)

Customer Service

Anpec Electronics Corp.

Head Office :

5F, No. 2 Li-Hsin Road, SBIP,
Hsin-Chu, Taiwan, R.O.C.

Tel : 886-3-5642000

Fax : 886-3-5642050

Taipei Branch :

7F, No. 137, Lane 235, Pac Chiao Rd.,
Hsin Tien City, Taipei Hsien, Taiwan, R. O. C.

Tel : 886-2-89191368

Fax : 886-2-89191369