

## 2.1 Channel PWM Controller

### DESCRIPTION

The WM8602 comprises a high performance stereo + sub PWM digital power amplifier controller. Simply by adding appropriate power output stages a 2.1 channel power amplifier may be built. Two identical full audio bandwidth channels, plus a reduced bandwidth sub channel are provided as PWM outputs.

The PCM to PWM converter supports up to 2 channels of audio, in PCM input formats. The on board bass management enables the generation of a sub channel from the stereo PCM data.

A Graphic Equaliser function is provided, plus selectable high frequency equalisation to suit different speaker types. Independent volume control for each channel is provided.

The WM8602 PWM controller is compatible with integrated switching output stages available from a number of vendors or alternatively may be used with a discrete output stage configuration and achieve similar levels of performance.

A Dynamic Peak Compressor with programmable attack and decay times is included, which allows headroom for tone control, bass management and extra digital gain to be provided, without clipping occurring.

A Synchroniser allows slaving to LRCLK, thus making the WM8602 independent of source MCLK frequency and jitter.

The device is controlled via a 2/3 wire serial interface. The interface provides access to all features including channel selection, volume controls, mutes, de-emphasis and power management facilities. The device is supplied in a 28-pin SSOP package.

### FEATURES

- Multi-channel PWM audio amplifier controller
- Supports Stereo input
- Supports stereo or 2.1 with sub channel generation
- PWM Audio Performance with typical output stage
  - 100dB SNR ('A' weighted @ 48kHz)
  - 0.01% THD @ 1Watt
  - 0.1% THD @ 30Watt
- Integrated Bass Management support with adjustable filter
- Integrated 4-band Graphic Equaliser
- Adjustable output stage filter compensation for different speakers
- Volume control on each channel +24dB to -103.5dB in 0.5dB steps, with volume ramping and auto-mute functions
- Programmable Dynamic Peak Compressor avoids clipping even at high volume settings
- Internal PLL and optional crystal oscillator, supporting Audio and MPEG standards
- 2/3-Wire MPU Serial Control Interface
- Master or Slave Cloning Mode
- Programmable Audio Data Interface Modes
  - I<sup>2</sup>S, Left, Right Justified or DSP
  - 16/20/24/32 bit Word Lengths
- De-emphasis support for stereo
- CMOS digital outputs

### APPLICATIONS

- Hi-Fi systems
- Automotive Audio
- Boombox
- Active Speakers

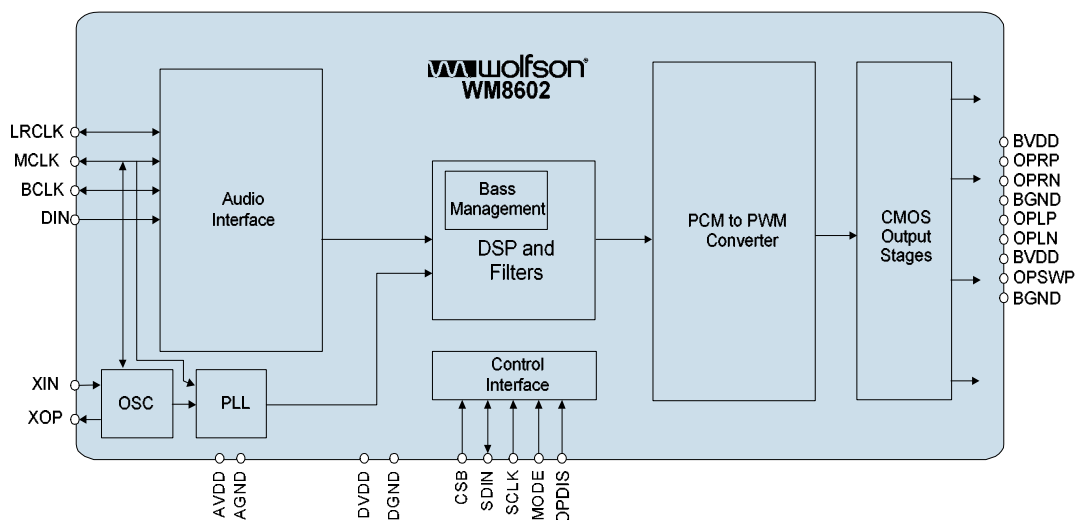

## TABLE OF CONTENTS

<b>DESCRIPTION .....</b>	<b>1</b>
<b>FEATURES.....</b>	<b>1</b>
<b>APPLICATIONS .....</b>	<b>1</b>
<b>TABLE OF CONTENTS .....</b>	<b>2</b>
<b>PIN CONFIGURATION.....</b>	<b>3</b>
<b>ORDERING INFORMATION .....</b>	<b>3</b>
<b>ABSOLUTE MAXIMUM RATINGS .....</b>	<b>5</b>
<b>ELECTRICAL CHARACTERISTICS .....</b>	<b>6</b>
<b>TERMINOLOGY .....</b>	<b>7</b>
<b>POWER CONSUMPTION .....</b>	<b>7</b>
<b>SIGNAL TIMING REQUIREMENTS .....</b>	<b>8</b>
POWER SUPPLY.....	8
MASTER CLOCK TIMING .....	8
AUDIO INTERFACE TIMING – MASTER MODE .....	9
<b>DEVICE DESCRIPTION .....</b>	<b>14</b>
INTRODUCTION.....	14
SIGNAL PATH.....	14
DIGITAL AUDIO INTERFACE .....	15
AUDIO INTERFACE CONTROL.....	18
MASTER CLOCK AND AUDIO SAMPLE RATES.....	19
SYNCHRONISER.....	22
CONTROL INTERFACE OPERATION.....	23
INPUT PROCESSOR.....	24
<b>BASS MANAGEMENT .....</b>	<b>25</b>
GRAPHIC EQUALISER.....	26
DIGITAL DEEMPHASIS .....	28
DIGITAL VOLUME CONTROL .....	28
SOFT MUTE AND AUTO-MUTE .....	29
DYNAMIC PEAK COMPRESSOR .....	31
INTERPOLATION FILTERS .....	34
PCM TO PWM CONVERTER .....	35
STANDBY, OUTPUT DISABLE AND RESET MODES.....	36
EXTERNAL POWER SUPPLY CLOCK.....	37
<b>REGISTER MAP.....</b>	<b>39</b>
FILTER RESPONSES .....	40
DIGITAL DE-EMPHASIS CHARACTERISTICS.....	41
<b>APPLICATION NOTES .....</b>	<b>42</b>
START-UP .....	42
POWER SUPPLY CONNECTIONS.....	43
<b>APPLICATIONS INFORMATION .....</b>	<b>44</b>
RECOMMENDED EXTERNAL COMPONENTS.....	44
RECOMMENDED EXTERNAL COMPONENTS VALUES.....	44
<b>PACKAGE DIMENSIONS .....</b>	<b>45</b>
<b>IMPORTANT NOTICE .....</b>	<b>46</b>
ADDRESS:.....	46

## PIN CONFIGURATION

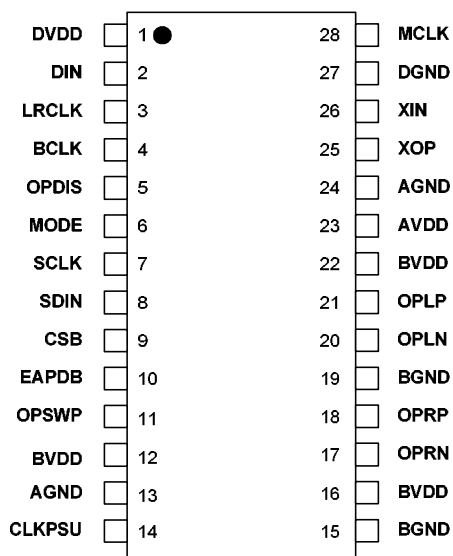

## ORDERING INFORMATION

DEVICE	TEMPERATURE RANGE	PACKAGE	MOISTURE LEVEL SENSITIVITY	PEAK SOLDERING TEMPERATURE
WM8602SEDS/V	-25 to + 85°C	28-pin SSOP (lead free)	MSL1	260°C
WM8602SEDS/RV	-25 to + 85°C	28-pin SSOP (lead free, tape and reel)	MSL1	260°C

**PIN DESCRIPTION**

PIN	NAME	TYPE	DESCRIPTION
1	DVDD	Supply	Digital positive supply
2	DIN	Digital Input	L/R channel data input
3	LRCLK	Digital Input/Output	Left/right word clock
4	BCLK	Digital IO	Audio interface bit clock
5	OPDIS	Digital Input p.d.	Output disable
6	MODE	Digital Input p.d.	2/3 Wire control interface mode
7	SCLK	Digital Input	Serial interface clock
8	SDIN	Digital Input/Output	Serial interface data
9	CSB	Digital Input	Serial interface load signal
10	EAPDB	Digital Output	External output stage power down
11	OPSWP	Digital Output	PWM output positive Subwoofer channel
12	BVDD	Supply	PWM output buffer positive supply
13	AGND	Supply	Analogue negative supply
14	CLKPSU	Digital Output	Clock for external PSU
15	BGND	Supply	PWM output buffer ground supply
16	BVDD	Supply	PWM output buffer positive supply
17	OPRN	Digital Output	PWM output negative right channel
18	OPRP	Digital Output	PWM output positive right channel
19	BGND	Supply	PWM output buffer ground supply
20	OPLN	Digital Output	PWM output negative left channel
21	OPLP	Digital Output	PWM output positive left channel
22	BVDD	Supply	PWM output buffer positive supply
23	AVDD	Analogue Supply	Analogue positive supply
24	AGND	Analogue Supply	Analogue negative supply
25	XOP	Digital Output	Crystal oscillator output connection
26	XIN	Digital Input	Crystal oscillator input connection (may be left unconnected in slave mode)
27	DGND	Supply	Digital negative supply
28	MCLK	Digital Input/Output	Master clock; 256, 384, 512 fs (fs = word clock frequency) or 27MHz

**Notes:** Digital input pins have Schmitt trigger input buffers. Pins marked 'p.u.' or 'p.d.' have internal pull-up or pull down.

## ABSOLUTE MAXIMUM RATINGS

Absolute Maximum Ratings are stress ratings only. Permanent damage to the device may be caused by continuously operating at or beyond these limits. Device functional operating limits and guaranteed performance specifications are given under Electrical Characteristics at the test conditions specified.



ESD Sensitive Device. This device is manufactured on a CMOS process. It is therefore generically susceptible to damage from excessive static voltages. Proper ESD precautions must be taken during handling and storage of this device.

Wolfson tests its package types according to IPC/JEDEC J-STD-020B for Moisture Sensitivity to determine acceptable storage conditions prior to surface mount assembly. These levels are:

MSL1 = unlimited floor life at <30°C / 85% Relative Humidity. Not normally stored in moisture barrier bag.

MSL2 = out of bag storage for 1 year at <30°C / 60% Relative Humidity. Supplied in moisture barrier bag.

MSL3 = out of bag storage for 168 hours at <30°C / 60% Relative Humidity. Supplied in moisture barrier bag.

The Moisture Sensitivity Level for each package type is specified in Ordering Information.

CONDITION	MIN	MAX
Analogue supply voltage (AVDD)	-0.3V	+5V
Digital supply voltage (DVDD)	-0.3V	+5V
PWM output buffer supply voltage (BVDD)	-0.3V	+5V
Voltage range inputs	DGND -0.3V	DVDD +0.3V
Master Clock Frequency	10MHz	50MHz
Operating temperature range, T <sub>A</sub>	-20°C	+85°C
Storage temperature	-65°C	+150°C

### Notes:

1. GND power supplies (i.e. AGND, DGND, and BGND) must always be within 0.3V of each other.
2. VDD power supplies (i.e. AVDD, DVDD, and BVDD) must always be within 0.3V of each other.

## RECOMMENDED OPERATING CONDITIONS

PARAMETER	SYMBOL	TEST CONDITIONS	MIN	TYP	MAX	UNIT
Analogue supply range	AVDD		2.7		3.6	V
Digital supply range	DVDD		2.7		3.6	V
PWM output buffer supply	BVDD		2.7		3.6	V
Ground	AGND, DGND, BGND			0		V

## ELECTRICAL CHARACTERISTICS

### Test Conditions

AVDD, BVDD, DVDD = 2.7 to 3.3V, AGND, DGND, BGND = 0V,  $T_A$  = -20 to +85°C,  $f_s$  = 44.1kHz/48kHz, MCLK = 256fs unless stated.

PARAMETER	SYMBOL	TEST CONDITIONS	MIN	TYP	MAX	UNIT
Input capacitance	$C_i$			3	4	pF
Input leakage	$I_{leak}$			±0.1	±0.5	µA
<b>Oscillator</b>						
Input XIN LOW level	$V_{X_{IL}}$		0		0.44	V
Input XIN HIGH level	$V_{X_{IH}}$		0.77		AVDD	V
Input XIN capacitance	$C_{X_i}$			4	5	pF
Input XIN leakage	$I_{X_{leak}}$		0.10	0.11	0.13	mA
Output XOP LOW	$V_{X_{OL}}$	15pF load capacitors	0.1	0.4	0.5	V
Output XOP HIGH	$V_{X_{OH}}$	15pF load capacitors	1.2	1.3	1.4	V
<b>Digital Logic Levels (CMOS Levels)</b>						
Input LOW level	$V_{IL}$				0.3 x DVDD	V
Input HIGH level	$V_{IH}$		0.7 x DVDD			V
Pull-up/pull-down resistance			100	200	400	kΩ
Output LOW	$V_{OL}$	$I_{OL}=+1mA$			0.1 x DVDD	V
Output HIGH	$V_{OH}$	$I_{OL}=-1mA$	0.9 x DVDD			V
<b>Digital Logic Levels (LVDS Levels)</b>						
Output differential voltage	$V_{OD}$	$R_T=100\Omega$	200	350	500	mV
Offset voltage	$V_{OS}$	$R_T=100\Omega$	0.95	1.25	1.4	V
Termination load	$R_T$	20pF load		100		Ω
<b>PCM to PWM converter</b>						
Digital SNR		L, R		105		dB
Typical SNR with output stage (A-weighted)		L, R		100		dB
Typical Dynamic Range with output stage		L, R		100		dB
Digital THD+N at 0dBfs		L, R		0.001		%
Typical THD+N at 30Watt with output stage		L, R		0.1		%
Typical THD+N at 1Watt with typical output stage		L, R		0.01		%
Typical IMD (CCIF – 19/20kHz)		L, R		-70		dBFS
Typical IMD (SMPTE – 60Hz/7kHz)		L, R		-70		dBFS
<b>PCM to PWM converter</b>						
Digital SNR		Subwoofer <sup>5</sup>		105		
Typical SNR with output stage (A-weighted)		Subwoofer <sup>5</sup>		100		
Typical Dynamic Range with output stage		Subwoofer <sup>5</sup>		100		
Digital THD+N at 0dBfs		Subwoofer <sup>5</sup>		0.001		
Typical THD+N at 30Watt with output stage		Subwoofer <sup>5</sup>		0.1		
Typical THD+N at 1Watt with typical output stage		Subwoofer <sup>5</sup>		0.01		
Typical IMD (CCIF – 19/20kHz)		Subwoofer <sup>5</sup>		-70		
Typical IMD (SMPTE – 60Hz/7kHz)		Subwoofer <sup>5</sup>		-70		

**Test Conditions**

AVDD, BVDD, DVDD = 2.7 to 3.3V, AGND, DGND, BGND = 0V, T<sub>A</sub> = -20 to +85°C, fs = 44.1kHz/48kHz, MCLK = 256fs unless stated.

PARAMETER	SYMBOL	TEST CONDITIONS	MIN	TYP	MAX	UNIT
PWM buffer drive strength	I <sub>source</sub>	CMOS	25 <sup>4</sup>			mA
	I <sub>sink</sub>	20pF load	25 <sup>4</sup>			mA
PWM pulse repetition rate	f <sub>PWM</sub>	fs = 44.1kHz		352.8		kHz
		fs = 48kHz		384		kHz

**Notes:**

- Ratio of output level with 1kHz full scale input, to the output level with all zeros into the digital input, measured 'A' weighted over a 20Hz to 20kHz bandwidth.
- All performance measurements done with 20kHz AES17 low pass filter, except where noted an A-weight filter is used. Failure to use such a filter will result in higher THD+N and lower SNR and Dynamic Range readings than are found in the Electrical Characteristics. The low pass filter removes out of band noise; although it is not audible it may affect dynamic specification values.
- The XIN input supports both a clock as well as a crystal input.
- Parameter guaranteed by design.
- Validated using the following filter

PARAMETER	SYMBOL	TEST CONDITIONS	MIN	TYP	MAX	UNIT
<b>Filter</b>						
Stopband		-3dB		1.00		kHz

**Note:** A third order differential RC filter has been used

**TERMINOLOGY**

- Signal-to-noise ratio (dB) - SNR is a measure of the difference in level between the full scale output and the output with no signal applied.
- Dynamic range (dB) - DNR is a measure of the difference between the highest and lowest portions of a signal. Normally a THD+N measurement at 60dB below full scale. The measured signal is then corrected by adding the 60dB to it (e.g. THD+N @ -60dB= -32dB, DR= 92dB).
- THD+N (dB) - THD+N is a ratio, of the RMS values, of (Noise + Distortion)/Signal.

**POWER CONSUMPTION**

MODE DESCRIPTION	TYPICAL SUPPLY CURRENTS [mA]			TOTAL CURRENT [mA]	TOTAL POWER [mW]
	I <sub>AVDD</sub>	I <sub>DVDD</sub>	I <sub>BVDD</sub>		
<b>AVDD, DVDD, BVDD = 3.3V</b>					
OFF	0	0	0	0	0
Standby	0.02	0.28	0	0.30	0.99
Mute	1.76	27.2	7.55	36.5	121
Stereo	1.76	27.7	7.55	37.0	122
2.1					

**Table 1 Supply Current Consumption**

**Notes:**

- T<sub>A</sub> = +25°C, Slave Mode, fs = 48kHz, MCLK = 27 kHz, 24-bit data
- All figures are kHz 1kHz input sine wave @ 0dB.

## SIGNAL TIMING REQUIREMENTS

### POWER SUPPLY

#### Test Conditions

AGND, DGND, BGDN = 0V,  $T_A = +25^\circ\text{C}$

PARAMETER	SYMBOL	MIN	TYP	MAX	UNIT
<b>Power Supply Timing Information</b>					
AVDD: rise time 10% to 90% AVDD	$t_{AR}$	0.2		50	ms
DVDD: rise time 10% to 90% DVDD	$t_{DR}$	0.2		50	ms
BVDD: rise time 10% to 90% BVDD	$t_{BR}$	0.2		50	ms

Table 2 Power Supply Timing Requirements

### MASTER CLOCK TIMING

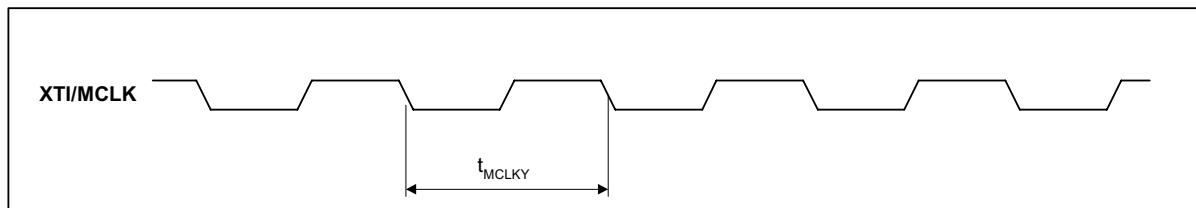

Figure 1 Master Clock Timing Requirements

#### Test Conditions

AVDD, DVDD, BVDD = 3.3V, AGND, DGND, BGDN = 0V,  $T_A = +25^\circ\text{C}$

PARAMETER	SYMBOL	MIN	TYP	MAX	UNIT
<b>System Clock Timing Information</b>					
XTI/MCLK System clock cycle time	$t_{MCLKY}$	20		100	ns
XTI/MCLK Duty cycle		40:60		60:40	%
XTI/MCLK Period Jitter				200	ps
XTI/MCLK Rise/Fall times 10% to 90% AVDD				3	ns

Table 3 Master Clock Timing Requirements



## AUDIO INTERFACE TIMING – MASTER MODE

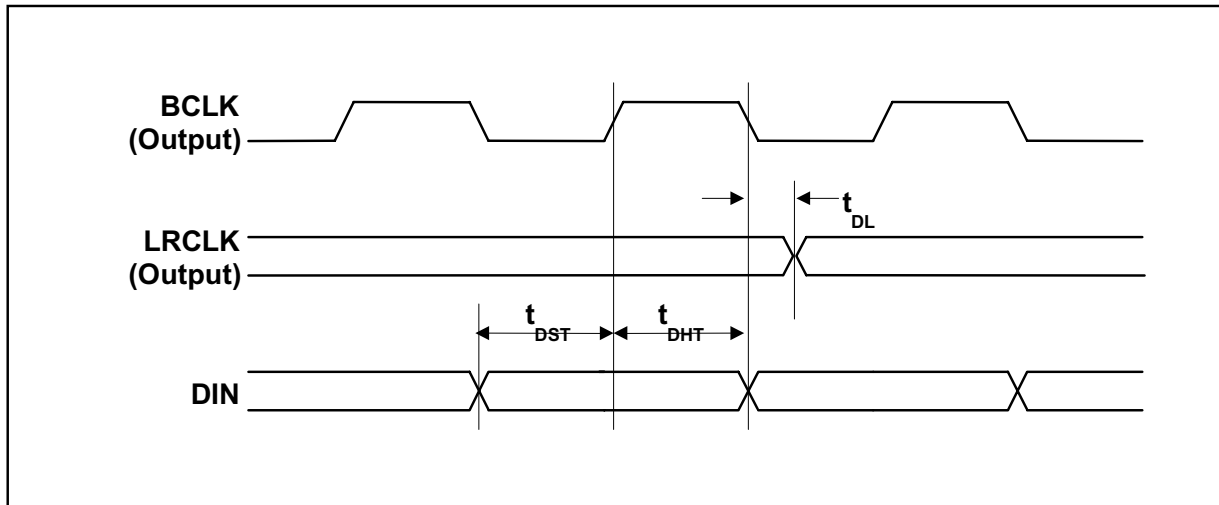

Figure 2 Digital Audio Data Timing – Master Mode (see Control Interface)

**Test Conditions**

AVDD, DVDD, BVDD = 3.3V, AGND, DGND, BGDN = 0V,  $T_A = +25^\circ\text{C}$ , Slave Mode,  $f_s = 48\text{kHz}$ , MCLK = 256fs, 24-bit data, unless otherwise stated.

PARAMETER	SYMBOL	MIN	TYP	MAX	UNIT
<b>Audio Data Input Timing Information</b>					
LRCLK propagation delay from BCLK falling edge	$t_{DL}$			10	ns
DIN setup time to BCLK rising edge	$t_{DST}$	10			ns
DIN hold time from BCLK rising edge	$t_{DHT}$	10			ns

Table 4 Audio Interface Timing – Master Mode

**AUDIO INTERFACE TIMING – SLAVE MODE**

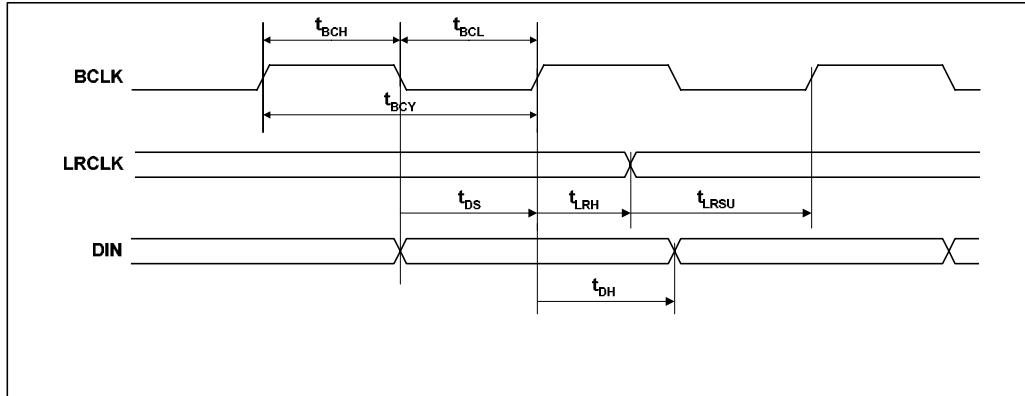

**Figure 3 Digital Audio Data Timing – Slave Mode**

**Test Conditions**

AVDD, DVDD, BVDD = 3.3V, AGND, DGND, BGND = 0V, T<sub>A</sub> = +25°C, Slave Mode, fs = 48kHz, MCLK = 256fs, 24-bit data, unless otherwise stated.

PARAMETER	SYMBOL	MIN	TYP	MAX	UNIT
<b>Audio Data Input Timing Information</b>					
BCLK cycle time	t <sub>BCY</sub>	50			ns
BCLK pulse width high	t <sub>BCH</sub>	20			ns
BCLK pulse width low	t <sub>BCL</sub>	20			ns
BCLK rise/fall times				5	ns
LRCLK set-up time to BCLK rising edge	t <sub>LRSU</sub>	10			ns
LRCLK hold time from BCLK rising edge	t <sub>LRH</sub>	10			ns
LRCLK rise/fall times				5	ns
DIN hold time from BCLK rising edge	t <sub>DH</sub>	10			ns

**Table 5 Audio Interface Timing – Slave Mode**

**Note:** BCLK period should always be greater than or equal to MCLK period.

## CONTROL INTERFACE TIMING – 3-WIRE MODE

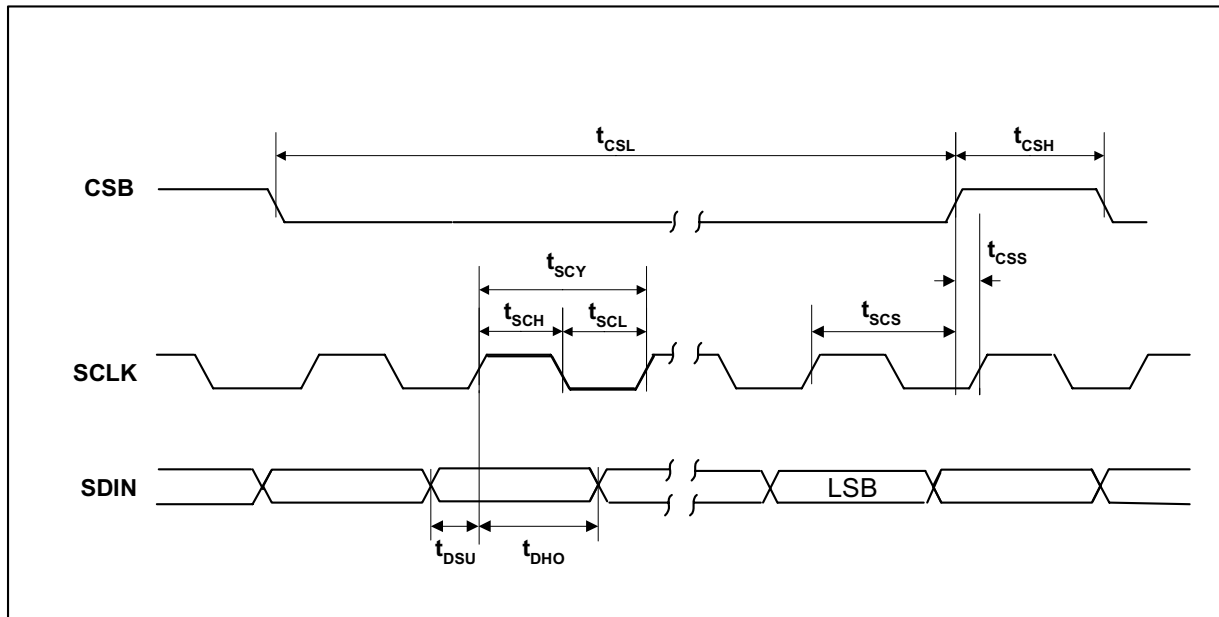

Figure 4 Control Interface Timing – 3-Wire Serial Control Mode

## Test Conditions

AVDD, DVDD, BVDD = 3.3V, AGND, DGND, BGND = 0V,  $T_A = +25^\circ\text{C}$ , Slave Mode,  $f_s = 48\text{kHz}$ , MCLK = 256fs, 24-bit data, unless otherwise stated.

PARAMETER	SYMBOL	MIN	TYP	MAX	UNIT
<b>Program Register Input Information</b>					
SCLK rising edge to CSB rising edge	$t_{SCS}$	60			ns
SCLK pulse cycle time	$t_{SCY}$	80			ns
SCLK pulse width low	$t_{SCL}$	30			ns
SCLK pulse width high	$t_{SCH}$	30			ns
SDIN to SCLK set-up time	$t_{DSU}$	20			ns
SCLK to SDIN hold time	$t_{DHO}$	20			ns
CSB pulse width low	$t_{CSL}$	20			ns
CSB pulse width high	$t_{CSH}$	20			ns
CSB rising to SCLK rising	$t_{CSS}$	20			ns
Pulse width of spikes that will be suppressed	$t_{ps}$	2		8	ns

Table 6 Control Interface Timing – 3-Wire Serial Control Mode

**CONTROL INTERFACE TIMING – 2-WIRE MODE**

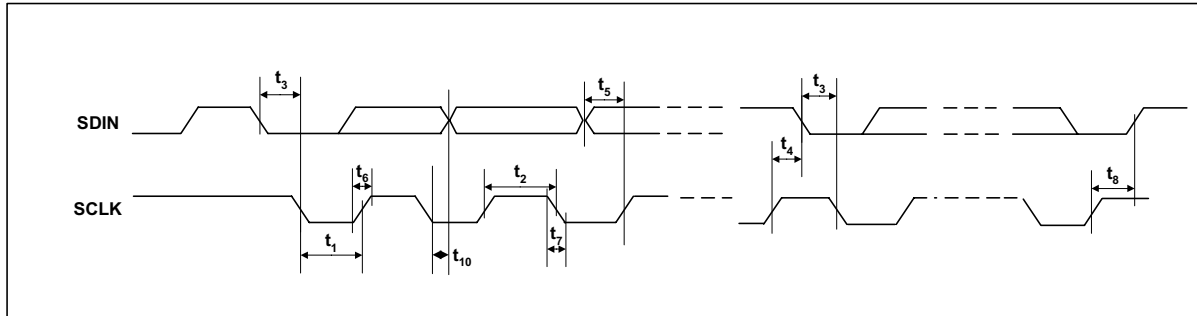

**Figure 5 Control Interface Timing – 2-Wire Serial Control Mode**

**Test Conditions**

AVDD, DVDD, BVDD = 3.3V, AGND, DGND, BGND = 0V,  $T_A = +25^\circ\text{C}$ , Slave Mode,  $f_s = 48\text{kHz}$ , MCLK = 256fs, 24-bit data, unless otherwise stated.

PARAMETER	SYMBOL	MIN	TYP	MAX	UNIT
<b>Program Register Input Information</b>					
SCLK Frequency				400	kHz
SCLK Low Pulse-Width	$t_1$	600			ns
SCLK High Pulse-Width	$t_2$	1.3			us
Hold Time (Start Condition)	$t_3$	600			ns
Setup Time (Start Condition)	$t_4$	600			ns
Data Setup Time	$t_5$	100			ns
SDIN, SCLK Rise Time	$t_6$			300	ns
SDIN, SCLK Fall Time	$t_7$			300	ns
Setup Time (Stop Condition)	$t_8$	600			ns
Data Hold Time	$t_9$			900	ns
Pulse width of spikes that will be suppressed	$t_{ps}$	2		8	ns

**Table 7 Control Interface Timing – 2-Wire Serial Control Mode**

## PWM OUTPUT TIMING

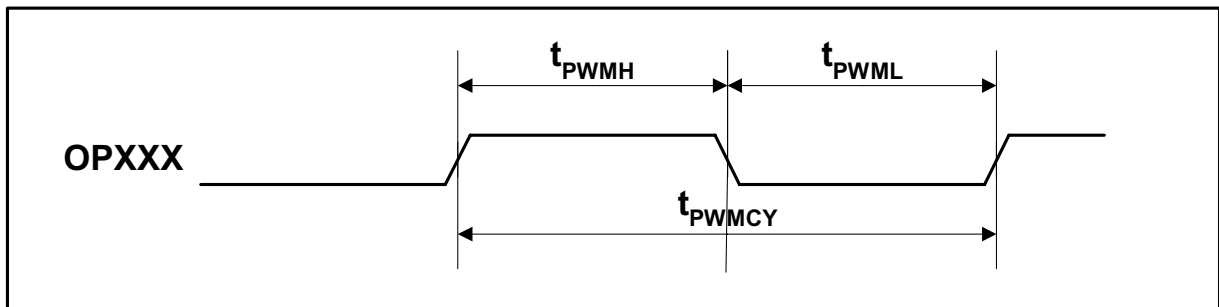

Figure 6 PWM Output Timing

## Test Conditions

AVDD, DVDD, BVDD = 2.7 to 3.3V, AGND, DGND, BGND = 0V,  $T_A$  = -20 to +85°C, Slave Mode,  $f_s$  = 48kHz, MCLK = 256fs, 24-bit data, unless otherwise stated.

PARAMETER	SYMBOL/NOTE	MIN	TYP	MAX	UNIT
<b>Program Register Input Information</b>					
PWM Frequency	$t_{PWMCY}$		384		kHz
PWM Low Pulse-Width	$t_{PWMML}$	122			ns
PWM High Pulse-Width	$t_{PWMH}$	122			ns
<b>CMOS Mode</b>					
PWM Rise Time <sup>1</sup>	20pF load		1.5	2.3	ns
PWM Fall Time <sup>1</sup>	20pF load		1.5	2.3	ns

Table 8 PWM Interface Timing

## Note:

1. Parameter guaranteed by design

## DEVICE DESCRIPTION

### INTRODUCTION

The WM8602 is a high-performance multi-channel Pulse-Width Modulation (PWM) digital power amplifier controller. The device accepts up to 2 channels of audio in PCM input format, and outputs 2 PWM full-bandwidth channels, plus a PWM sub-woofer channel. The outputs are suitable for directly driving integrated switching output stages available from a number of vendors. The device is also compatible with discrete MOSFET output stages. In both cases, Wolfson Microelectronics offer Reference Designs for complete PWM digital power amplifiers.

The WM8602 has a configurable input processor which accepts Stereo channels of PCM audio and outputs Stereo or 2.1 outputs. The sub channel is generated from the filtered sum of the low frequency components of the input data.

The device has a Bass Management function, which has low-pass and high-pass filters for feeding the sub channel and main output channels. It also provides selectable boost for the LFE channel. Each channel can be configured to drive either "large" full-range speakers or "small" satellite speakers with limited bass capability.

A Tone Control function is provided, plus selectable high frequency equalisation to compensate for different loudspeaker characteristics. Independent volume control is provided for all channels, with comprehensive mute features.

A Dynamic Peak Compressor with programmable attack and decay times is included, which allows headroom for tone control, bass management and extra digital gain to be provided, without clipping occurring.

The device is controlled via a 2/3 wire serial interface. The interface provides access to all features including channel selection, volume controls, mute, de-emphasis and power management facilities.

### SIGNAL PATH

The WM8602 receives digital input data via a 2-channel digital audio interface. The data is processed in turn by the Input Processor, Bass Management and Equalisation, Volume Control and Dynamic Peak Compressors, Interpolation Filters, and PCM-PWM Converters, as shown in Figure 7. The PWM signals are output via CMOS drivers.

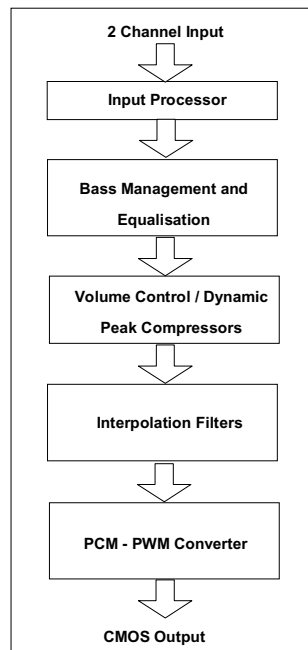

Figure 7 Signal Processing Block Diagram

Parameter	Group Delay	Unit	fs=48kHz	Unit
L / R channel	47	samples	1.0	ms
SUB channel	22	samples	0.5	ms

**Table 9 Signal Path Group Delay**

**Note:** The shorter delay on the SUB channel will not significantly affect audio performance. (It is equivalent to moving the subwoofer forwards by about 15cm.)

## DIGITAL AUDIO INTERFACE

The digital audio interface is used for inputting audio data into the WM8602. It uses five pins:

- DIN: L+R channel data input
- LRCLK: Data alignment clock
- BCLK: Bit clock, for synchronisation

The clock signals BCLK and LRCLK can be outputs when the WM8602 operates as a master, or inputs when it is a slave (see Master and Slave Mode Operation, below).

### MASTER AND SLAVE MODE OPERATION

The WM8602 can be configured as either a master or slave mode device. As a master device the WM8602 generates BCLK and LRCLK and thus controls sequencing of the data transfer on the data channels. In slave mode, the WM8602 receives data and clock signals over the digital audio interface. The mode can be selected by writing to the MS bit (see Table 23). Master and slave modes are illustrated below.

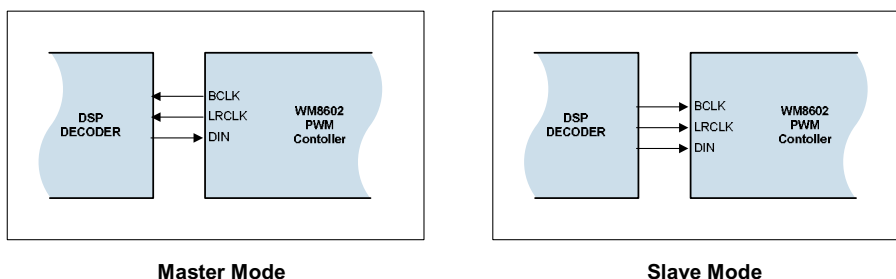

**Figure 8 Operation Mode**

### AUDIO DATA FORMATS

In Left Justified mode, the MSB is available on the first rising edge of BCLK following a LRCLK. Audio data is applied to the internal filters via the Digital Audio Interface. 5 popular interface formats are supported:

- Left Justified mode
- Right Justified mode
- I<sup>2</sup>S mode
- DSP mode A
- DSP mode B

All 5 formats send the MSB first and support word lengths of 16, 20, 24 and 32 bits. Except that 32 bit data is not supported in right justified mode. DIN and LRCLK are sampled on the rising, or falling edge of BCLK.

In left justified, right justified and I<sup>2</sup>S modes the digital audio interface receives data on the DIN input. Audio Data for each stereo channel is time multiplexed with LRCLK indicating whether the left or right channel is present. LRCLK is also used as a timing reference to indicate the beginning or end of the data words.

In left justified, right justified and I<sup>2</sup>S modes, the minimum number of BCLKs per DACLR period is 2 times the selected word length. LRCLK must be high for a minimum of word length BCLKs and low for a minimum of word length BCLKs. Any mark to space ratio on LRCLK is acceptable provided the above requirements are met.

In DSP mode A or B, all channels are time multiplexed onto DIN. LRCLK is used as a frame sync signal to identify the MSB of the first word. The minimum number of BCLKs per LRCLK period is 8 times the selected word length. Any mark to space ratio is acceptable on LRCLK provided the rising edge is correctly positioned (see Figure 9, Figure 10 and Figure 11).

**LEFT JUSTIFIED MODE**

In left justified mode, the MSB is sampled on the first rising edge of BCLK following a LRCLK transition. LRCLK is high during the left samples and low during the right samples.

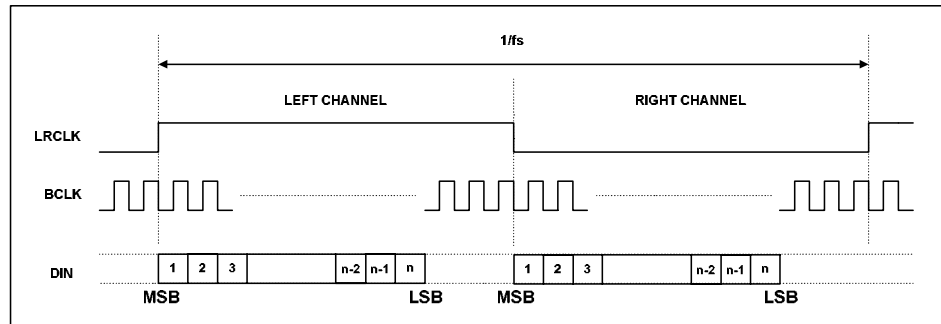

Figure 9 Left Justified Mode Timing Diagram

**RIGHT JUSTIFIED MODE**

In right justified mode, the LSB is sampled on the rising edge of BCLK preceding a LRCLK transition. LRCLK is high during the left samples and low during the right samples.

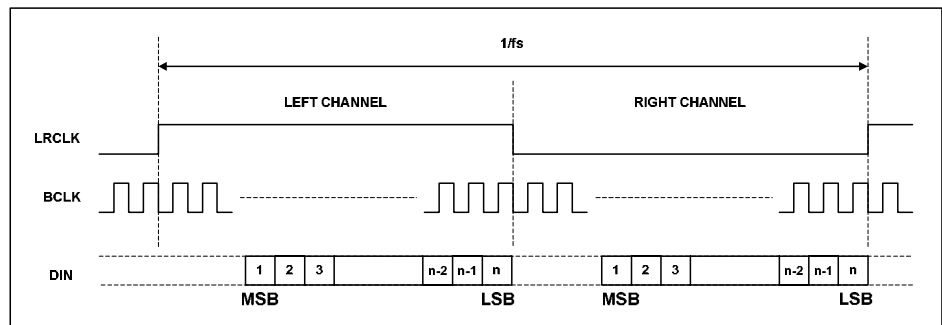

Figure 10 Right Justified Mode Timing Diagram



**I<sup>2</sup>S MODE**

In I<sup>2</sup>S mode, the MSB is sampled on the second rising edge of BCLK following a LRCLK transition. LRCLK is low during the left samples and high during the right samples.

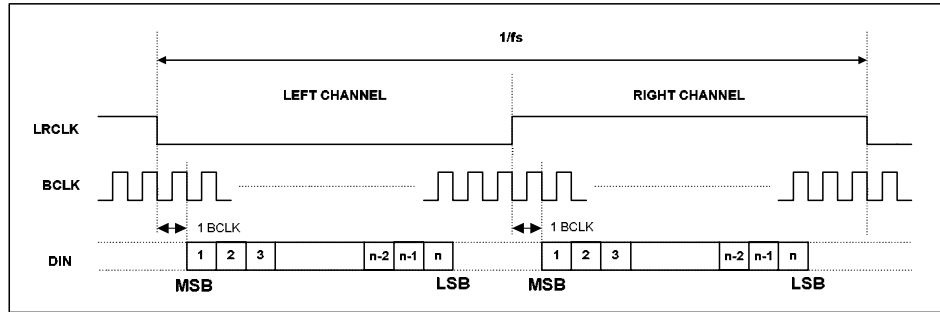

Figure 11 I<sup>2</sup>S Mode Timing Diagram

**DSP MODE A AND B**

In DSP mode, the Left channel MSB is available on either the 1<sup>st</sup> (mode B) or 2<sup>nd</sup> (mode A) rising edge of BCLK (selectable by LRP) following a rising edge of LRCLK. Right channel data immediately follows left channel data. Depending on word length, BCLK frequency and sample rate, there may be unused BCLK cycles between the LSB of the right channel data and the next sample.

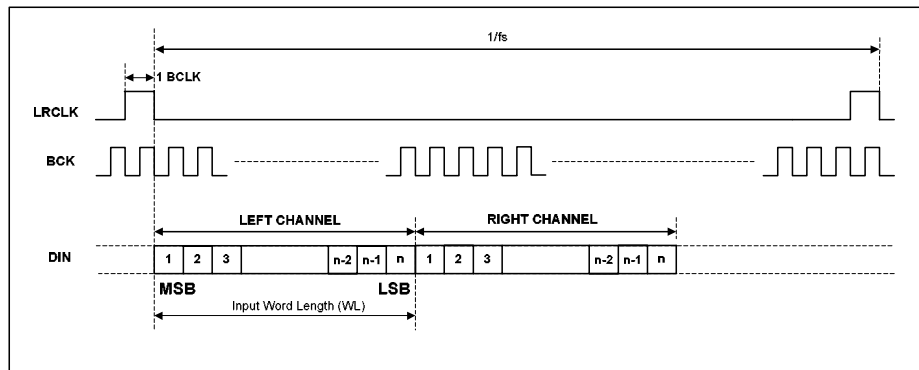

Figure 12 DSP Mode A Timing Diagram

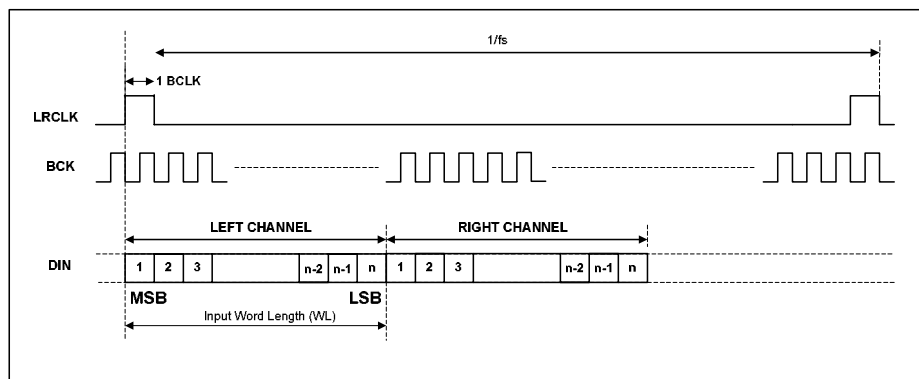

Figure 13 DSP Mode B Timing Diagram

No BCLK edges are allowed between the data words.

MODE	INPUT FORMAT (ORDER)	SUPPORTED MODES
Stereo	L, R	No restrictions apply

Table 10 DSP Mode Input Format

## AUDIO INTERFACE CONTROL

The register bits controlling audio format, word length and master/slave mode are summarised below. MS selects audio interface operation in master or slave mode. In Master mode BCLK and LRCLK are outputs and the frequency of LRCLK is set by the sample rate control bits SR[3:0]. In Slave mode BCLK and LRCLK are inputs (refer to Table 12 for sample rate control in this case).

REGISTER ADDRESS	BIT	LABEL	DEFAULT	DESCRIPTION
R2 (02h) Audio IF Format	8	BCLKINV	0	BCLK invert bit (for master and slave modes) 0 = BCLK not inverted 1 = BCLK inverted
	7	MS	0	Master / Slave Mode Control 1 = Enable Master Mode 0 = Enable Slave Mode
	6	LRSWAP	0	Left/Right channel swap 1 = swap left and right data in audio interface 0 = output left and right data as normal
	4	LRP	0	Right, left and I <sup>2</sup> S modes – LRCLK polarity 1 = invert LRCLK polarity 0 = normal LRCLK polarity (as show in e.g. Figure 12)
	3:2	WL[1:0]	10	DSP Mode – A/B select 1 = MSB is available on 1st BCLK rising edge after LRC rising edge (mode B) 0 = MSB is available on 2nd BCLK rising edge after LRC rising edge (mode A)  Audio Data Word Length 11 = 32 bits (see Note) 10 = 24 bits 01 = 20 bits 00 = 16 bits
1:0	FORMAT[1:0]	10	Audio Data Format Select 11 = DSP Mode 10 = I <sup>2</sup> S Format 01 = Left justified 00 = Right justified	

Table 11 Audio Data Format Control

### Notes:

1. Right Justified mode does not support 32-bit data.

## MASTER CLOCK AND AUDIO SAMPLE RATES

The WM8602 supports a wide range of master clock frequencies on the MCLK pin, and can generate many commonly used audio sample rates directly from the master clock. (See Table 14 for details.)

REGISTER ADDRESS	BIT	LABEL	DEFAULT	DESCRIPTION
R0 (00h) Clocking	0	CMAST	1	Master Clock Mode 0 = MCLK input 1 = XIN input
	1	MPEG	1	MPEG Mode 0 = see Table 14 1 = MCLK is 27MHz
	2	MEDGE	0	Master Clock Active Edge 0 = positive edge 1 = negative edge
	3	CLKDIV2	0	Master Clock Divide by 2 1 = MCLK is divided by 2 0 = MCLK is not divided

**Table 12 Clocking and Sample Rate Control (1)**

If the WM8602 is running in MPEG mode (i.e.  $f_{XIN} = 27\text{MHz}$ ) the sample can be detected automatically if the SRDET bit is set. In this case, the SR bits do not need programming.

REGISTER ADDRESS	BIT	LABEL	DEFAULT	DESCRIPTION
R1 (01h) Sample Rate	3:0	SR [3:0]	0000	Sample Rate Control. Refer to Table 14.
	4	SRDET	1	Sample rate detect 1 = Enabled (in MPEG mode only) 0 = Disabled

**Table 13 Clocking and Sample Rate Control (2)**

The clocking of the WM8602 is controlled using the CLKDIV2 and SR control bits. Setting the CLKDIV2 bit divides MCLK by two internally. Each value of SR[3:0] selects one combination of MCLK division ratios and hence one combination of sample rates (see next page). Since all sample rates are generated by dividing MCLK, their accuracy depends on the accuracy of MCLK. If MCLK changes the sample rates change proportionally.

MCLK / XIN		AUDIO SAMPLE RATE		SR [3:0]
(MPEG = 0)				
CLKDIV2=0	CLKDIV2=1			
[MHz]	[MHz]	[kHz]		
12.288	24.576	32	(MCLK/384)	0001
		48	(MCLK/256)	0000
24.576	49.152	96	(MCLK/256)	0011
		192	(MCLK/128)	0010
11.2896	22.5792	44.1	(MCLK/256)	0100
22.5792	45.1584	88.2	(MCLK/256)	0111
		176.4	(MCLK/128)	0110
18.432	36.864	32	(MCLK/512)	1001
		48	(MCLK/384)	1000
36.864	not supported	96	(MCLK/384)	1011
		192	(MCLK/192)	1010
16.9344	33.8688	44.1	(MCLK/384)	1100
33.8688	not supported	88.2	(MCLK/384)	1111
		176.4	(MCLK/192)	1110
(MPEG = 1)				
27.000	not supported	32		0001
		44.1		0100
		48		0000
		88.2		0111
		96		0011
		176.4		0110
		192		0010

Table 14 Master Clock and Sample Rates

The following Figure 14, Figure 15, Figure 16 and Figure 17 illustrate the different Clocking and Audio IF modes.

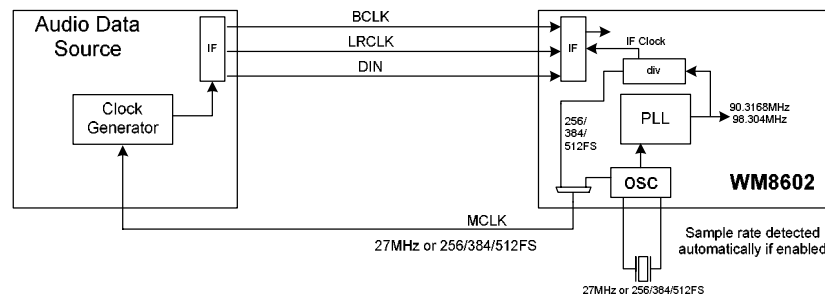

Figure 14 Clock and Audio IF: Clock Master / Audio IF Slave (Default)

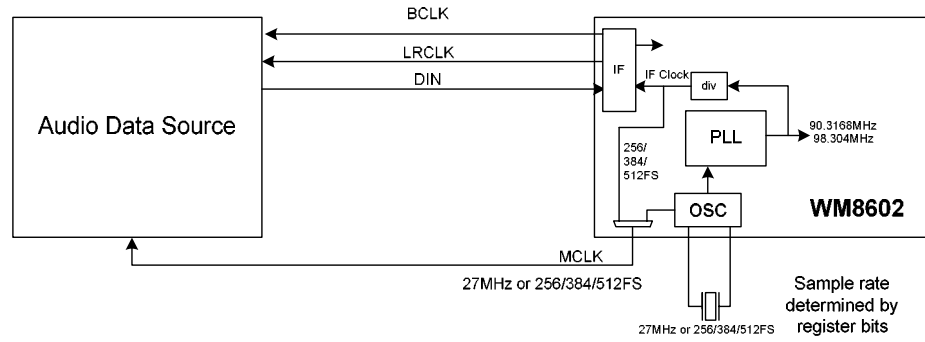

Figure 15 Clock and Audio IF: Clock Master / Audio IF Master

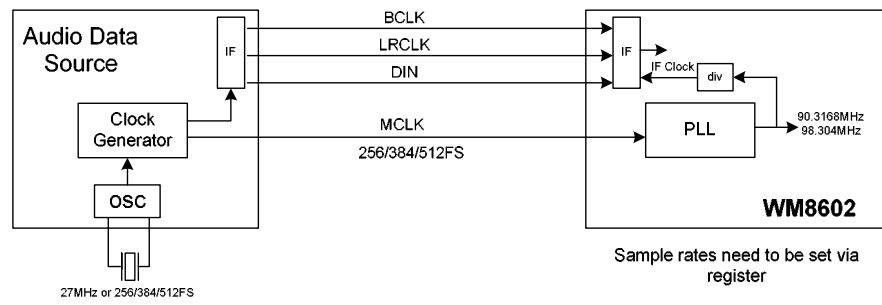

Figure 16 Clock and Audio IF: Clock Slave / Audio IF Slave

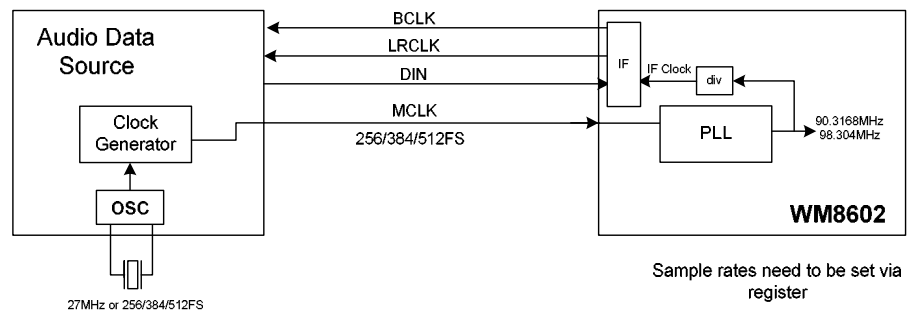

Figure 17 Clock and Audio IF: Clock Slave / Audio IF Master

## SYNCHRONISER

The WM8602 contains a synchroniser circuit to support the synchronisation of an external LRCLK to the local LRCLK. This mode is only supported in MPEG mode.

The specification of the synchroniser circuit is:

### Test Conditions

AVDD, DVDD, BVDD = 3.3V, AGND, DGND, BGND = 0V,  $T_A = +25^\circ\text{C}$ ,  $f_{\text{XIN}} = 27\text{MHz}$ , Slave Mode,  $f_s = 48\text{kHz}$ , 24-bit data, unless otherwise stated.

PARAMETER	SYMBOL	MIN	TYP	MAX	UNIT
Lock time	$t_{\text{lock}}$		<1	2	s
LRCLK frequency offset	$f_{\text{offLRCLK}}$		$\pm 1000$	$\pm 10'000$	ppm $f_s$
LRCLK drift in Lock	$\text{drift}_{\text{LRCLK}}$			0.2	ppm/s
				6	Hz

Table 15 Synchroniser Specification

REGISTER ADDRESS	BIT	LABEL	DEFAULT	DESCRIPTION
R32 (20h) Synchroniser (1)	0	SYNCEN	1	Synchroniser Enable 0: Disable 1: Enable (in MPEG mode only)
	2:1	GMIN[1:0]	10	Minimum Synchroniser Gain 00: minimum gain = $2^0$ 01: minimum gain = $2^1$ 10: minimum gain = $2^2$ 11: minimum gain = $2^3$
	4:3	GMAX[1:0]	10	Maximum Synchroniser Gain 00: maximum gain = $2^8$ 01: maximum gain = $2^{10}$ 10: maximum gain = $2^{12}$ 11: maximum gain = $2^{14}$
	5	HOLD	0	Hold Synchroniser (and SR detect) 1 : Synchroniser in hold mode

Table 16 Synchroniser (1)

REGISTER ADDRESS	BIT	LABEL	DEFAULT	DESCRIPTION
R33 (21h) Synchroniser (2)	2:0	SYNTO[2:0]	100	Synchroniser Gain time-out 000: 0.2 ms 001: 0.5 ms 010: 1 ms 011: 2 ms 100: 5 ms (default) 101: 10 ms 110: 20 ms 111: 50 ms

Table 17 Synchroniser (2)

The next table illustrates recommendation for the Synchroniser loop gain G (see also Table 16) and time-out time (Table 17) with respect to the LRCLK frequency and the resulting Synchroniser lock time.

F <sub>OFFLRCLK</sub> [ppm]	G		GAIN TIME-OUT [ms]
	max	min	
±100	2 <sup>8</sup>	2 <sup>0</sup>	~1
±1000	2 <sup>10</sup>	2 <sup>0</sup>	~4
±10'000	2 <sup>10</sup>	2 <sup>0</sup>	~20

Table 18 Synchroniser Setup and Locking

**Note:** The Synchroniser requires a continuously running LRCLK. If that is not the case the HOLD signal has to be applied to avoid the synchronizer drifting.

## CONTROL INTERFACE OPERATION

### SELECTION OF CONTROL MODE

The WM8602 is controlled by writing to registers through a serial control interface. A control word consists of 16 bits. The first 7 bits (B15 to B9) are address bits that select which control register is accessed. The remaining 9 bits (B8 to B0) are register bits, corresponding to the 9 bits in each control register. The control interface can operate as either a 3-wire or 2-wire MPU interface. The MODE pin selects the interface format. An internal pull-down resistor configures the Control Interface to a default 2 wire format.

MODE	INTERFACE FORMAT
Low	2 wire (default)
High	3 wire

Table 19 Control Interface Mode Selection

The WM8602 Control Interface operates as a slave device only.

### 3-WIRE (SPI COMPATIBLE) SERIAL CONTROL MODE

The WM8602 is controlled using a 3-wire serial interface. SDIN is used for the program data, SCLK is used to clock in the program data and CSB is used to latch in the program data. The 3-wire interface protocol is shown in Figure 13.

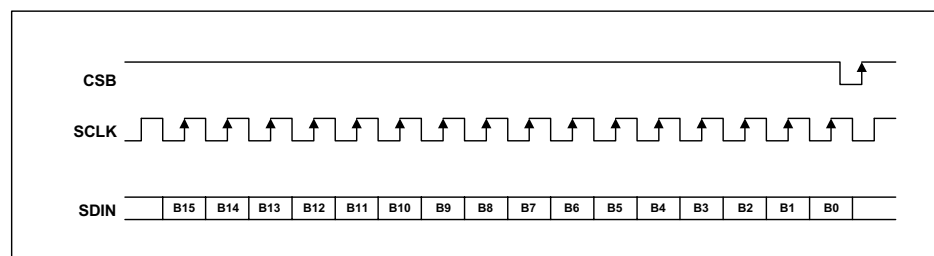

Figure 18 3-wire Serial Interface

The bits B[15:9] are Control Address Bits and the bits B[8:0] are Control Data Bits

### 2-WIRE SERIAL CONTROL MODE

The WM8602 supports software control via a 2-wire serial bus. Many devices can be controlled by the same bus, and each device has a unique 7-bit address (this is not the same as the 7-bit address of each register in the WM8602).

The controller indicates the start of data transfer with a high to low transition on SDIN while SCLK remains high. This indicates that a device address and data will follow. All devices on the 2-wire bus respond to the start condition and shift in the next eight bits on SDIN (7-bit address + Read/Write bit, MSB first). If the device address received matches the address of the WM8602 and the R/W bit is '0', indicating a write, then the WM8602 responds by pulling SDIN low on the next clock pulse (ACK). If the address is not recognised or the R/W bit is '1', the WM8602 returns to the idle condition and wait for a new start condition and valid address.

Once the WM8602 has acknowledged a correct address, the controller sends the first byte of control data (B15 to B8, i.e. the WM8602 register address plus the first bit of register data). The WM8602 then acknowledges the first data byte by pulling SDIN low for one clock pulse. The controller then sends the second byte of control data (B7 to B0, i.e. the remaining 8 bits of register data), and the WM8602 acknowledges again by pulling SDIN low.

The transfer of data is complete when there is a low to high transition on SDIN while SCLK is high. After receiving a complete address and data sequence the WM8602 returns to the idle state and waits for another start condition. If a start or stop condition is detected out of sequence at any point during data transfer (i.e. SDIN changes while SCLK is high), the device jumps to the idle condition.

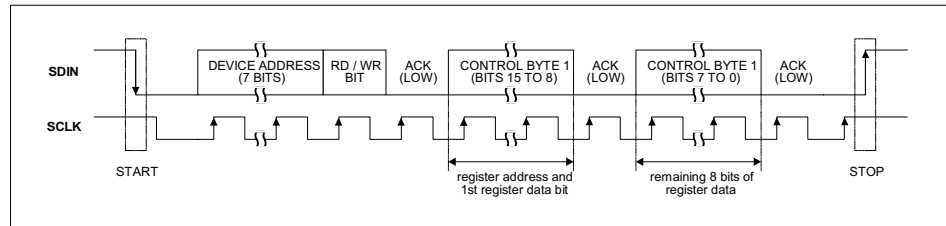

Figure 18 2-Wire Serial Control Interface

The WM8602 has two possible device addresses, which can be selected using the CSB pin.

CSB STATE	DEVICE ADDRESS
Low	0011010
High	0011011

Table 20 2-Wire MPU Interface Address Selection

## INPUT PROCESSOR

The WM8602 supports the production of stereo or 2.1 outputs from stereo inputs according to Table 21.

OUTPUT CONFIGURATIONS			
CONFIG	FL OUT	FR OUT	SUB OUT
Stereo	●	●	
2.1	●	●	●

Table 21 Output Configuration



REGISTER ADDRESS	BIT	LABEL	DEFAULT	DESCRIPTION
R3 (03h) Input/Output Configuration	3	OPCFG[1:0]	1	Output Configuration 0 = Stereo 1 = 2.1

**Table 22 Input and Output Configuration Register**

The WM8602 also supports Stereo input – Stereo output via the Bass Management filtering options, as discussed in **Bass Management** (page 25). In this case, the output configuration is set to 2.1.

Where there are a different number of input and output channels, the data is processed as follows. Refer to the section on **Bass Management** (page 25) for details on how the sub-channel is created.

#### STEREO INPUT – STEREO OUTPUT

The Left and Right inputs are passed to the Left and Right Outputs. All other channels are muted.

#### STEREO INPUT – 2.1 OUTPUT

The Left and Right inputs are passed to the Left and Right outputs. The low-frequency contents of the Left and Right inputs, may be optionally mixed and passed to the SUB output.

## BASS MANAGEMENT

The Bass-Management function filters and combines the input signals to produce a low-pass filtered output for the sub-woofer channel and high-pass filtered outputs for the remaining channels. The filters have selectable cut-off frequencies to match different types of sub-woofer and satellite speakers. The filters are designed so that the cut-off frequencies for the high-pass and low-pass filters remain constant irrespective of the sampling frequency used. 1<sup>st</sup> order filters are used for the low-pass and high-pass filters.

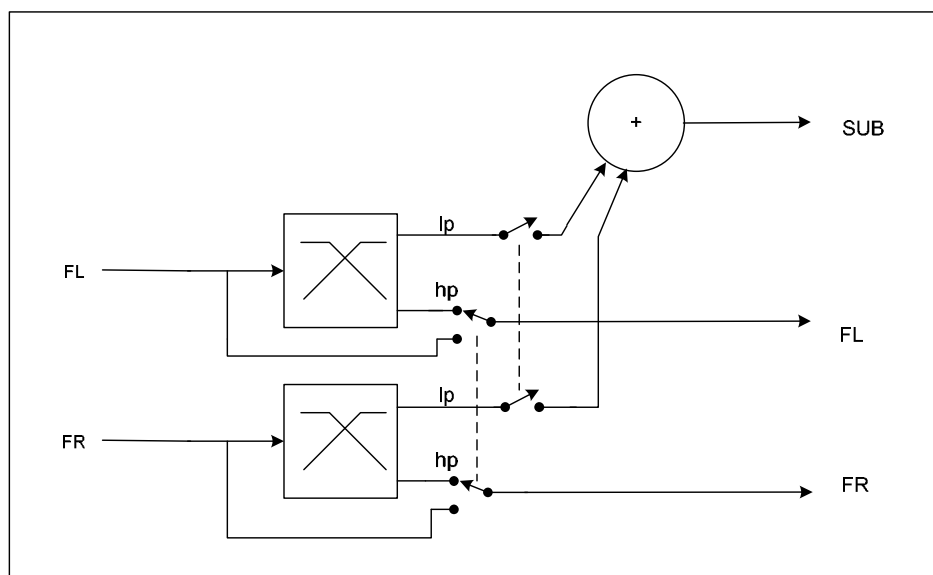

**Figure 19 Bass Management**

The high-pass filters pairs can be bypassed to allow full-range speakers to be used on the main output pair.

The Bass-Management also provides a selectable LFE boost of 10dB via the LFEBOOST control bit.

Additional gain-adjust is provided after this block (refer to Digital Volume Control, page 28).

REGISTER ADDRESS	BIT	LABEL	DEFAULT	DESCRIPTION
R13 (0Dh) Bass Management Filter	1:0	LPHPCO[1:0]	01	Low-/High-Pass Cutoff Frequency (-3dB) 00 = 75Hz 01 = 100Hz 10 = 133Hz 11 = 178Hz
	2	LFEBOOST	0	LFE Boost Enable 0 = Boost Disabled 1 = 10dB Boost Enabled

Table 23 Bass Management Filter

REGISTER ADDRESS	BIT	LABEL	DEFAULT	DESCRIPTION
R14 (0Eh) Bass Management Filter Bypass	0	HPENF	1	Left/Right High-Pass Filter 0 = High-Pass Filter bypassed 1 = High-Pass Filter enabled
	3	LPENF	1	Left/Right Low-Pass Filter Enable 0 = Low-Pass Filter output disabled 1 = Low-Pass Filter output enabled

Table 24 Bass Management Filter Bypass

## GRAPHIC EQUALISER

The WM8602 has a 4-band Graphic Equaliser on the main channels. The three upper bands are controlled via registers (see Table 25, Table 26, Table 27 and Table 28). The lowest band is controlled via the subwoofer volume control (see VOLS in Table 31). The function has selectable cut-off frequencies which are independent of sample rate. The boost/cut for the upper three bands is controllable in 1.5dB steps from -6dB to +9dB via the EQB control bits.

REGISTER ADDRESS	BIT	LABEL	DEFAULT	DESCRIPTION
R15 (0Fh) EQ Band 1 Gain Control	3:0	EQ1GF [3:0]	1111 (Disabled)	Band 1 Left/Right Gain 0000 or 0001 = +9dB 0010 = +7.5dB ... (1.5dB steps) 1011 to 1110 = -6dB 1111 = Disable

Table 25 EQ Band 1 Gain Control

REGISTER ADDRESS	BIT	LABEL	DEFAULT	DESCRIPTION
R16 (10h) EQ Band 2 Gain Control	3:0	EQ2GF [3:0]	1111 (Disabled)	Band 2 Left/Right Gain 0000 or 0001 = +9dB 0010 = +7.5dB ... (1.5dB steps) 1011 to 1110 = -6dB 1111 = Disable

Table 26 EQ Band 2 Gain Control

REGISTER ADDRESS	BIT	LABEL	DEFAULT	DESCRIPTION
R17 (11h) EQ Band 3 Gain Control	3:0	EQ3GF [3:0]	1111 (Disabled)	Band 3 Left/Right Gain 0000 or 0001 = +9dB 0010 = +7.5dB ... (1.5dB steps) 1011 to 1110 = -6dB 1111 = Disable

Table 27 EQ Band 3 Gain Control

REGISTER ADDRESS	BIT	LABEL	DEFAULT	DESCRIPTION
R18 (12h) EQ Centre-Frequency Control	0	EQ1CF	1	Band 1 Left/Right Centre-Frequency 0 = High Cutoff (500Hz) 1 = Low Cutoff (250Hz)
	2	EQ2CF	1	Band 2 Left/Right Centre-Frequency 0 = High Cutoff (2kHz) 1 = Low Cutoff (1kHz)
	4	EQ3CF	1	Band 3 Left/Right Cutoff Frequency 0 = High Cutoff (8kHz) 1 = Low Cutoff (4kHz)

Table 28 EQ Frequency Control

Band 0 is controlled via the sub-woofer volume control register R11 as described in Table 31. The functionality to add/subtract the boost/cut setting to the sub-woofer volume must be written into the software controller for the chip.

The Band 0 Cutoff frequency can be changed using the corner frequency of the low-pass/high-pass filters as described in Table 23.

#### DIGITAL LOUDSPEAKER EQUALISER

A loudspeaker equaliser is provided to compensate for high-frequency variations that can occur when loudspeakers of different impedances are used with different output filters in typical output stages. The equaliser has selectable cut-off frequencies which are independent of sample rate. The gain at 20kHz is controllable in 0.5dB steps from -1.5dB to +2dB via the LSEQ control bit. The settings are applied to Left and Right channels simultaneously.

REGISTER ADDRESS	BIT	LABEL	DEFAULT	DESCRIPTION
R19 (13h) Loudspeaker Equaliser	0	LSCO	0	LSEQ Filter Characteristic 0 = High Cutoff (15kHz) 1 = Low Cutoff (10kHz)
	3:1	LSEQ [2:0]	100 (Disabled)	High Frequency Equalisation 000 = +2dB 001 = +1.5dB 010 = +1dB 011 = +0.5dB 100 = Disable 101 = -0.5dB 110 = -1dB 111 = -1.5dB

Table 29 Loudspeaker Equaliser

## DIGITAL DEEMPHASIS

The digital 'de-emphasis' is used to equalize pre-emphasised digital CD recordings. De-emphasis filtering is available on the Left and Right channels only, for sample rates of 32kHz, 44.1kHz and 48kHz. The settings are applied to the two channels simultaneously.

REGISTER ADDRESS	BIT	LABEL	DEFAULT	DESCRIPTION
R20 (14h) De-emphasis	0	DEEMP	0	De-emphasis Control 0 = No De-emphasis 1 = De-emphasis enabled

**Table 30 De-emphasis**

Refer to Figure 30, Figure 31, Figure 32, Figure 33, Figure 34 and Figure 35 for details of the De-Emphasis modes at different sample rates.

**Note:** Using the De-emphasis filters for other sample rates as defined above will result in a frequency response error as shown in Figure 31, Figure 33 and Figure 35.

## DIGITAL VOLUME CONTROL

The volume control allows the gain of each channel to be independently adjusted in 0.5dB steps from -103.5dB to +24dB. When the Dynamic Peak Compressor (see below) is enabled, gains of greater than 0dB can be applied without digital clipping occurring. The volume control has a digital zero-cross circuit which minimises clicks during changing the volume.

An update control bit is provided which allows the volume setting on each channel to be first stored in an intermediate latch, then afterwards applied simultaneously to all channels. If UPDATE=0, the Volume value will be written to the pre-latch but not applied to the relevant channel. If UPDATE=1, all pre-latched values will be applied from the next input sample. The value of UPDATE itself is not latched.

To prevent audible clicks, the volume control includes a ramp function which automatically ramps the volume in small steps between register updates. The ramp rate is 256dB/s  $\pm$ 5%.

REGISTER ADDRESS	BIT	LABEL	DEFAULT	DESCRIPTION
R4 (04h) Left Volume	7:0	VOLL[7:0]	10110001 (-15dB)	Left Volume in 0.5dB steps. Refer to Table 14
	8	UPDATE	0	Volume Update 0 = Store LVOL in intermediate latch (no gain change) 1 = Store and Update all channel gains
R5 (05h) Right Volume	7:0	VOLR [7:0]	10110001 (-15dB)	Right Volume in 0.5dB steps. Refer to Table 14
	8	UPDATE	0	Volume Update 0 = Store RVOL in intermediate latch (no gain change) 1 = Store and Update all channel gains
R10 (0Ah) Subwoofer Volume	7:0	VOLS [7:0]	10110001 (-15dB)	Sub Volume in 0.5dB steps. Refer to Table 14
	8	UPDATE	0	UPDATE 0 = Store SVOL in intermediate latch (no gain change) 1 = Store and Update all channel gains

**Table 31 Volume Control**

VOLXX[7:0]	VOLUME LEVEL
00(hex)	-∞dB (mute)
01(hex)	-103dB
:	:
:	:
CF(hex)	0dB
:	:
:	:
FE(hex)	+23.5dB
FF(hex)	+24dB

Table 32 Volume Control Levels

### DUAL VOLUME CONTROL

Setting the DVC register bit causes the volume settings to be applied in pairs. For example, the DVCF causes the Left channel volume settings to be applied to both the Left and Right channels from the next audio input sample. No update to the VOL registers is required for DVC to take effect.

REGISTER ADDRESS	BIT	LABEL	DEFAULT	DESCRIPTION
R11 (0Bh) Dual Volume Control	0	DVCF	0	Dual Volume Control – Left/Right Channels: 0 : Use VOLFR setting for Right channel 1: Apply VOLFL setting to Right channel

Table 33 Dual Volume Control

### SOFT MUTE AND AUTO-MUTE

The WM8602 has a Soft Mute function set by the SMUTE control bit. Figure 20 shows the application and release of SMUTE while a full amplitude sinusoid is being played at 48kHz sampling rate. When SMUTE (lower trace) is asserted, the output (upper trace) begins to decay exponentially from the DC level of the last input sample. The output will decay towards zero with a time constant of approximately 64 input samples. When SMUTE is turned off, the output will restart almost immediately from the current input sample, thus possibly causing a pop sound.

This function is disabled by default.

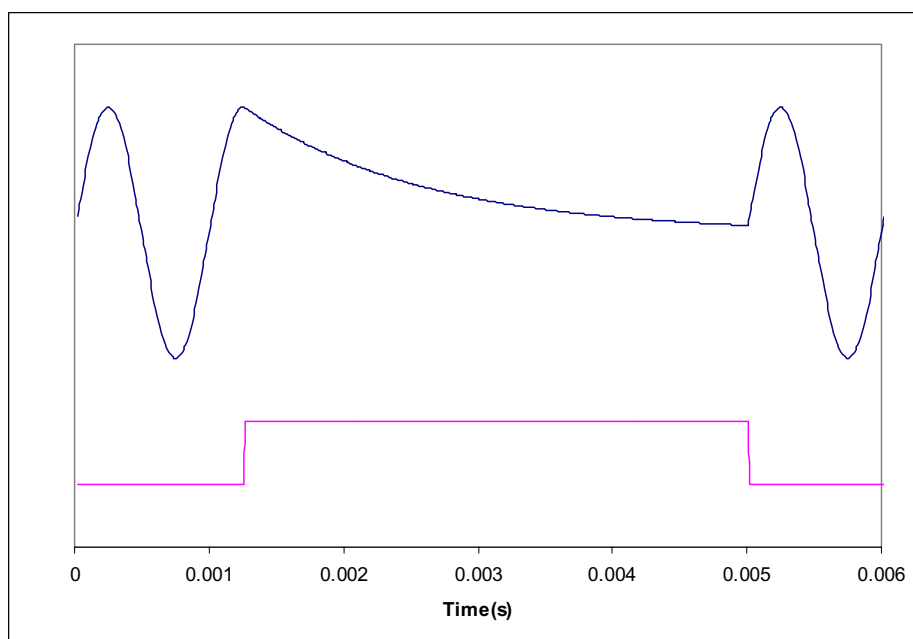

**Figure 20 Application and Release of Soft Mute**

An auto-mute function is provided which automatically mutes the output stage when a digital silence period is detected. Digital silence is defined as a consecutive period of 1024 zero input samples at the output of the volume control. Auto-mute will be removed as soon as the volume control output becomes non-zero. (Please note that on the sub channel the noise level is greatly reduced, rather than complete digital silence.)

To achieve digital silence, you can do one of the following:

- Turn on auto-mute and set the volume control to zero.
- Turn on auto-mute and input zero data on the serial data input pins with the bass management filters disabled. (Page 25)
- Turn on auto-mute and soft mute.

The auto-mute operates independently for Left/Right and Subwoofer channels and can be enabled or disabled separately.

The mute features maximize the SNR of the PWM amplifier system. Soft-mute will only maximize the SNR for Left/Right or Subwoofer channels if enabled.

REGISTER ADDRESS	BIT	LABEL	DEFAULT	DESCRIPTION
R12 (0Ch) Mute	0	SMUTE	0	Digital Soft Mute 0 = disable (signal active) 1 = enable
	1	AMUTEF	1	Left/Right Auto-mute 0 = disable 1 = enable
	4	AMUTESB	1	Subwoofer Auto-mute 0 = disable 1 = enable

**Table 34 Mute**

## DYNAMIC PEAK COMPRESSOR

The WM8602 includes a Dynamic Peak Compressor for each channel, which prevents the occurrence of digital clipping when gains in excess of 0dB are applied. The compressor automatically adjusts the signal amplitude to allow headroom for the LFE boost, sub-woofer mixing, tone controls, loudspeaker equalisation and digital volume control. The compressor has a programmable limit threshold, programmable attack and decay time-constants, a frequency-dependent decay mode, and built-in zero-cross detect. The compressor can be configured either to operate independently on all channels (DUAL MONO), or on linked channel-pairs (STEREO).

### COMPRESSOR THRESHOLD

The compressor has a digital peak detector which tracks the maximum input signal level at the output of the volume control. With reference to Figure 21, if this signal is below the threshold set by control bit THRESH, the compressor operates transparently with no change to the signal level. However, if peak signal rises above the threshold, the gain through the compressor is modified so that the upper part of the curve is followed. This ensures that the output signal does not exceed 0dB.

### ATTACK AND DECAY TIMES

The **attack time-constant** ATK controls how fast the gain is reduced when the signal goes above the threshold. It is defined as the time taken for the gain to reduce by 6dB. Normally a short attack time-constant is used to prevent the signal clipping when a high-amplitude transient occurs.

The **decay time-constant** DCY controls how fast the gain is increased when the signal begins to fall again. It is defined as the time taken for the gain to increase by 6dB. Normally, the decay time-constant is much longer than the attack time-constant, to prevent the input signal from entering repeated limiting cycles.

The **frequency-dependent decay** feature automatically detects the input frequency and sets the decay time to decay slower for low frequency signals. This reduces low-frequency signal distortion by preserving the waveform of each input cycle, whilst allowing the compressor to respond quickly to high frequency transients. This feature is enabled via the FDEP control bit.

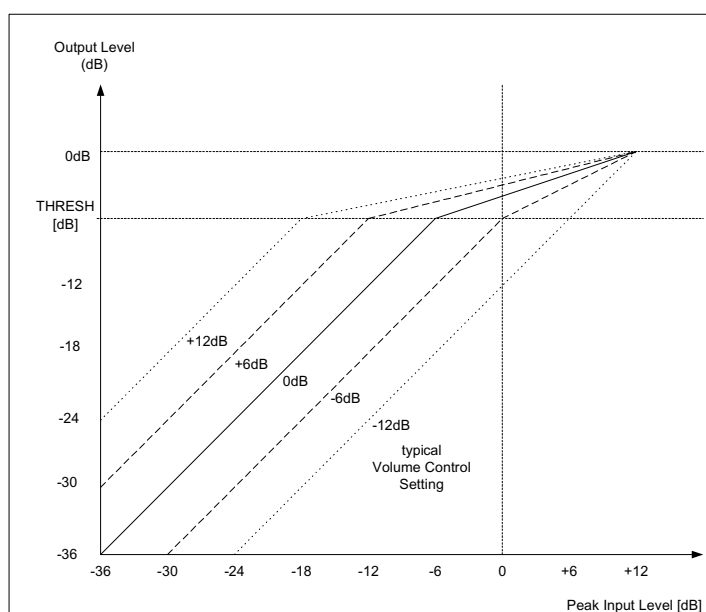

Figure 21 Dynamic Peak Compressor Characteristics

REGISTER ADDRESS	BIT	LABEL	DEFAULT	DESCRIPTION
R21 (15h) Left/Right Channels Dynamic Peak Compressor	0	PLENF	1	Left/Right Channel Compressor Enable 0 = disable 1 = enable

Table 35 Left/Right Channel Dynamic Peak Compressor (1)

REGISTER ADDRESS	BIT	LABEL	DEFAULT	DESCRIPTION
R22 (16h) Left/Right Channels Dynamic Peak Compressor	2:0	ATK[2:0]	010	Left/Right Channel Attack Rate 000 = 170µs 001 = 330µs 010 = 670µs 011 = 1.33ms 100 = 2.67ms 101 = 5.33ms 110 = 10.7ms 111 = 20.1ms
	5:3	DCY[2:0]	011	Left/Right Channel Decay Rate 000 = 340ms 001 = 680ms 010 = 1.36s 011 = 2.73s 100 = 5.46s 101, 110, 111 = 10.9s
	7:6	THRESH[1:0]	11	Left/Right Channel Compressor Thresholds 00 = -12dB 01 = -9dB 10 = -6dB 11 = -3dB
	8	FDEP	0	Frequency-dependent decay 0 = disable 1 = enable

Table 36 Left/Right Channel Dynamic Peak Compressor (2)

REGISTER ADDRESS	BIT	LABEL	DEFAULT	DESCRIPTION
R23 (17h) Sub Channel Dynamic Peak Compressor	0	PLENSUB	1	Sub Channel Compressor Enable 0 = disable 1 = enable

Table 37 Subwoofer Channel Dynamic Peak Compressor (1)



REGISTER ADDRESS	BIT	LABEL	DEFAULT	DESCRIPTION
R24 (18h) Sub Channel Dynamic Peak Compressor	2:0	ATK[2:0]	010	Sub Channel Attack Rate 000 = 170µs 001 = 330µs 010 = 670µs 011 = 1.33ms 100 = 2.67ms 101 = 5.33ms 110 = 10.7ms 111 = 20.1ms
	5:3	DCY[2:0]	011	Sub Channel Decay Rate 000 = 340ms 001 = 680ms 010 = 1.36s 011 = 2.73s 100 = 5.46s 101, 110, 111 = 10.9s
	7:6	THRESH[1:0]	11	Sub Channel Compressor Thresholds 00 = -12dB 01 = -9dB 10 = -6dB 11 = -3dB
	8	FDEP	0	Frequency-dependent decay 0 = disable 1 = enable

Table 38 Subwoofer Channel Dynamic Peak Compressor (2)

**ZERO-CROSS DETECT**

The Dynamic Peak Compressor has a zero-cross detect which minimises clicks during gain changes. The zero-cross detect can be enabled/disabled for Left/Right or Subwoofer channels. The zero-cross has a timeout feature which ensures that the volume will change even if the input has a large DC offset. Once a new gain has been requested from the Dynamic Peak Compressor, the zero-cross detector will wait for a zero-cross for 25 to 50 ms before applying the gain change.

REGISTER ADDRESS	BIT	LABEL	DEFAULT	DESCRIPTION
R25 (19h) Volume Control Zero- Cross	0	ZCF	1	Zero-Cross Enable – Left/Right Channels: 0 : Disable Zero-Cross 1: Enable Zero-Cross
	3	ZCSUB	1	Zero-Cross Enable – Sub Channel: 0 : Disable Zero-Cross 1: Enable Zero-Cross
	4	ZCT	1	Zero Cross Timeout Enable: 0 : Disable Zero-Cross Timeout 1: Enable Zero-Cross Timeout

Table 39 Volume Control Zero-Cross

## INTERPOLATION FILTERS

The WM8602 uses two types of interpolation filters, selected according to sampling frequency, as shown in Table 39.

SAMPLING FREQUENCY	FILTER TYPE	INTERPOLATION	
	Main Channels	Main Channels	SUB
32kHz	0	12x	6x
44.1kHz	0	8x	4x
48kHz	0	8x	4x
88.2kHz	0	4x	2x
96kHz	0	4x	2x
176.4kHz	1	2x	1x
192kHz	1	2x	1x

Table 40 Interpolation Filter Types

### FILTER TYPE 0

PARAMETER	SYMBOL	TEST CONDITIONS	MIN	TYP	MAX	UNIT
<b>Filter</b>						
Passband		$\pm 0.05$ dB			0.454	$f_s$
Stopband		-3dB		0.484		$f_s$
Passband ripple					$\pm 0.05$	dB
Stopband Attenuation		$f > 0.546f_s$	-60			dB
Group Delay			23			samples

Table 41 Digital Filter 0 Characteristics

### FILTER TYPE 1

PARAMETER	SYMBOL	TEST CONDITIONS	MIN	TYP	MAX	UNIT
<b>Filter</b>						
Passband					0.242	$f_s$
Stopband				0.723		$f_s$
Passband ripple					$\pm 0.05$	dB
Stopband Attenuation			-60			dB
Group Delay			6			samples

Table 42 Digital Filter 1 Characteristics

The subwoofer filter characteristic is defined in table

### FILTER TYPE SUBWOOFER

PARAMETER	SYMBOL	TEST CONDITIONS	-0.1dB	-3dB	UNIT
<b>Sample Rate</b>					
32k			2.0	10.7	kHz
44k1			2.7	14.5	kHz
48k			3.0	15.8	kHz
88k2			6.1	32.1	kHz
96k			6.8	34.9	kHz
176k			*	*	kHz
192k			*	*	kHz

Table 43 Subwoofer Filter Characteristic

**Note:** \* indicates no interpolation filters

## PCM TO PWM CONVERTER

The PCM to PWM converter converts the Pulse-Code Modulated (PCM) signal into a highly linear Pulse-Width Modulated (PWM) signal. Table 44 defines the Pulse Repetition Frequency, (PRF), output clock rate (OBCLK) and minimum pulse width for each supported sampling frequency.

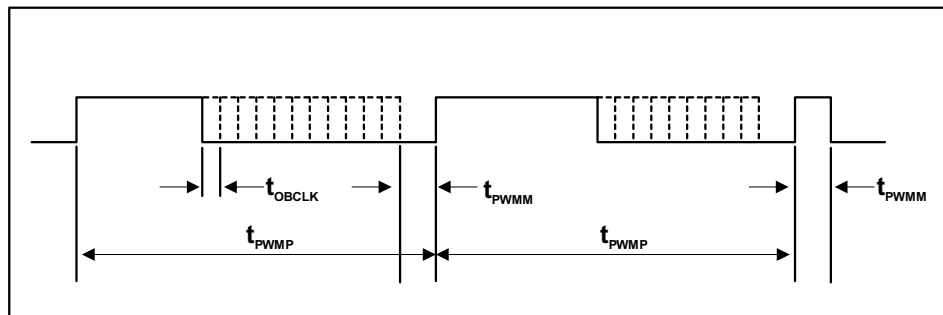

Figure 22 PCM to PWM Converter

The PRF Frequency ( $T_{PWMP}$ ) of the Sub-woofer channel is half of the frequency defined in Table 44 in order to reduce power dissipation in the output stage.

SAMPLING FREQUENCY	PRF ( $1/T_{PWMP}$ )		OUTPUT BITCLOCK FREQUENCY ( $1/T_{OBCLK}$ )	MINIMUM PULSE WIDTH ( $T_{PWMM}$ )
	Main Channel	SUB		
	[kHz]	[kHz]		
32kHz	384	192	98.304	122
44.1kHz	352.8	176.4	90.3168	133
48kHz	384	192	98.304	122
88.2kHz	352.8	176.4	90.3168	133
96kHz	384	192	98.304	122
176.4kHz	352.8	176.4	90.3168	133
192kHz	384	192	98.304	122

Table 44 Output Bitclock Frequency

### Notes:

- The correct Output Bitclock Frequency ( $T_{OBCLK}$ ) is generated by the built-in PLL of the WM8602 device. The incoming clock must meet the jitter specification defined in Table 3.

## OUTPUT PHASE

The Phase control word determines whether the output of each channel is non-inverted or inverted.

REGISTER ADDRESS	BIT	LABEL	DEFAULT	DESCRIPTION		
R26 (1Ah) Output Phase	6:0	PH[6:0]	0000000	Bit	Channel	Phase
				0	L	1 = invert
				1	R	1 = invert
				6	SUB	1 = invert

Table 45 Phase

## PWM OUTPUT CONFIGURATION

The PWM output format can be defined with the PWMCFG setting defined in Table 46.

REGISTER ADDRESS	BIT	LABEL	DEFAULT	DESCRIPTION
R27 (1Bh) PWM Output Configuration	2:1	PWMCFG [1:0]	00	PWM Output State when output disabled or in standby mode: 01 = all PWM Outputs high 00 = all PWM Outputs low 10, 11 = high impedance
	3	PWMPH	1	PWM Output Phase 0 = PWM outputs in phase 1 = PWM outputs phase shifted to each other
	7	PWMCLK	0	PWM Output Clock 0 = disabled 1 = enabled

Table 46 PWM Output Configuration

## OUTPUT CONFIGURATION

If required the WM8602 device can be disabled in a system by setting the TRI bit as defined in Table 47. Setting the TRI bit will set all output pins of the device to high impedance.

REGISTER ADDRESS	BIT	LABEL	DEFAULT	DESCRIPTION
R28 (1Ch) Output Configuration	0	TRI	0	Output Pins Mode 0 = Normal 1 = High Impedance

Table 47 Output Configuration

## STANDBY, OUTPUT DISABLE AND RESET MODES

### STANDBY

Setting the STDBY register bit selects a low power mode, and immediately configures the output to produce an output defined in Table 46 (PWMCFG). All trace of the previous input samples is removed, but all control register settings are preserved.

### OUTPUT DISABLE (OPDIS) PIN AND REGISTER (OPDISR)

The OPDIS pin is provided to immediately shutdown the outputs, primarily for their protection. This is useful for short-circuit or thermal protection. The OPDIS pin can be configured in 2 modes:

- Synchronous
- Latched

In *synchronous* mode if OPDIS is high for longer than 100ns the outputs will be disabled. They will be enabled again at the end of a processing frame when OPDIS goes low for longer than 100ns.

In *latched* mode if OPDIS is high for longer than 100ns, the outputs will be disabled and will remain off until OPDIS is reset via the control interface and the end of a processing frame is reached (Table 49).

The output disable register (OPDISR) also allows the PWM outputs to be disabled via a register write. If OPDISR is set the PWM outputs will be disabled at the end of the next processing frame and enabled if OPDISR is reset at the end of the next processing frame.

REGISTER ADDRESS	BIT	LABEL	DEFAULT	DESCRIPTION
R29 (1Dh) Power Down	0	STDBY	1	Standby select: 0 : Normal Mode 1: Standby Mode
	1	OPDISR	0	Output disable register 0: Normal mode 1: PWM output disabled
	2	MENA	1	OPDIS Mode 0 : Synchronous 1: Latched, reset via Control I/F

Table 48 Power Down

### EXTERNAL APPLICATION POWER-DOWN (EAPDB) PIN

The state of the output pin EAPDB shows whether the device is disabled (i.e. OPDIS input pin active or STDBY register set).

EAPDB	STATE	DESCRIPTION
External Application Power Down	1	The device is operating correctly
	0 (default)	The outputs are disabled or the WM8602 device is in Standby (default) mode

Table 49 EAPDB Pin

### RESET

The WM8602 device can be reset writing to the Reset register as defined in Table 50.

REGISTER ADDRESS	BIT	LABEL	DEFAULT	DESCRIPTION
R30 (1Eh) Reset	0	RLENA	0	Writing 1 to bit 0 of the register will reset OPDIS
	all	RESET	0	Writing all 1's to the register will reset the device and register settings

Table 50 Reset

**Note:** RESET or RLENA will be applied at the end of the register write and released at the beginning of the next register write. I.e. to reset the OPDIS register write 1 to bit 0 of the Reset register and then write 0 to bit 0.

### EXTERNAL POWER SUPPLY CLOCK

The WM8602 device can generate a clock signal for an external PSU (Power Supply Unit) which is available at the CLKPSU pin.

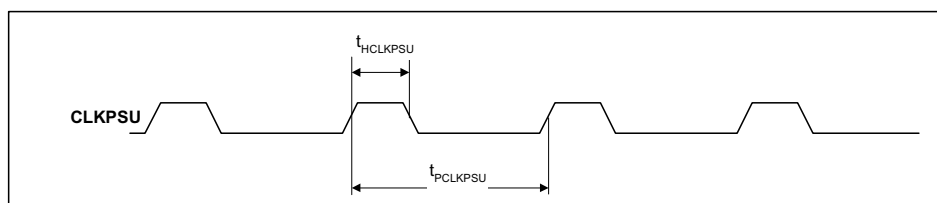

Figure 23 External Power Supply Clock

REGISTER ADDRESS	BIT	LABEL	DEFAULT	DESCRIPTION
R31 (1Fh) PSU	0	ENPSU	0	CLKPSU enable 1: enabled
	2:1	CLKPSU[1:0]	00	CLKPSU frequency 00: CLKPSU = $f_{PRF}$ 01: CLKPSU = $f_{PRF}/2$ 10: CLKPSU = $f_{PRF}/4$ 11: CLKPSU = $f_{PRF}/6$
	4:3	DCYPSU[1:0]	00	CLKPSU duty cycle 00: $t_{hclkpsu}/t_{pclkpsu} = 0.5$ (50%) 01: $t_{hclkpsu}/t_{pclkpsu} = 0.125$ (12.5%) 10: $t_{hclkpsu}/t_{pclkpsu} = 0.0625$ (6.25%) 11: $t_{hclkpsu}/t_{pclkpsu} = 0.03125$ (3.125%)

Table 51 PSU Clock

**Note:** See Table 44 for specification of  $f_{PRF}$ .

## REGISTER MAP

The complete register map is shown below. The detailed description can be found in the relevant text of the device description. There are 30 registers with 9 bits per register. These can be controlled using the Control Interface.

REGISTER	ADDRESS	REMARKS	BIT[8]	BIT[7]	BIT[6]	BIT[5]	BIT[4]	BIT[3]	BIT[2]	BIT[1]	BIT[0]	DEFAULT	PAGE REF
R0 (00h)	00_0000	Clocking	0	0	0	0	0	CLKDIV2	MEDGE	MPEG	CMASST	0_0000_0011	19
R1 (01h)	00_0001	Sample Rate	0	0	0	0	SRDET	SR				0_0001_0000	19
R2 (02h)	00_0010	Audio IF Format	BCLKINV	MS	LRSWAP	0	LRP	WL		FORMAT		0_0000_1010	18
R3 (03h)	00_0011	Input/Output Configuration	0	0	0	0	1	OPCFG	0	0	1	0_0001_1001	25
R4 (04h)	00_0100	Left Volume	UPDATE	VOLFL (Left) Volume								0_1011_0001	28
R5 (05h)	00_0101	Right Volume	UPDATE	VOLFR (Right) Volume								0_1011_0001	28
R10 (0Ah)	00_1010	Subwoofer Volume	UPDATE	VOLS (Subwoofer) Volume								0_1011_0001	28
R11 (0Bh)	00_1011	Dual Volume Control	0	0	0	0	0	0	0	0	DVCF	0_0000_0000	29
R12 (0Ch)	00_1100	Mute	0	0	0	0	AMUTESB	1	1	AMUTEF	SMUTE	0_0001_1110	30
R13 (0Dh)	00_1101	Bass (1)	0	0	0	0	0	LFEBOOST	LPHPCO			0_0000_0001	26
R14 (0Eh)	00_1110	Bass (2)	0	0	0	1	1	LPENF	1	1	HPENF	0_0011_1111	26
R15 (0Fh)	00_1111	EQ Band 1 Gain Control	0	1	1	1	1	EQ1GF				0_1111_1111	26
R16 (10h)	01_0000	EQ Band 2 Gain Control	0	1	1	1	1	EQ2GF				0_1111_1111	26
R17 (11h)	01_0001	EQ Band 3 Gain Control	0	1	1	1	1	EQ3GF				0_1111_1111	27
R18 (12h)	01_0010	EQ Frequency Control	0	0	0	1	EQ3CF	1	EQ2CF	1	EQ1CF	0_0011_1111	27
R19 (13h)	01_0011	Speaker Equaliser	0	0	0	0	0	LSEQ		LSCO		0_0000_1000	27
R20 (14h)	01_0100	Deemphasis	0	0	0	0	0	0	0	0	DEEMPH	0_0000_0000	28
R21 (15h)	01_0101	Peak Compressor F (1)	0	0	0	0	0	0	0	0	PLENF	0_0000_0001	32
R22 (16h)	01_0110	Peak Compressor F (2)	FDEP	THRESH		DCY			ATK			0_1101_1010	32
R23 (17h)	01_0111	Peak Compressor SUB (1)	0	0	0	0	0	0	0	0	PLENSUB	0_0000_0001	32
R24 (18h)	01_1000	Peak Compressor SUB (2)	FDEP	THRESH		DCY			ATK			0_1101_1010	33
R25 (19h)	01_1001	Zero Cross	0	0	0	0	ZCT	ZCSUB	1	1	ZCF	0_0001_1111	33
R26 (1Ah)	01_1010	Output phase	0	0	PH							0_0000_0000	35
R27 (1Bh)	01_1011	PWM Output Config	0	PWMCLK	0	0	0	PWMPH	PWMCFG		0	0_0000_1000	36
R28 (1Ch)	01_1100	Output Config	0	0	0	0	0	0	0	0	TRI	0_0000_0000	36
R29 (1Dh)	01_1101	Power Down	0	0	0	0	0	0	MENA	OPDISR	STDBY	0_0000_0101	37
R30 (1Eh)	01_1110	Reset	0	0	0	0	0	0	0	0	RLENA	0_0000_0000	37
R31 (1Fh)	01_1111	PSU	0	0	0	0	DCYPSU		CLKPSU		ENPSU	0_0000_0000	38
R32 (20h)	10_0000	Synchroniser (1)	0	0	0	HOLD	GMAX		GMIN		SYNCEN	0_0001_0101	22
R33 (21h)	10_0001	Synchroniser (2)	0	0	0	0	0	0	SYNTO			0_0000_0100	22

**Table 52 Register Map Description**

DIGITAL FILTER CHARACTERISTICS

FILTER RESPONSES

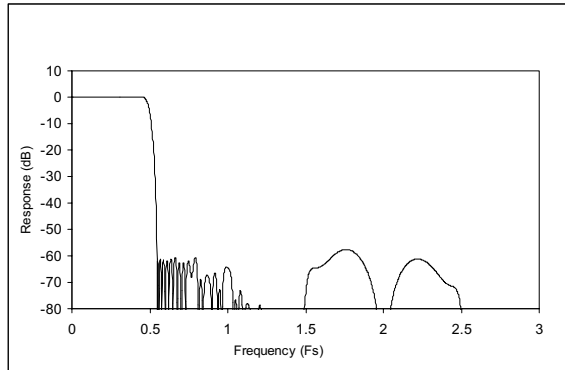

Figure 24 Digital Filter Frequency Response – 32kHz

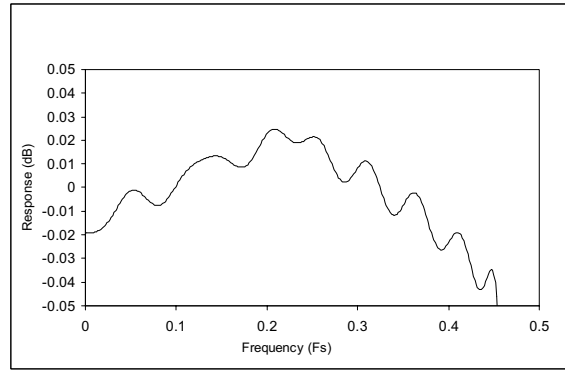

Figure 25 Digital Filter Ripple – 32kHz

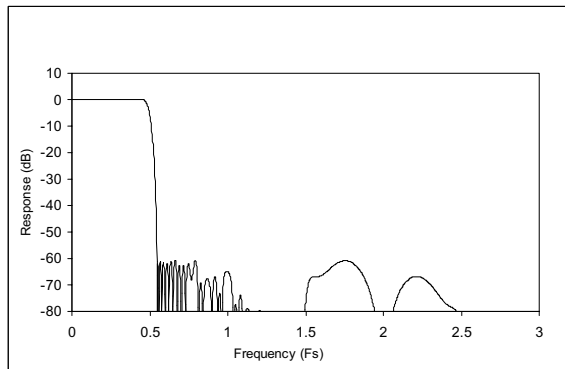

Figure 26 Digital Filter Frequency Response – 44.1, 48 and 96kHz

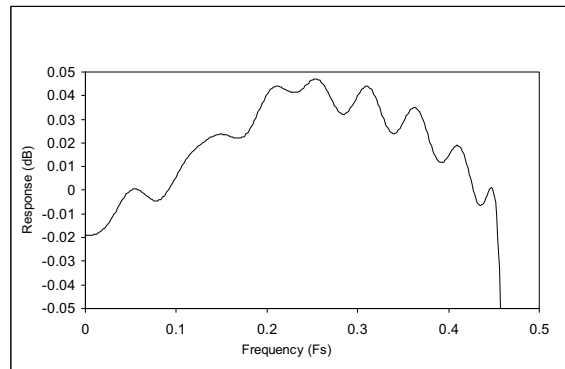

Figure 27 Digital Filter Ripple – 44.1, 48 and 96kHz

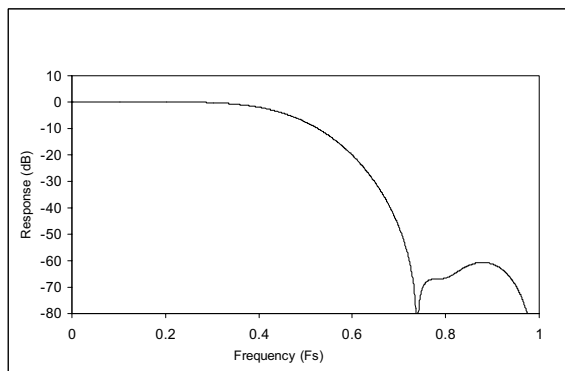

Figure 28 Digital Filter Frequency Response – 176.4kHz and 192kHz

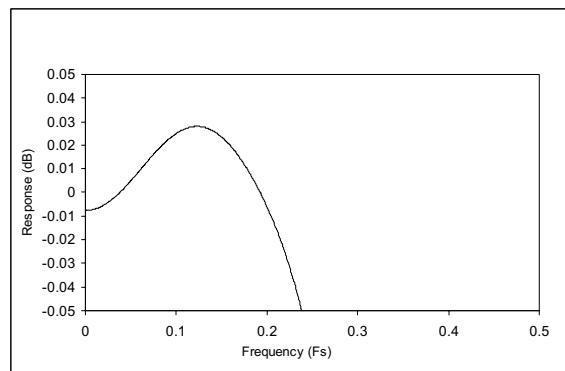
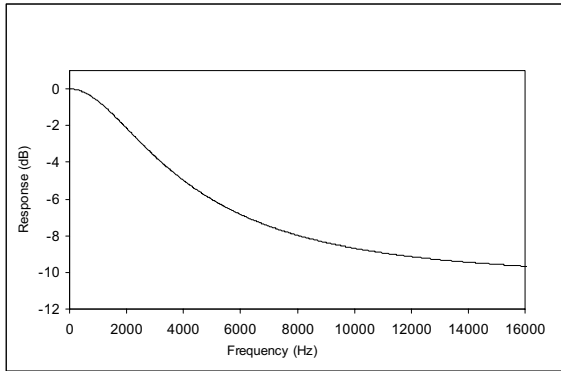

Figure 29 Digital filter Ripple – 176.4kHz and 192kHz



**DIGITAL DE-EMPHASIS CHARACTERISTICS**



**Figure 30 De-Emphasis Frequency Response (32kHz)**

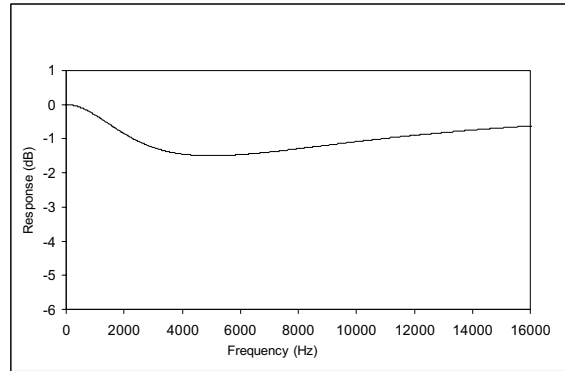

**Figure 31 De-Emphasis Error (32kHz)**

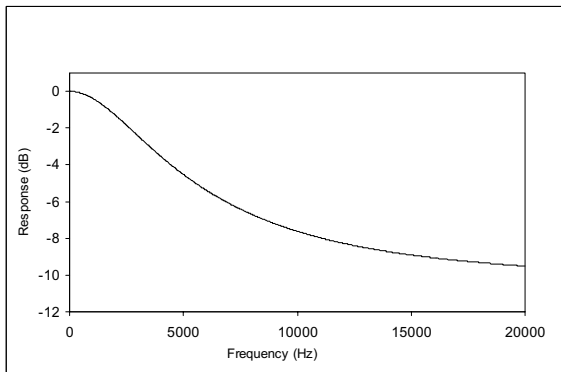

**Figure 32 De-Emphasis Frequency Response (44.1kHz)**

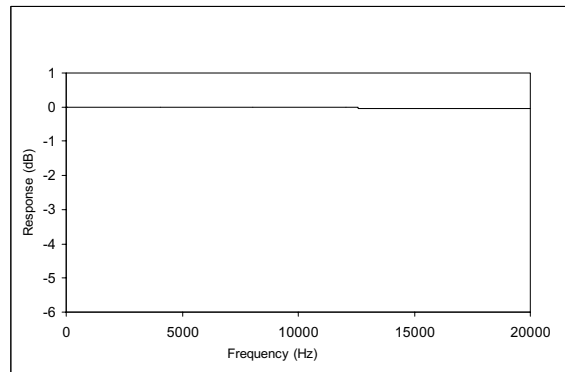

**Figure 33 De-Emphasis Error (44.1kHz)**

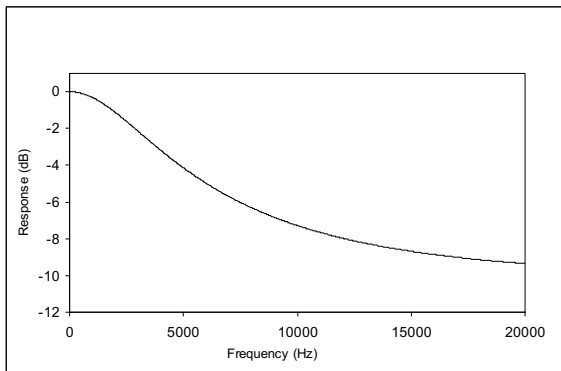

**Figure 34 De-Emphasis Frequency Response (48kHz)**

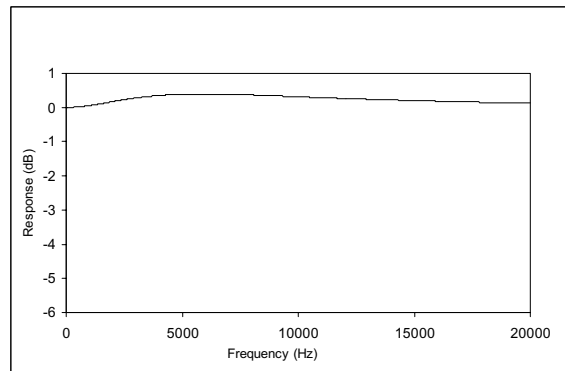

**Figure 35 De-Emphasis Error (48kHz)**

APPLICATION NOTES

START-UP

The WM8602 per default is switched off and the PWM output pins are static high, to protect any external circuit. When the device has been properly initialized and the output configuration has been defined then the device can safely be switched on. A typical start-up sequence is show in Figure 36.

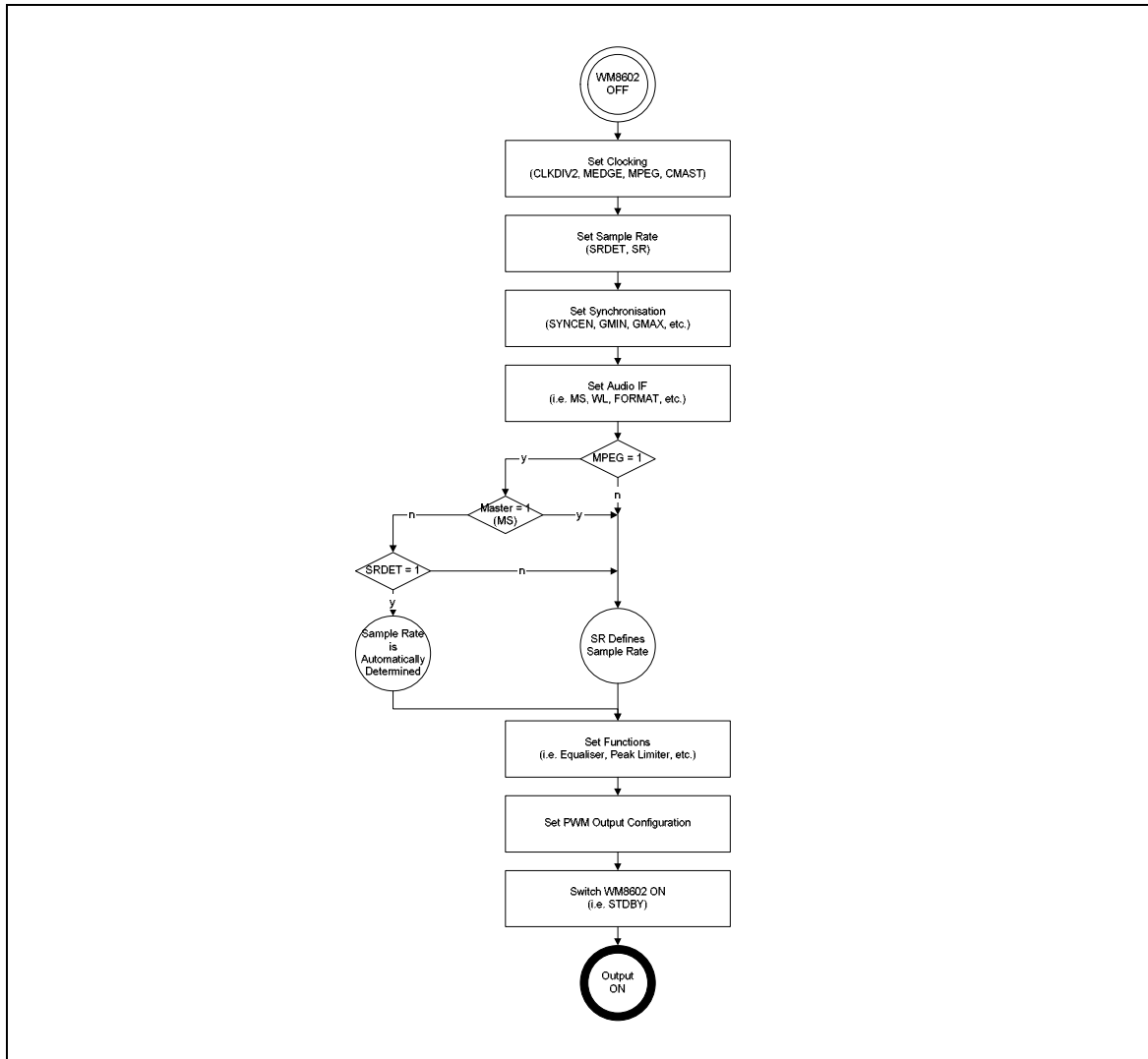

Figure 36 WM8602 Start-up

### POWER SUPPLY CONNECTIONS

The WM8602 has 3 individual power supplies. Figure 37 shows how these power supplies are connected and used on the chip and package.

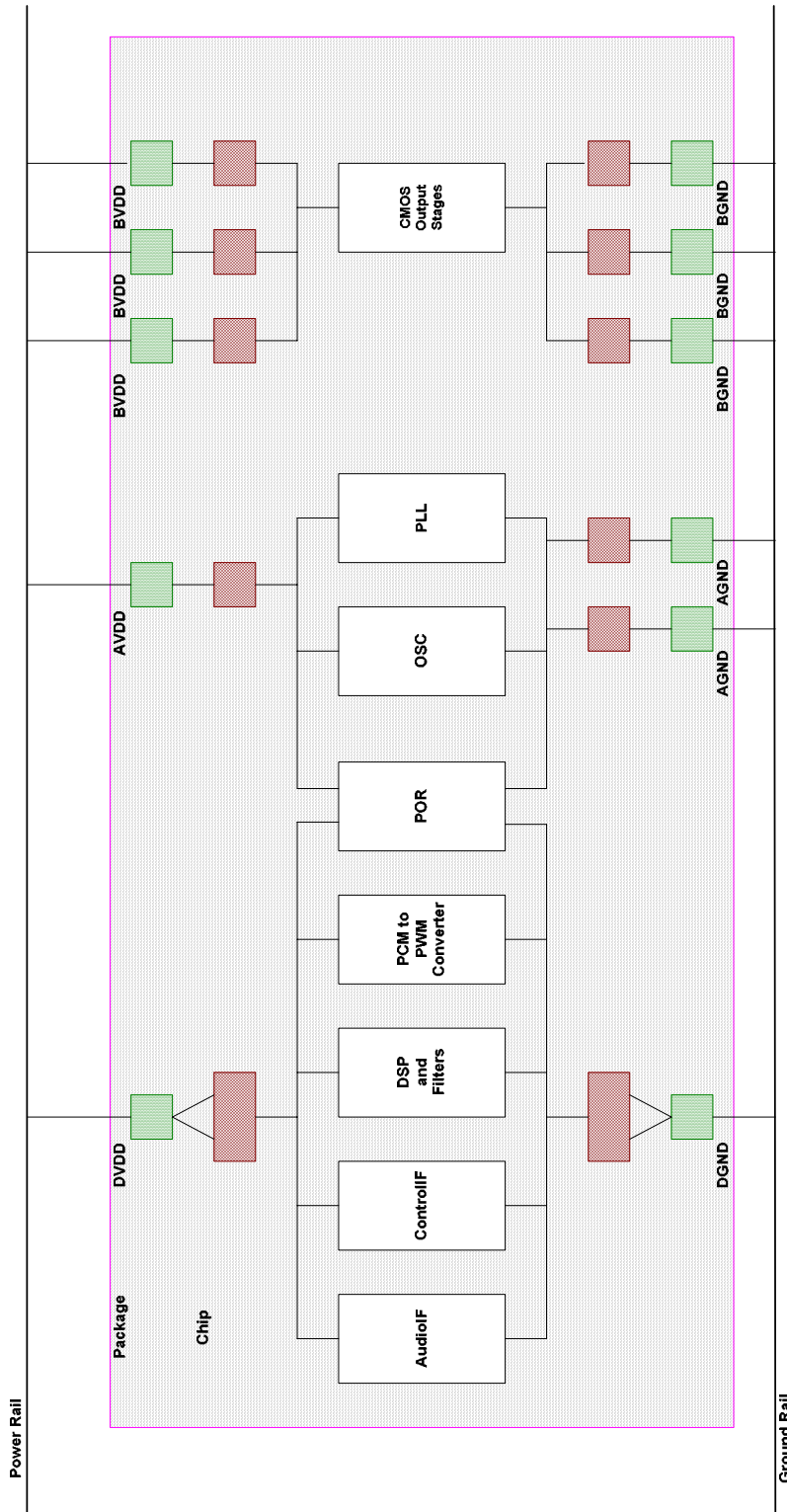

Figure 37 WM8602 Power Supply Connections

APPLICATIONS INFORMATION

RECOMMENDED EXTERNAL COMPONENTS

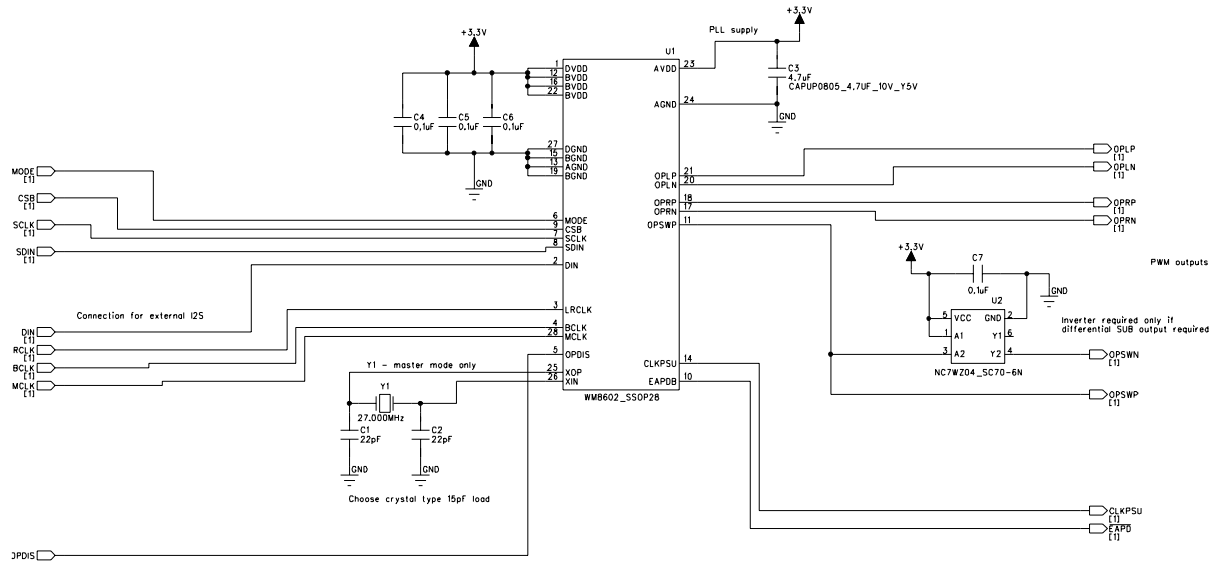

Figure 38 WM8602 External Component Diagram

RECOMMENDED EXTERNAL COMPONENTS VALUES

COMPONENT REFERENCE	SUGGESTED VALUE	DESCRIPTION
Y1	24.576 / 27.000MHz	Crystal (15pF load, 500µW)
C1, C2	22pF	Capacitor NP0 0603
C3	4.7µF	Capacitor Y5V 0805
C4-C7	0.1µF	Capacitor X7R 0603

Table 53 External Components Description

## PACKAGE DIMENSIONS

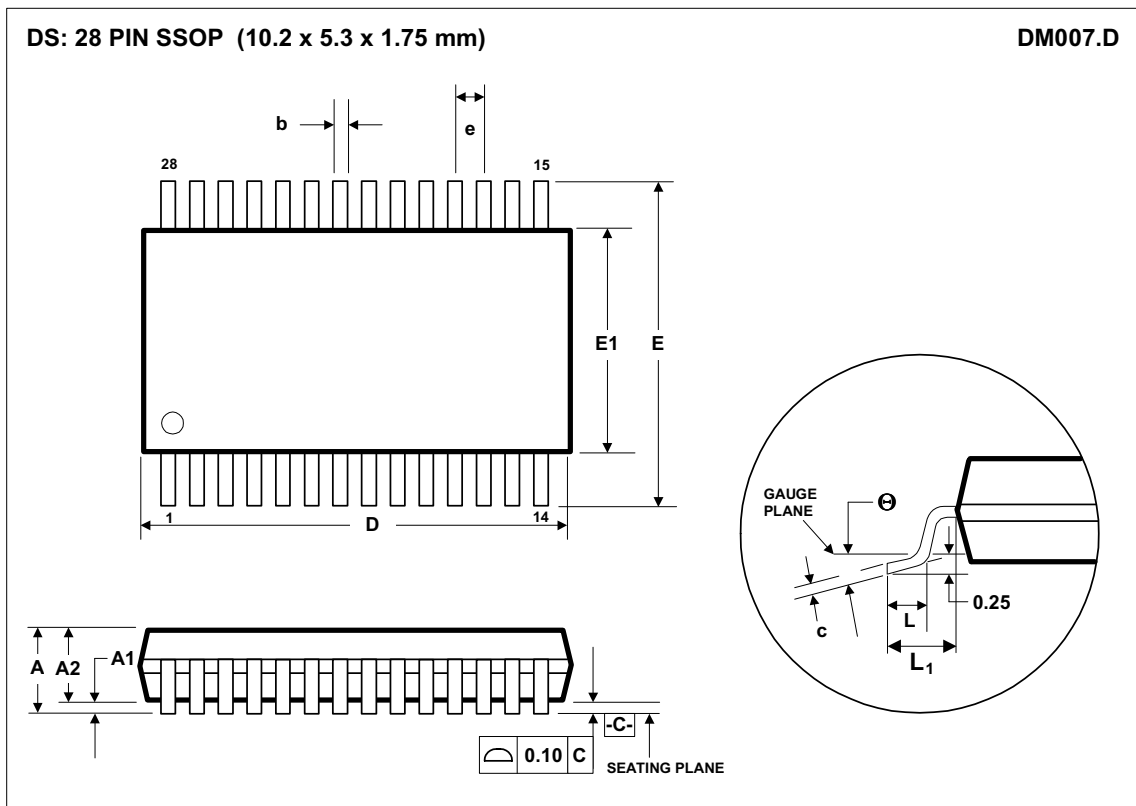

Symbols	Dimensions (mm)		
	MIN	NOM	MAX
A	-----	-----	2.0
A <sub>1</sub>	0.05	-----	0.25
A <sub>2</sub>	1.65	1.75	1.85
b	0.22	0.30	0.38
c	0.09	-----	0.25
D	9.90	10.20	10.50
e	0.65 BSC		
E	7.40	7.80	8.20
E <sub>1</sub>	5.00	5.30	5.60
L	0.55	0.75	0.95
L <sub>1</sub>	0.125 REF		
θ	0°	4°	8°
REF:	JEDEC.95, MO-150		

## NOTES:

- A. ALL LINEAR DIMENSIONS ARE IN MILLIMETERS.  
 B. THIS DRAWING IS SUBJECT TO CHANGE WITHOUT NOTICE.  
 C. BODY DIMENSIONS DO NOT INCLUDE MOLD FLASH OR PROTRUSION, NOT TO EXCEED 0.20MM.  
 D. MEETS JEDEC.95 MO-150, VARIATION = AH. REFER TO THIS SPECIFICATION FOR FURTHER DETAILS.

## IMPORTANT NOTICE

Wolfson Microelectronics plc (WM) reserve the right to make changes to their products or to discontinue any product or service without notice, and advise customers to obtain the latest version of relevant information to verify, before placing orders, that information being relied on is current. All products are sold subject to the WM terms and conditions of sale supplied at the time of order acknowledgement, including those pertaining to warranty, patent infringement, and limitation of liability.

WM warrants performance of its products to the specifications applicable at the time of sale in accordance with WM's standard warranty. Testing and other quality control techniques are utilised to the extent WM deems necessary to support this warranty. Specific testing of all parameters of each device is not necessarily performed, except those mandated by government requirements.

In order to minimise risks associated with customer applications, adequate design and operating safeguards must be used by the customer to minimise inherent or procedural hazards. Wolfson products are not authorised for use as critical components in life support devices or systems without the express written approval of an officer of the company. Life support devices or systems are devices or systems that are intended for surgical implant into the body, or support or sustain life, and whose failure to perform when properly used in accordance with instructions for use provided, can be reasonably expected to result in a significant injury to the user. A critical component is any component of a life support device or system whose failure to perform can be reasonably expected to cause the failure of the life support device or system, or to affect its safety or effectiveness.

WM assumes no liability for applications assistance or customer product design. WM does not warrant or represent that any license, either express or implied, is granted under any patent right, copyright, mask work right, or other intellectual property right of WM covering or relating to any combination, machine, or process in which such products or services might be or are used. WM's publication of information regarding any third party's products or services does not constitute WM's approval, license, warranty or endorsement thereof.

Reproduction of information from the WM web site or datasheets is permissible only if reproduction is without alteration and is accompanied by all associated warranties, conditions, limitations and notices. Representation or reproduction of this information with alteration voids all warranties provided for an associated WM product or service, is an unfair and deceptive business practice, and WM is not responsible nor liable for any such use.

Resale of WM's products or services with statements different from or beyond the parameters stated by WM for that product or service voids all express and any implied warranties for the associated WM product or service, is an unfair and deceptive business practice, and WM is not responsible nor liable for any such use.

### ADDRESS:

Wolfson Microelectronics plc  
Westfield House  
26 Westfield Road  
Edinburgh  
EH11 2QB  
United Kingdom

Tel :: +44 (0)131 272 7000  
Fax :: +44 (0)131 272 7001  
Email :: sales@wolfsonmicro.com