

**Features**

- Single power supply: 4.5V~5.5V
- ADM algorithm
- Auto playback with an echo effect
- DRAM options:
  - 64K
  - 256K
- Sampling rate options:
  - 32K bps (bits per second)
  - 16K bps
- Recording capacity: 2, 4, 8, 16 seconds
- A built-in 2 stage microphone amplifier
- A built-in DRAM refresh circuit
- A voltage type D/A output
- A current type D/A output
- Auto power-off
- Low power dissipation

**Applications**

- Toys
- Educations
- Games

**General Description**

The HT8665 is a single chip CMOS LSI using an ADM algorithm. It is designed for applications on talking back with an echo effect. Functions of the IC consist of recording/playing and auto power off in addition to an echo effect. The IC starts recording when a sound input is detected, and stops to play back when silence lasts 0.5 seconds during recording. The auto power off function is activated once a REC/PLAY cycle has been implemented 64 times or an interval of silence exceeds 2 minutes.

The HT8665 provides a recording capacity of 2 seconds at a 32K bps sampling rate for DRAM of 64K (8 seconds for DRAM of 256K) and 4 seconds at a 16K bps sampling rate (16 seconds for DRAM of 256Kb). A higher sampling rate results in sounds of better quality but sacrifices the recording time, and vice versa.



**Pad Coordinates**

 Unit:  $\mu\text{m}$ 

Pad No.	X	Y	Pad No.	X	Y
1	-1447.00	977.75	18	1447.00	-452.75
2	-1434.00	648.25	19	1447.00	-189.75
3	-1447.00	354.75	20	1447.00	75.25
4	-1447.00	99.25	21	1442.00	434.25
5	-1429.50	-178.75	22	1447.00	718.75
6	-1447.00	-1004.75	23	1447.00	999.75
7	-1450.00	-1300.75	24	1346.00	1300.75
8	-1106.50	-1300.75	25	1020.00	1300.75
9	-813.00	-1300.75	26	741.00	1300.75
10	-31.00	-1300.75	27	460.00	1300.75
11	296.00	-1300.75	28	181.00	1300.75
12	626.00	-1300.75	29	-100.00	1300.75
13	881.50	-1300.75	30	-393.00	1300.75
14	1143.50	-1300.75	31	-674.00	1300.75
15	1447.00	-1305.75	32	-983.50	1300.75
16	1447.00	-965.25	33	-1340.00	1300.75
17	1447.00	-717.75			

**Pin Description**

Pin No.	Pin Name	I/O	Internal Connection	Description
1	A0	O	CMOS	DRAM address output
2	RASB	O	CMOS	DRAM row address strobe
3	WRB	O	CMOS	DRAM write enable
4	DATA	I/O	CMOS	DRAM data input/output
5	A8	O	CMOS	DRAM address output
6	NC	—	—	No connection
7	CASB	O	CMOS	DRAM column address strobe
8	VDD	I	—	Positive power supply
9	MOTOR	O	CMOS	Motor drive output (active high)
10	LEDB	O	NMOS Open Drain	LED indicator: Idle: LED is turned on; Record: LED flashes; Play: LED is turned off.
11	IOUT	O	PMOS Open Drain	Current type audio output for an external transistor

Pin No.	Pin Name	I/O	Internal Connection	Description
12	NC	—	—	No connection
13	VOUT	O	—	Voltage type audio output for an external power AMP
14	MIXIN	I	—	Echo mixer input
15	NC	—	—	No connection
16	NC	—	—	No connection
17	NC	—	—	No connection
18	MIXOUT	O	—	Echo mixer output
19	OSC1	I	—	Oscillator input
20	OSC2	O	—	Oscillator output
21	ADMOUT	O	—	ADM D/A output
22	BIAS	O	—	For OP bias de-coupling
23	AO1	O	—	Internal AMP first stage output
24	AIN2	I	—	Internal AMP second stage input (inverting)
25	NC	—	—	No connection
26	AIN1	I	—	Internal AMP first stage input (inverting)
27	START	O	CMOS	System start pin
28	16KB	I	Pull-High	Sampling rate selection: Open/high: 32K bps; Low: 16K bps
29	TESTB	I	Pull-Low	For IC test only
30	DS	I	Pull-High	Echo delay time selection: 1. DRAM of 64K: Open/high: 256ms; Low: 128ms 2. DRAM of 256K: Open/high: 512ms; Low: 256ms
31	MS	I	Pull-High	DRAM size selection: Open/high: 64K; Low: 256K
32	VSS	I	—	Negative power supply (GND)
33	A7	O	CMOS	DRAM address output
34	A6	O	CMOS	DRAM address output
35	NC	—	—	No connection
36	A5	O	CMOS	DRAM address output

Pin No.	Pin Name	I/O	Internal Connection	Description
37	A4	O	CMOS	DRAM address output
38	A3	O	CMOS	DRAM address output
39	A1	O	CMOS	DRAM address output
40	A2	O	CMOS	DRAM address output

**Absolute Maximum Ratings**

Supply Voltage ..... -0.3V to 6V      Storage Temperature..... -50°C to 125°C  
 Input Voltage.....  $V_{SS}-0.3V$  to  $V_{DD}+0.3V$       Operating Temperature..... -20°C to 70°C

**Electrical Characteristics**

(Ta=25°C)

Symbol	Parameter	Test Condition		Min.	Typ.	Max.	Unit
		V <sub>DD</sub>	Condition				
V <sub>DD</sub>	Operating Voltage	—	—	4.5	—	5.5	V
I <sub>OP</sub>	Operating Current	5V	No load, F <sub>OSC</sub> =1MKHz	—	3	6	mA
I <sub>OH1</sub>	IOUT Max. Source Current	5V	V <sub>OH</sub> =0.5V	-1.5	-3	—	mA
I <sub>OH2</sub>	MOTOR Source Current	5V	V <sub>OH</sub> =4.5	-1	-3.5	—	mA
I <sub>OL</sub>	LED Sink Current	5V	V <sub>OH</sub> =0.5V	3	-3.5	—	mA
V <sub>IH</sub>	“H” Input Voltage	—	—	0.7V <sub>DD</sub>	—	V <sub>DD</sub>	V
V <sub>IL</sub>	“L” Input Voltage	—	—	0	—	0.3V <sub>DD</sub>	V
V <sub>OUT</sub>	Max. V <sub>OUT</sub> Output Voltage	5V	R <sub>L</sub> >50K	—	1.5	—	V <sub>P-P</sub>
F <sub>OSC</sub>	System Frequency	5V	R <sub>OSC</sub> =27K	—	1	—	MHz

### Functional Description

The HT8665 is a single chip LSI with an external DRAM. It is designed for applications on talking back with an echo effect. The recording length of the IC is decided by the data rate along with the size of an external memory. Sounds input from an external microphone are coded through an internal ADM algorithm and saved in an external memory until the memory is full or an interval of silence lasts over 0.5 seconds. Once recording is terminated, the IC will play back the recorded sounds with an echo effect automatically.

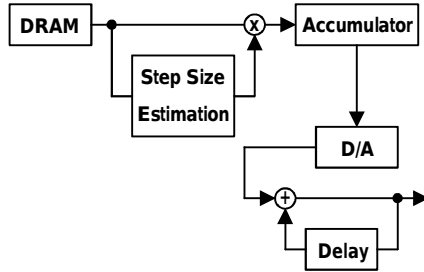

### Record function

The HT8665 provides 2 kinds of sampling rate as well as DRAM interfaces. The sampling rate (S.R.) along with DRAM determine the recording capacity as shown in the following table: (for  $F_{OSC}=640$  KHz)

MS (DRAM)	16KB (S.R.)	Recording Capacity
1 (64Kb)	1 (32K bps)	2 seconds
1 (64Kb)	0 (16K bps)	4 seconds
0 (256Kb)	1 (32K bps)	8 seconds
0 (256Kb)	0 (16K bps)	16 seconds

Notes: "1" is connected to VDD or left open.  
 "0" is connected to VSS.

Recording starts whenever a sound input is detected. It then stops once silence is detected or the recording capacity is full. After that, talking back comes into play.

### Play function

The HT8665 stops to play back the recorded sounds when an interval of silence lasts 0.5 seconds or the memory is full during recording. Its playing rate is the same as the rates of recording and echo effect. The echo delay time is settable by the DS pin as shown.

	DS	1	0
DRAM			
64Kb		256ms	128ms
256Kb		512ms	256ms

### Power control

The HT8665 provides a START pin for power control. The START pin is of high impedance and switch Q is turned off at initial. After the START key is triggered, it will output a high level signal and switch Q is turned on. This pin outputs a low level signal and the power of LSI is switched off when a REC/PLAY cycle has been implemented 64 times or an interval of silence lasts over 2 minutes.

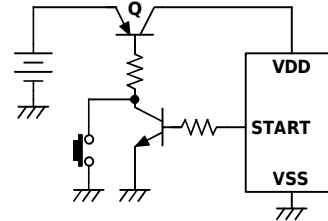

### Motor

The HT8665 provides a motor driving pin. The motor is turned on during playing but off once talking back is terminated.

### Status display

The HT8665 provides an LEDB pin to display its operation status. An external LED is switched on when the IC is in the standby state. It, on the other hand, is switched off when the IC is in the playing state. The LED will flash with the sound volume when the IC is in the recording state, but its intensity will vary inversely with the volume.

Flowchart

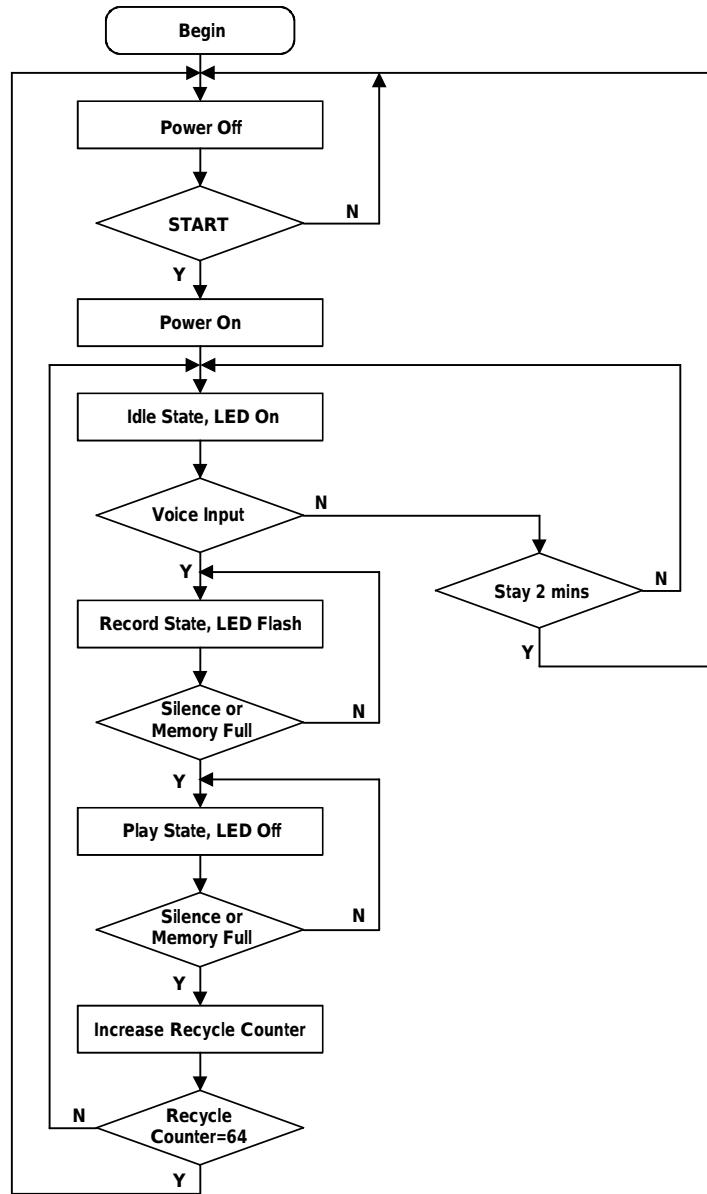

Application Circuits

LM386 output

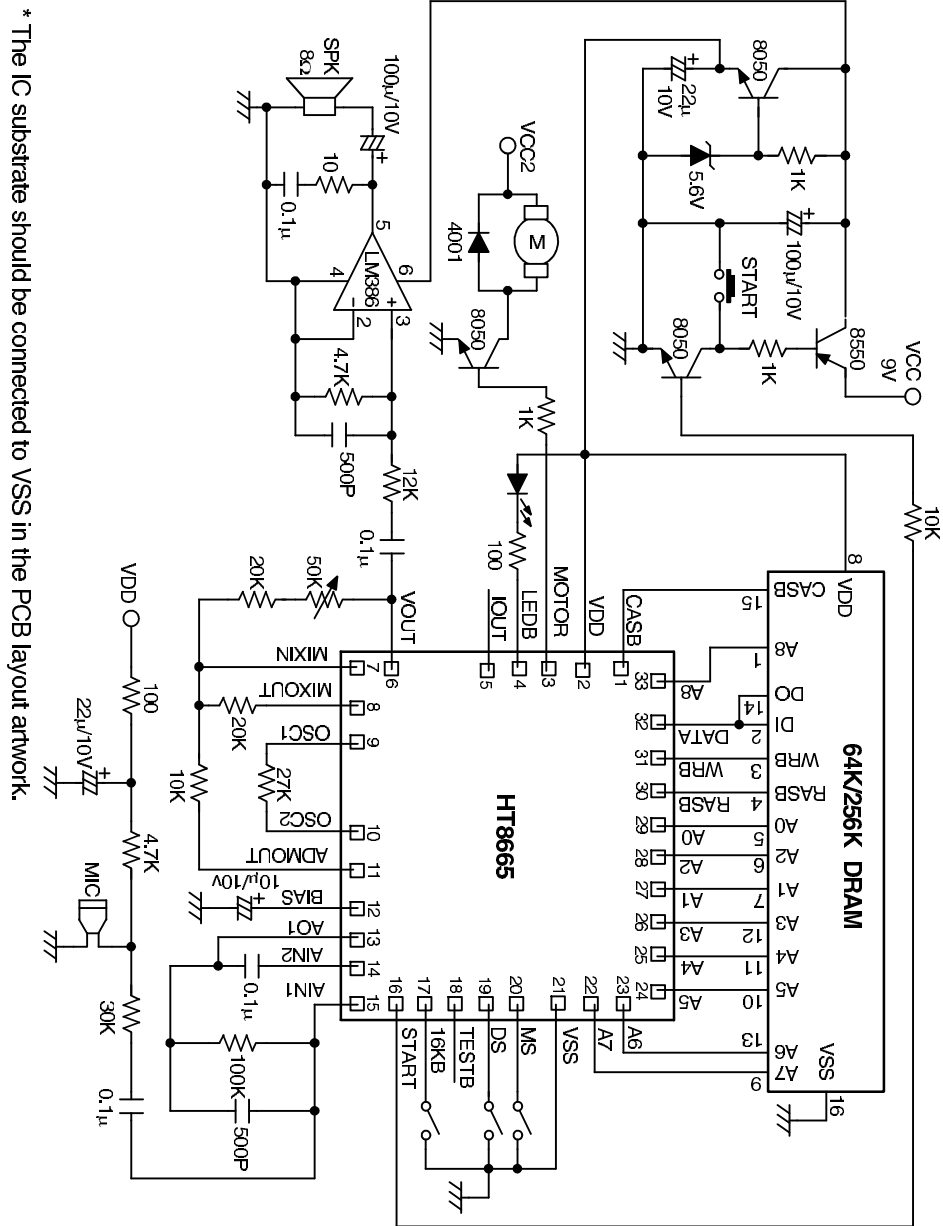

\* The IC substrate should be connected to VSS in the PCB layout artwork.







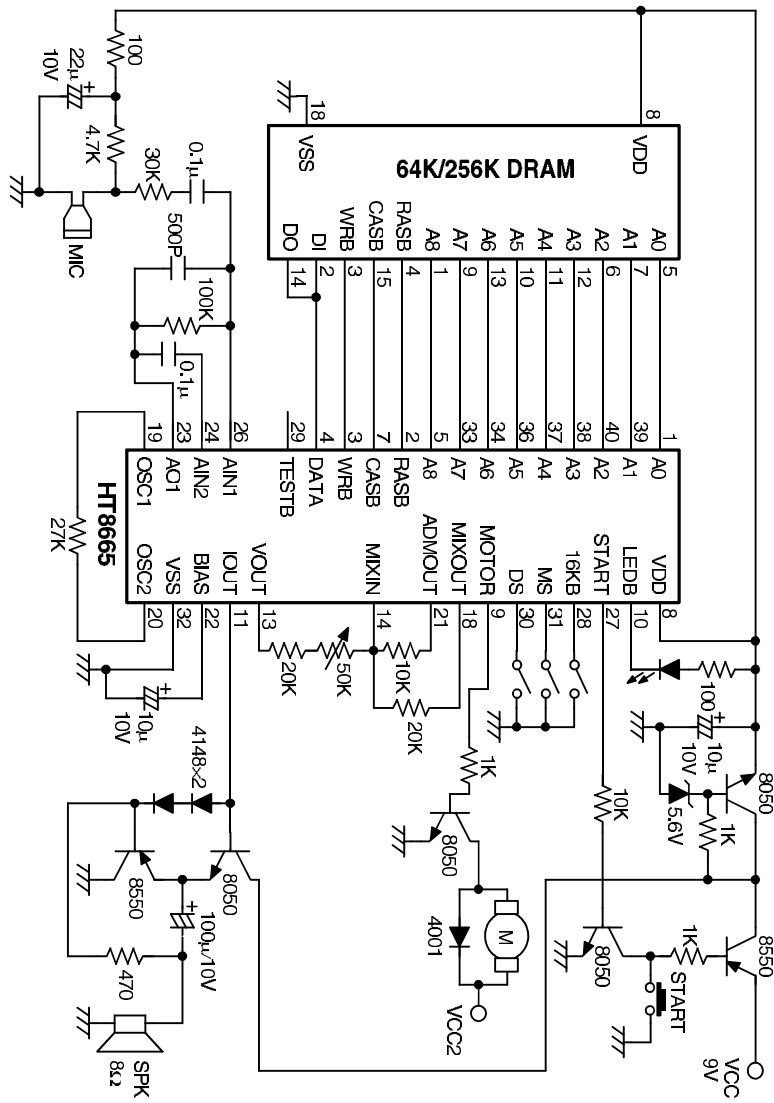

LM324 output

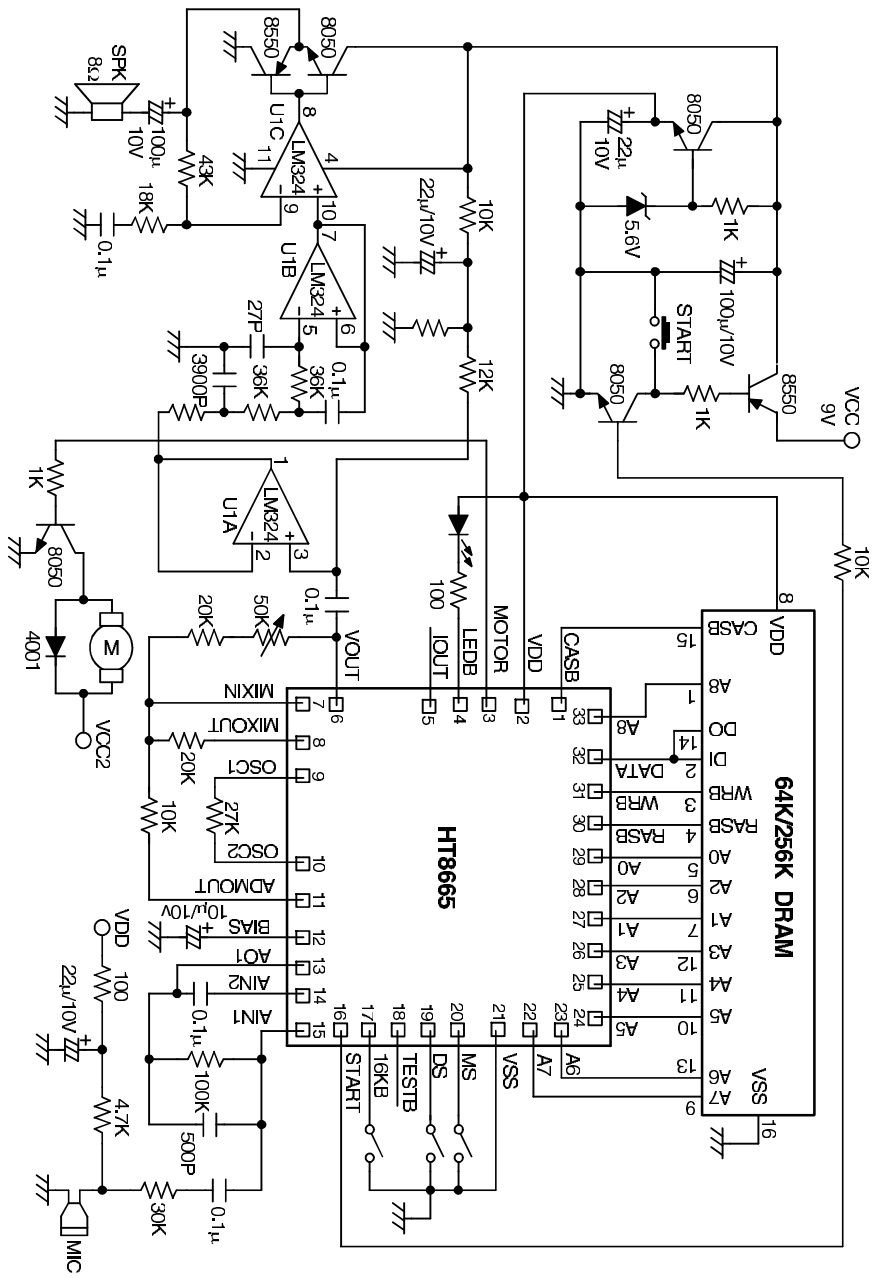

\* The IC substrate should be connected to VSS in the PCB layout artwork.

