

---

# HL6321/22G

AlGaInP Laser Diodes

# HITACHI

---

## Description

The HL6321/22G are 0.63  $\mu\text{m}$  band AlGaInP laser diodes with a multi-quantum well (MQW) structure. They are suitable as light sources for laser levelers and optical equipment for measurement.

## Application

- Laser levelers
- Measurement

## Features

- Visible light output: 635nm Typ (nearly equal to He-Ne gas laser)
- Optical output power: 15 mW CW
- Low operating current: 105 mA Max
- Low operating voltage: 2.7 V Max

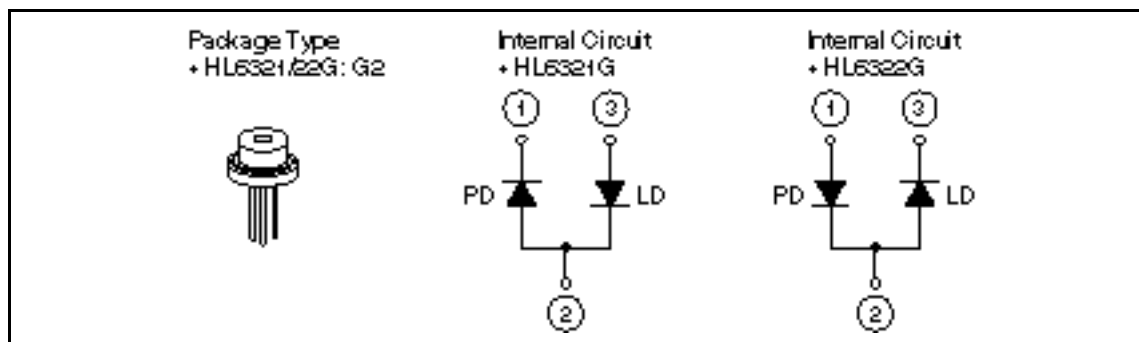

---

## HL6321/22G

---

### Absolute Maximum Ratings ( $T_C = 25^\circ\text{C}$ )

Item	Symbol	Value	Unit
Optical output power	$P_o$	15	mW
LD reverse voltage	$V_{R(LD)}$	2	V
PD reverse voltage	$V_{R(PD)}$	30	V
Operating temperature	$T_{opr}$	-10 to +50	$^\circ\text{C}$
Storage temperature	$T_{stg}$	-40 to +85	$^\circ\text{C}$

### Optical and Electrical Characteristics ( $T_C = 25^\circ\text{C}$ )

Item	Symbol	Min	Typ	Max	Unit	Test Conditions
Optical output power	$P_o$	15	—	—	mW	Kink free
Threshold current	$I_{th}$	20	—	75	mA	
Operating current	$I_{OP}$	—	—	105	mA	$P_o = 15\text{ mW}$
Operating voltage	$V_{OP}$	—	—	2.7	V	$P_o = 15\text{ mW}$
Slope efficiency	$s$	0.3	—	0.7	mW/mA	$9(\text{mW})/(I(12\text{mW})-I(3\text{mW}))$
Lasing wavelength	$p$	625	635	642	nm	$P_o = 15\text{ mW}$
Beam divergence (parallel)	//	5	8	11	deg.	$P_o = 15\text{ mW}$
Beam divergence (perpendicular)		24	30	36	deg.	$P_o = 15\text{ mW}$
Monitor current	$I_s$	0.07	0.26	0.45	mA	$P_o = 15\text{ mW}, V_{R(PD)} = 5\text{ V}$

**Polarization direction**

The polarization direction is TM mode. The polarization of 0.63  $\mu\text{m}$  LD's is different from that of 0.83/0.78/0.67  $\mu\text{m}$  LD's. The polarization direction of 0.63  $\mu\text{m}$  LD's is illustrated in the figure below.

