

25W, 2.7 GHz, 28V Broadband RF Power N-Channel Enhancement-Mode Lateral MOSFET

Designed for base station applications in the frequency band 2.5 to 2.7 GHz. Rated with a minimum output power of 25W, it is ideal for CW and Multi-Tone Amplifiers in Class AB operation.

- ALL GOLD metal system for highest reliability
- Industry standard package
- Internally matched for repeatable manufacturing
- High gain, high efficiency and high linearity
- Integrated ESD Protection.
- Maximum gain and insertion phase flatness.
- Output load VSWR tolerance 10:1 all phase angles at 28V_{DC}, 2500MHz, 25W (CW) output power.
- Common source.

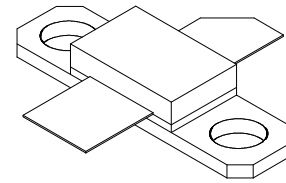

Package Type 440159

PN: UGF27025F

- **Application Specific Performance, 2.7 GHz**

- **Typical 2-Tone Performance**

- Average Load Power – 12.5 W

- η_D – 30%

- Power Gain – 11.5 dB

- IMD3: -30dBc @ -100kHz/ +100kHz

- VDD – 28V

- IDQ – 330mA

- **Typical CW Performance**

- Average Load Power – 25 W

- η_D – 38%

- Power Gain – 11.0 dB

- VDD – 28V

- IDQ – 330mA

Maximum Ratings

Rating	Symbol	Value	Unit
Drain to Source Voltage, Gate connected to Source	V_{DSS}	65	Volts
Gate to Source Voltage	V_{GSS}	+15 to -0.5	Volts
Total Device Dissipation @ Tcase = 70°C Derate above 70°C	P_D	83.5 0.48	Watts W/°C
Storage Temperature Range	T_{stg}	-65 to +150	°C
Maximum Operating Junction Temperature	T_J	200	°C

Thermal Characteristics

Characteristic	Symbol	Typical	Unit
Thermal Resistance, Junction to Case	Θ_{JC}	2.1	°C/W

Electrical DC Characteristics (Tc=25°C unless otherwise specified)

Rating	Symbol	Min	Typ	Max	Unit
Drain to Source Breakdown Voltage ($V_{GS}=0$, $I_D=1mA$)	BV_{DSS}	65	-	-	Volts
Drain to Source Leakage current ($V_{DS}=28V$, $V_{GS}=0$)	I_{DSS}	-	-	1.0	mA
Gate to Source Leakage current ($V_{GS}=15V$, $V_{DS}=0$)	I_{GSS}	-	-	1.0	μA
Threshold Voltage ($V_{DS}=10V$, $I_D=1mA$)	$V_{GS(th)}$	-	3.5	-	Volts
Gate Quiescent Voltage ($V_{DS}=28V$, $I_D=330mA$)	$V_{GS(Q)}$	3.0	4.0	5.0	Volts
Drain to Source On Voltage ($V_{GS}=10V$, $I_D=1A$)	$V_{DS(on)}$	-	-	0.33	Volts
Forward Transconductance ($V_{DS}=10V$, $I_D=1A$)	Gm	1.0	-	-	S

AC Characteristics (Tc=25°C unless otherwise specified)

Rating	Symbol	Min	Typ	Max	Unit
Input capacitance * (including matching capacitor) (V _{DS} =28V, V _{GS} =0V, f = 1MHz)	C _{ISS}	-	74	-	pF
Output capacitance * (including matching capacitor) (V _{DS} = 28V, V _{GS} =0V, f = 1MHz)	C _{OSS}	-	352	-	pF
Feedback capacitance * (V _{DS} =28V, V _{GS} =0V, f = 1MHz)	C _{RSS}	-	1.6	-	pF

* Part is internally matched on input and output.

RF and Functional Tests (In Cree Microwave Broadband Fixture, Tc=25° C unless otherwise specified)

Rating	Symbol	Min	Typ	Max	Unit
CW Low Power Gain, P _{out} =8W V _{DD} =28V, I _{DQ} =330mA, f=2700 MHz	G _L	11	12	-	dB
CW Power Gain, P _{out} = 25 W V _{DD} =28V, I _{DQ} =330mA, f=2700 MHz	G _P	10	11	-	dB
CW Drain Efficiency, P _{out} = 25 W, f=2700 MHz, V _{DD} =28V, I _{DQ} =330mA	η _D	34	38	-	%
Two-Tone Common-Source Amplifier Power Gain V _{DD} =28V, I _{DQ} =330mA, P _{out} = 25 W PEP f ₁ =2700 MHz and f ₂ =2700.1 MHz	G _{TT}	10.5	11.5	-	dB
Two-Tone Intermodulation Distortion V _{DD} =28V, I _{DQ} =330mA, P _{out} = 25 W PEP f ₁ =2700 MHz and f ₂ =2700.1 MHz	I _{MD}	-	-30	-28	dBc
Two-Tone Drain Efficiency V _{DD} =28V, I _{DQ} =330mA, P _{out} = 25 W PEP f ₁ =2700 MHz and f ₂ =2700.1 MHz	η _{D2T}	26	30	-	%
Input Return Loss V _{DD} =28V, P _{out} = 25 W PEP, I _{DQ} =330mA f ₁ =2500 MHz and 2700 MHz, Tone Spacing = 100kHz	IRL	-	-	-9	dB
Load Mismatch Tolerance V _{DS} =28V, I _{DQ} = 330 mA, P _{out} =25W, f=2500 MHz	VSWR	10:1	-	-	Ψ

CAUTION - MOS Devices are susceptible to damage from Electrostatic Discharge (ESD). Appropriate precautions in handling, packaging and testing MOS devices must be observed.

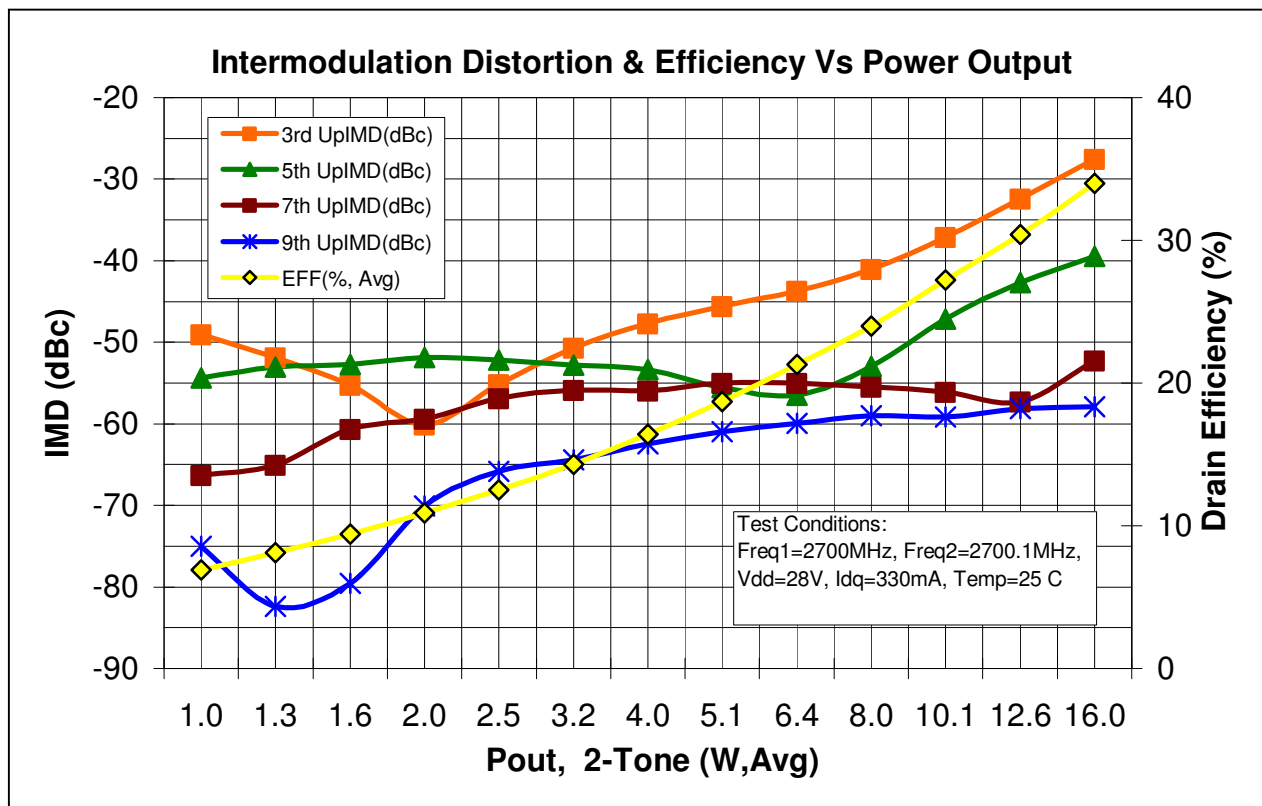
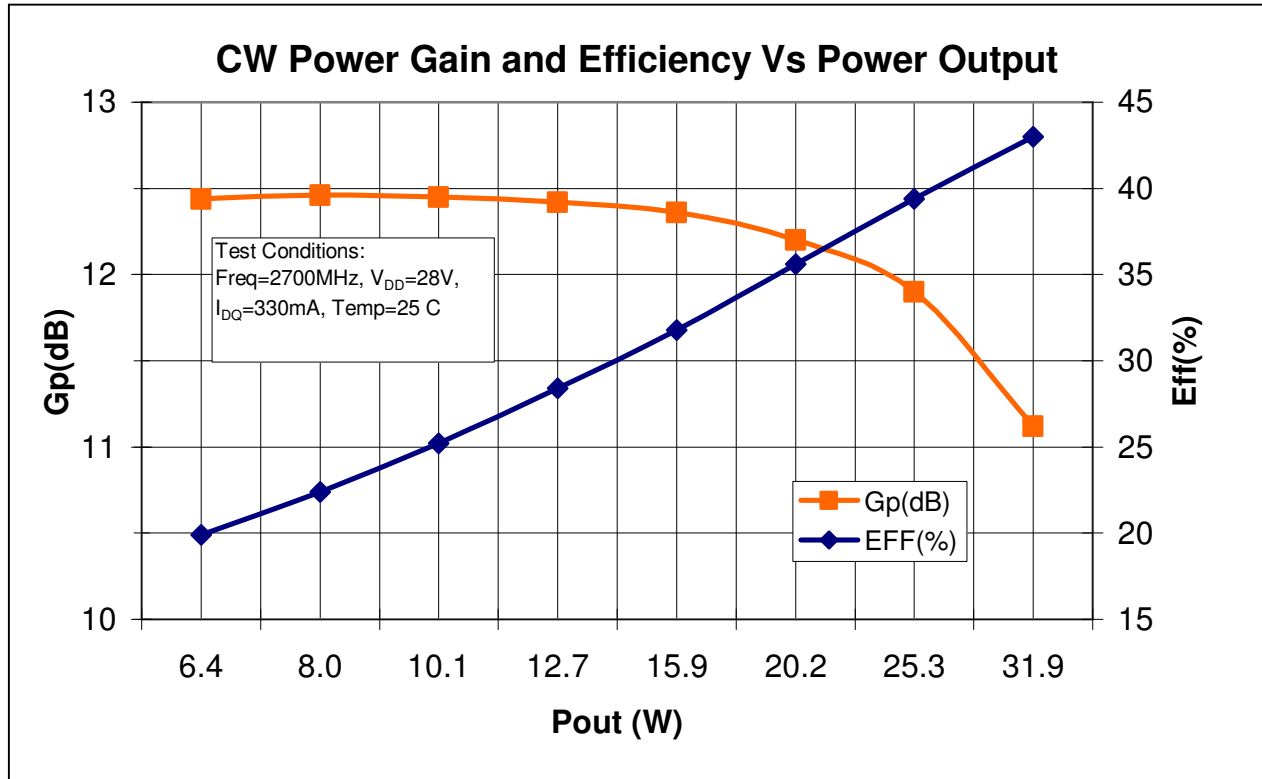

Test Fixture

Test Fixture Layout for 2.5-2.7GHz

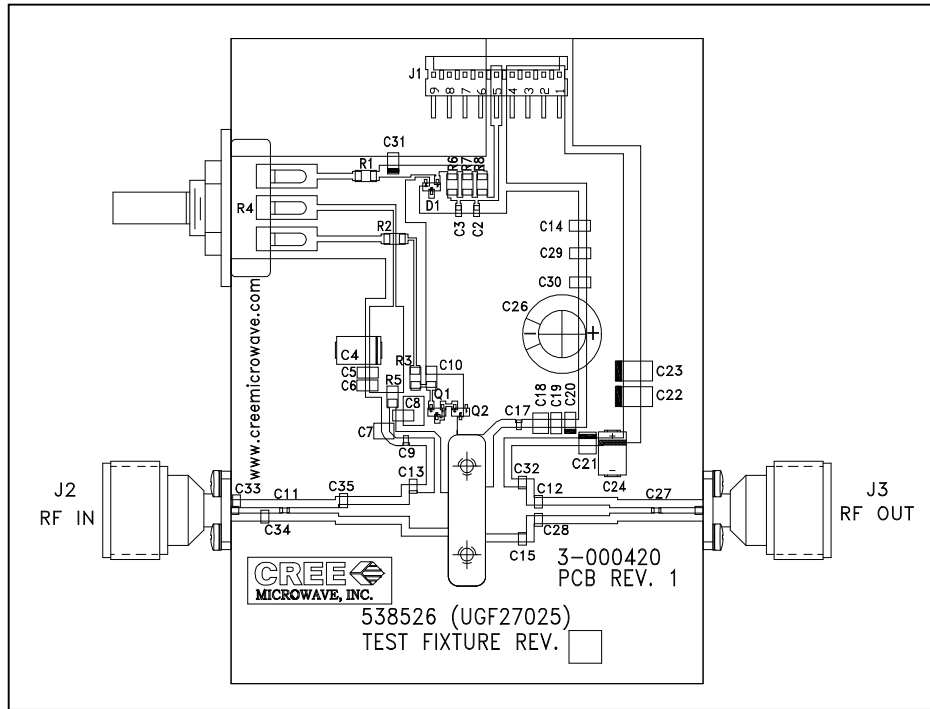

Test Fixture Schematic

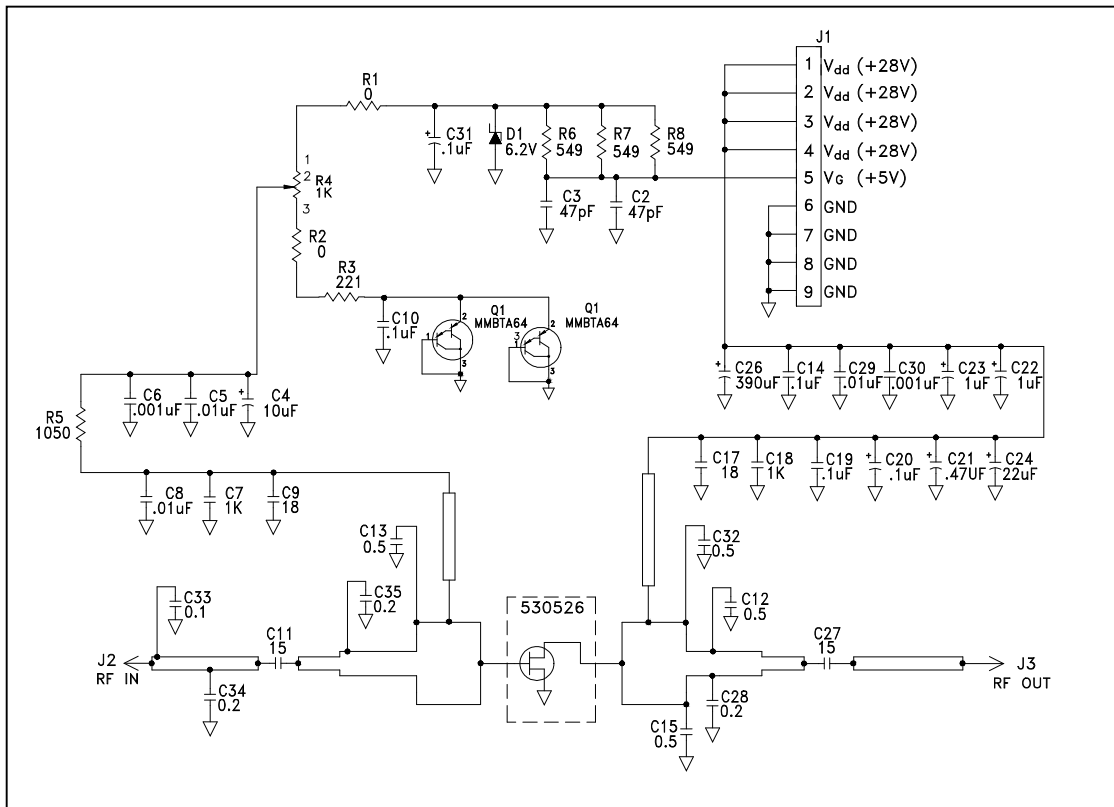

Product Dimensions

UGF27025F -Package Number 440159

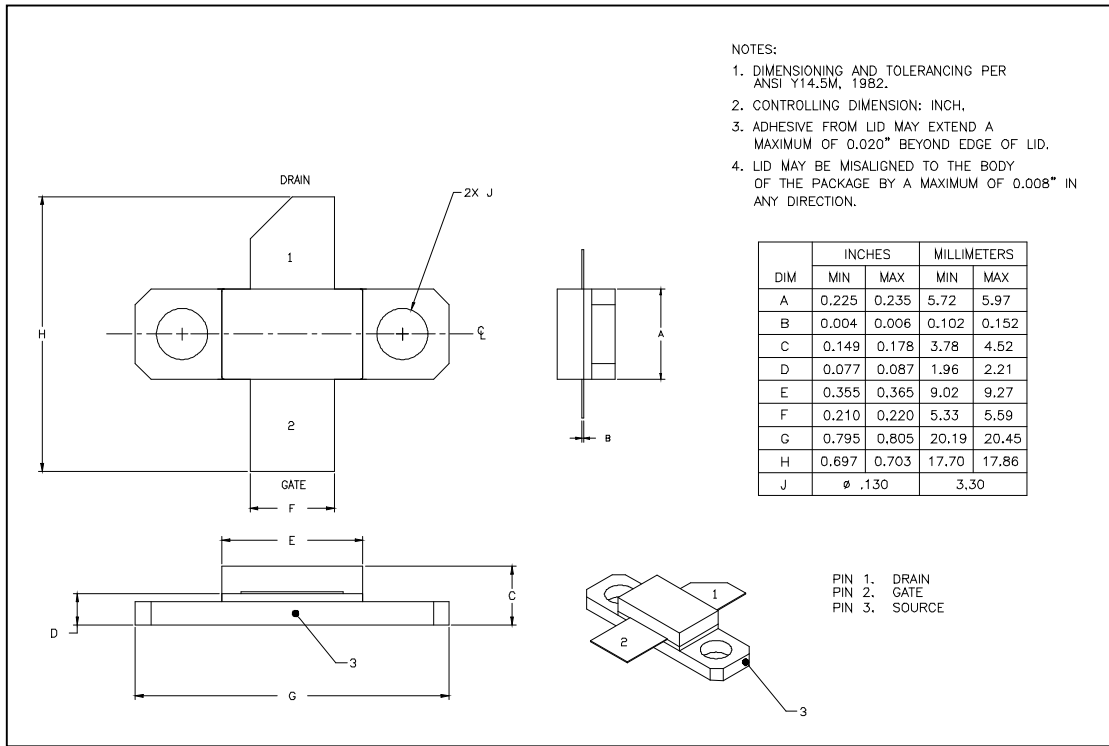



UGF27025

Disclaimer: Specifications are subject to change without notice. Cree Microwave, Inc. believes the information contained within this data sheet to be accurate and reliable. However, no responsibility is assumed by Cree Microwave for any infringement of patents or other rights of third parties which may result from its use. No license is granted by implication or otherwise under any patent or patent rights of Cree Microwave. Cree Microwave makes no warranty, representation or guarantee regarding the suitability of its products for any particular purpose. "Typical" parameters are the average values expected by Cree Microwave in large quantities and are provided for information purposes only. These values can and do vary in different applications, and actual performance can vary over time. All operating parameters should be validated by customer's technical experts for each application. Cree Microwave products are not designed, intended, or authorized for use as components in applications intended for surgical implant into the body or to support or sustain life, in applications in which the failure of the Cree product could result in personal injury or death, or in applications for planning, construction, maintenance or direct operation of a nuclear facility. Cree Microwave is a trademark and Cree and the Cree logo are registered trademarks of Cree, Inc.

Contact Information:

Cree Microwave, Inc.
160 Gibraltar Court
Sunnyvale, CA 94089-1319

Sheryle Henson (Cree Microwave—Marketing Manager) 408-962-7783
Tom Dekker (Cree Microwave—Sales Director) 919-313-5639