

**16-Bit Buffer/Driver
with 3-State Outputs**
Features

- The PI74VCX Family is designed for low voltage operation, $V_{DD} = 1.8V$ to $3.6V$
- 3.6V Tolerant Inputs and Outputs
- Supports Live Insertion
- Balanced Drive, $\pm 24mA$
- Uses patented Noise Reduction Circuitry
- Typical V_{OLP} (Output Ground Bounce) $< 0.6V$ at $V_{DD} = 2.5V$, $T_A = 25^\circ C$
- Typical V_{OHV} (Output V_{OH} Undershoot) $< -0.6V$ at $V_{DD} = 2.5V$, $T_A = 25^\circ C$
- Power-Off high impedance inputs and outputs
- Industrial operation at $-40^\circ C$ to $+85^\circ C$
- Packaging (Pb-free & Green available):
–48-pin 240-mil wide plastic TSSOP (A)

Description

Pericom Semiconductor's PI74VCX16244 buffer/driver is designed specifically to improve both the performance and density of 3-state memory address drivers, clock drivers, and bus-oriented receivers and transmitters.

The device can be used as four 4-bit buffers, two 8-bit buffers, or one 16-bit buffer. It provides true outputs and symmetrical active-low output-enable (\overline{OE}) inputs.

To ensure the high-impedance state during power up or power down, \overline{OE} should be tied to V_{CC} through a pullup resistor; the minimum value of the resistor is determined by the current-sinking capability of the driver.

The PI74VCX family is I/O Tolerant, allowing it to operate in 1.8/3.6V systems.

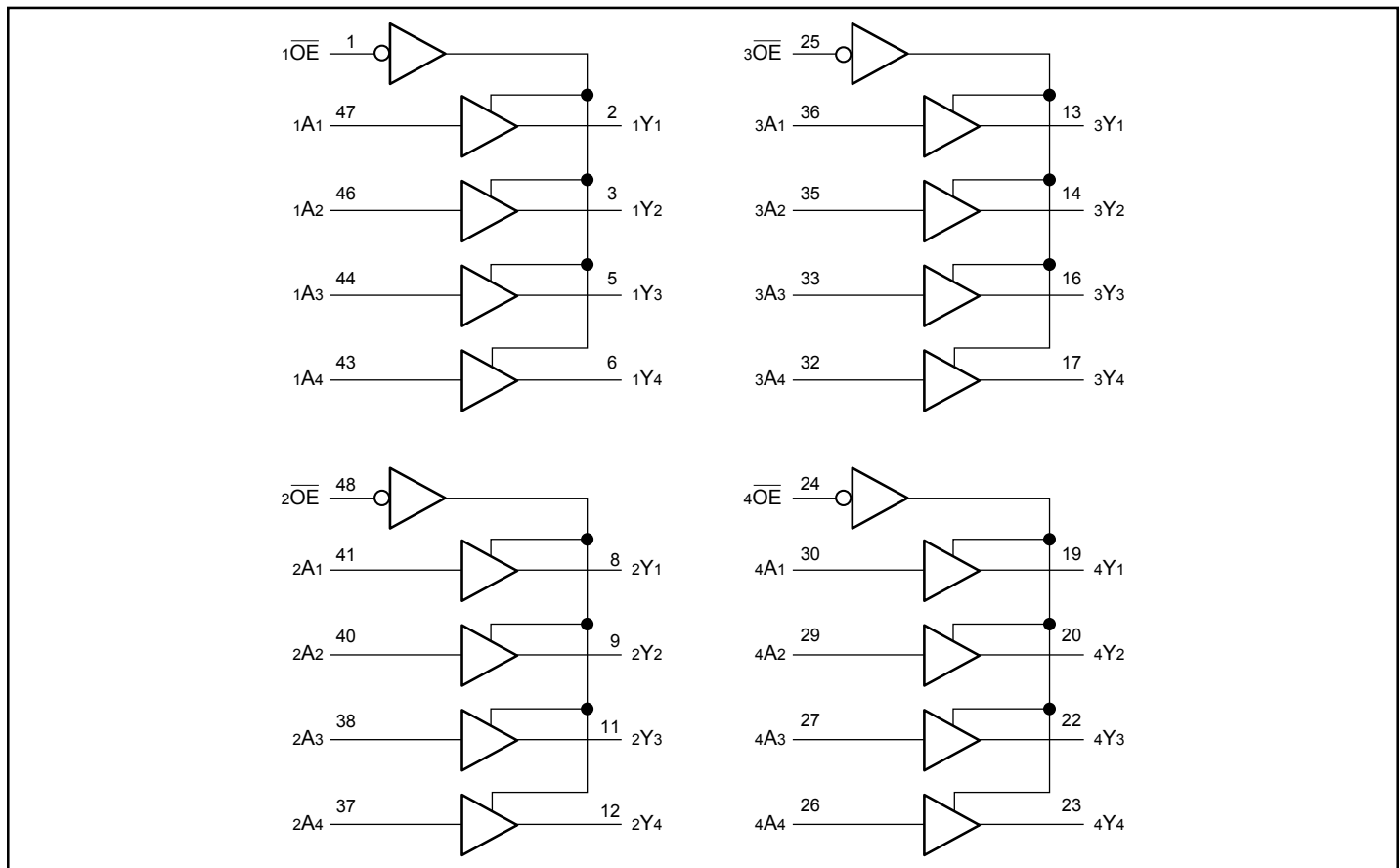
Block Diagram

Pin Description

Pin Name	Description
nOE	3-State Output Enable Inputs (Active LOW)
nAx	Inputs
nYx	3-State Outputs
GND	Ground
Vcc	Power

Truth Table⁽¹⁾

Inputs		Outputs
nOE	nAx	nYx
L	H	H
L	L	L
H	X	Z

Notes:

- H = High Signal Level
L = Low Signal Level
X = Don't Care or Irrelevant
Z = High Impedance

Pin Configuration

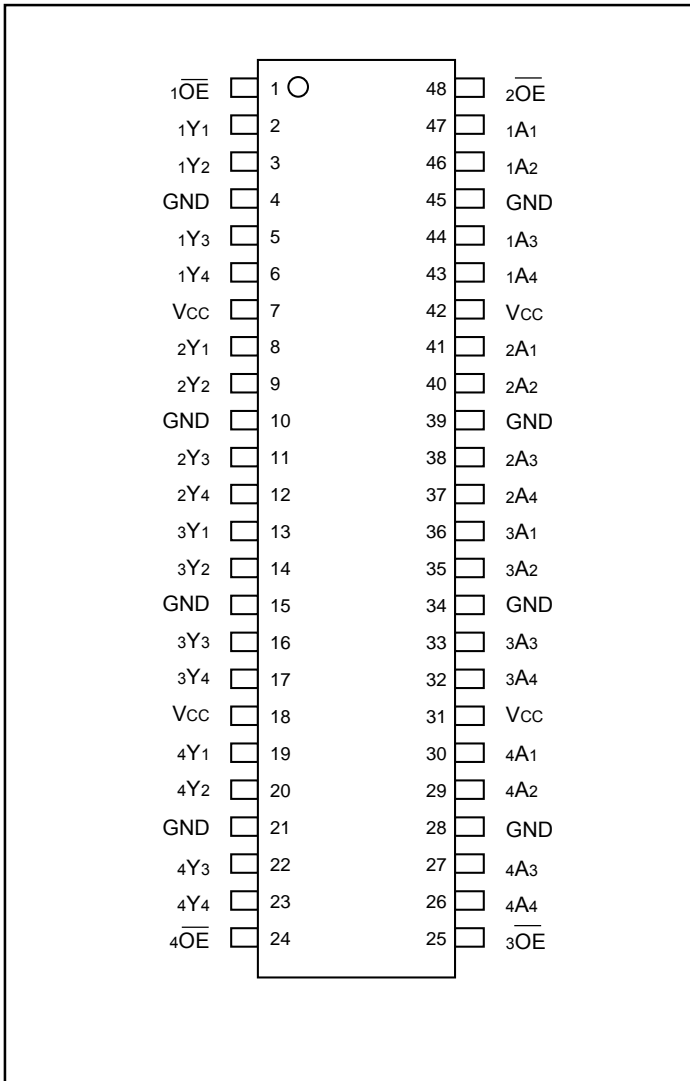

Maximum Ratings

(Above which the useful life may be impaired. For user guidelines, not tested.)

Supply Voltage Range, V_{DD}	0.5V to 4.6V
Input Voltage Range, V_I	-0.5V to 4.6V
Output Voltage Range, V_O (3-States)	-0.5V to 4.6V
Output Voltage Range, $V_O^{(1)}$ (Active)	-0.5V to $V_{CC}+0.5$
DC Input Diode Current (I_{IK}) $V_I < 0V$	-50mA
DC Output Diode Current (I_{OK}) $V_O < 0V$	-50mA
$V_O > V_{DD}$	+50mA
DC Output Source/Sink Current (I_{OH}/I_{OL})	$\pm 50mA$
DC V_{DD} or GND Current per Supply Pin (I_{CC} or GND)	$\pm 100mA$
Storage Temperature Range, T_{stg}	-65°C to 150°C

Note:

Stresses greater than those listed under MAXIMUM RATINGS may cause permanent damage to the device. This is a stress rating only and functional operation of the device at these or any other conditions above those indicated in the operational sections of this specification is not implied. Exposure to absolute maximum rating conditions for extended periods may affect reliability.

Recommended Operating Conditions⁽²⁾

			Min.	Max.	Units
V_{DD}	Supply voltage	Operating	1.8	3.6	V
		Data Retention Only	1.2	3.6	
V_{IH}	High-level input voltage	$V_{DD} = 2.7V$ to 3.6V	2.0		
V_{IL}	Low-level input voltage	$V_{DD} = 2.7V$ to 3.6V		0.8	
V_I	Input voltage		-0.3	3.6	
V_O	Output voltage	Active State	0	V_{DD}	
		Off State	0	3.6	
I_O	Output current in I_{OH}/I_{OL}	$V_{DD} = 3.0V$ to 3.6V $V_{DD} = 2.3V$ to 2.7V $V_{DD} = 1.8V$		± 24 ± 18 ± 6	mA
$\Delta t/\Delta v$	Input transition rise or fall rate ⁽³⁾		0	10	ns/V
T_A	Operating free-air temperature		-40	85	C

Notes

1. Absolute maximum of I_O must be observed.
2. Unused control inputs must be held HIGH or LOW to prevent them from floating.
- 3 As measured between 0.8V and 2.0V, $V_{DD} = 3.0V$.

Electrical Characteristics over Recommended Operating Free-Air Temperature Range

(unless otherwise noted)

DC Characteristics ($2.7V < V_{DD} \leq 3.6V$)

	Parameter	Conditions	V_{DD}	Min.	Typ.	Max.	Units
V_{IH}	HIGH Level Input Voltage		2.7 - 3.6	2.0			V
V_{IL}	LOW Level Input Voltage					0.8	
V_{OH}	HIGH Level Output Voltage	$I_{OH} = -100\mu A$		$V_{DD} - 0.2$			
		$I_{OH} = -12mA$	2.7	2.2			
		$I_{OH} = -18mA$	3.0	2.4			
		$I_{OH} = -24mA$		2.2			
V_{OL}	LOW Level Output Voltage	$I_{OL} = 100\mu A$	2.7 - 3.6			0.2	
		$I_{OL} = 12mA$	2.7			0.4	
		$I_{OL} = 18mA$	3.0			0.4	
		$I_{OL} = 24mA$				0.55	
I_I	Input Leakage Current	$V_I = 0.0V, V_I = 3.6V$	3.6			± 5.0	μA
I_{OZ}	3-STATE Output Leakage	$0 \leq V_O \leq 3.6V$ $V_I = V_{IH}$ or V_{IL}	2.7 - 3.6			± 10	
I_{OFF}	Power-OFF Leakage Current	$0 \leq (V_I, V_O) \leq 3.6V$	0			10	
I_{DD}	Quiescent Supply Current	$V_I = V_{DD}$ to GND	2.7 - 3.6			20	
		$V_{DD} \leq (V_I, V_O) \leq 3.6V$				± 20	
ΔI_{DD}	Increase in I_{DD} per input	$V_{IH} = V_{DD} - 0.6V$, Other inputs at V_{DD} or Gnd					

Electrical Characteristics over Recommended Operating Free-Air Temperature Range

(unless otherwise noted) (continued from previous page)

DC Characteristics ($2.3V \leq V_{DD} \leq 2.7V$)

	Parameters	Conditions	V_{DD}	Min.	Typ.	Max.	Units
V_{IH}	HIGH Level Input Voltage		2.3 - 2.7	1.6			V
V_{IL}	LOW Level Input Voltage					0.7	
V_{OH}	HIGH Level Output Voltage	$I_{OH} = -100\mu A$	2.3	$V_{DD} - 0.2$			
		$I_{OH} = -6mA$		2.0			
		$I_{OH} = -12mA$		1.8			
		$I_{OH} = -18mA$		1.7			
V_{OL}	LOW Level Output Voltage	$I_{OL} = 100\mu A$	2.3 - 2.7			0.2	
		$I_{OL} = 12mA$	2.3			0.4	
		$I_{OL} = 18mA$				0.6	
I_I	Input Leakage Current	$V_I = 0.0V, V_I = 2.7V$	2.7			± 5.0	
I_{OZ}	3-STATE Output Leakage	$0 \leq V_O \leq 3.6V$ $V_I = V_{IH}$ or V_{IL}	2.3 - 2.7			± 10	
I_{OFF}	Power-OFF Leakage Current	$0 \leq (V_I, V_O) \leq 3.6V$	0			10	
I_{DD}	Quiescent Supply Current	$V_I = V_{DD}$ or GND	2.3 - 2.7			20	
		$V_{DD} \leq (V_I, V_O) \leq 3.6V$				± 20	

DC Characteristics ($1.8V \leq V_{DD} \leq 2.3V$)

	Parameters	Conditions	V_{DD}	Min.	Typ.	Max.	Units	
V_{IH}	HIGH Level Input Voltage		1.8 - 2.3	$0.7 \times V_{DD}$			V	
V_{IL}	LOW Level Input Voltage					$0.2 \times V_{DD}$		
V_{OH}	HIGH Level Output Voltage	$I_{OH} = -100 \mu A$	1.8	$V_{DD} - 0.2$				
		$I_{OH} = -6 mA$		1.4				
V_{OL}	LOW Level Output Voltage	$I_{OL} = 100 \mu A$						0.2
		$I_{OL} = 6 mA$						0.3
I_I	Input Leakage Current	$V_I = 0.0V, V_I = 1.8V$					± 5.0	
I_{OZ}	3-STATE Output Leakage	$0 \leq V_O \leq 3.6V$ $V_I = V_{IH}$ or V_{IL}					± 10	
I_{OFF}	Power-OFF Leakage Current	$0 \leq (V_I, V_O) \leq 3.6V$	0			10	μA	
I_{DD}	Quiescent Supply Current	$V_I = V_{DD}$ or GND	1.8			20		
		$V_{DD} \leq (V_I, V_O) \leq 3.6V$	1.8			± 20		

AC Electrical Characteristics⁽¹⁾

Symbol	Parameter	TA = -40°C to +85°C, CL = 30pF, RL = 500Ω						Units
		VDD = 3.3V ±0.3V		VDD = 2.5V ±0.2V		VDD = 1.8V		
		Min.	Max.	Min.	Max.	Min.	Max.	
tPHL, tPLH	Prop Delay	0.8	2.5	1.0	3.0	1.5	5.0	ns
tPZL, tPZH	Output Enable Time	0.8	3.5	1.0	4.1	1.5	6.5	
tPLZ, tPHZ	Output Disable Time	0.8	3.5	1.0	3.8	1.5	5.0	
tOSHL tOSLH	Output to Output Skew ⁽²⁾		0.5		0.5		0.5	

Notes

- For CL = 50pF add approximately 300ps to AC maximum specification
- Skew is defined as the absolute value of the difference between the actual propagation delay for any two separate outputs of the same device. The specification applies to any outputs switching in the same direction, either HIGH or LOW (tOSHL) or LOW to HIGH (tOSLH).

Dynamic Switching Characteristics

Symbol	Parameter	Conditions	VDD	TA = +25°C Typical	Units
VOLP	Quiet Output Dynamic Peak VOL	CL = 50pF, VIH = VDD, VIL = 0V	1.8	0.25	V
			2.5	0.6	
			3.3	0.8	
VOLV	Quiet Output Dynamic Valley VOL	CL = 50pF, VIH = VDD, VIL = 0V	1.8	-0.25	V
			2.5	-0.6	
			3.3	-0.8	
VOHV	Quiet Output Dynamic Valley VOH	CL = 50pF, VIH = VDD, VIL = 0V	1.8	1.5	V
			2.5	1.9	
			3.3	2.2	

Capacitance

Symbol	Parameter	Conditions	TA = +25°C Typical	Units
CIN	Input Capacitance	VDD = 1.8V, 2.5V or 3.3V, V1 = 0V or VDD	6	pF
COUT	Output Capacitance	V1 = 0V or VDD, VDD = 1.8V, 2.5V or 3.3V	7	
CPD	Power Dissipation Capacitance	V1 = 0V or VDD, F = 10MHz VDD = 1.8V, 2.5V or 3.3V	20	

Test Circuits and Switching Waveforms

Parameter Measurement Information ($V_{DD} = 1.8V - 3.6V$)

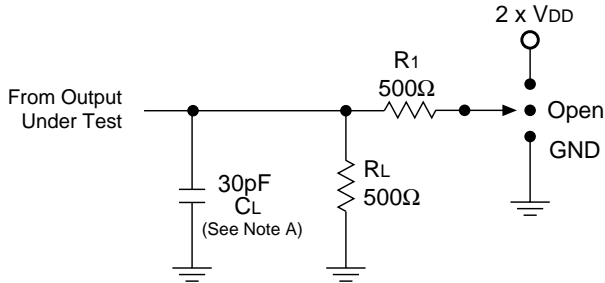

Switch Position

Test	S1
t_{pd}	Open
t_{PLZ}/t_{PZL}	$2 \times V_{DD}$
t_{PHZ}/t_{PZH}	GND

Pulse Width

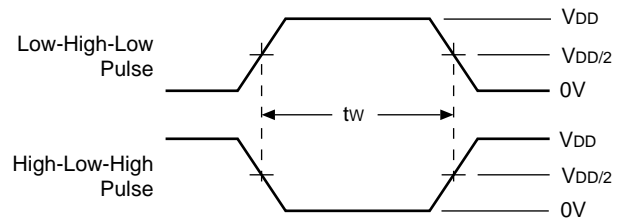

Setup, Hold, and Release Timing

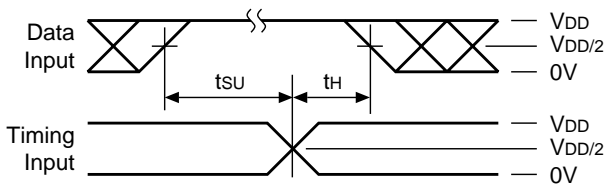

Propagaton Delay

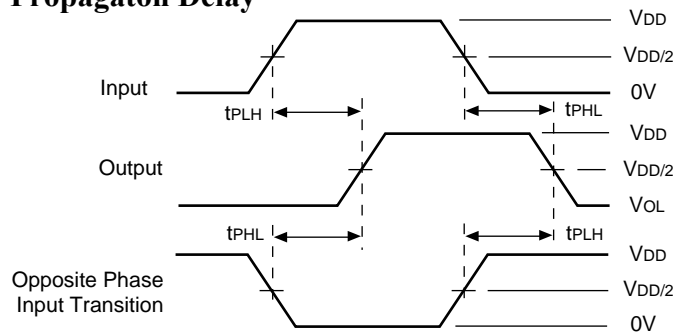

Notes:

- C_L includes probe and jig capacitance.
- Waveform 1 is for an output with internal conditions such that the output is LOW except when disabled by the output control. Waveform 2 is for an output with internal conditions such that the output is HIGH except when disabled by the output control.
- All input pulses are supplied by generators having the following characteristics: $PRR \leq 10 \text{ MHz}$, $Z_O = 50\Omega$, $t_r \leq 2\text{ns}$, $t_f \leq 2\text{ns}$, **measured from 10% to 90%, unless otherwise specified.**
- The outputs are measured one at a time with one transition per measurement.

Enable Disable Timing

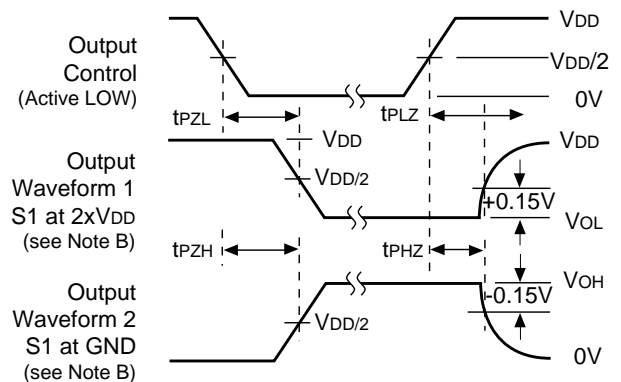

Packaging Mechanical: 48-pin TSSOP (A)

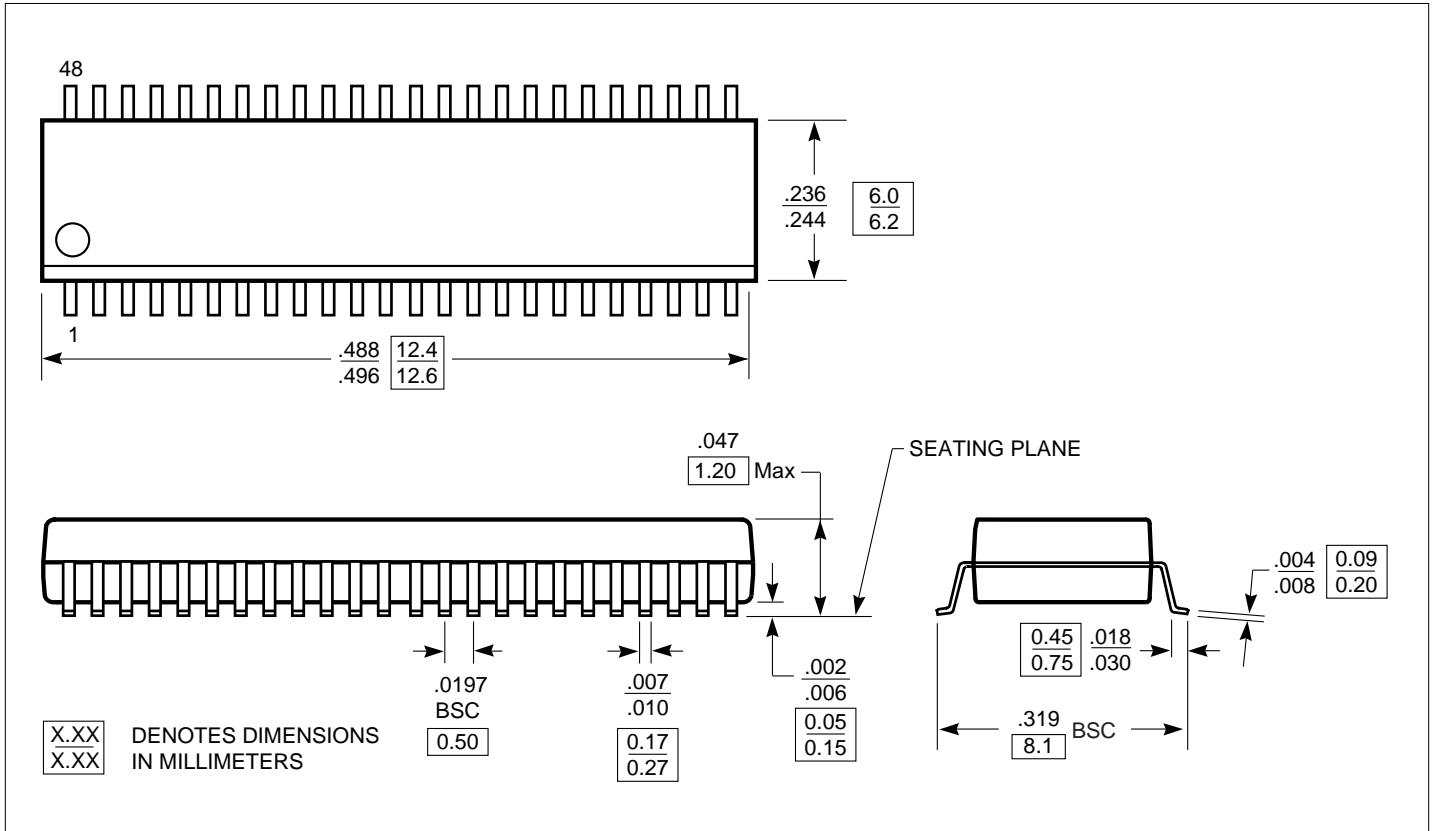

Ordering Information

Ordering Code	Package Code	Package Description
PI74VCX16244A	A	48-pin TSSOP
PI74VCX16244AE	A	Pb-free & Green, 48-pin TSSOP

Notes:

- Thermal characteristics can be found on the company web site at www.pericom.com/packaging/