



# EMIF08-2005QEJ

IPAD.™

## EMI FILTER INCLUDING ESD PROTECTION

### APPLICATIONS:

Where EMI filtering in ESD sensitive equipment is required :

- Computers and printer
- Communication systems
- Mobile phones

### DESCRIPTION

The EMIF08-2005QEJ is a highly integrated device designed to suppress EMI/RFI noise in all systems subjected to electromagnetic interferences. Additionally, the EMIF08-2005QEJ filter includes an ESD protection circuitry which prevents destruction when subjected to ESD discharge up to 15kV.

### BENEFITS

- EMI symmetrical low-pass filter
- Low PCB space consuming: 9 mm<sup>2</sup>
- Very thin package < 1 mm
- High reliability offered by monolithic integration

### COMPLIES WITH THE FOLLOWING STANDARDS:

IEC61000-4-2:

15kV (air discharge)  
8 kV (contact discharge)

MIL STD 883E - Method 3015-7 Class 3:

25kV (human body test)

### BASIC CELL CONFIGURATION

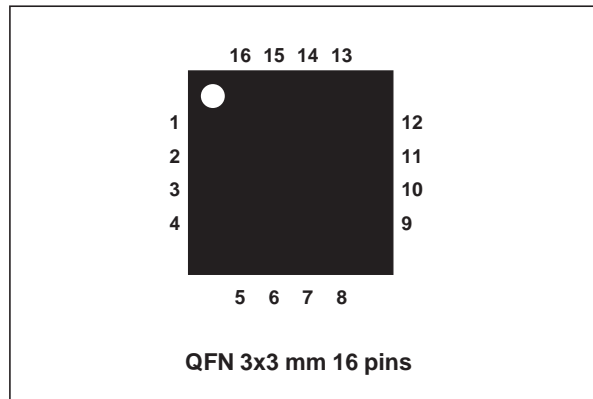
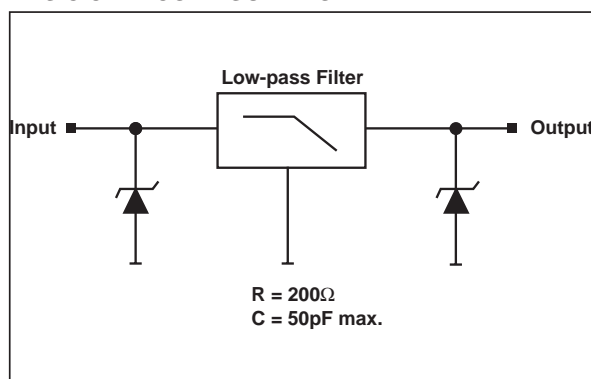

### PIN CONFIGURATION

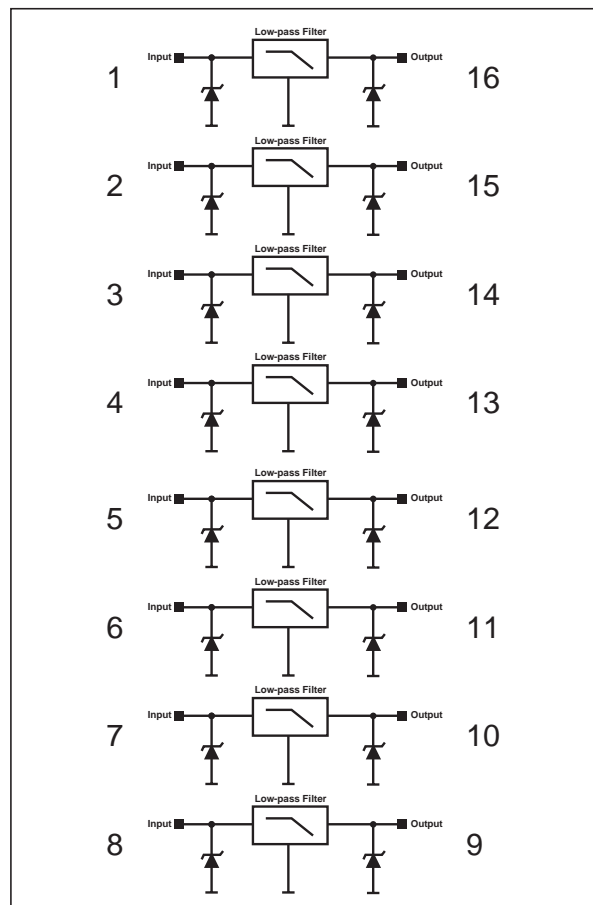

™ : IPAD is a trademark of STMicroelectronics.

December 2002 - Ed: 2A

# EMIF08-2005QEJ

## ABSOLUTE RATINGS (T<sub>amb</sub> = 25°C)

Symbol	Parameter and test conditions		Value	Unit
V <sub>PP</sub>	ESD discharge	EC61000-4-2 air discharge IEC61000-4-2 contact discharge	± 15 ± 8	kV
T <sub>j</sub>	Junction temperature		125	°C
T <sub>stg</sub>	Storage temperature range		-55 + 150	°C
T <sub>L</sub>	Maximum lead temperature for soldering		260	°C

## ELECTRICAL CHARACTERISTICS (T<sub>amb</sub> = 25°C)

Symbol	Parameter
V <sub>BR</sub>	Breakdown voltage
I <sub>RM</sub>	Leakage current @ V <sub>RM</sub>
V <sub>RM</sub>	Stand-off voltage
V <sub>CL</sub>	Clamping voltage
I <sub>PP</sub>	Peak pulse current
αT	Voltage temperature coefficient
V <sub>F</sub>	Forward voltage drop

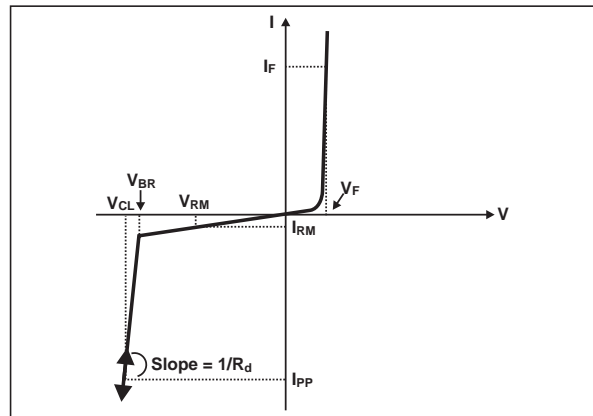

Symbol	Test conditions	Min.	Typ.	Max.	Unit
V <sub>BR</sub>	I <sub>R</sub> = 1 mA	6	8	10	V
I <sub>RM</sub>	V <sub>RM</sub> = 3V per line			500	μA
R <sub>d</sub>	I <sub>PP</sub> = 10A, t <sub>p</sub> = 2.5μs (see note 1)		1		Ω
R <sub>i/O</sub>		180	200	220	Ω
C <sub>in</sub>	V <sub>bias</sub> = 0V    F = 1MHz    V <sub>osc</sub> = 30mV		45	50	pF

Fig. 1: Filtering behavior.

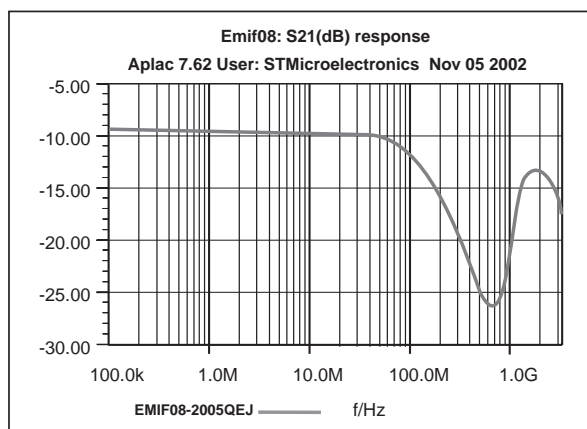
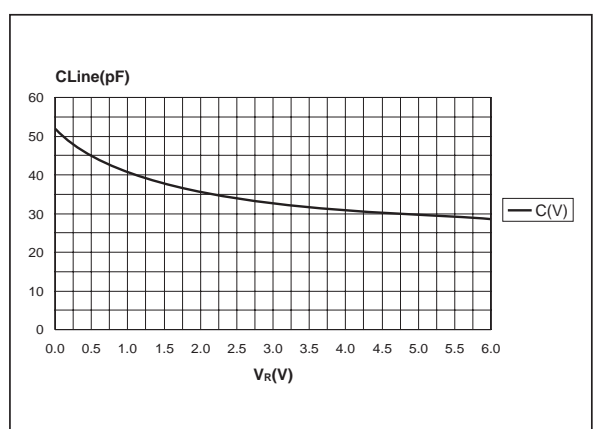
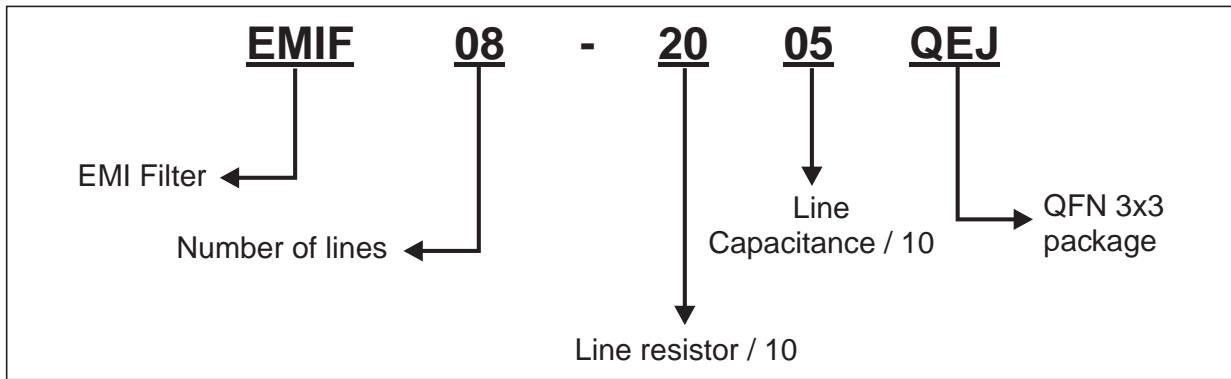

Fig. 2: Capacitance versus reverse applied voltage.



ORDER CODE



PACKAGE OUTLINE DIMENSIONS

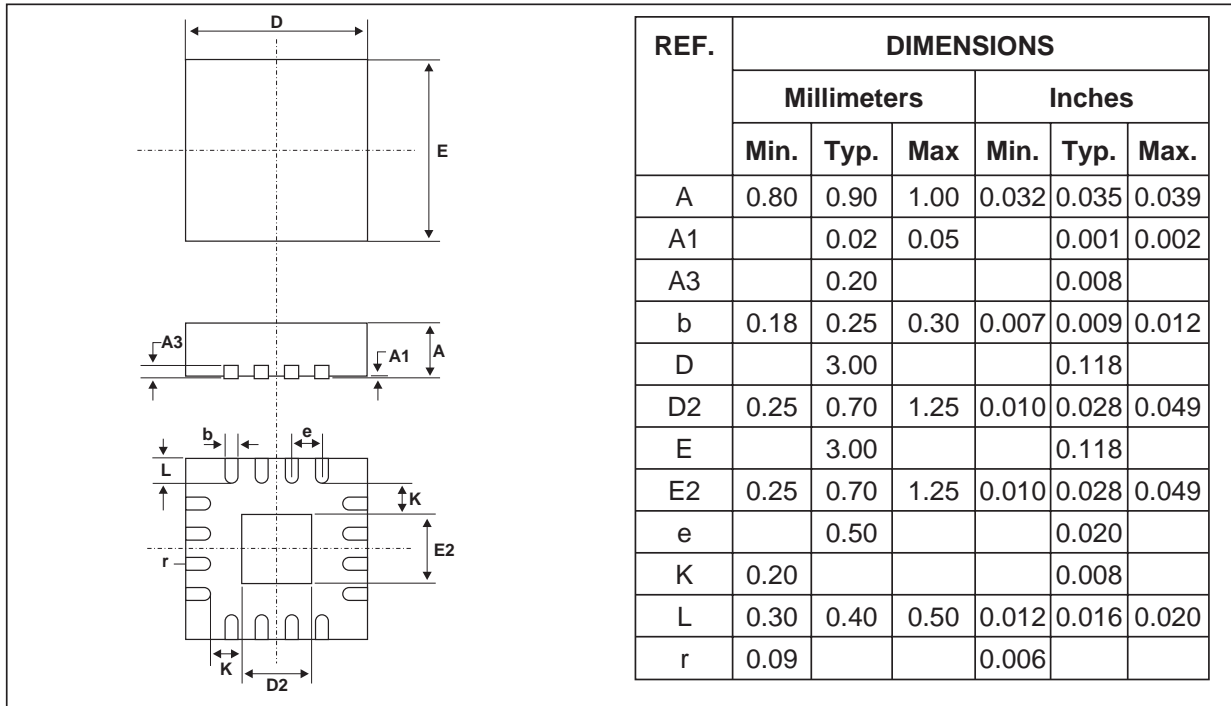

FOOT PRINT DIMENSIONS (in millimeters)

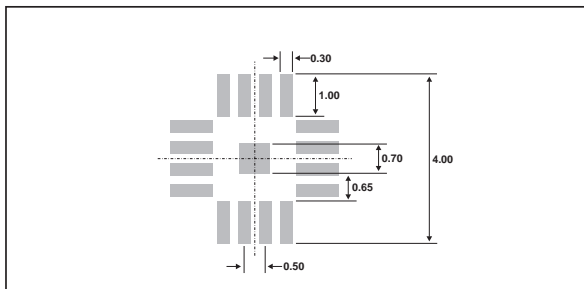

OTHER INFORMATION

Ordering code	Marking	Package	Weight	Base qty	Delivery mode
EMIF08-2005QEJ	EM08	QFN 3x3 16 pins	22.1 mg	3000	Tape & reel

Information furnished is believed to be accurate and reliable. However, STMicroelectronics assumes no responsibility for the consequences of use of such information nor for any infringement of patents or other rights of third parties which may result from its use. No license is granted by implication or otherwise under any patent or patent rights of STMicroelectronics. Specifications mentioned in this publication are subject to change without notice. This publication supersedes and replaces all information previously supplied. STMicroelectronics products are not authorized for use as critical components in life support devices or systems without express written approval of STMicroelectronics.

The ST logo is a registered trademark of STMicroelectronics  
 © 2002 STMicroelectronics - Printed in Italy - All rights reserved.  
 STMicroelectronics GROUP OF COMPANIES  
 Australia - Brazil - Canada - China - Finland - France - Germany  
 Hong Kong - India - Israel - Italy - Japan - Malaysia - Malta - Morocco - Singapore  
 Spain - Sweden - Switzerland - United Kingdom - United States.

<http://www.st.com>

