

TOSHIBA TRANSISTOR SILICON PNP EPITAXIAL TYPE (PCT PROCESS)

RN2901, RN2902, RN2903, RN2904, RN2905, RN2906

Unit in mm

SWITCHING, INVERTER CIRCUIT, INTERFACE CIRCUIT AND DRIVER CIRCUIT APPLICATIONS.

- Including Two Devices in US6 (Ultra Super Mini Type with 6 leads)
- With Built-in Bias Resistors
- Simplify Circuit Design
- Reduce a Quantity of Parts and Manufacturing Process
- Complementary to RN1901~RN1906

EQUIVALENT CIRCUIT AND BIAS RESISTOR VALUES

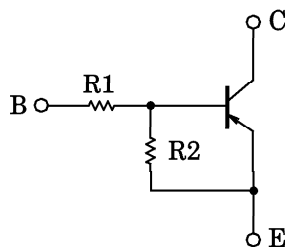

TYPE No.	R1 (kΩ)	R2 (kΩ)
RN2901	4.7	4.7
RN2902	10	10
RN2903	22	22
RN2904	47	47
RN2905	2.2	47
RN2906	4.7	47

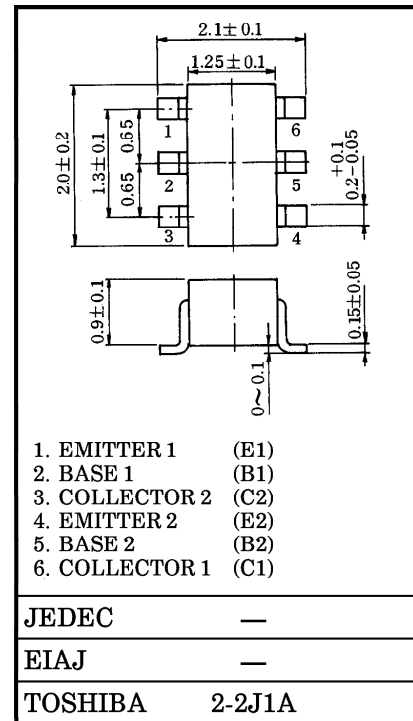

EQUIVALENT CIRCUIT (TOP VIEW)

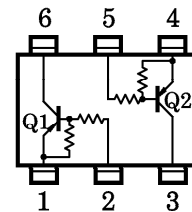

MAXIMUM RATINGS (Ta = 25°C) (Q1, Q2 COMMON)

CHARACTERISTIC		SYMBOL	RATING	UNIT
Collector-Base Voltage	RN2901~2906	V _{CB0}	-50	V
Collector-Emitter Voltage		V _{CEO}	-50	V
Emitter-Base Voltage	RN2901~2904	V _{EBO}	-10	V
	RN2905~2906		-5	
Collector Current	RN2901~2906	I _C	-100	mA
Collector Power Dissipation		P _C *	200	mW
Junction Temperature		T _j	150	°C
Storage Temperature Range		T _{stg}	-55~150	°C

* : Total Rating

961001EAA2

● TOSHIBA is continually working to improve the quality and the reliability of its products. Nevertheless, semiconductor devices in general can malfunction or fail due to their inherent electrical sensitivity and vulnerability to physical stress. It is the responsibility of the buyer, when utilizing TOSHIBA products, to observe standards of safety, and to avoid situations in which a malfunction or failure of a TOSHIBA product could cause loss of human life, bodily injury or damage to property. In developing your designs, please ensure that TOSHIBA products are used within specified operating ranges as set forth in the most recent products specifications. Also, please keep in mind the precautions and conditions set forth in the TOSHIBA Semiconductor Reliability Handbook.

ELECTRICAL CHARACTERISTICS (Ta = 25°C) (Q1, Q2 COMMON)

CHARACTERISTIC		SYMBOL	TEST CONDITION	MIN.	TYP.	MAX.	UNIT
Collector Cut-off Current	RN2901~2906	ICBO	V _{CB} = -50V, I _E = 0	—	—	-100	nA
		ICEO	V _{CE} = -50V, I _B = 0	—	—	-500	
Emitter Cut-off Current	RN2901	I _{EBO}	V _{EB} = -10V, I _C = 0	-0.82	—	-1.52	mA
	RN2902			-0.38	—	-0.71	
	RN2903			-0.17	—	-0.33	
	RN2904		-0.082	—	-0.15		
	RN2905		V _{EB} = -5V, I _C = 0	-0.078	—	-0.145	
	RN2906			-0.074	—	-0.138	
DC Current Gain	RN2901	h _{FE}	V _{CE} = -5V, I _C = -10mA	30	—	—	
	RN2902			50	—	—	
	RN2903			70	—	—	
	RN2904			80	—	—	
	RN2905			80	—	—	
	RN2906			80	—	—	
Collector-Emitter Saturation Voltage	RN2901~2906	V _{CE (sat)}	I _C = -5mA I _B = -0.25mA	—	-0.1	-0.3	V
Input Voltage (ON)	RN2901	V _{I (ON)}	V _{CE} = -0.2V I _C = -5mA	-1.1	—	-2.0	V
	RN2902			-1.2	—	-2.4	
	RN2903			-1.3	—	-3.0	
	RN2904			-1.5	—	-5.0	
	RN2905			-0.6	—	-1.1	
	RN2906			-0.7	—	-1.3	
Input Voltage (OFF)	RN2901~2904	V _{I (OFF)}	V _{CE} = -5V I _C = -0.1mA	-1.0	—	-1.5	V
	RN2905, 2906			-0.5	—	-0.8	
Transition Frequency	RN2901~2906	f _T	V _{CE} = -10V, I _C = -5mA	—	200	—	MHz
Collector Output Capacitance	RN2901~2906	C _{ob}	V _{CB} = -10V, I _E = 0, f = 1MHz	—	3	6	pF
Input Resistor	RN2901	R1		3.29	4.7	6.11	kΩ
	RN2902			7	10	13	
	RN2903			15.4	22	28.6	
	RN2904			32.9	47	61.1	
	RN2905			1.54	2.2	2.86	
	RN2906			3.29	4.7	6.11	
Resistor Ratio	RN2901~2904	R1 / R2		0.9	1.0	1.1	
	RN2905			0.0421	0.0468	0.0515	
	RN2906			0.09	0.1	0.11	

961001EAA2'

- The information contained herein is presented only as a guide for the applications of our products. No responsibility is assumed by TOSHIBA CORPORATION for any infringements of intellectual property or other rights of the third parties which may result from its use. No license is granted by implication or otherwise under any intellectual property or other rights of TOSHIBA CORPORATION or others.
- The information contained herein is subject to change without notice.

(Q1, Q2 COMMON)

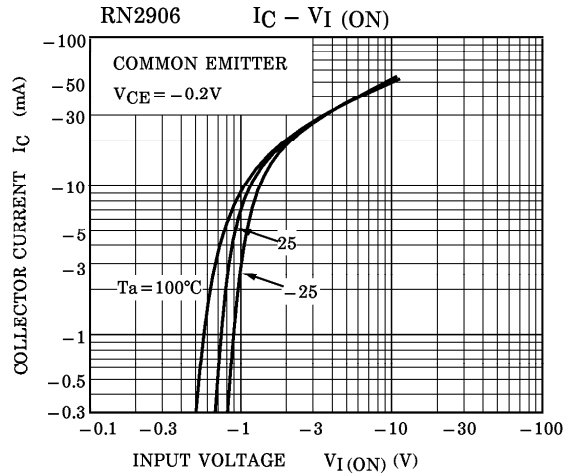
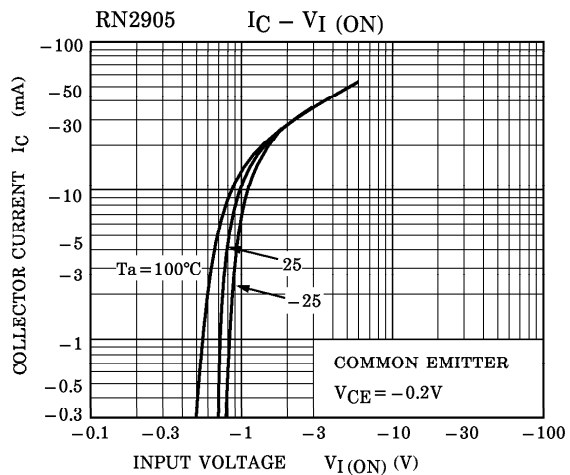
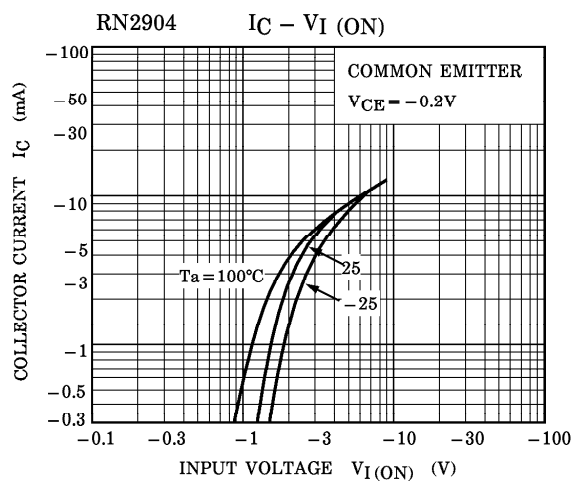
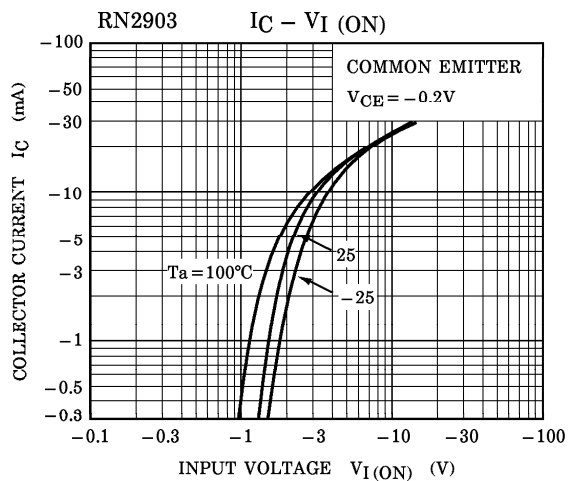
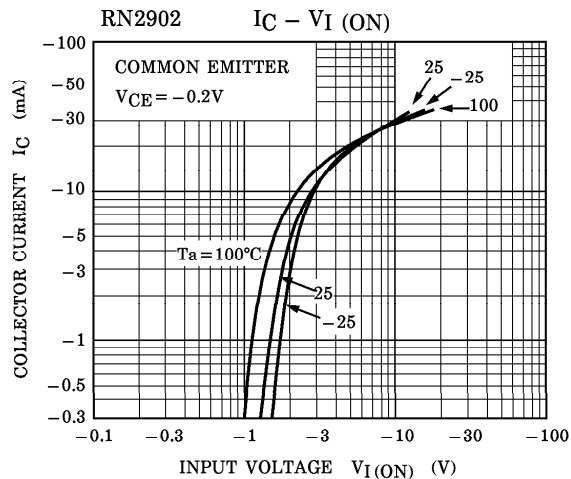
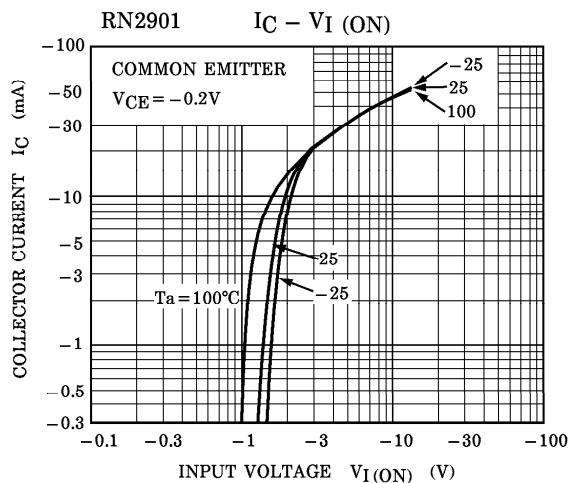

(Q1, Q2 COMMON)

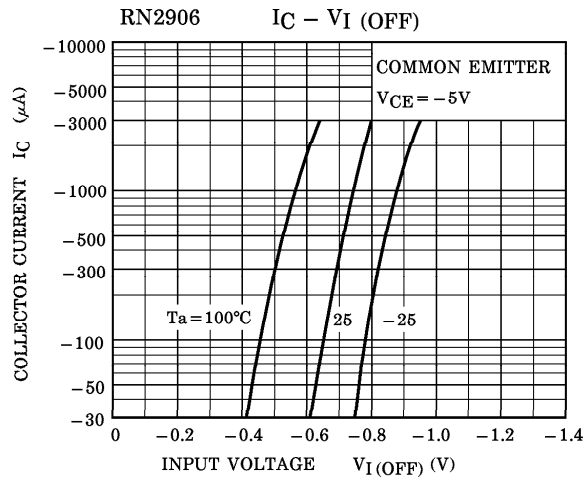
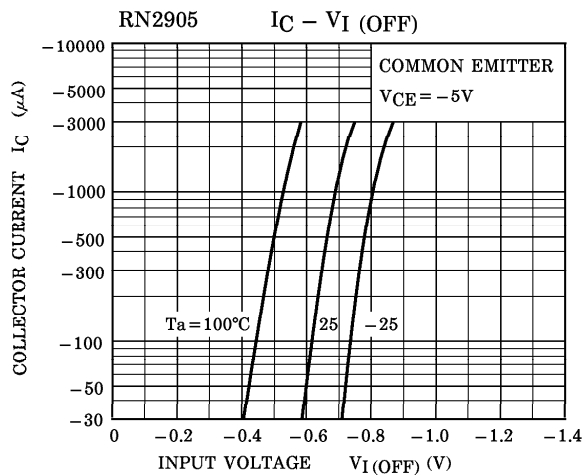
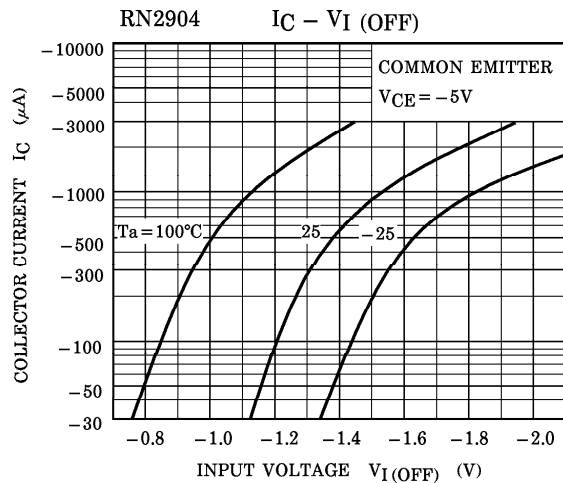
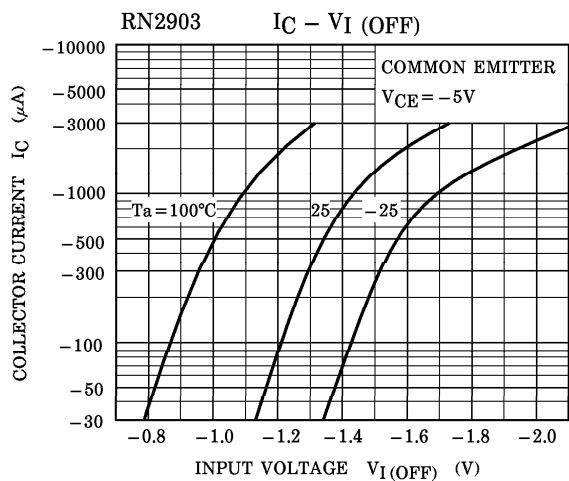
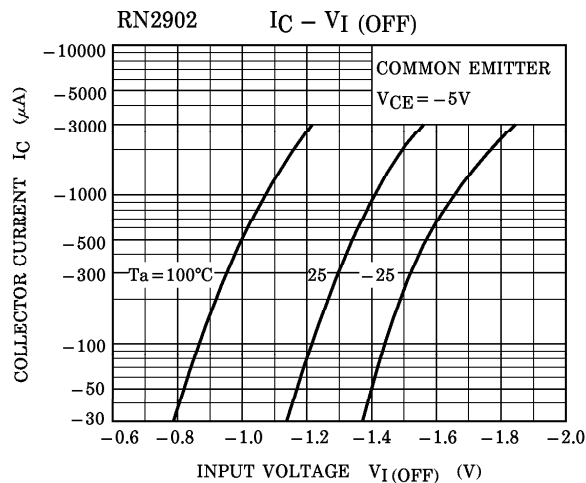
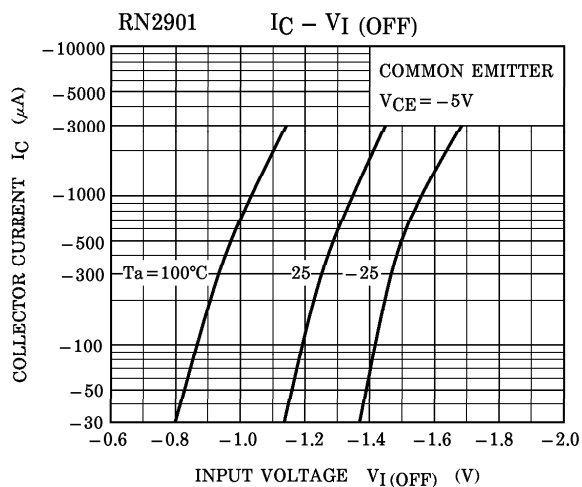

(Q1, Q2 COMMON)

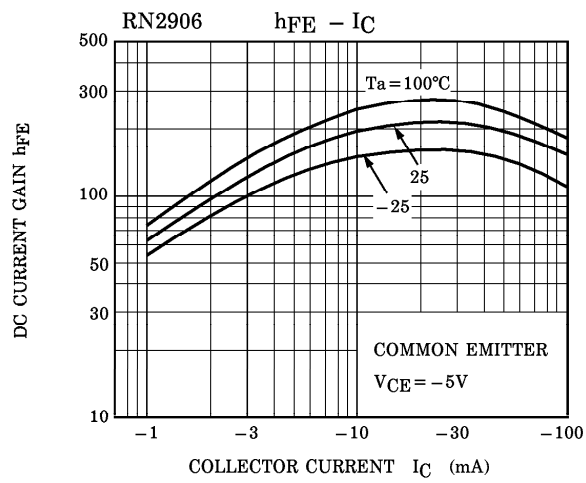
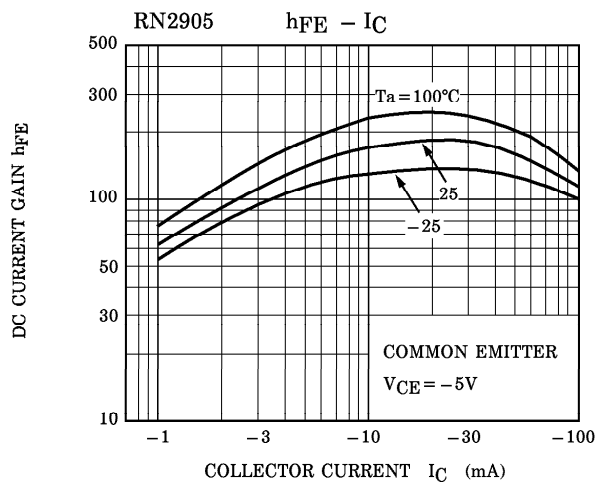
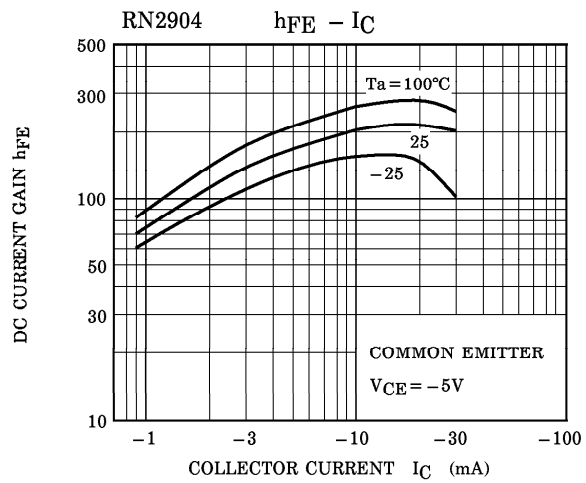
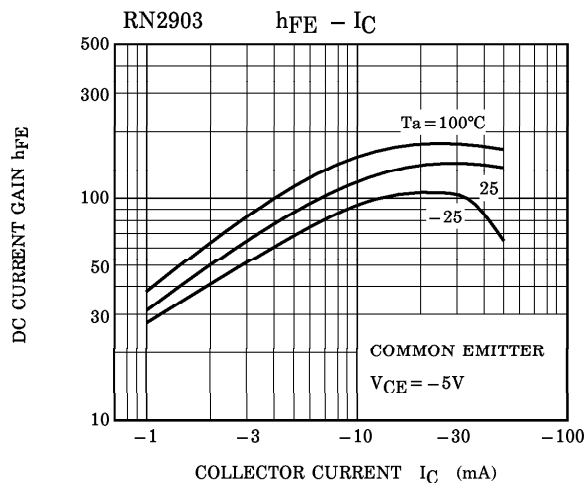
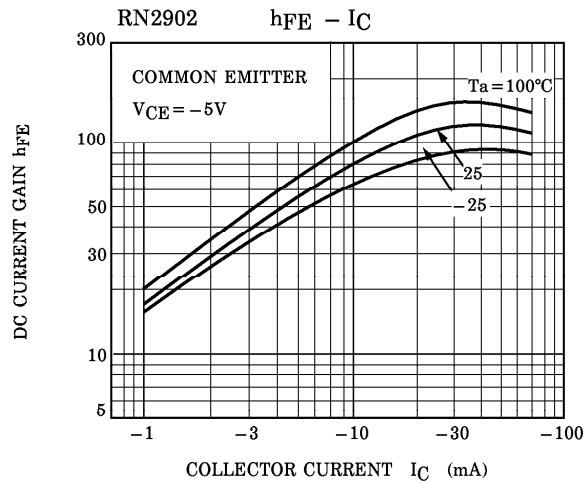
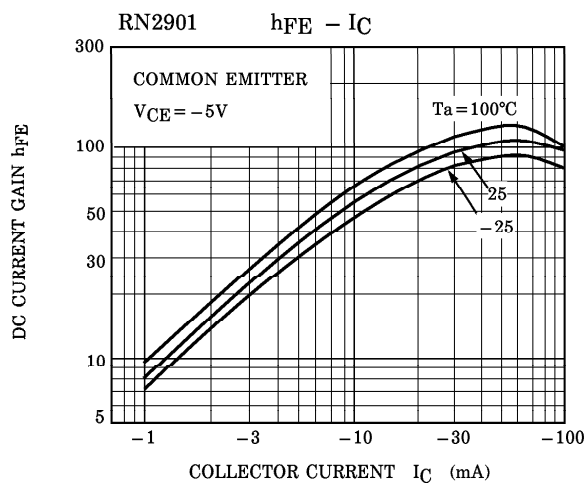

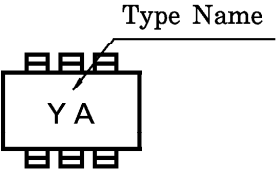
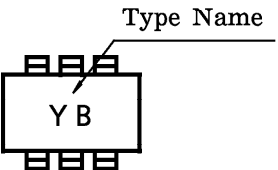
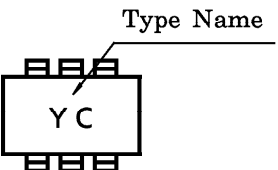
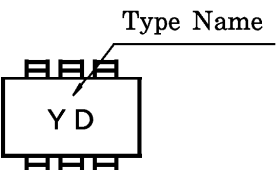
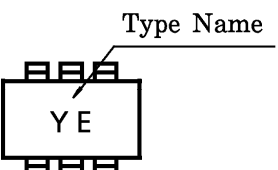
TYPE NAME	MARKING
RN2901	
RN2902	
RN2903	
RN2904	
RN2905	
RN2906	