

**Features**

- Single power supply: 2.4V~3.3V
- Low standby current: 1μA (Typ.) at VDD=3V
- Speaker or direct piezo application
- Sound output: one Main Tone plus two Fighting Sounds (1,2)
- Two direct LED drive outputs (The flash rate depends on the sound speed)
- Option mode selection: normal mode or auto mode (bonding option)
- Minimum external components

**General Description**

The HT2830 is a CMOS LSI chip designed for use in sound effect products. It is a body structure including tone circuit, noise circuit, an up-down counter, and other control logic to generate various sounds such as JET plane, motorcycle, helicopter, train, and so forth. Fea-

tures from the customer's sound samples can be analyzed and programmed into an internal ROM by changing a mask layer during device fabrication. The HT2830 is suitable for various toy applications.

**Pin Assignment**

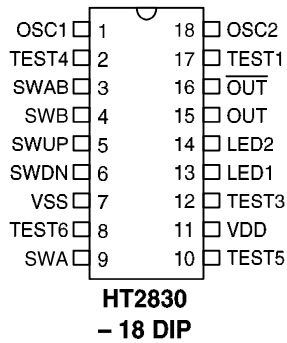

**Block Diagram**

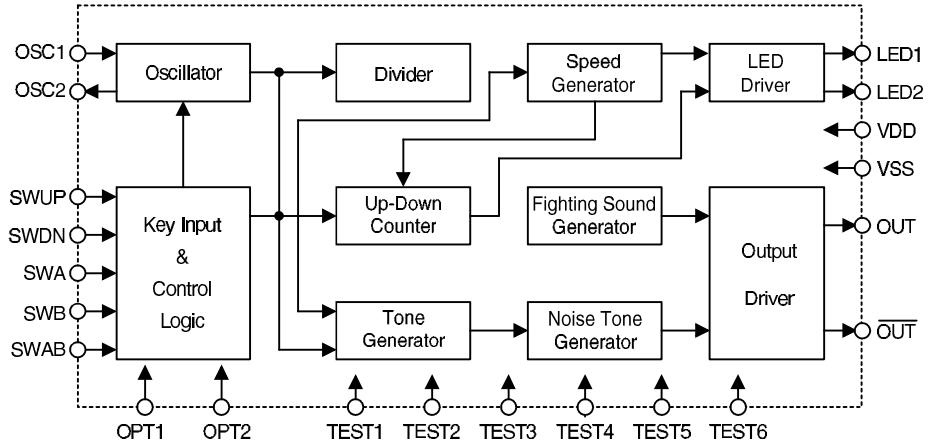

**Pad Assignment**

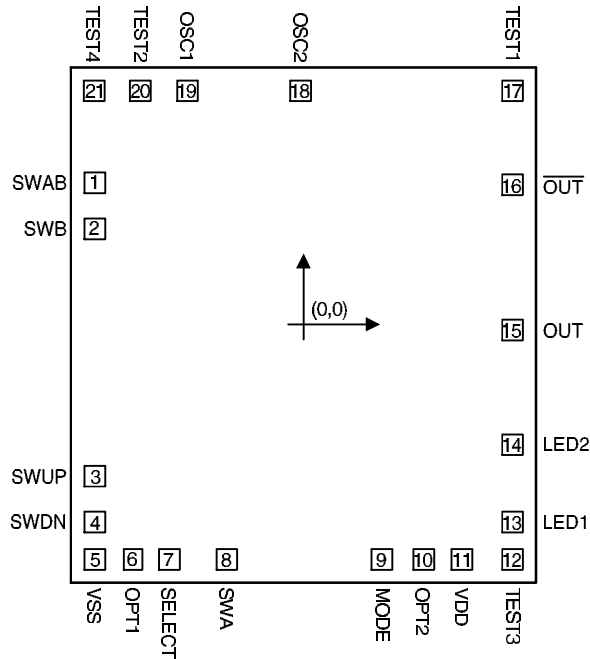

Chip size:  $97 \times 107 \text{ (mil)}^2$

\* The IC substrate should be connected to VDD in the PCB layout artwork.

**Pad Coordinates**

Unit: mil

Pad No.	X	Y	Pad No.	X	Y
1	-36.13	24.57	12	36.01	-40.46
2	-36.13	16.62	13	36.01	-33.96
3	-36.13	-26.09	14	36.01	-20.66
4	-36.13	-33.96	15	36.01	-0.88
5	-36.13	-40.46	16	36.01	24.24
6	-29.70	-40.46	17	36.01	40.46
7	-23.24	-40.46	18	-0.58	40.46
8	-13.35	-40.46	19	-20.13	40.46
9	13.46	-40.46	20	-28.24	40.46
10	20.66	-40.46	21	-36.25	40.46
11	27.18	-40.46			

**Pad Description**

Pad No.	Pad Name	I/O	Description
1	SWAB	I	Fighting sound 1/2 toggle input, low active
2	SWB	I	Fighting sound 2 input, low active
3	SWUP	I	Main tone up input, low active
4	SWDN	I	Main tone down input, low active
5	VSS	—	Negative power supply, GND
6	OPT1	I	Main tone option
7	TEST6	I	For IC test only
8	SWA	I	Fighting sound 1 input, low active
9	TEST5	I	For IC test only
10	OPT2	I	Normal mode/auto mode option
11	VDD	—	Positive power supply
12	TEST3	O	For IC test only
13	LED1	O	LED flash output
14	LED2	O	LED flash output
15	OUT	O	Sound output
16	$\overline{\text{OUT}}$	O	Sound output, out of phase to pad 15
17	TEST1	O	For IC test only
18	OSC2	O	Oscillator output
19	OSC1	I	Oscillator input

Pad No.	Pad Name	I/O	Description
20	TEST2	O	For IC test only
21	TEST4	I	For IC test only

- (1) OPT1: Bond pad 5 → Main Tone 1  
 Bond pad 6 → Main Tone 2
- (2) OPT2: Bond pad 10 → Auto Mode  
 Bond Pad 11 → Normal Mode

### Absolute Maximum Ratings\*

Supply Voltage ..... -0.3V to 5V      Storage Temperature..... -50°C to 125°C  
 Input Voltage.....  $V_{SS}-0.3V$  to  $V_{DD}+0.3V$       Operating Temperature..... 0°C to 70°C

\*Note: Stresses above those listed under “Absolute Maximum Ratings” may cause permanent damage to the device. These are stress ratings only. Functional operation of this device at these or any other conditions above those indicated in the operational sections of this specification is not implied and exposure to absolute maximum rating conditions for extended periods may affect device reliability.

### Electrical Characteristics

(Ta=25°C)

Symbol	Parameter	Test Conditions		Min.	Typ.	Max.	Unit
		V <sub>DD</sub>	Conditions				
V <sub>DD</sub>	Operating Voltage	—	—	2.4	3	3.3	V
I <sub>STB</sub>	Standby Current	3V	—	—	1	5	μA
I <sub>DD</sub>	Operating Current	3V	No load	—	—	150	μA
I <sub>OH</sub>	OUT Source Current	3V	V <sub>OH</sub> =2.5V	-2	—	—	mA
I <sub>OL1</sub>	OUT Sink Current	3V	V <sub>OL</sub> =0.5V	0.7	—	—	mA
I <sub>OL2</sub>	LED1 Sink Current	3V	V <sub>OL</sub> =1V	-8	—	—	mA
I <sub>OL3</sub>	LED2 Sink Current	3V	V <sub>OL</sub> =1V	-8	—	—	mA
V <sub>IH</sub>	“H” Input Voltage	3V	—	2.4	—	—	V
V <sub>OL</sub>	“L” Input Voltage	3V	—	—	—	0.6	V
F <sub>OSC</sub>	Oscillator Frequency	—	R <sub>OSC</sub> =62kΩ	—	256	—	kHz

**Timing Diagram & Application Circuit**

- Normal mode (1)

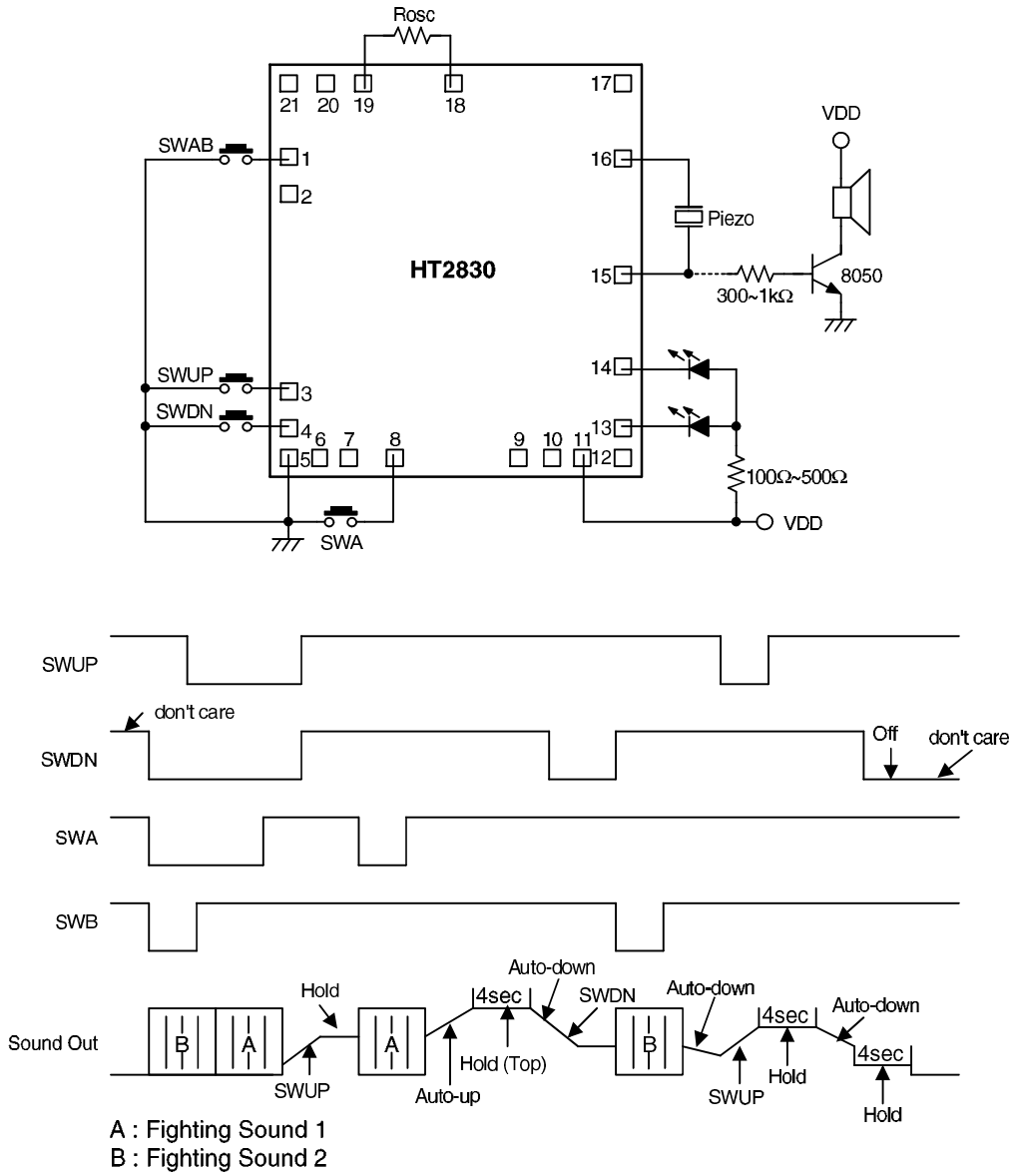





- Auto mode (1)

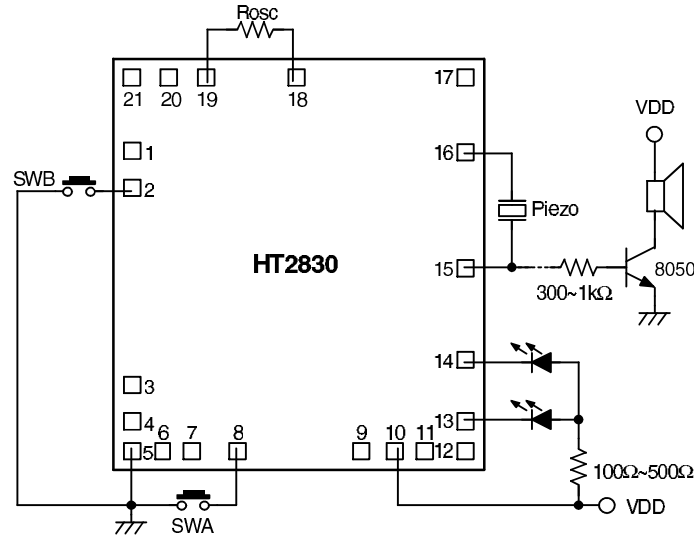

**Timing 1**

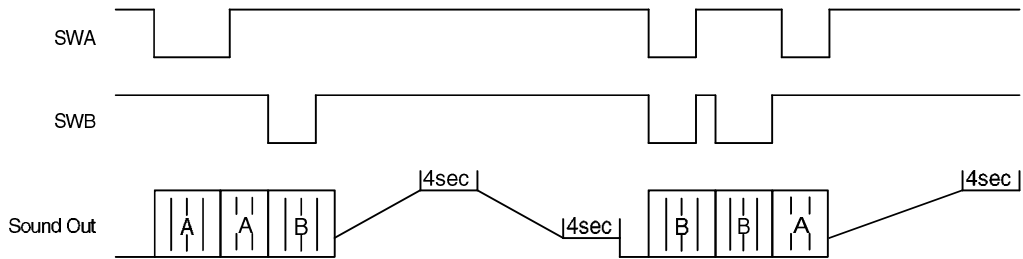

**Timing 2**

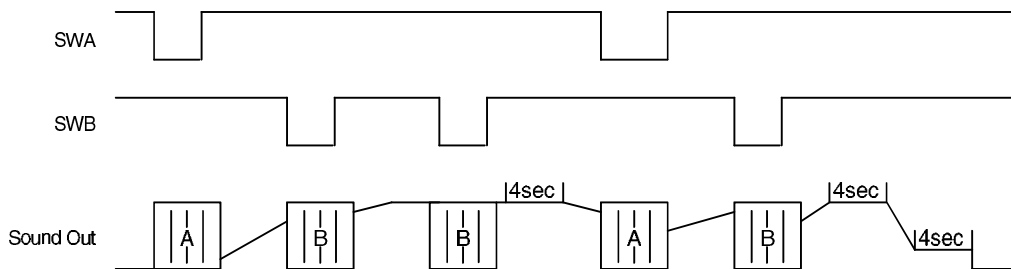

A : Fighting Sound 1  
 B : Fighting Sound 2



- Auto mode (2)

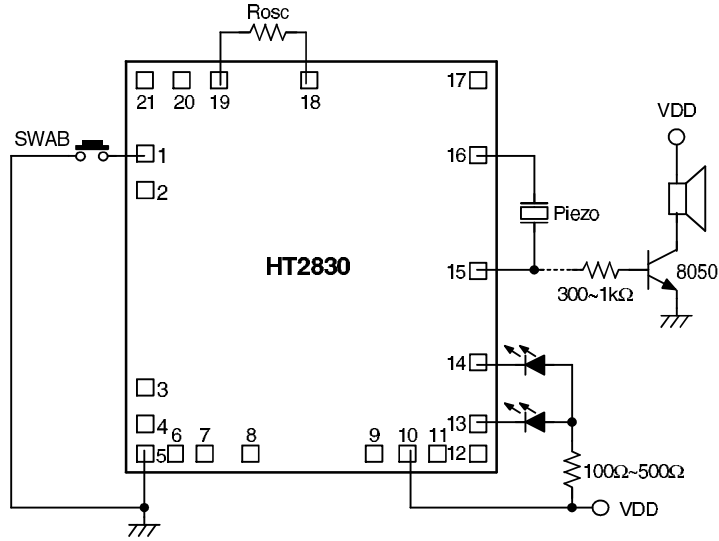

**Timing 1**

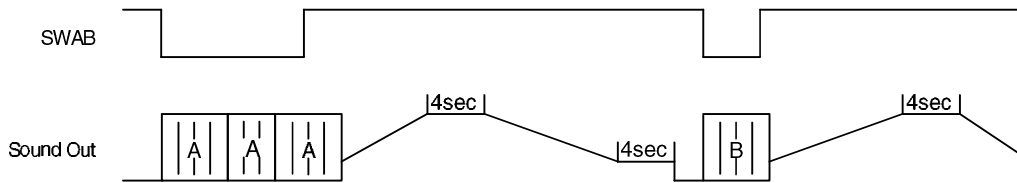

**Timing 2**

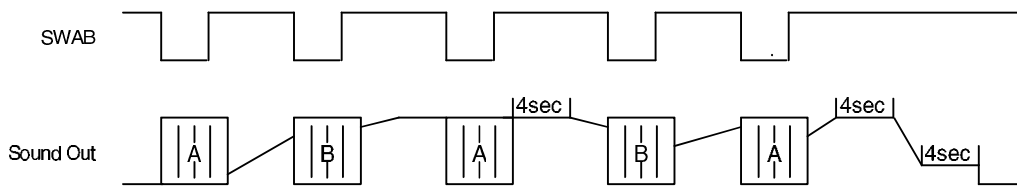

A : Fighting Sound 1  
 B : Fighting Sound 2

**Application Circuit (HT2830A — Jet Plane & Motorcycle)**

- Jet plane sound: Normal mode (1) Example

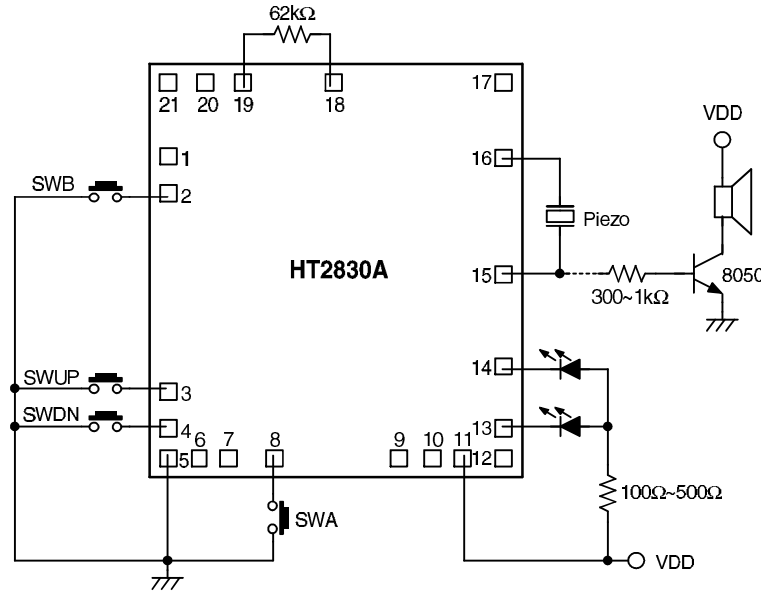

\* The IC substrate should be connected to VDD in PCB layout artwork.

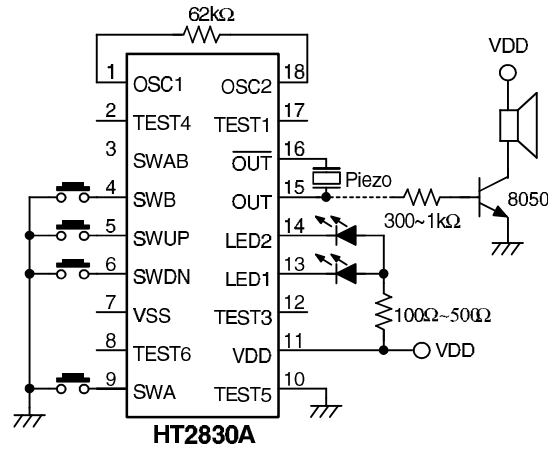

Main Tone: Jet Plane Sound  
 Fighting Sound 1: Machine Gun  
 Fighting Sound 2: Missile

• Motorcycle sound: Normal mode (1) Example

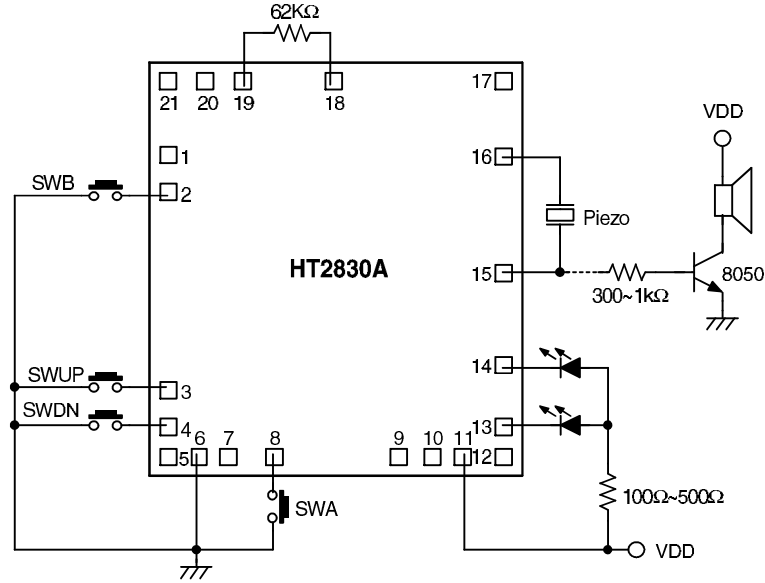

\* The IC substrate should be connected to VDD in PCB layout artwork.

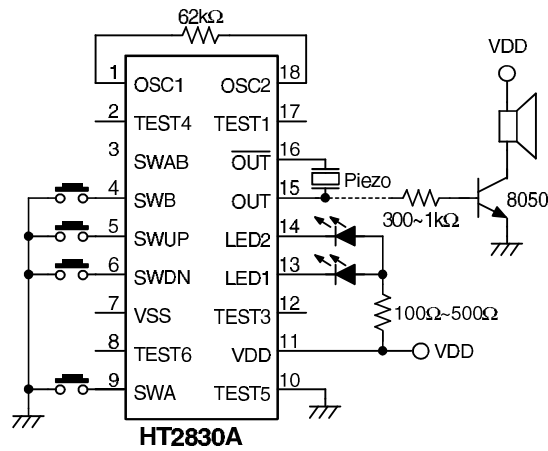

Main Tone : Motorcycle Sound  
 Fighting Sound 1 : Machine Gun  
 Fighting Sound 2 : Missile

Application Circuit (HT2830B — Helicopter Sound)

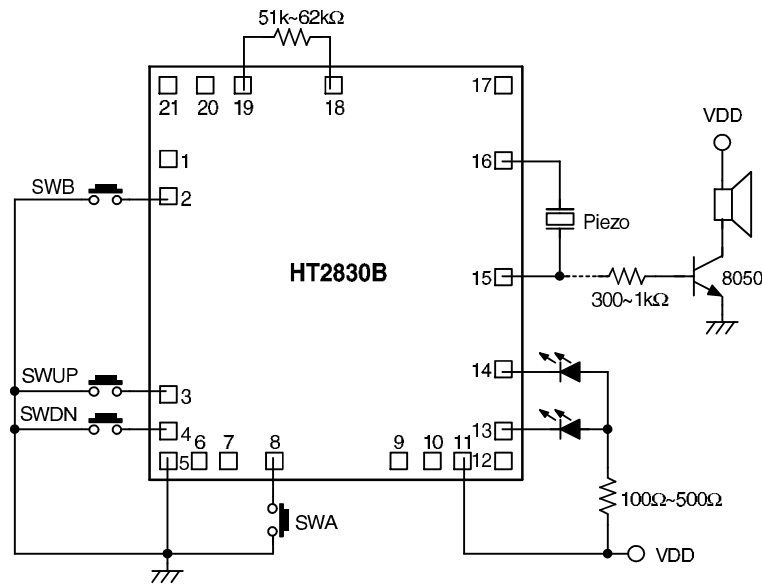

\* The IC substrate should be connected to VDD in PCB layout artwork.

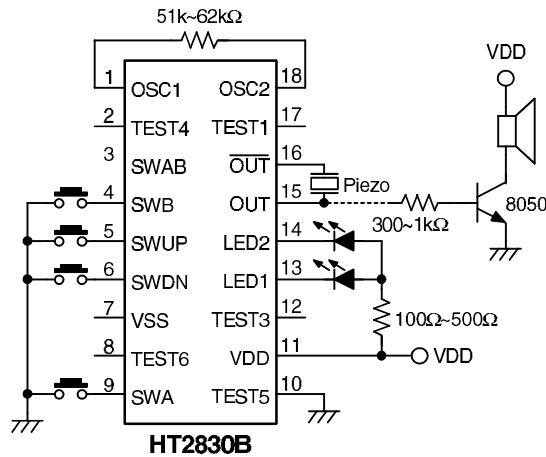

Main Tone: Helicopter Propeller Sound  
 Fighting Sound 1: Machine Gun  
 Fighting Sound 2: Missile

Application Circuit (HT2830C — Train Sound)

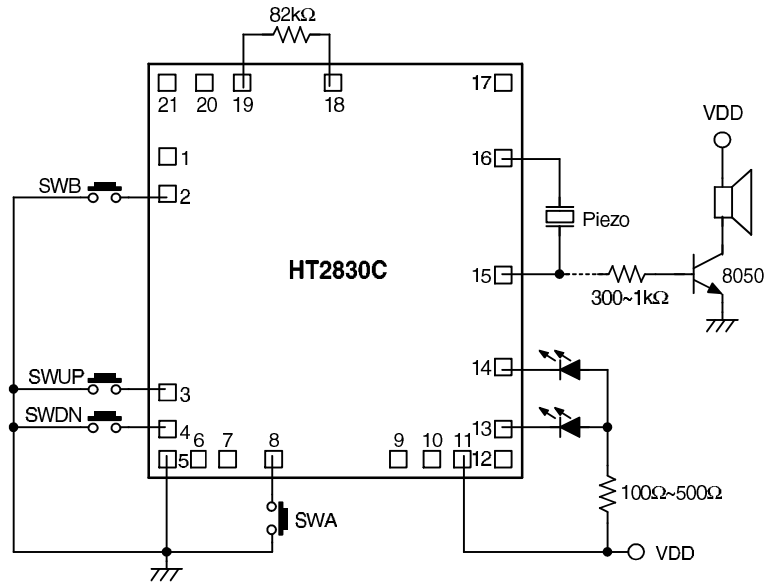

\* The IC substrate should be connected to VDD in PCB layout artwork.

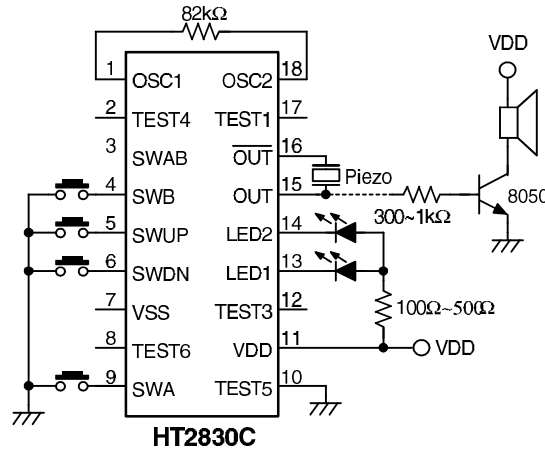

Main Tone : Train Sound  
 Fighting Sound 1 : Bell  
 Fighting Sound 2 : Horn

**Application Circuit (HT2830D — Jet Plane & Motorcycle)**

- Jet plane sound: Normal mode (1) Example

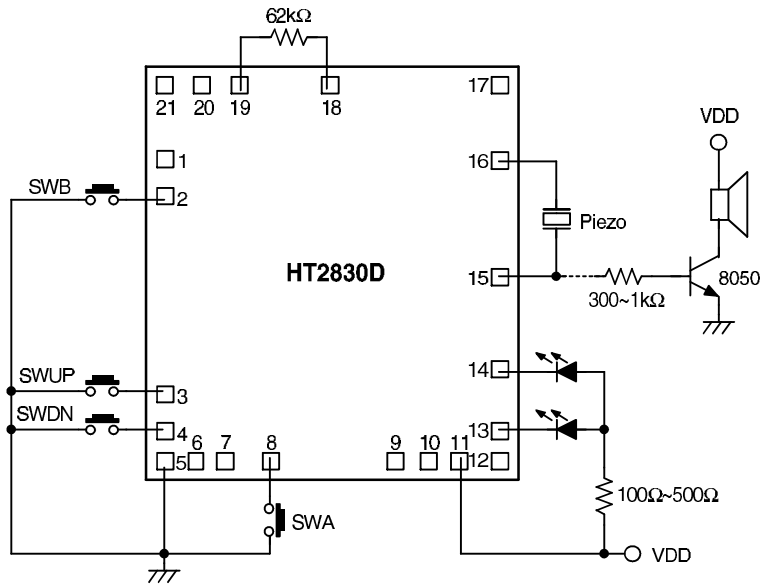

\* The IC substrate should be connected to VDD in PCB layout artwork.

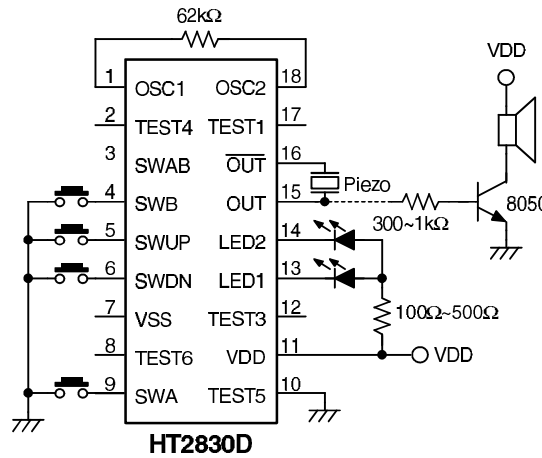

Main Tone: Jet plane Sound  
 Fighting Sound 1: Machine Gun  
 Fighting Sound 2: Missile

- Note: (1) The SWUP and SWDN keys are level hold trigger  
 (2) Power on auto play  
 (3) No auto-up and auto-down function

• Motorcycle sound: Normal mode (1) Example

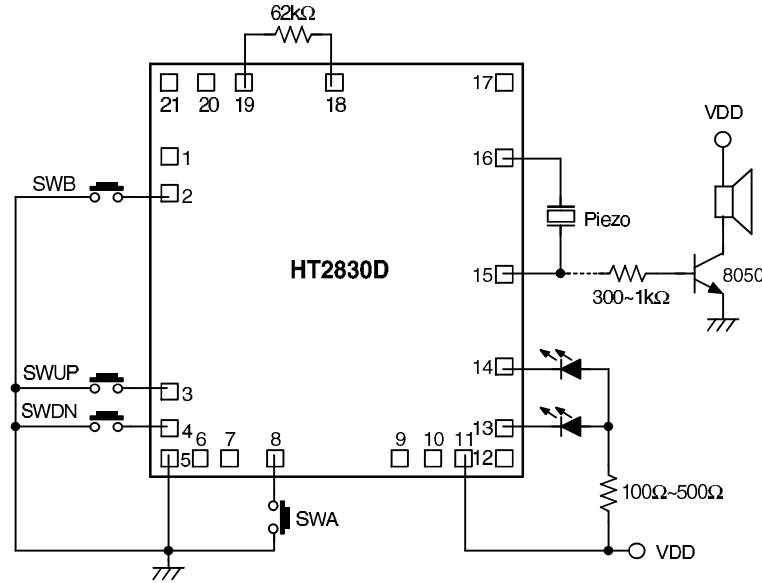

\* The IC substrate should be connected to VDD in PCB layout artwork.

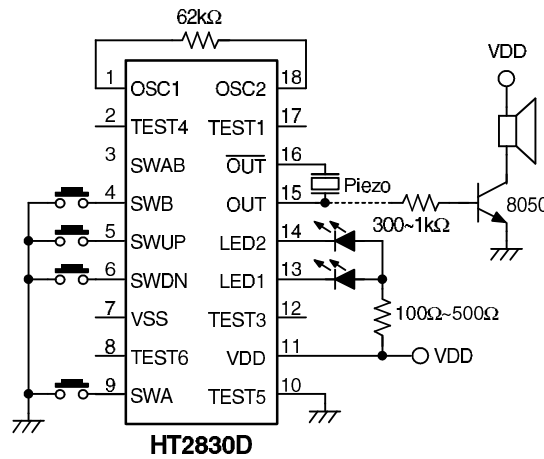

Main Tone: Motorcycle Sound  
 Fighting Sound 1: Machine Gun  
 Fighting Sound 2: Missile

Note: (1) The SWUP and SWDN keys are level hold trigger  
 (2) Power on auto play  
 (3) No auto-up and auto-down function