

TOSHIBA POWER TRANSISTOR MODULE SILICON NPN TRIPLE DIFFUSED TYPE (DARLINGTON POWER TRANSISTOR 4 IN 1)

MP4506

HIGH POWER SWITCHING APPLICATIONS.

HAMMER DRIVE, PULSE MOTOR DRIVE AND INDUCTIVE

LOAD SWITCHING.

- Package with Heat Sink Isolated to Lead (SIP 12 Pin)
- High Collector Power Dissipation (4 Devices Operation)
: $P_T = 5W$ ($T_a = 25^\circ C$)
- High Collector Current : I_C (DC) = 5A (Max.)
- High DC Current Gain : $h_{FE} = 1000$ (Min.) ($V_{CE} = 3V$, $I_C = 3A$)

MAXIMUM RATINGS ($T_a = 25^\circ C$)

CHARACTERISTIC		SYMBOL	RATING	UNIT
Collector-Base Voltage		V_{CBO}	100	V
Collector-Emitter Voltage		V_{CEO}	100	V
Emitter-Base Voltage		V_{EBO}	5	V
Collector Current	DC	I_C	5	A
	Pulse	I_{CP}	8	
Continuous Base Current		I_B	0.1	A
Collector Power Dissipation (1 Device Operation)		P_C	3.0	W
Collector Power Dissipation (4 Devices Operation)	$T_a = 25^\circ C$	P_T	5.0	W
	$T_c = 25^\circ C$		25	
Isolation Voltage		V_{Isol}	1000	V
Junction Temperature		T_j	150	$^\circ C$
Storage Temperature Range		T_{stg}	-55~150	$^\circ C$

INDUSTRIAL APPLICATIONS

Unit in mm

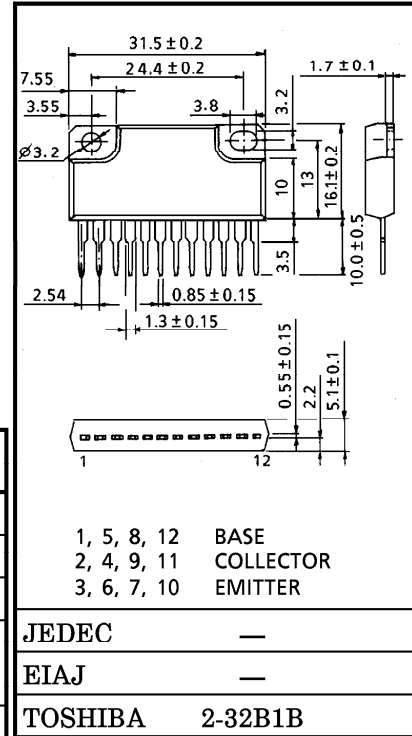

Weight : 6.0g

ARRAY CONFIGURATION

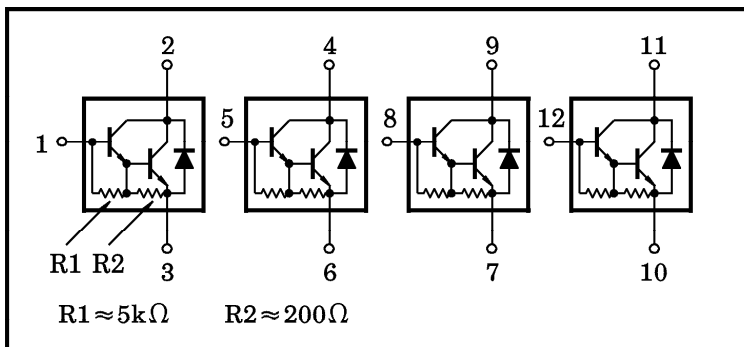

961001EAA2

● TOSHIBA is continually working to improve the quality and the reliability of its products. Nevertheless, semiconductor devices in general can malfunction or fail due to their inherent electrical sensitivity and vulnerability to physical stress. It is the responsibility of the buyer, when utilizing TOSHIBA products, to observe standards of safety, and to avoid situations in which a malfunction or failure of a TOSHIBA product could cause loss of human life, bodily injury or damage to property. In developing your designs, please ensure that TOSHIBA products are used within specified operating ranges as set forth in the most recent products specifications. Also, please keep in mind the precautions and conditions set forth in the TOSHIBA Semiconductor Reliability Handbook.

THERMAL CHARACTERISTICS

CHARACTERISTIC	SYMBOL	MAX.	UNIT
Thermal Resistance of Junction to Ambient (4 Devices Operation, Ta=25°C)	$\Sigma R_{th(j-a)}$	25	°C / W
Thermal Resistance of Junction to Case (4 Devices Operation, Tc=25°C)	$\Sigma R_{th(j-e)}$	5.0	°C / W
Maximum Lead Temperature for Soldering Purposes (3.2mm from Case for 10s)	T _L	260	°C

ELECTRICAL CHARACTERISTICS (Ta = 25°C)

CHARACTERISTIC	SYMBOL	TEST CONDITION	MIN.	TYP.	MAX.	UNIT			
Collector Cut-off Current	I _{CBO}	V _{CB} = 100V, I _E = 0	—	—	10	μA			
Collector Cut-off Current	I _{CEO}	V _{CE} = 100V, I _B = 0	—	—	10	μA			
Emitter Cut-off Current	I _{EBO}	V _{EB} = 5V, I _C = 0	0.3	—	2.0	mA			
Collector-Base Breakdown Voltage	V _{(BR) CBO}	I _C = 1mA, I _E = 0	100	—	—	V			
Collector-Emitter Breakdown Voltage	V _{(BR) CEO}	I _C = 30mA, I _B = 0	100	—	—	V			
DC Current Gain	h _{FE} (1)	V _{CE} = 3V, I _C = 0.5A	1000	—	—				
	h _{FE} (2)	V _{CE} = 3V, I _C = 3A	1000	—	—				
Saturation Voltage	Collector-Emitter	V _{CE (sat)}	I _C = 3A, I _B = 12mA	—	—	V			
	Base-Emitter	V _{BE (sat)}	I _C = 3A, I _B = 12mA	—	—		2.5		
Transition Frequency	f _T	V _{CE} = 3V, I _C = 0.5A	3	—	—	MHz			
Collector Output Capacitance	C _{ob}	V _{CB} = 10V, I _E = 0, f = 1MHz	—	40	—	pF			
Switching Time	Turn-on Time	t _{on}				—	0.5	—	μs
	Storage Time	t _{stg}				—	3.0	—	
	Fall Time	t _f				—	2.0	—	

961001EAA2'

● The information contained herein is presented only as a guide for the applications of our products. No responsibility is assumed by TOSHIBA CORPORATION for any infringements of intellectual property or other rights of the third parties which may result from its use. No license is granted by implication or otherwise under any intellectual property or other rights of TOSHIBA CORPORATION or others.
 ● The information contained herein is subject to change without notice.

EMITTER-COLLECTOR DIODE RATINGS AND CHARACTERISTICS (Ta = 25°C)

CHARACTERISTIC	SYMBOL	TEST CONDITION	MIN.	TYP.	MAX.	UNIT
Maximum Forward Current	I_{FM}	—	—	—	5	A
Surge Current	I_{FSM}	t = 1s, 1 shot	—	—	8	A
Forward Voltage	V_F	$I_F = 1A, I_B = 0$	—	1.2	1.8	V
Reverse Recovery Time	t_{rr}	$I_F = 3A, V_{BE} = -3V,$	—	1.0	—	μs
Reverse Recovery Charge	Q_{rr}	$dI_F / dt = -50A / \mu s$	—	5	—	μC

