

High Power 5 × 4 Antenna Switch MMIC with Integrated Control Logic for PDC Dual Phone

Description

The CXG1127ER is a high power antenna switch MMIC for PDC 800MHz and 1.5GHz dual phone. The CXG1127ER is suited to connect 2Tx/3Rx to one of 4 antennas. The CXG1127ER has on-chip logic circuit for operation with 5 CMOS inputs. The Sony's GaAs J-FET process is used for low insertion loss and low voltage operation.

24 pin VQFN (Plastic)

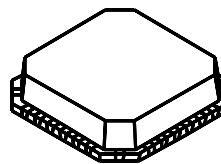

Features

- Low insertion loss: 0.45dB @900MHz, 0.55dB @1.5GHz
- High linearity: Harmonic < -65dBc
- CMOS compatible input control
- Small package: 24-pin VQFN (4.0mm × 4.0mm)

Applications

5 × 4 antenna switch for digital cellular such as PDC handsets

Structure

GaAs J-FET MMIC

Absolute Maximum Ratings (Ta = 25°C)

• Bias voltage	V _{DD}	7	V
• Control voltage	V _{DD}	5	V
• Operating temperature	T _{opr}	-35 to +85	°C
• Storage temperature	T _{stg}	-65 to +150	°C

GaAs MMICs are ESD sensitive devices. Special handling precautions are required.

Sony reserves the right to change products and specifications without prior notice. This information does not convey any license by any implication or otherwise under any patents or other right. Application circuits shown, if any, are typical examples illustrating the operation of the devices. Sony cannot assume responsibility for any problems arising out of the use of these circuits.

Block Diagram

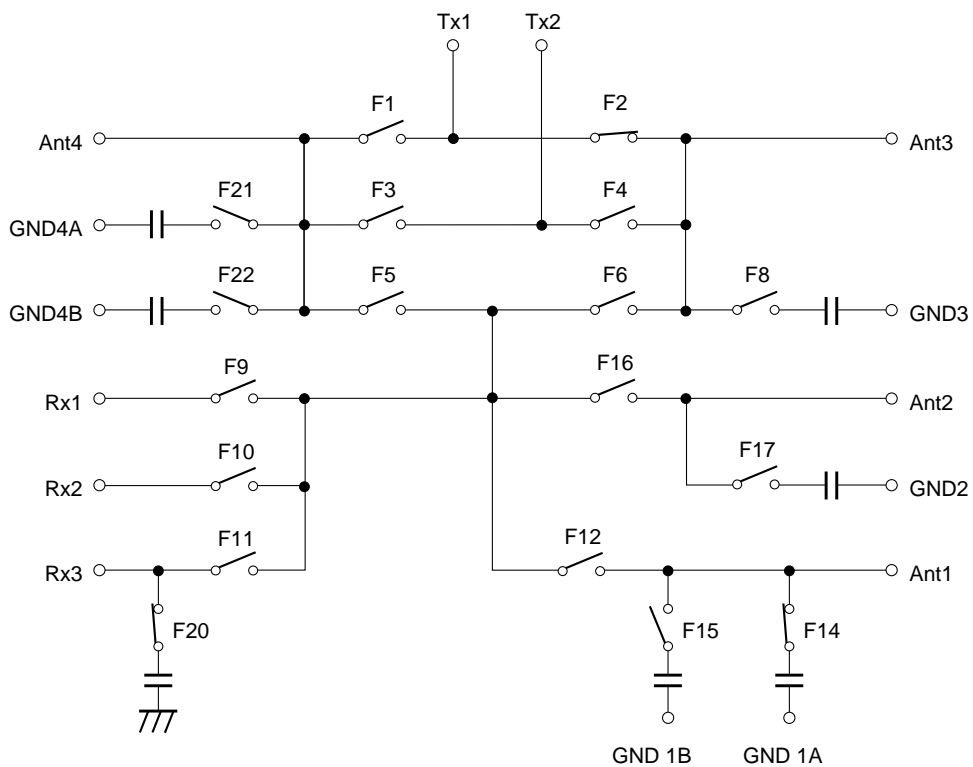

Pin Configuration/Recommended Circuit

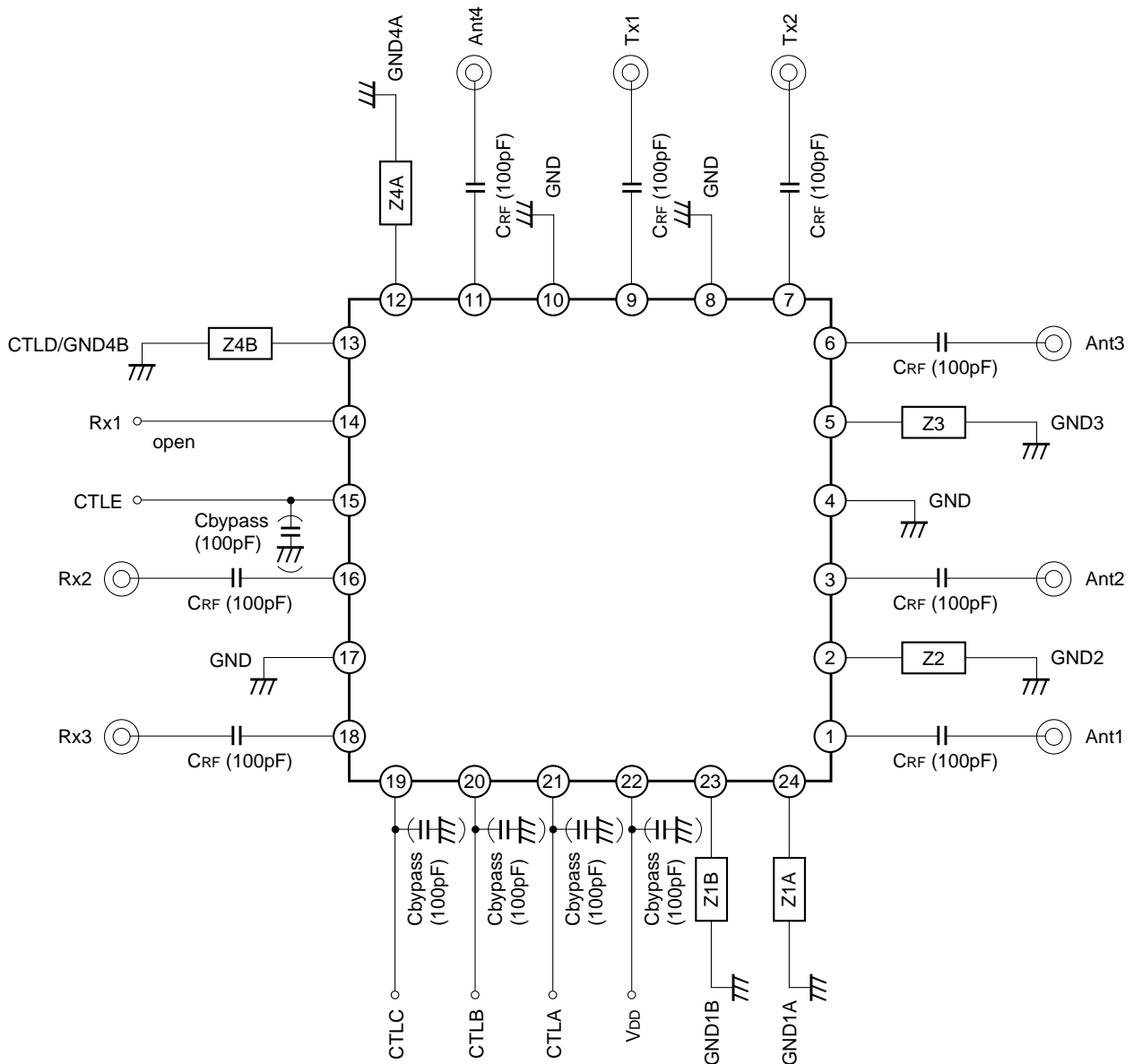

When using this IC, the following external components should be used:

CRF: This capacitor is used for RF de-coupling and must be used for all applications. 100pF is recommended.

Cbypass: This capacitor is used for DC line filtering. 100pF is recommended.

In the case that Rx1 is not used, the processing of the pin is as follows:

- Rx1 is recommended to be open.
- CTLD/GNG4B should be grounded as a DC.

Truth Table

A: Rx/Tx

B: main/diversity

C: External/antenna

D: 800MHz digital/800MHz analog

E: 800MHz/1.5GHz

State	On Pass	A	B	C	D	E	F1	F2	F3	F4	F5	F6	F8	F9	F10	F11	F12	F14	F15	F16	F17	F20	F21	F22
1	Tx1 – Ant3	H	—	L	—	L	L	H	H	L	L	L	L	L	L	L	L	H	L	L	H	H	H	L
2	Tx1 – Ant4	H	—	H	—	L	H	L	L	H	L	L	H	L	L	L	L	H	L	L	H	H	L	L
3	Tx2 – Ant3	H	—	L	—	H	H	L	L	H	L	L	L	L	L	L	L	L	H	L	H	H	L	H
4	Tx2 – Ant4	H	—	H	—	H	L	H	H	L	L	L	H	L	L	L	L	L	H	L	H	H	L	L
5	Rx1 – Ant3	L	L	L	H	L	H	L	H	L	L	H	L	H	L	L	L	H	L	L	H	H	H	L
6	Rx2 – Ant3	L	L	L	L	L	H	L	H	L	L	H	L	L	H	L	L	H	L	L	H	H	H	L
7	Rx3 – Ant3	L	L	L	—	H	H	L	H	L	L	H	L	L	L	H	L	L	H	L	H	L	L	H
8	Rx1 – Ant4	L	L	H	H	L	L	H	L	H	H	L	H	H	L	L	L	H	L	L	H	H	L	L
9	Rx2 – Ant4	L	L	H	L	L	L	H	L	H	H	L	H	L	H	L	L	H	L	L	H	H	L	L
10	Rx3 – Ant4	L	L	H	—	H	L	H	L	H	H	L	H	L	L	H	L	L	H	L	H	L	L	L
11	Rx1 – Ant2	L	H	L	H	L	L	L	L	L	L	L	H	H	L	L	L	H	L	H	L	H	H	L
12	Rx2 – Ant2	L	H	L	L	L	L	L	L	L	L	L	H	L	H	L	L	H	L	H	L	H	H	L
13	Rx3 – Ant2	L	H	L	—	H	L	L	L	L	L	L	H	L	L	H	L	L	H	H	L	L	L	H
14	Rx1 – Ant1	L	H	H	H	L	L	L	L	L	L	L	H	H	L	L	H	L	L	L	H	H	H	L
15	Rx2 – Ant1	L	H	H	L	L	L	L	L	L	L	L	H	L	H	L	H	L	L	L	H	H	H	L
16	Rx3 – Ant1	L	H	H	—	H	L	L	L	L	L	L	H	L	L	H	H	L	L	L	H	L	L	H

DC Bias Condition

(Ta = 25°C)

Item	Min.	Typ.	Max.	Unit
V _{DD}	2.4	3.0	3.3	V
V _{ctl} (H)	2.0	3.0	3.3	V
V _{ctl} (L)	0		0.4	V

Electrical Characteristics

(Ta = 25°C)

Item	Symbol	Port	Condition	Min.	Typ.	Max.	Unit
Insertion loss	IL	Tx1 – Ant3	*1	—	0.45	0.75	dB
		Tx1 – Ant4	*1	—	0.45	0.75	dB
		Tx2 – Ant3	*2	—	0.55	0.85	dB
		Tx2 – Ant4	*2	—	0.55	0.85	dB
		Rx2 – Ant3	*3	—	0.85	1.15	dB
		Rx2 – Ant4	*3	—	0.90	1.20	dB
		Rx2 – Ant2	*3	—	0.65	0.95	dB
		Rx2 – Ant1	*3	—	0.65	0.95	dB
		Rx3 – Ant3	*4	—	1.10	1.40	dB
		Rx3 – Ant4	*4	—	1.15	1.45	dB
		Rx3 – Ant2	*4	—	0.80	1.10	dB
		Rx3 – Ant1	*4	—	0.80	1.10	dB
Harmonics	2fo	Tx1 – Ant3	*5	—	-75	-60	dBc
		Tx1 – Ant4	*5	—	-75	-60	dBc
		Tx2 – Ant3	*6	—	-75	-60	dBc
		Tx2 – Ant4	*6	—	-75	-60	dBc
	3fo	Tx1 – Ant3	*5	—	-70	-60	dBc
		Tx1 – Ant4	*5	—	-70	-60	dBc
		Tx2 – Ant3	*6	—	-70	-60	dBc
		Tx2 – Ant4	*6	—	-70	-60	dBc
ACP	±50kHz	Tx1 – Ant3	*5	—	-67	-57	dBc
		Tx1 – Ant4	*5	—	-67	-57	dBc
		Tx2 – Ant3	*6	—	-67	-57	dBc
		Tx2 – Ant4	*6	—	-67	-57	dBc
	±100kHz	Tx1 – Ant3	*5	—	-73	-65	dBc
		Tx1 – Ant4	*5	—	-73	-65	dBc
		Tx2 – Ant3	*6	—	-73	-65	dBc
		Tx2 – Ant4	*6	—	-73	-65	dBc
P1dB	P1dB	Tx1 – Ant3	V _{DD} = 3V	33	34	—	dBm
		Tx1 – Ant4	V _{DD} = 3V	33	34	—	dBm
		Tx2 – Ant3	V _{DD} = 3V	33	34	—	dBm
		Tx2 – Ant4	V _{DD} = 3V	33	34	—	dBm
Switching speed	TSW			—	2	—	μs
Bias current	I _{DD}		V _{DD} = 3.0V	—	0.8	1.2	mA
Control current	I _{ctl}		V _{ctl} (H) = 3V	—	30	70	μA

-
- *1 Pin = 29.5dBm, 0/3V control, $V_{DD} = 3.0V$, 889MHz to 960MHz
 - *2 Pin = 29.5dBm, 0/3V control, $V_{DD} = 3.0V$, 1,439MHz to 1,443MHz
 - *3 Pin = 10dBm, 0/3V control, $V_{DD} = 3.0V$, 810MHz to 885MHz
 - *4 Pin = 10dBm, 0/3V control, $V_{DD} = 3.0V$, 1,487MHz to 1,491MHz
 - *5 $\pi/4$ -shifted DQPSK, Pin = 29.5dBm, 0/3V control, $V_{DD} = 3.0V$, 889MHz to 960MHz,
ACP ($\pm 50kHz$) < -70dBc, ACP ($\pm 100kHz$) < -75dBc, 2nd harmonics < -75dBc, 3rd harmonics < -75dBc
 - *6 $\pi/4$ -shifted DQPSK, Pin = 29.5dBm, 0/3V control, $V_{DD} = 3.0V$, 1,439MHz to 1,443MHz,
ACP ($\pm 50kHz$) < -70dBc, ACP ($\pm 100kHz$) < -75dBc, 2nd harmonics < -75dBc, 3rd harmonics < -75dBc
- * Rx1 is open for all conditions.

Package Outline Unit: mm

24PIN VQFN(PLASTIC)

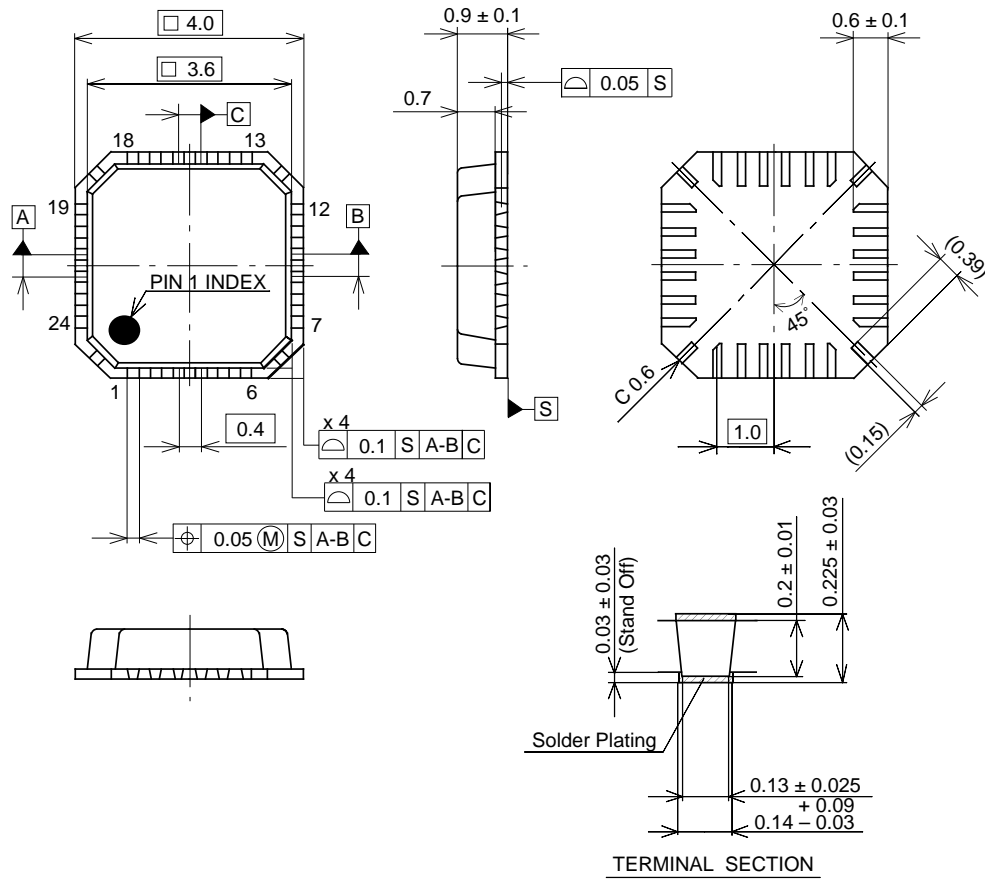

NOTE: 1) The dimensions of the terminal section apply to the ranges of 0.1mm and 0.25mm from the end of a terminal.

PACKAGE STRUCTURE

PACKAGE MATERIAL	EPOXY RESIN
LEAD TREATMENT	SOLDER PLATING
LEAD MATERIAL	COPPER ALLOY
PACKAGE MASS	0.04g

SONY CODE	VQFN-24P-03
EIAJ CODE	_____
JEDEC CODE	_____

LEAD SPECIFICATIONS

ITEM	SPEC.
LEAD MATERIAL	COPPER ALLOY
LEAD TREATMENT	Sn-Bi 2.5%
LEAD TREATMENT THICKNESS	5-18µm