



27-Bit, 2.5MHz-to-42MHz DC-Balanced LVDS Serializer

MAX9247

General Description

The MAX9247 digital video parallel-to-serial converter serializes 27 bits of parallel data into a serial-data stream. Eighteen bits of video data and 9 bits of control data are encoded and multiplexed onto the serial interface, reducing the serial-data rate. The data-enable input determines when the video or control data is serialized.

The MAX9247 pairs with the MAX9248/MAX9250 deserializers to form a complete digital video serial link. Interconnect can be controlled-impedance PC board traces or twisted-pair cable. Proprietary data encoding reduces EMI and provides DC balance. DC balance allows AC-coupling, providing isolation between the transmitting and receiving ends of the interface. The LVDS output is internally terminated with 100Ω. For operating frequencies less than 35MHz, the MAX9247 can also pair with the MAX9218 deserializer.

ESD tolerance is specified for ISO 10605 with ±10kV Contact Discharge and ±30kV Air-Gap Discharge.

The MAX9247 operates from a +3.3V core supply and features a separate input supply for interfacing to 1.8V to 3.3V logic levels. This device is available in 48-lead TQFP and TQFN packages and is specified from -40°C to +85°C.

Applications

- Navigation System Displays
- In-Vehicle Entertainment Systems
- Video Cameras
- LCDs

Features

- ◆ Preemphasis Improves Eye Diagram and Signal Integrity at the Output
- ◆ Proprietary Data Encoding for DC Balance and Reduced EMI
- ◆ Control Data Sent During Video Blanking
- ◆ Five Control Data Inputs are Single-Bit-Error Tolerant
- ◆ Programmable Phase-Shifted LVDS Signaling Reduces EMI
- ◆ Output Common-Mode Filter Reduces EMI
- ◆ Greater Than 10m STP Cable Drive
- ◆ Wide ±2% Reference Clock Tolerance
- ◆ ISO 10605 and IEC 61000-4-2 Level 4 ESD Protection
- ◆ Separate Input Supply Allows Interface to 1.8V to 3.3V Logic
- ◆ +3.3V Core Supply
- ◆ Space-Saving TQFP and TQFN Packages
- ◆ -40°C to +85°C Operating Temperature Range

Ordering Information

| PART | TEMP RANGE | PIN-PACKAGE | PKG CODE |
|--------------|----------------|--------------|----------|
| MAX9247ECM+ | -40°C to +85°C | 48 TQFP | C48-5 |
| MAX9247ETM+* | -40°C to +85°C | 48 TQFN-EP** | T4866-1 |

*Future part—contact factory for availability.

**EP = Exposed pad.

+Denotes lead-free package.

Pin Configurations

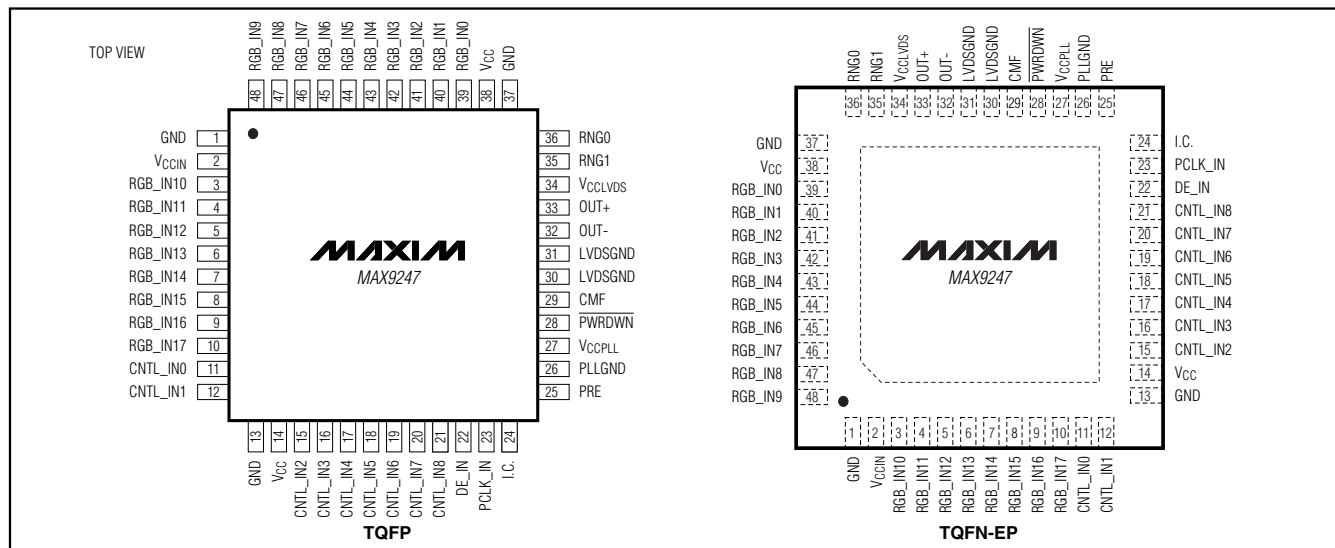

For pricing, delivery, and ordering information, please contact Maxim/Dallas Direct! at 1-888-629-4642, or visit Maxim's website at www.maxim-ic.com.

27-Bit, 2.5MHz-to-42MHz DC-Balanced LVDS Serializer

ABSOLUTE MAXIMUM RATINGS

| | |
|---------------------------------------------------------------------------------------|-------------------------------------|
| V _{CC_} to GND | -0.5V to +4.0V |
| Any Ground to Any Ground | -0.5V to +0.5V |
| OUT+, OUT- to LVDSGND | -0.5V to +4.0V |
| OUT+, OUT- Short Circuit to LVDSGND or V _{CC} LVDS | Continuous |
| OUT+, OUT- Short Through 0.125μF (or smaller), 25V Series Capacitor | -0.5V to +16V |
| RGB_IN[17:0], CNTL_IN[8:0], DE_IN, RNG0, RNG1, PRE, PCLK_IN, PWRDWN, CMF to GND | -0.5V to (V _{CCIN} + 0.5V) |
| Continuous Power Dissipation (T _A = +70°C) | |
| 48-Lead TQFP (derate 20.8mW/°C above +70°C) | 1667mW |
| 48-Lead TQFN (derate 37mW/°C above +70°C) | 2963mW |

ESD Protection

| | |
|-------------------------------------------------------------------|-----------------|
| Human Body Model (R _D = 1.5kΩ, C _S = 100pF) | |
| All Pins to GND | ±3kV |
| ISO 10605 (R _D = 2kΩ, C _S = 330pF) | |
| Contact Discharge (OUT+, OUT-) to GND | ±10kV |
| Air-Gap Discharge (OUT+, OUT-) to GND | ±30kV |
| IEC 61000-4-2 (R _D = 330Ω, C _S = 150pF) | |
| Contact Discharge (OUT+, OUT-) to GND | ±8kV |
| Air-Gap Discharge (OUT+, OUT-) to GND | ±15kV |
| Storage Temperature Range | -65°C to +150°C |
| Junction Temperature | +150°C |
| Lead Temperature (soldering, 10s) | +300°C |

Stresses beyond those listed under "Absolute Maximum Ratings" may cause permanent damage to the device. These are stress ratings only, and functional operation of the device at these or any other conditions beyond those indicated in the operational sections of the specifications is not implied. Exposure to absolute maximum rating conditions for extended periods may affect device reliability.

DC ELECTRICAL CHARACTERISTICS

(V_{CC_} = +3.0V to +3.6V, R_L = 100Ω ±1%, PWRDWN = high, PRE = low, T_A = -40°C to +85°C, unless otherwise noted. Typical values are at V_{CC_} = +3.3V, T_A = +25°C.) (Notes 1, 2)

| PARAMETER | SYMBOL | CONDITIONS | MIN | TYP | MAX | UNITS |
|--------------------------------------------------------------------------------------------|------------------|------------------------------------------------------------|------------------------------------------------------|-------------------------|-------|-------|
| SINGLE-ENDED INPUTS (RGB_IN[17:0], CNTL_IN[8:0], DE_IN, PCLK_IN, PWRDWN, RNG_, PRE) | | | | | | |
| High-Level Input Voltage | V _{IH} | V _{CCIN} = 1.71V to < 3V (Note 3) | 0.65 x V _{CCIN} | V _{CCIN} + 0.3 | | V |
| | | V _{CCIN} = 3.0V to 3.6V | 2 | 0.3 + V _{CCIN} | | |
| Low-Level Input Voltage | V _{IL} | V _{CCIN} = 1.71V to < 3V (Note 3) | -0.3 | 0.3 x V _{CCIN} | | V |
| | | V _{CCIN} = 3.0V to 3.6V | -0.3 | +0.8 | | |
| Input Current | I _{IN} | V _{CCIN} = 1.71V to 3.6V, PWRDWN = high or low | V _{IN} = -0.3V to 0 | -100 | +20 | μA |
| | | | V _{IN} = 0 to (V _{CCIN} + 0.3V) | -20 | +20 | |
| Input Clamp Voltage | V _{CL} | I _{CL} = -18mA | | | -1.5 | V |
| LVDS OUTPUTS (OUT+, OUT-) | | | | | | |
| Differential Output Voltage | V _{OD} | Figure 1 | 250 | 335 | 450 | mV |
| Change in V _{OD} Between Complementary Output States | ΔV _{OD} | Figure 1 | | | 20 | mV |
| Common-Mode Voltage | V _{OS} | Figure 1 | 1.125 | 1.29 | 1.475 | V |
| Change in V _{OS} Between Complementary Output States | ΔV _{OS} | Figure 1 | | | 20 | mV |
| Output Short-Circuit Current | I _{OS} | V _{OUT+} or V _{OUT-} = 0 or 3.6V | -15 | ±8 | +15 | mA |
| Magnitude of Differential Output Short-Circuit Current | I _{OSD} | V _{OD} = 0 | | 5.5 | 15 | mA |
| Output High-Impedance Current | I _{OZ} | PWRDWN = low or V _{CC_} = 0 | OUT+ = 0, OUT- = 3.6V | -1 | +1 | μA |
| | | | OUT+ = 3.6V, OUT- = 0 | | | |

27-Bit, 2.5MHz-to-42MHz DC-Balanced LVDS Serializer

MAX9247

DC ELECTRICAL CHARACTERISTICS (continued)

($V_{CC_} = +3.0V$ to $+3.6V$, $R_L = 100\Omega \pm 1\%$, $\overline{PWRDWN} = \text{high}$, $PRE = \text{low}$, $T_A = -40^\circ\text{C}$ to $+85^\circ\text{C}$, unless otherwise noted. Typical values are at $V_{CC_} = +3.3V$, $T_A = +25^\circ\text{C}$.) (Notes 1, 2)

| PARAMETER | SYMBOL | CONDITIONS | | MIN | TYP | MAX | UNITS |
|--------------------------------|-----------|------------------------------------------------------------------------------------------|--------|---------|-----|-----|---------------|
| Differential Output Resistance | R_O | | | 78 | 110 | 147 | Ω |
| Worst-Case Supply Current | I_{CCW} | $R_L = 100\Omega \pm 1\%$, $C_L = 5\text{pF}$, continuous 10 transition words | 2.5MHz | PRE = 0 | 15 | 25 | mA |
| | | | | PRE = 1 | | 27 | |
| | | | 5MHz | PRE = 0 | 18 | 25 | |
| | | | | PRE = 1 | | 27 | |
| | | | 10MHz | PRE = 0 | 23 | 28 | |
| | | | | PRE = 1 | | 30 | |
| | | | 20MHz | PRE = 0 | 33 | 39 | |
| | | | | PRE = 1 | | 42 | |
| | | | 35MHz | PRE = 0 | 50 | 65 | |
| | | | | PRE = 1 | | 69 | |
| | | | 42MHz | PRE = 0 | 60 | 70 | |
| | | | | PRE = 1 | | 75 | |
| Power-Down Supply Current | I_{CCZ} | (Note 4) | | | | 50 | μA |

AC ELECTRICAL CHARACTERISTICS

($V_{CC_} = +3.0V$ to $+3.6V$, $R_L = 100\Omega \pm 1\%$, $C_L = 5\text{pF}$, $\overline{PWRDWN} = \text{high}$, $PRE = \text{low}$, $T_A = -40^\circ\text{C}$ to $+85^\circ\text{C}$, unless otherwise noted. Typical values are at $V_{CC_} = +3.3V$, $T_A = +25^\circ\text{C}$.) (Note 3)

| PARAMETER | SYMBOL | CONDITIONS | | MIN | TYP | MAX | UNITS |
|--------------------------------------------------------------|------------------|------------------------------------------------------|------------|------|-----|-------|-------|
| PCLK_IN TIMING REQUIREMENTS | | | | | | | |
| Clock Period | t_T | Figure 2 | | 23.8 | | 400.0 | ns |
| Clock Frequency | f_{CLK} | | | 2.5 | | 42.0 | MHz |
| Clock Frequency Difference from Deserializer Reference Clock | Δf_{CLK} | | | -2 | | +2 | % |
| Clock Duty Cycle | DC | t_{HIGH}/t_T or t_{LOW}/t_T , Figure 2 | | 35 | 50 | 65 | % |
| Clock Transition Time | t_R, t_F | Figure 2 | | | | 2.5 | ns |
| SWITCHING CHARACTERISTICS | | | | | | | |
| Output Rise Time | t_{RISE} | 20% to 80%, $V_{OD} \geq 250\text{mV}$, Figure 3 | PRE = low | 280 | 370 | ps | |
| | | | PRE = high | 240 | 320 | | |
| Output Fall Time | t_{FALL} | 80% to 20%, $V_{OD} \geq 250\text{mV}$, Figure 3 | PRE = low | 280 | 370 | ps | |
| | | | PRE = high | 240 | 320 | | |
| Input Setup Time | t_{SET} | Figure 4 | | 3 | | | ns |
| Input Hold Time | t_{HOLD} | Figure 4 | | 3 | | | ns |

27-Bit, 2.5MHz-to-42MHz DC-Balanced LVDS Serializer

AC ELECTRICAL CHARACTERISTICS (continued)

($V_{CC_}$ = +3.0V to +3.6V, R_L = 100 Ω \pm 1%, C_L = 5pF, \overline{PWRDWN} = high, PRE = low, T_A = -40°C to +85°C, unless otherwise noted. Typical values are at $V_{CC_}$ = +3.3V, T_A = +25°C.) (Note 3)

| PARAMETER | SYMBOL | CONDITIONS | MIN | TYP | MAX | UNITS |
|------------------------------------|---------------|--------------------------------------------------------|-----------------------|-----|-----------------------|---------|
| Serializer Delay | t_{SD} | Figure 5 | 3.10 x $t_T + 2.0$ | | 3.10 x $t_T + 8.0$ | ns |
| PLL Lock Time | t_{LOCK} | Figure 6 | | | 17,100 x t_T | ns |
| Power-Down Delay | t_{PD} | Figure 7 | | | 1 | μ s |
| Peak-to-Peak Output Jitter | t_{JIT} | Measured with PRBS input pattern at 840Mbps data rate | | | 150 | ps |
| Peak-to-Peak Output Offset Voltage | $V_{OS(P-P)}$ | 840Mbps data rate, CMF open, Figure 8 | | 22 | 70 | mV |
| | | 840Mbps data rate, CMF 0.1 μ F to ground, Figure 8 | | 12 | 50 | |

Note 1: Current into a pin is defined as positive. Current out of a pin is defined as negative. All voltages are referenced to ground, except V_{OD} , ΔV_{OD} , and ΔV_{OS} .

Note 2: Maximum and minimum limits over temperature are guaranteed by design and characterization. Devices are production tested at T_A = +25°C.

Note 3: Parameters are guaranteed by design and characterization and are not production tested. Limits are set at ± 6 sigma.

Note 4: All LVTTTL/LVCMOS inputs, except \overline{PWRDWN} at $\leq 0.3V$ or $\geq V_{CCIN} - 0.3V$. \overline{PWRDWN} is $\leq 0.3V$.

27-Bit, 2.5MHz-to-42MHz DC-Balanced LVDS Serializer

MAX9247

Typical Operating Characteristics

($V_{CC_} = +3.3V$, $R_L = 100\Omega$, $T_A = +25^\circ C$, unless otherwise noted.)

**WORST-CASE PATTERN
SUPPLY CURRENT vs. FREQUENCY**

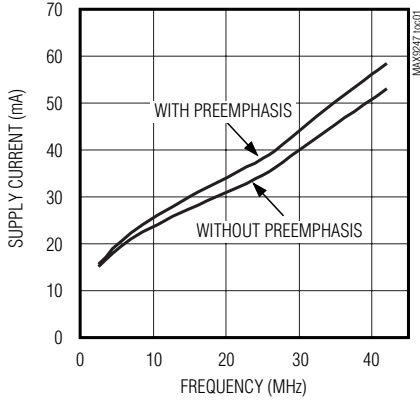

EYE DIAGRAM WITHOUT PREAMPHASIS

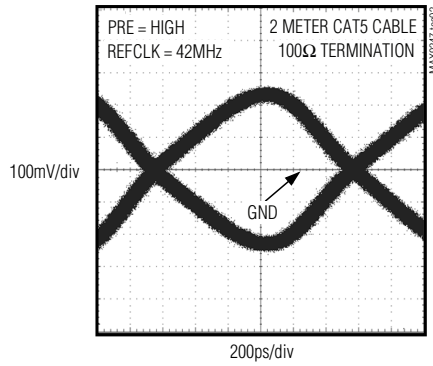

EYE DIAGRAM WITH PREAMPHASIS

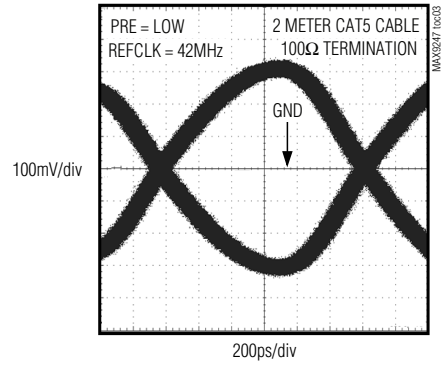

BIT-ERROR RATE vs. CABLE LENGTH

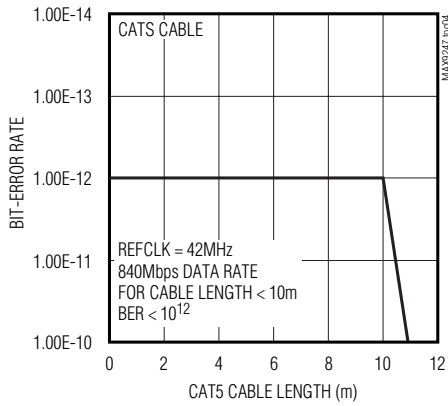

**CABLE LENGTH
vs. FREQUENCY BIT-ERROR RATE < 10E-9**

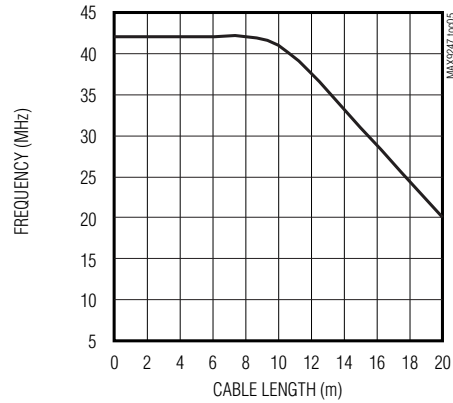

27-Bit, 2.5MHz-to-42MHz DC-Balanced LVDS Serializer

Pin Description

| PIN | NAME | FUNCTION |
|----------------|-------------------------------------------------|------------------------------------------------------------------------------------------------------------------------------------------------------------------------------------------------------------|
| 1, 13, 37 | GND | Input Buffer Supply and Digital Supply Ground |
| 2 | V _{CCIN} | Input Buffer Supply Voltage. Bypass to GND with 0.1μF and 0.001μF capacitors in parallel as close to the device as possible, with the smallest value capacitor closest to the supply pin. |
| 3–10, 39–48 | RGB_IN10– RGB_IN17, RGB_IN0– RGB_IN9 | LVTTTL/LVCMOS Red, Green, and Blue Digital Video Data Inputs. Eighteen data bits are loaded into the input latch on the rising edge of PCLK_IN when DE_IN is high. Internally pulled down to GND. |
| 11, 12, 15–21 | CNTL_IN0, CNTL_IN1, CNTL_IN2– CNTL_IN8 | LVTTTL/LVCMOS Control Data Inputs. Control data are latched on the rising edge of PCLK_IN when DE_IN is low. Internally pulled down to GND. |
| 14, 38 | V _{CC} | Digital Supply Voltage. Bypass to GND with 0.1μF and 0.001μF capacitors in parallel as close to the device as possible, with the smallest value capacitor closest to the supply pin. |
| 22 | DE_IN | LVTTTL/LVCMOS Data-Enable Input. Logic-high selects RGB_IN[17:0] to be latched. Logic-low selects CNTL_IN[8:0] to be latched. DE_IN must be switching for proper operation. Internally pulled down to GND. |
| 23 | PCLK_IN | LVTTTL/LVCMOS Parallel Clock Input. Latches data and control inputs and provides the PLL reference clock. Internally pulled down to GND. |
| 24 | I.C. | Internally Connected. Leave floating for normal operation. |
| 25 | PRE | Preemphasis Enable Input. Drive PRE high to enable preemphasis. |
| 26 | PLL_GND | PLL Supply Ground |
| 27 | V _{CCPLL} | PLL Supply Voltage. Bypass to PLL_GND with 0.1μF and 0.001μF capacitors in parallel as close to the device as possible, with the smallest value capacitor closest to the supply pin. |
| 28 | PWRDWN | LVTTTL/LVCMOS Power-Down Input. Internally pulled down to GND. |
| 29 | CMF | Common-Mode Filter. Optionally connect a capacitor between CMF and ground to filter common-mode switching noise. |
| 30, 31 | LVDS_GND | LVDS Supply Ground |
| 32 | OUT- | Inverting LVDS Serial-Data Output |
| 33 | OUT+ | Noninverting LVDS Serial-Data Output |
| 34 | V _{CCLVDS} | LVDS Supply Voltage. Bypass to LVDS_GND with 0.1μF and 0.001μF capacitors in parallel as close to the device as possible, with the smallest value capacitor closest to the supply pin. |
| 35 | RNG1 | LVTTTL/LVCMOS Frequency Range Select Input. Set to the frequency range that includes the PCLK_IN frequency as shown in Table 3. Internally pulled down to GND. |
| 36 | RNG0 | LVTTTL/LVCMOS Frequency Range Select Input. Set to the frequency range that includes the PCLK_IN frequency as shown in Table 3. Internally pulled down to GND. |
| EP | GND | Exposed Pad (TQFN Package Only). Connect to GND. |

27-Bit, 2.5MHz-to-42MHz DC-Balanced LVDS Serializer

Functional Diagram

MAX9247

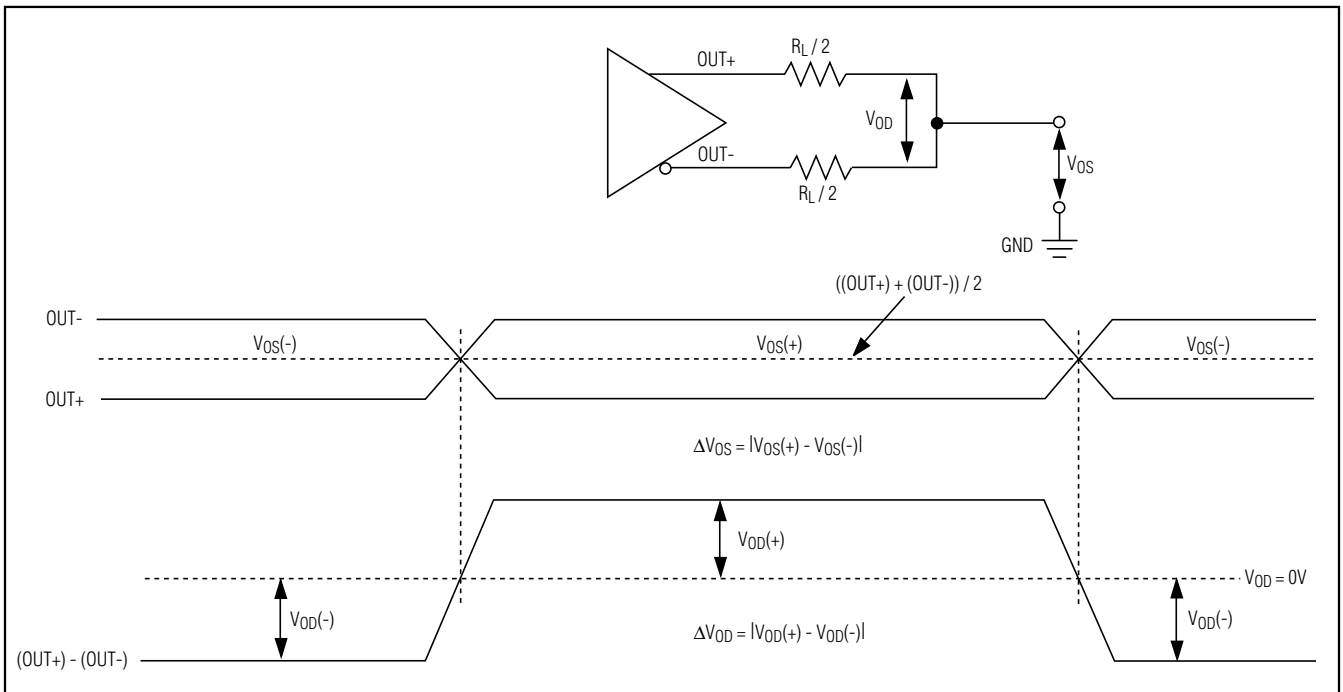
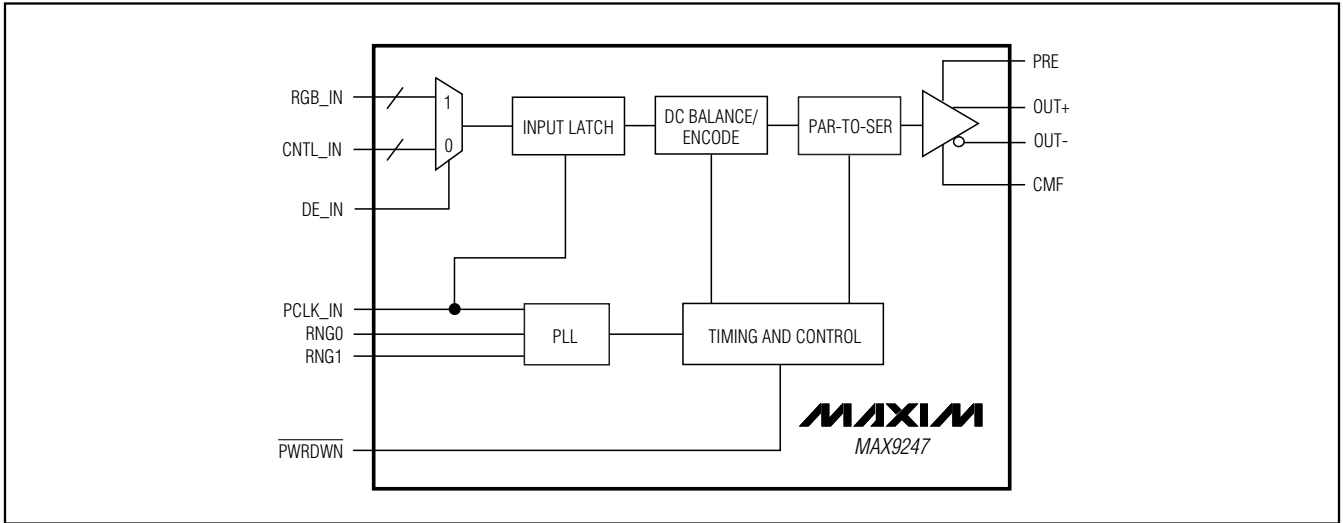

Figure 1. LVDS DC Output Load and Parameters

27-Bit, 2.5MHz-to-42MHz DC-Balanced LVDS Serializer

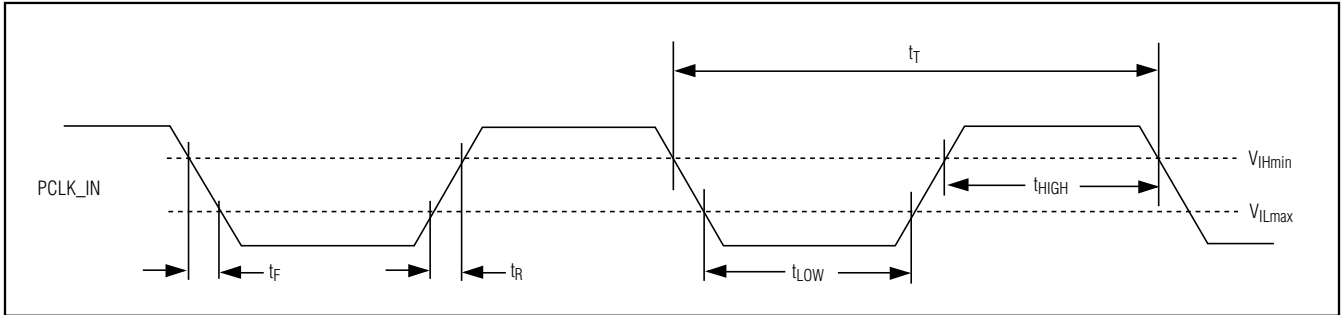

Figure 2. Parallel Clock Requirements

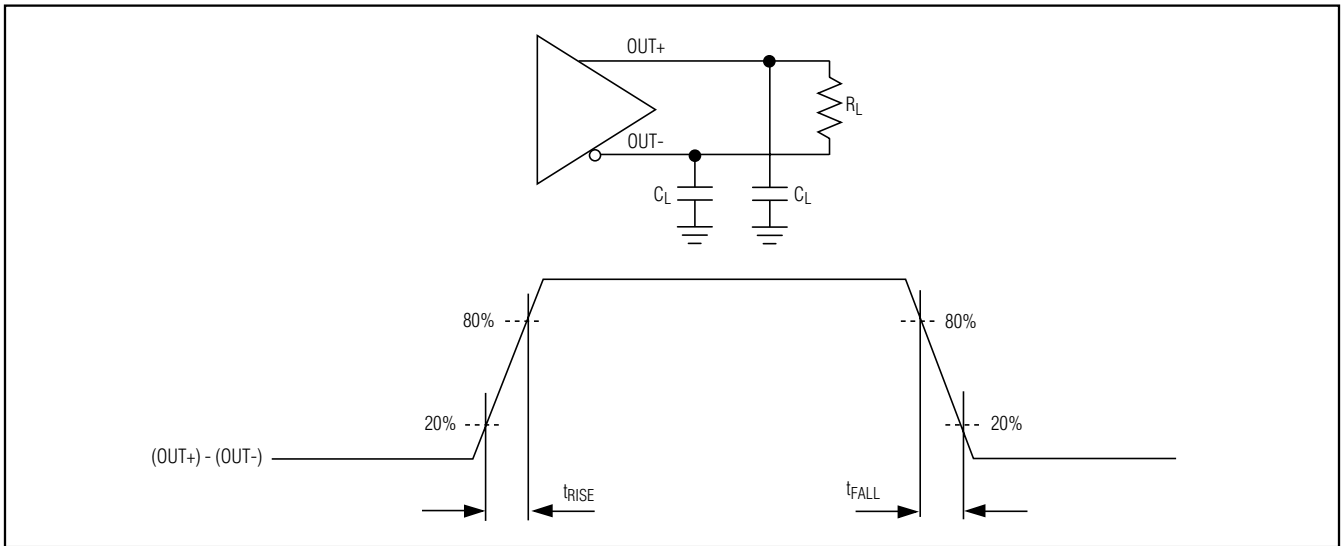

Figure 3. Output Rise and Fall Times

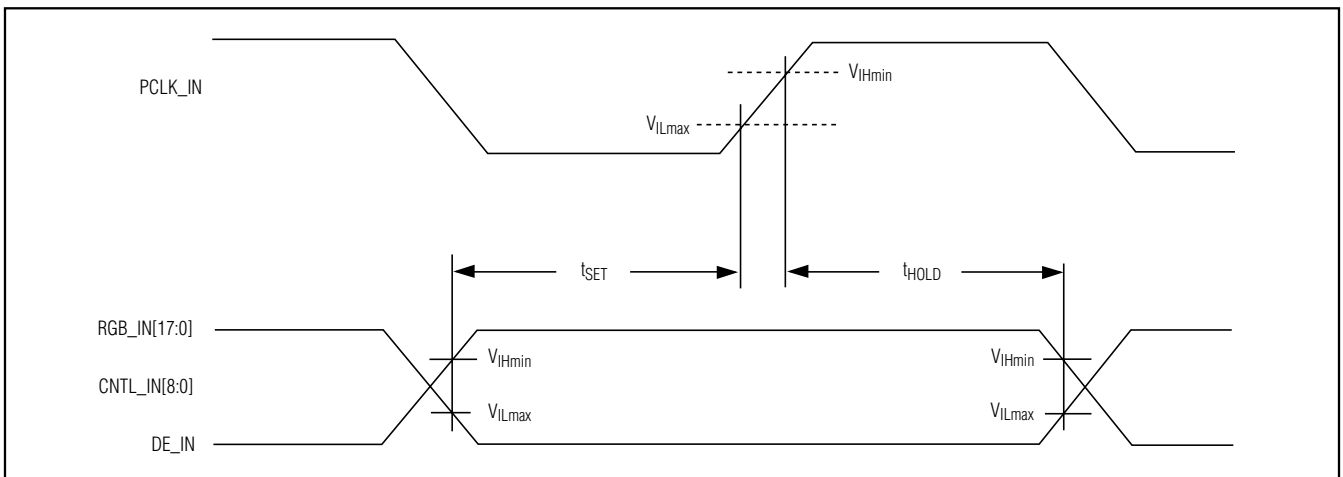

Figure 4. Synchronous Input Timing

27-Bit, 2.5MHz-to-42MHz DC-Balanced LVDS Serializer

MAX9247

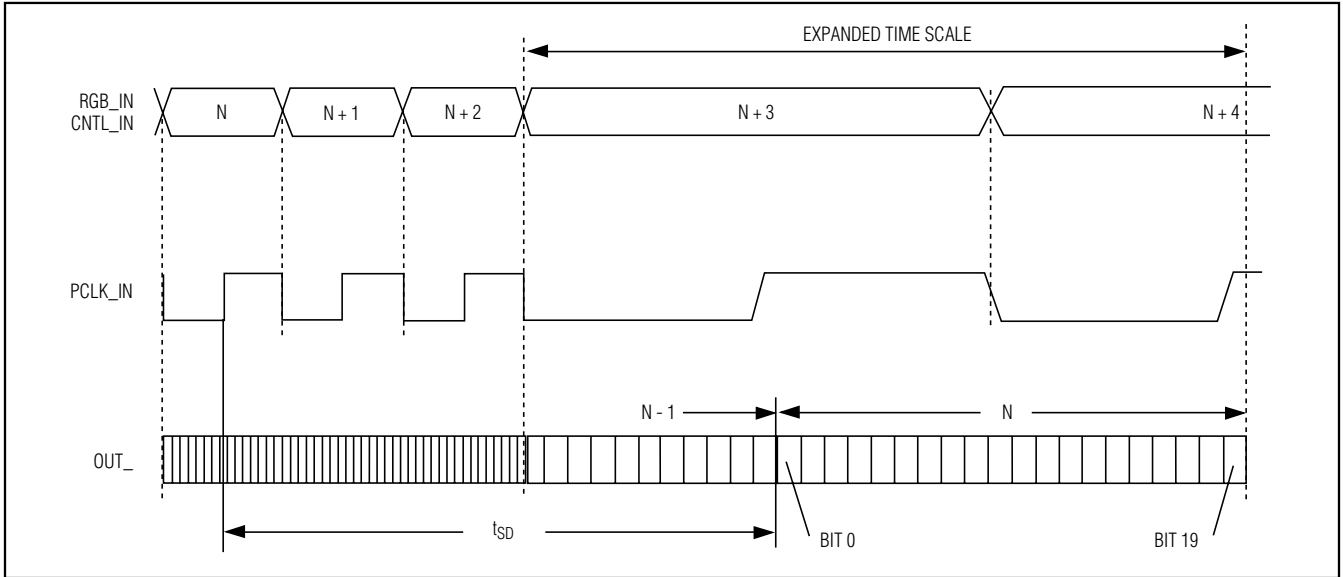

Figure 5. Serializer Delay

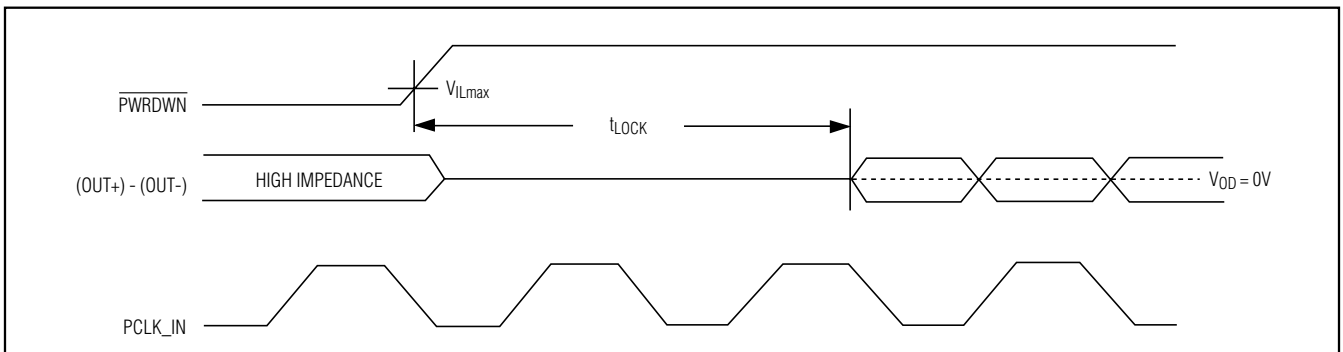

Figure 6. PLL Lock Time

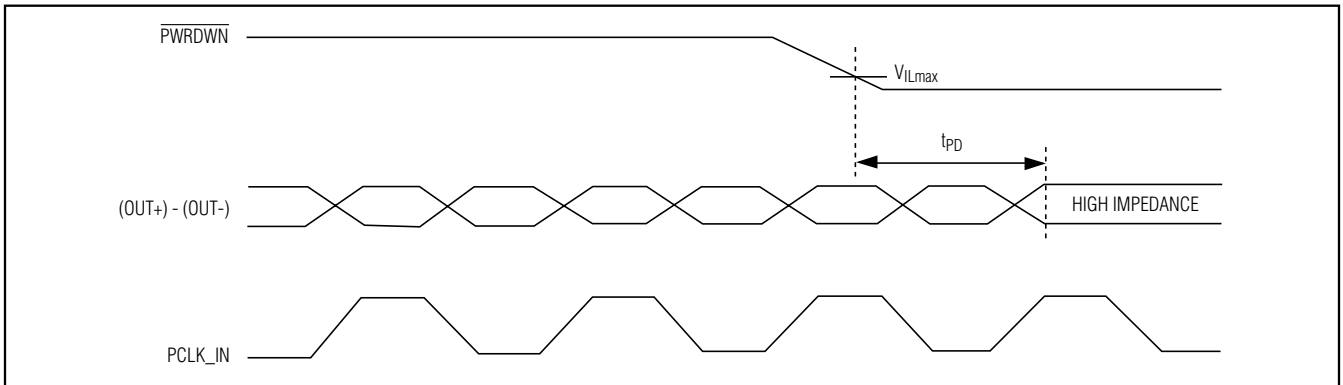

Figure 7. Power-Down Delay

27-Bit, 2.5MHz-to-42MHz DC-Balanced LVDS Serializer

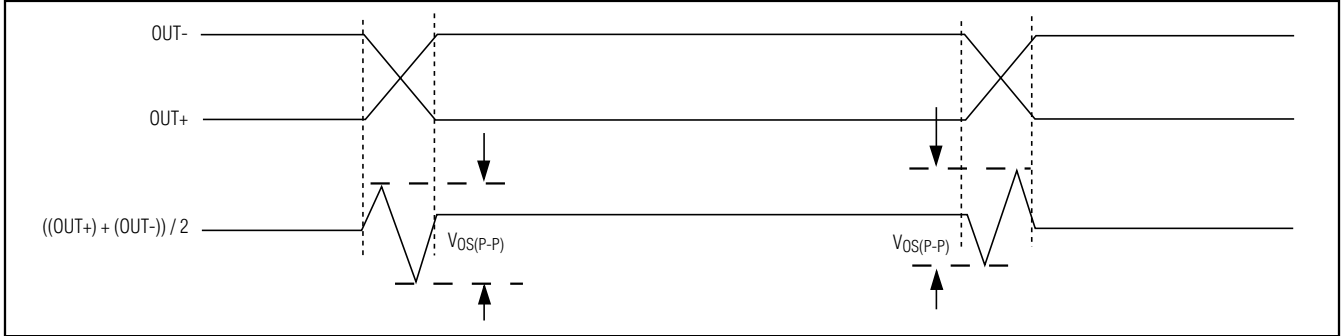

Figure 8. Peak-to-Peak Output Offset Voltage

Detailed Description

The MAX9247 DC-balanced serializer operates at a 2.5MHz-to-42MHz parallel clock frequency, serializing 18 bits of parallel video data RGB_IN[17:0] when the data-enable input DE_IN is high, or 9 bits of parallel control data CNTL_IN[8:0] when DE_IN is low. The RGB video input data are encoded using 2 overhead bits, EN0 and EN1, resulting in a serial word length of 20 bits (see Table 1). Control inputs are mapped to 19 bits and encoded with 1 overhead bit, EN0, also resulting in a 20-bit serial word. Encoding reduces EMI and

maintains DC balance across the serial cable. Two transition words, which contain a unique bit sequence, are inserted at the transition boundaries of video-to-control and control-to-video phases.

Control data inputs C0 to C4 are mapped to 3 bits each in the serial control word (see Table 2). At the deserializer, 2 or 3 bits at the same state determine the state of the recovered bit, providing single-bit-error tolerance for C0 to C4. Control data that may be visible if an error occurs, such as VSYNC and HSYNC, can be connected to these inputs. Control data inputs C5 to C8 are mapped to 1 bit each.

Table 1. Serial Video Phase Word Format

| | | | | | | | | | | | | | | | | | | | |
|-----|-----|----|----|----|----|----|----|----|----|----|----|-----|-----|-----|-----|-----|-----|-----|-----|
| 0 | 1 | 2 | 3 | 4 | 5 | 6 | 7 | 8 | 9 | 10 | 11 | 12 | 13 | 14 | 15 | 16 | 17 | 18 | 19 |
| EN0 | EN1 | S0 | S1 | S2 | S3 | S4 | S5 | S6 | S7 | S8 | S9 | S10 | S11 | S12 | S13 | S14 | S15 | S16 | S17 |

Bit 0 is the LSB and is serialized first. EN[1:0] are encoding bits. S[17:0] are encoded symbols.

Table 2. Serial Control Phase Word Format

| | | | | | | | | | | | | | | | | | | | |
|-----|----|----|----|----|----|----|----|----|----|----|----|----|----|----|----|----|----|----|----|
| 0 | 1 | 2 | 3 | 4 | 5 | 6 | 7 | 8 | 9 | 10 | 11 | 12 | 13 | 14 | 15 | 16 | 17 | 18 | 19 |
| EN0 | C0 | C0 | C0 | C1 | C1 | C1 | C2 | C2 | C2 | C3 | C3 | C3 | C4 | C4 | C4 | C5 | C6 | C7 | C8 |

Bit 0 is the LSB and is serialized first. C[8:0] are the control inputs.

27-Bit, 2.5MHz-to-42MHz DC-Balanced LVDS Serializer

MAX9247

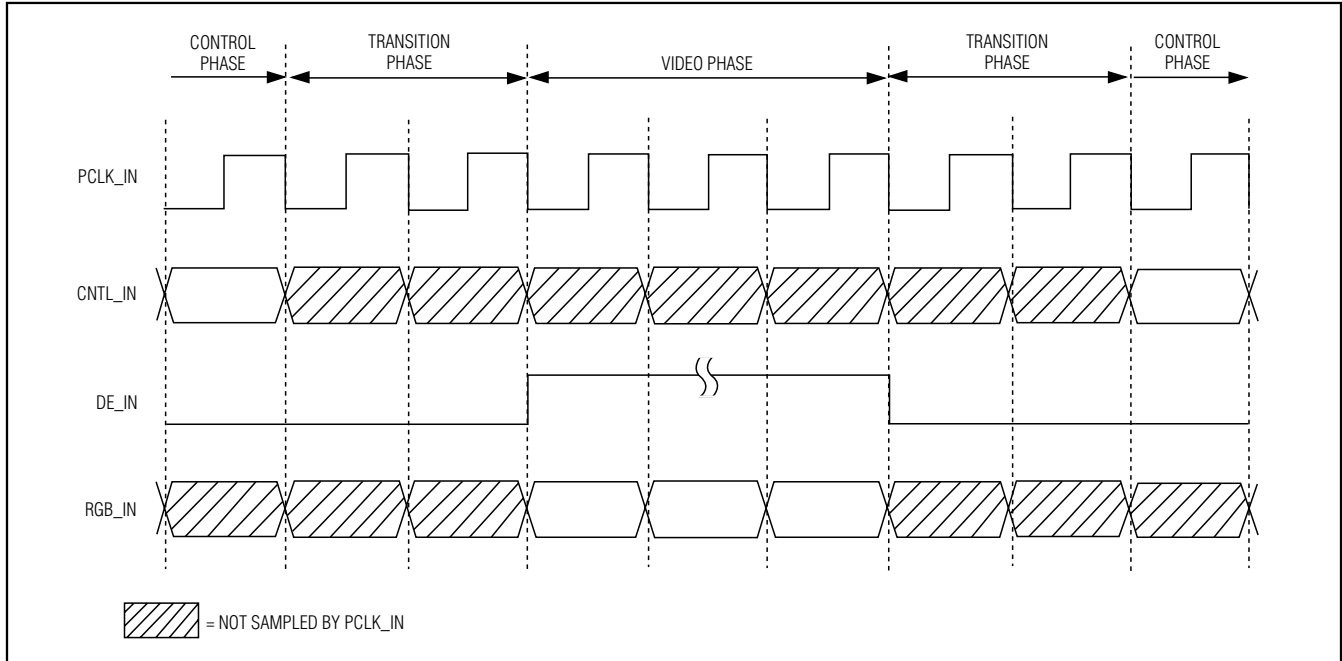

Figure 9. Transition Timing

Transition Timing

The transition words require interconnect bandwidth and displace control data. Therefore, control data is not sampled (see Figure 9):

- Two clock cycles before DE_IN goes high
- During the video phase
- Two clock cycles after DE_IN goes low

The last sampled control data are latched at the deserializer control data outputs during the transition and video phases. Video data are latched at the deserializer RGB data outputs during the transition and control phases.

Applications Information

AC-Coupling Benefits

AC-coupling increases the common-mode voltage to the voltage rating of the capacitor. Two capacitors are sufficient for isolation, but four capacitors—two at the serializer output and two at the deserializer input—provide protection if either end of the cable is shorted to a high voltage. AC-coupling blocks low-frequency ground shifts and common-mode noise. The MAX9247 serializer can also be DC-coupled to the MAX9248/MAX9250 deserializers.

Figures 10 and 12 show an AC-coupled serializer and deserializer with two capacitors per link. Figures 11 and

13 show the AC-coupled serializer and deserializer with four capacitors per link.

Selection of AC-Coupling Capacitors

See Figure 14 for calculating the capacitor values for AC-coupling depending on the parallel clock frequency. The plot shows capacitor values for two- and four-capacitor-per-link systems. For applications using less than 18MHz clock frequency, use 0.125µF capacitors.

Frequency-Range Setting RNG[1:0]

The RNG[1:0] inputs select the operating frequency range of the MAX9247 serializer. An external clock within this range is required for operation. Table 3 shows the selectable frequency ranges and corresponding data rates for the MAX9247.

Table 3. Parallel Clock Frequency Range Select

| RNG1 | RNG0 | PARALLEL CLOCK (MHz) | SERIAL-DATA RATE (Mbps) |
|------|------|----------------------|-------------------------|
| 0 | 0 | 2.5 to 5 | 50 to 100 |
| 0 | 1 | 5 to 10 | 100 to 200 |
| 1 | 0 | 10 to 20 | 200 to 400 |
| 1 | 1 | 20 to 42 | 400 to 840 |

27-Bit, 2.5MHz-to-42MHz DC-Balanced LVDS Serializer

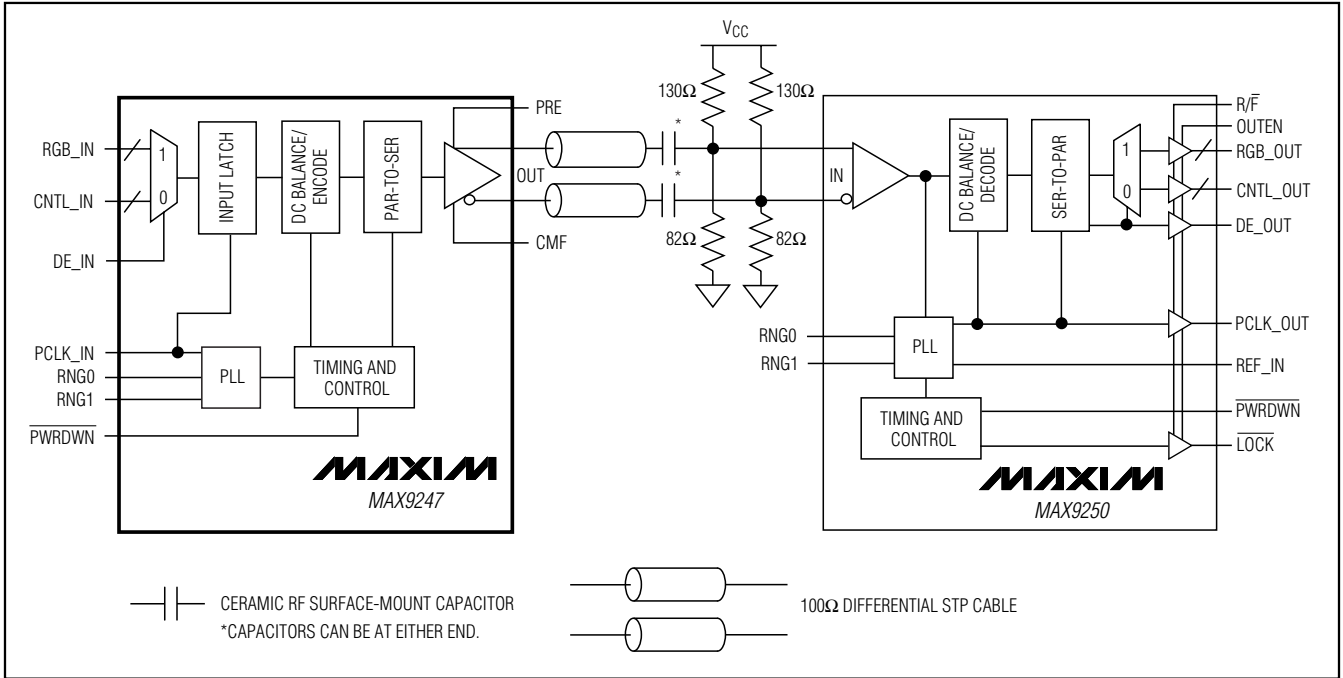

Figure 10. AC-Coupled MAX9247 Serializer and MAX9250 Deserializer with Two Capacitors per Link

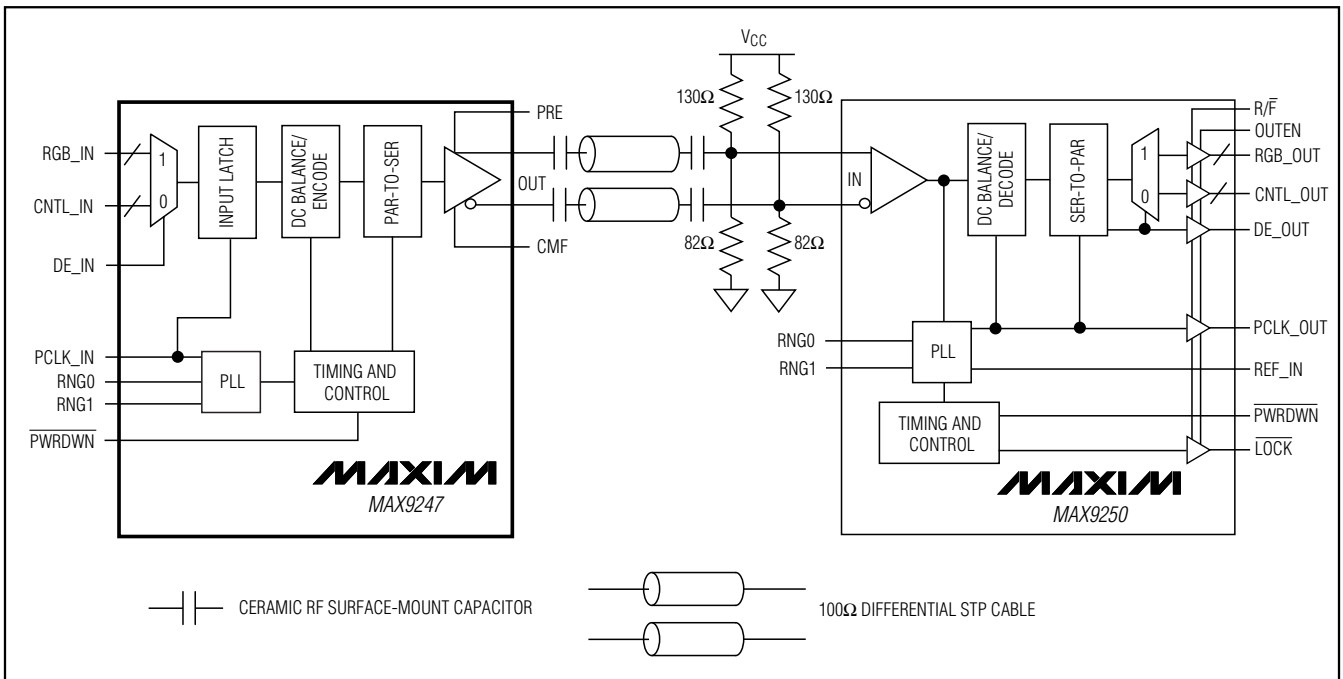

Figure 11. AC-Coupled MAX9247 Serializer and MAX9250 Deserializer with Four Capacitors per Link

27-Bit, 2.5MHz-to-42MHz DC-Balanced LVDS Serializer

MAX9247

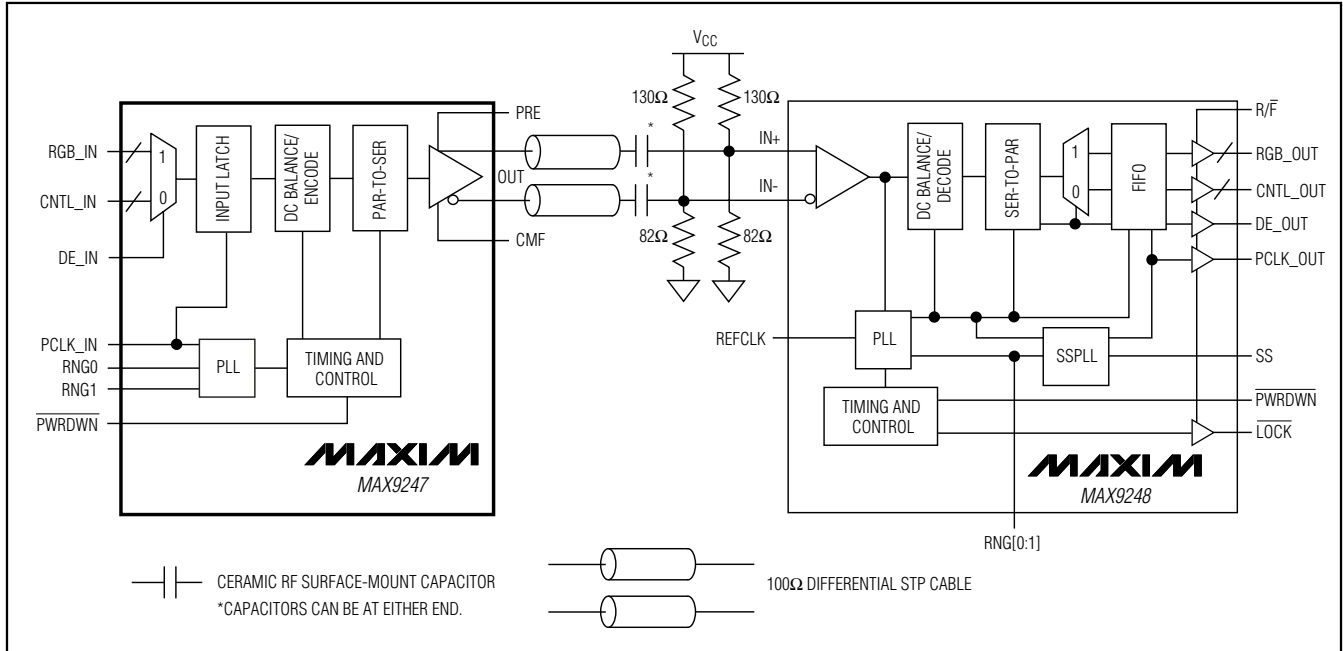

Figure 12. AC-Coupled MAX9247 Serializer and MAX9248 Deserializer with Two Capacitors per Link

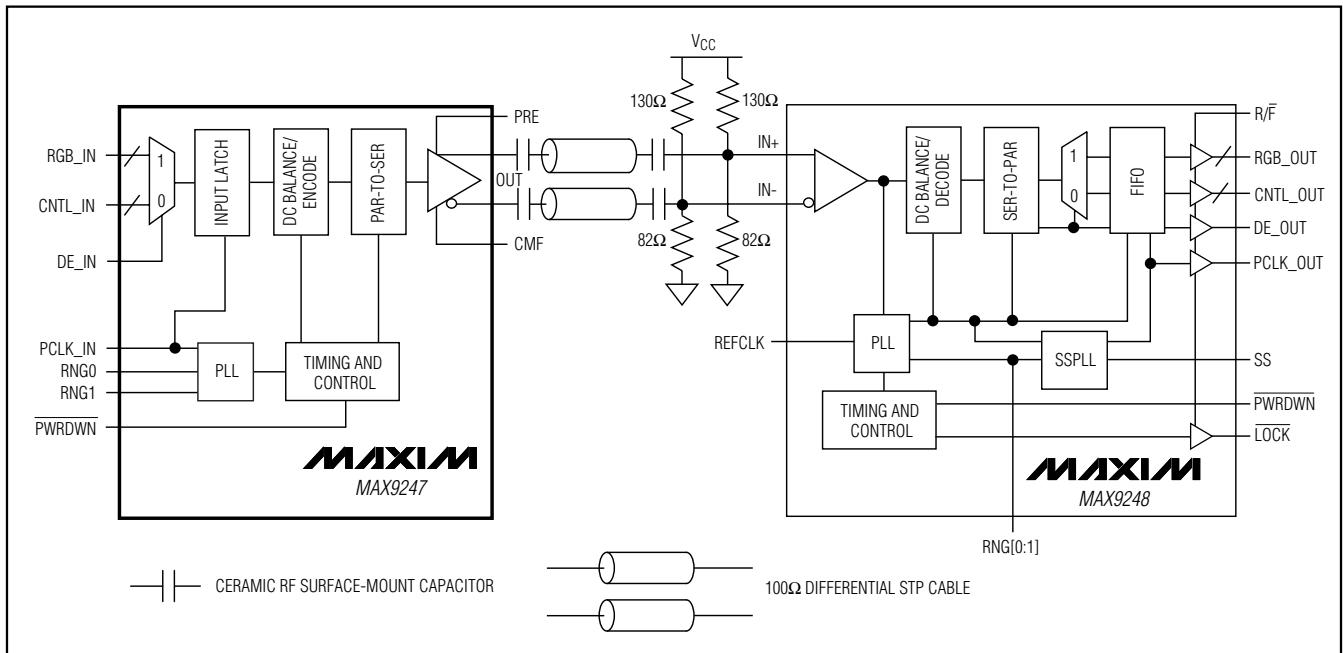

Figure 13. AC-Coupled MAX9247 Serializer and MAX9248 Deserializer with Four Capacitors per Link

27-Bit, 2.5MHz-to-42MHz DC-Balanced LVDS Serializer

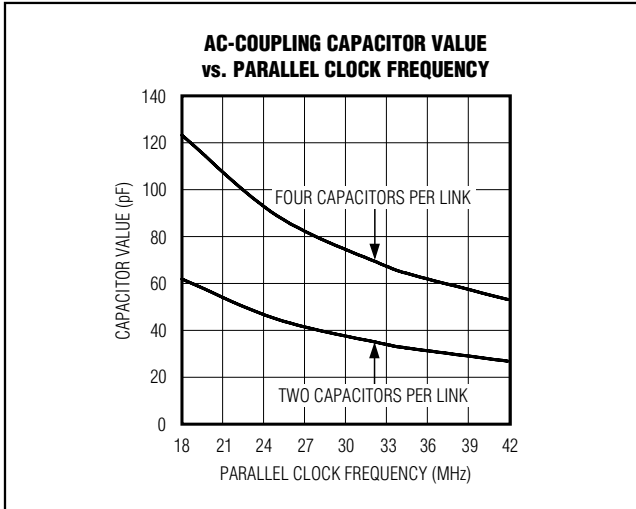

Figure 14. AC-Coupling Capacitor Values vs. Clock Frequency of 18MHz to 42MHz

Termination

The MAX9247 has an integrated 100Ω output-termination resistor. This resistor damps reflections from induced noise and mismatches between the transmission line impedance and termination resistors at the deserializer input. With $\overline{\text{PWRDWN}} = \text{low}$ or with the supply off, the output termination is switched out and the LVDS output is high impedance.

Common-Mode Filter

The integrated 100Ω output termination is made up of two 50Ω resistors in series. The junction of the resistors is connected to the CMF pin for connecting an optional common-mode filter capacitor. Connect the filter capacitor to ground close to the MAX9247 as shown in Figure 15. The capacitor shunts common-mode switching current to ground to reduce EMI.

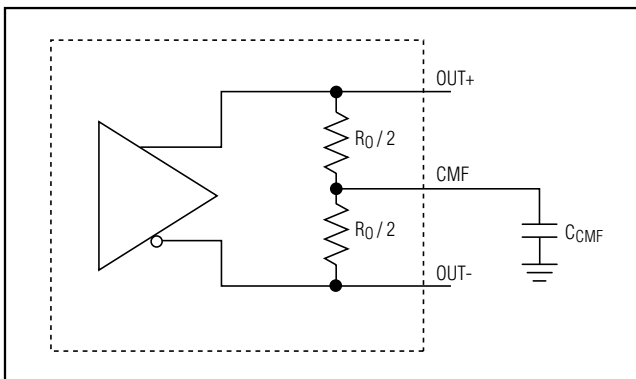

Figure 15. Common-Mode Filter Capacitor Connection

LVDS Output Preemphasis (PRE)

The MAX9247 features a preemphasis mode where extra current is added to the output and causes the amplitude to increase by 40% to 50% at the transition point. Preemphasis helps to get a faster transition, better eye diagram, and improve signal integrity. See the *Typical Operating Characteristics*. The additional current is turned on for a short time (360ps, typ) during data transition, and then turned off. Enable preemphasis by driving PRE high.

Power-Down and Power-Off

Driving $\overline{\text{PWRDWN}}$ low stops the PLL, switches out the integrated 100Ω output termination, and puts the output in high impedance to ground and differential. With $\overline{\text{PWRDWN}} \leq 0.3\text{V}$ and all LVTTTL/LVCMOS inputs $\leq 0.3\text{V}$ or $\geq V_{\text{CCIN}} - 0.3\text{V}$, supply current is reduced to $50\mu\text{A}$ or less.

Driving $\overline{\text{PWRDWN}}$ high starts PLL lock to PCLK_IN and switches in the 100Ω output termination resistor. The LVDS output is not driven until the PLL locks. The LVDS output is high impedance to ground and 100Ω differential. The 100Ω integrated termination pulls OUT+ and OUT- together while the PLL is locking so that $V_{\text{OD}} = 0\text{V}$.

If $V_{\text{CC}} = 0$, the output resistor is switched out and the LVDS outputs are high impedance to ground and differential.

PLL Lock Time

The PLL lock time is set by an internal counter. The lock time is 17,100 PCLK_IN cycles. Power and clock should be stable to meet the lock-time specification.

Input Buffer Supply

The single-ended inputs (RGB_IN[17:0], CNTL_IN[8:0], DE_IN, RNG0, RNG1, PRE, PCLK_IN, and $\overline{\text{PWRDWN}}$) are powered from V_{CCIN} . V_{CCIN} can be connected to a 1.71V to 3.6V supply, allowing logic inputs with a nominal swing of V_{CCIN} . If no power is applied to V_{CCIN} when power is applied to V_{CC} , the inputs are disabled and $\overline{\text{PWRDWN}}$ is internally driven low, putting the device in the power-down state.

Power-Supply Circuits and Bypassing

The MAX9247 has isolated on-chip power domains. The digital core supply (V_{CC}) and single-ended input supply (V_{CCIN}) are isolated but have a common ground (GND). The PLL has separate power and ground (V_{CCPLL} and PLLGND) and the LVDS input also has separate power and ground (V_{CCLVDS} and LVDSGND). The grounds are isolated by diode connections. Bypass each V_{CC} , V_{CCIN} , V_{CCPLL} , and V_{CCLVDS} pin with high-frequency, surface-mount ceramic $0.1\mu\text{F}$ and $0.001\mu\text{F}$ capacitors in parallel as close to the device as possible, with the smallest value capacitor closest to the supply pin.

27-Bit, 2.5MHz-to-42MHz DC-Balanced LVDS Serializer

MAX9247

LVDS Output

The LVDS output is a current source. The voltage swing is proportional to the termination resistance. The output is rated for a differential load of $100\Omega \pm 1\%$.

Cables and Connectors

Interconnect for LVDS typically has a differential impedance of 100Ω . Use cables and connectors that have matched differential impedance to minimize impedance discontinuities.

Twisted-pair and shielded twisted-pair cables offer superior signal quality compared to ribbon cable and tend to generate less EMI due to magnetic field canceling effects. Balanced cables pick up noise as common mode, which is rejected by the LVDS receiver.

Board Layout

Separate the LVTTTL/LVCMOS inputs and LVDS output to prevent crosstalk. A four-layer PC board with separate layers for power, ground, and signals is recommended.

ESD Protection

The MAX9247 ESD tolerance is rated for IEC 61000-4-2, Human Body Model and ISO 10605 standards. IEC 61000-4-2 and ISO 10605 specify ESD tolerance for electronic systems. The IEC 61000-4-2 discharge components are $C_S = 150\text{pF}$ and $R_D = 330\Omega$ (Figure 16).

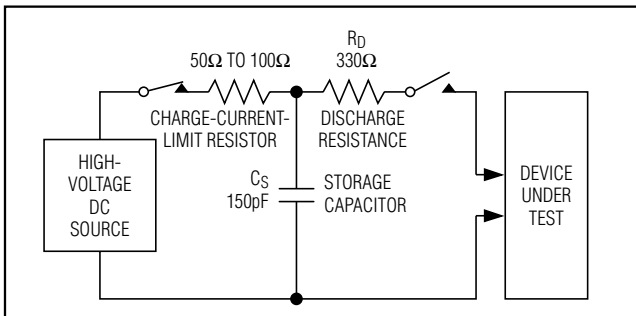

Figure 16. IEC 61000-4-2 Contact Discharge ESD Test Circuit

For IEC 61000-4-2, the LVDS outputs are rated for $\pm 8\text{kV}$ Contact Discharge and $\pm 15\text{kV}$ Air-Gap Discharge. The Human Body Model discharge components are $C_S = 100\text{pF}$ and $R_D = 1.5\text{k}\Omega$ (Figure 17). For the Human Body Model, all pins are rated for $\pm 3\text{kV}$ Contact Discharge. The ISO 10605 discharge components are $C_S = 330\text{pF}$ and $R_D = 2\text{k}\Omega$ (Figure 18). For ISO 10605, the LVDS outputs are rated for $\pm 10\text{kV}$ contact and $\pm 30\text{kV}$ air discharge.

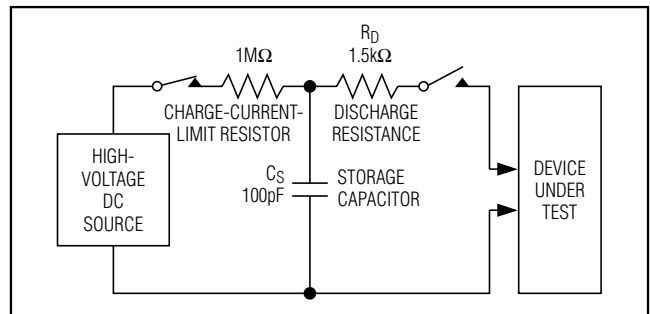

Figure 17. Human Body ESD Test Circuit

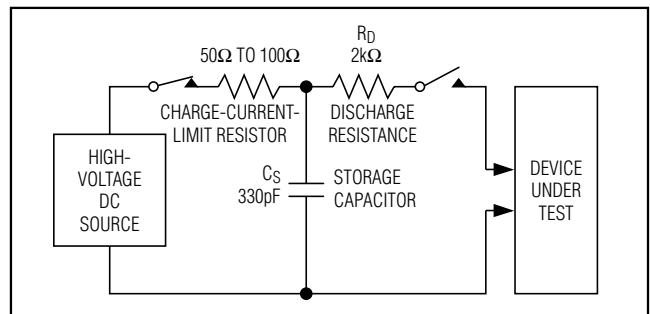

Figure 18. ISO 10605 Contact Discharge ESD Test Circuit

Chip Information

PROCESS: CMOS

27-Bit, 2.5MHz-to-42MHz DC-Balanced LVDS Serializer

Package Information

(The package drawing(s) in this data sheet may not reflect the most current specifications. For the latest package outline information, go to www.maxim-ic.com/packages.)

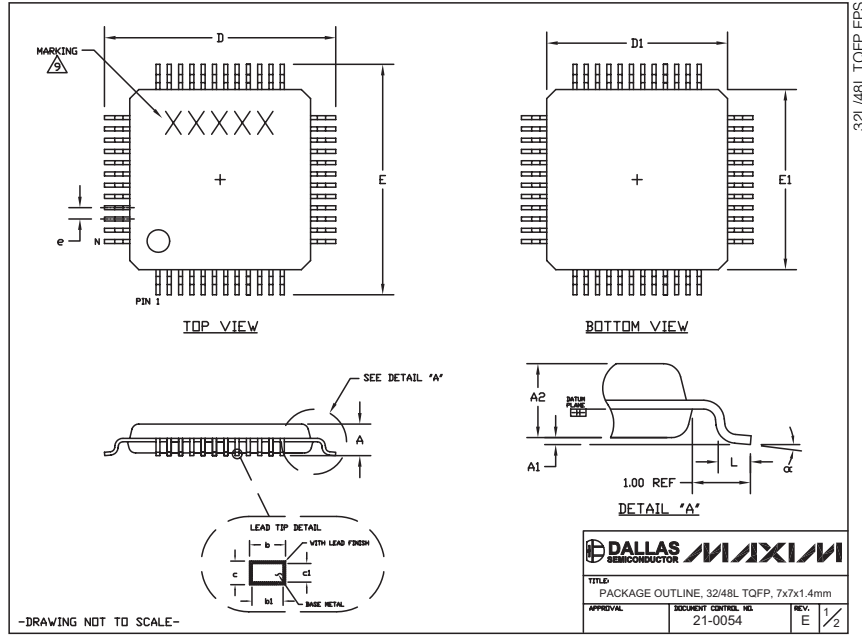

32/48L TOFP.EPS

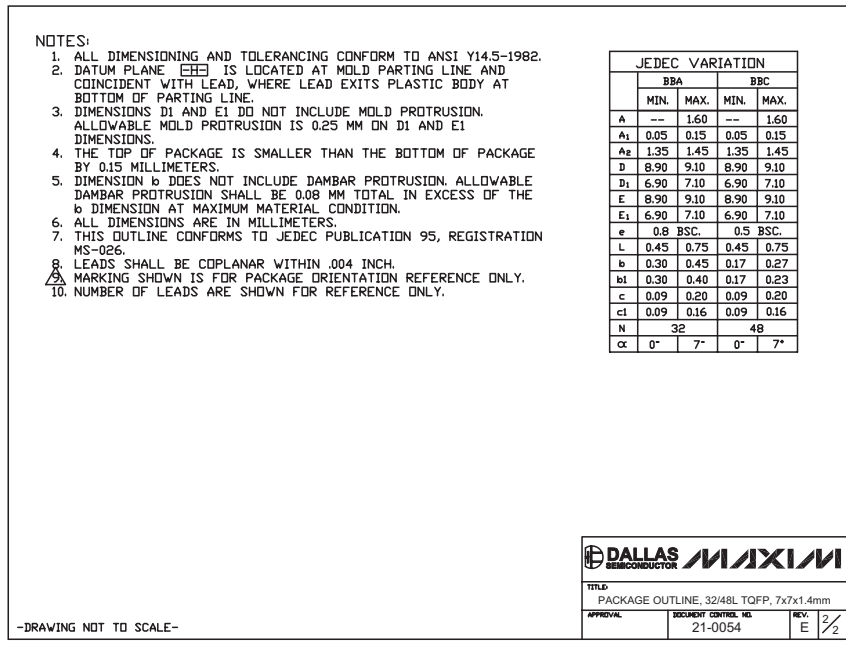

27-Bit, 2.5MHz-to-42MHz DC-Balanced LVDS Serializer

Package Information (continued)

(The package drawing(s) in this data sheet may not reflect the most current specifications. For the latest package outline information, go to www.maxim-ic.com/packages.)

MAX9247

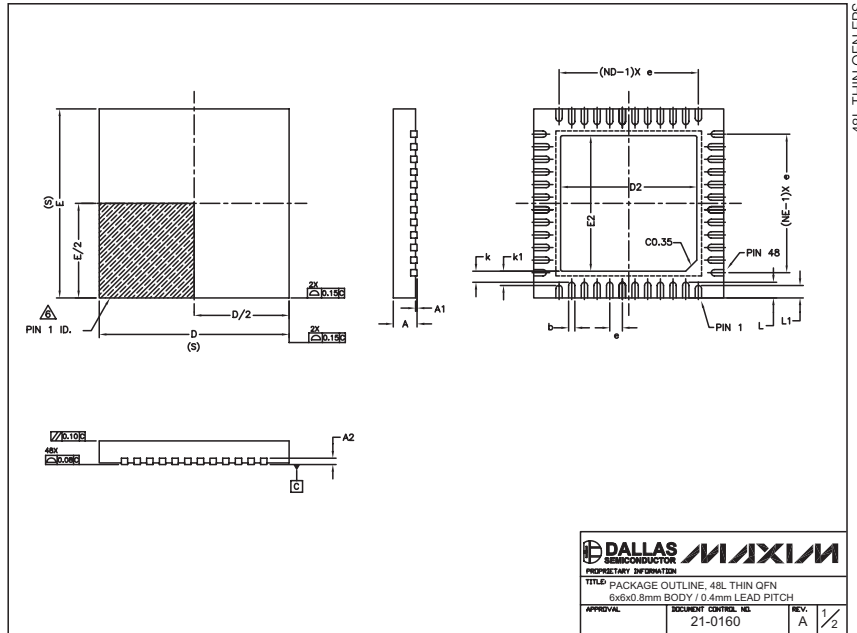

NOTE :

1. ALL DIMENSIONS ARE IN mm. ANGLES IN DEGREES.
2. COPLANARITY APPLIES TO THE EXPOSED PAD AS WELL AS THE TERMINALS. COPLANARITY SHALL NOT EXCEED 0.08mm.
3. WARPAGE SHALL NOT EXCEED 0.10 mm.
4. PACKAGE LENGTH / PACKAGE WIDTH ARE CONSIDERED AS SPECIAL CHARACTERISTIC. (S)
5. REFER TO JEDEC MO-220.
6. THE TERMINAL #1 IDENTIFIER AND TERMINAL NUMBERING CONVENTION SHALL CONFORM TO JESD 95-1 SPP-012. DETAILS OF TERMINAL #1 IDENTIFIER ARE OPTIONAL, BUT MUST BE LOCATED WITHIN THE ZONE INDICATED. THE TERMINAL #1 IDENTIFIER MAY BE EITHER A MOLD OR MARKED FEATURE.
7. ND AND NE REFER TO THE NUMBER OF TERMINALS ON EACH D AND E SIDE RESPECTIVELY.

| COMMON DIMENSIONS | | | |
|-------------------|------------|-------|-------|
| SYMBOLS | MIN. | NOM. | MAX. |
| A | 0.700 | 0.750 | 0.800 |
| A1 | 0.000 | --- | 0.050 |
| A2 | 0.200 REF. | | |
| b | 0.150 | 0.200 | 0.250 |
| D | 5.900 | 6.000 | 6.100 |
| e | 0.400 TYP. | | |
| E | 5.900 | 6.000 | 6.050 |
| k | 0.250 | 0.350 | 0.450 |
| k1 | 0.350 | 0.450 | 0.550 |
| L | 0.400 | 0.500 | 0.600 |
| L1 | 0.300 | 0.400 | 0.500 |
| N | 48 | | |
| ND | 12 | | |
| NE | 12 | | |

| PKG. CODE | EXPOSED PAD VARIATIONS | | | | | |
|-----------|------------------------|------|------|------|------|------|
| | D2 | | | E2 | | |
| | MIN. | NOM. | MAX. | MIN. | NOM. | MAX. |
| T4866-1 | 4.20 | 4.30 | 4.40 | 4.20 | 4.30 | 4.40 |

DALLAS SEMICONDUCTOR **MAXIM**

PROPRIETARY INFORMATION

TITLE PACKAGE OUTLINE, 48L THIN QFN
6x6x0.8mm BODY / 0.4mm LEAD PITCH

| | | |
|----------|---------------------------------|---------------|
| APPROVAL | DOCUMENT CONTROL NO. 21-0160 | REV. A 2/2 |
|----------|---------------------------------|---------------|

Maxim cannot assume responsibility for use of any circuitry other than circuitry entirely embodied in a Maxim product. No circuit patent licenses are implied. Maxim reserves the right to change the circuitry and specifications without notice at any time.

Maxim Integrated Products, 120 San Gabriel Drive, Sunnyvale, CA 94086 408-737-7600 _____ 17