

Power-Control Circuits

Voltage Regulators

**CA723, CA723C
LM723, LM723C**

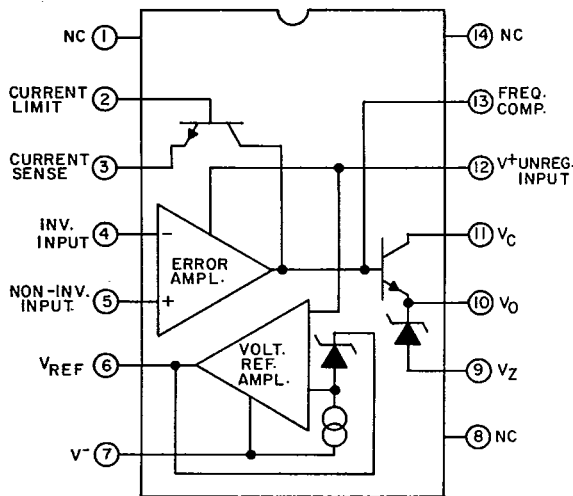

92CS-24158

Features:

- Up to 150 mA output current
- Positive and negative voltage regulation
- Regulation of load currents >150 mA and in excess of 10 A with suitable pass transistors
- Input and output short-circuit protection
- Load and line regulation: 0.03%
- Adjustable output voltage: 2 to 37 V
- Direct replacement for 723 and 723 C industry types

Applications:

- Series and shunt voltage regulator
- Floating regulator
- Switching voltage regulator
- High-current voltage regulator
- Temperature controller

RCA-CA723 and CA723C are silicon monolithic integrated circuits designed for service as voltage regulators at output voltages ranging from 2 to 37 volts at currents up to 150 milliamperes.

Each type includes a temperature-compensated reference amplifier, an error amplifier, a power series pass transistor, and a current-limiting circuit. They also provide independently accessible inputs for adjustable current limiting and remote shutdown and, in addition, feature low standby current drain, low temperature drift, and high ripple rejection.

The CA723 and CA723C may be used with positive and negative power supplies in a wide variety of series, shunt, switching, and floating regulator applications. They can provide regulation at load currents greater than 150 milliamperes and in excess of 10 amperes with the use of suitable n-p-n or p-n-p external pass transistors.

Type No.	Package	Operating Temp. Range
CA723T, CT	10-Lead TO-5	-55 to +125°C
CA723E, CE	14-Lead DIP	
CA723H, CH	Chip	
LM723H, CH	10-Lead TO-5	
LM723N, CN	14-Lead DIP	

Electrical Characteristics at $T_A = 25^\circ\text{C}$, $V_+ = V_C = V_I = 12\text{V}$; $V^- = 0$, $V_O = 5\text{V}$

Type	V_I Range V	V_O Range V	I_O (Max.) mA	Load Regulation (Max.) % V_O	$V_I - V_O$ (Min.) V	Short-Circuit Current Limit mA (Typ.)
CA723	9.5 to 40	2 to 37	150	0.03	3	65
CA723C	9.5 to 40	2 to 37	150	0.03	3	65

• Technical data for LM branded types are identical to the corresponding CA branded types.