

OPTICAL MOUSE SENSOR IC

ATA1088XA

Notice

Some content in the datasheet can be altered without notice

@Lab ATA1088XA

Optical Mouse Sensor Data Sheet



INTRODUCTION

Description

The ATA1088 ("Mighty") is an optical sensor with capability of replacing current track ball mouse of computer system. How the most common optical sensor for mouse works today is: The sensor captures "snapshots" of the work surface at 1,700 times per second, then the captured images are sent to an arithmetic unit to determine direction and magnitude of movement in accordance with speed and acceleration.

However, the key differences in ATA1088 from other optical sensors are that it is designed based on a system level architecture so that it can eliminate side parts resulting in saving extra manufacturing costs. Additionally, PS/2 interface is included within Mighty so that no MCU is need to interface through PS/2. ATA1088 also tolerates to all different magnitudes of movement so that the sensor can be used for design purpose where accuracy is the most important factor as well as for gaming purpose where speed would be the critical factor.

The sensor is in a 24-pin optical DIP package and comes with the default resolution of 400 counts per inch (cpi) and the rate of motion up to 12.75 inches per second.

Features

- Optical navigation technology
- No mechanical parts
- High reliability
- Complete 2-D motion sensor
- High speed motion detection
- Proprietary enhanced navigation accuracy over a wide variety of surfaces
- No precision optical alignment
- Single 5.0 volt power supply
- Low operation current
- PS/2 interface is included
- Power Conservation Mode during times of no movement (No Motion).

Applications

- Mice for desktop PC's, Workstations, and notebook PC's
- Trackballs
- Integrated input devices

Top View of ATA1088XA

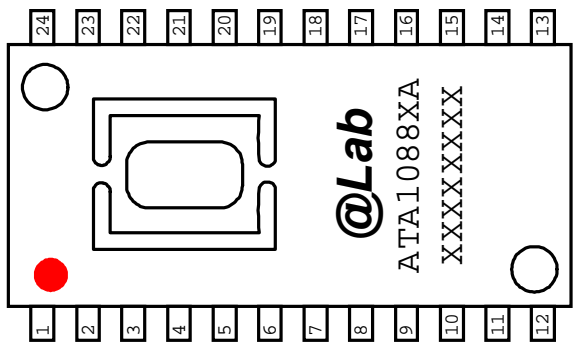

Pinout

Pin	Name	Description
1	TEST1	Reserved/Open (I)
2	TEST2	Reserved/Open (I)
3	TEST3	Reserved/Open (I)
4	TEST4	Reserved / Tied to VDD(I)
5	TEST5	Reserved/Open (I)
6	XY_LED	LED On/Off (O)
7	TEST7	Reserved/Open (I)
8	VDD	Power
9	RESETB	Resetb (I)
10	VSS	Ground
11	WHL_SEL	Mechanical or Optical Wheel Selection (I)
12	PS2_CL	PS2 Clock (I/O)
13	PS2_DA	PS2 Data (I/O)
14	VSS	Ground
15	LB_SW	Left Button (I)
16	VDD	Power
17	Z_A	Wheel A (I)
18	MB_SW	Middle Button (I)
19	Z_B	Wheel B (I)
20	RB_SW	Right Button (I)
21	OSC	Oscillator (I)
22	VSSA	Ground
23	VDDA	Power
24	VDDA	Power

Note: Pin assignments can be altered without notice

ELECTRICAL CHARACTERISTICS

Parameter	Symbol	Unit	Min.	Typ.	Max.	Note
Absolute Maximum Ratings						
Storage Temperature	Tstg	°C	-20		70	
Operating Temperature	Topr	°C	0		50	
Supply Voltage	Vdd	V	-0.5		7.0	
Input Voltage	Vin	V	Vss-0.3		Vdd+0.3	
ESD	-	V	200			All pins, machine model
			2000			All pins, human body model

Recommended Operating Conditions

Operating Temperature	Topr	°C	0	25	40	
Supply Voltage	Vdd	V	4.5	5.0	5.5	
Power Supply Rise Time	Vrt	msec	-	50	100	
Clock Frequency	fclk	MHz		6		
Distance from lens reference plane to surface	D	mm	2.0	2.2	2.4	
Speed	S	Inch/sec	-	-	12.75	

AC Electrical Specification (Recommended operating conditions: Temp=25°C, Vdd=5.0V, and CLK=6MHz)

PS/2 Motion Report Rate		reports /sec	-	100	-	See PS/2 Timing Diagrams
Motion Scale Factor		counts /sec	-	400	-	
Response Time	Trsp1	msec	8.7	10.9	13.1	Movement to data in no motion mode
Power-Up Delay		msec	-	500	-	See R7 and C6 in the application circuit.

DC Electrical Specification (Recommended operating conditions: Temp=25C and Vdd=5.0V)

Supply Current (in Motion)	Idd	mA	-	12	25	
Supply Current (No Motion)	Idd1	mA	-	1.2	2.5	
Input Low Voltage	V _{IL}	V	-	-	0.8	
Input High Voltage	V _{IH}	V	2.0	-	-	
OSC Input Low Voltage	V _{OIL}	V	-	-	1.5	
OSC Input High Voltage	V _{OIH}	V	3.5	-	-	
Output Low Voltage (LED)	V _{OLL}	V	-	0.3	0.5	
Output High Current (LED)	I _{OLED}	mA	1.5	4	6.5	

The following diagram shows a typical application of ATA1088 using Optical wheels.

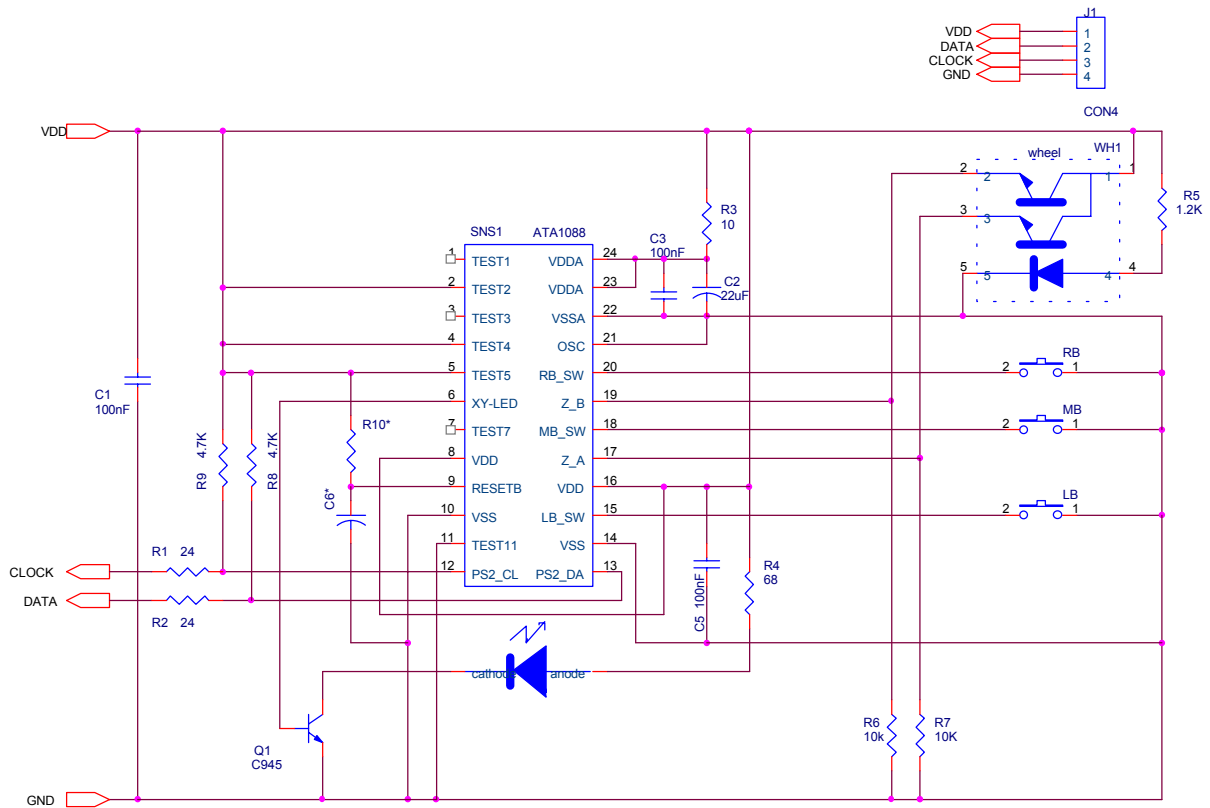

Note1: R7 (=500KΩ) and C6(=2.2μF) is recommended, It should be enough for the motion stabilizing time to be more than 500 msec when power-up.

Note2: To use the Optical wheel, WHL_SEL(Pin11) is connect to Vss.

OPERATIONS

Theory of Operation

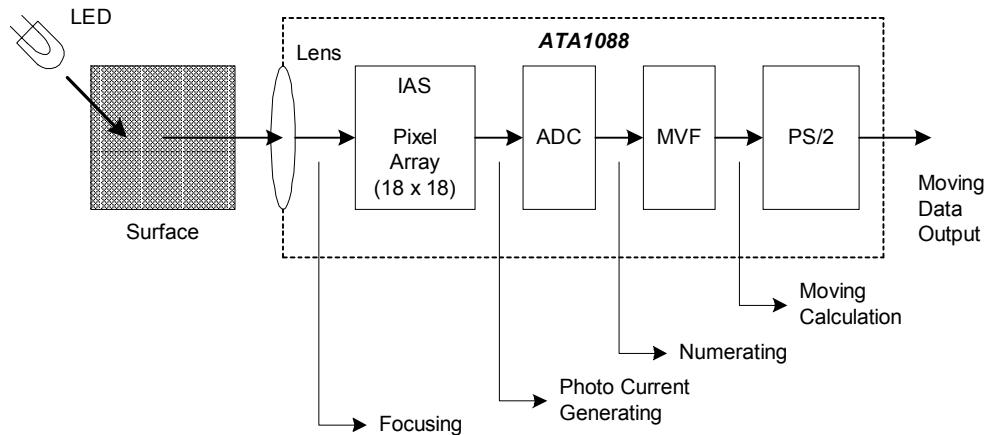

The Mighty is based on Optical Navigation Technology. It contains an Image Acquisition System (IAS), a Motion Vector Finding Processor (MVFP).

The IAS acquires microscopic surface images via the lens and illumination system provided by other parts. These images are processed by the MVF processor to determine the direction and distance of motion. The MVF processor generates the Δx and Δy relative displacement values that are converted into signals in PS/2 format.

No Motion Mode

Once power is up, it requires 500 msec to be stabilized in Motion mode. In order to minimize the power consumption, when there is no motion in the sensor, Mighty turns into no-motion mode.

When there is no motion for one second (default time period) in Motion mode, Mighty turns into No Motion mode.

Timing Diagram in No-Motion Mode

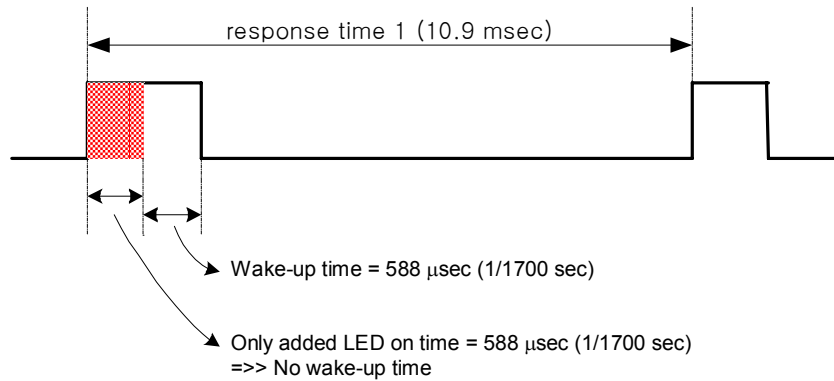

In No Motion mode, Mighty wakes up every 10.9 msec for one report time (588 µsec) and compares with the previous wake-up in order to check whether there is any movement.

PS/2 Command Set

Command (Hex.)	Description	Response
FF	Enter reset mode	FA AA 00
FE	Resend the last data packet to the host NN = last packet(1byte or some bytes)	FA NN
F6	Set default	FA
F5	Disable data reporting	FA
F4	Enable data reporting	FA
F3	Set sample rate (reports/second) NN = {0A, 14, 28, 3C, 50, 64, C8}	FA NN FA
F2	Get device ID NN(Device ID) = 00(without wheel), 03(with wheel)	FA NN
F0	Set remote mode	FA
EE	Set wrap mode	FA
EC	Reset wrap mode and the mouse enters previous mode	FA
EB	Read data in the remote mode Data Packet = See Table1	FA Data Packet
EA	Set stream mode	FA
E9	Status request Status Packet = See Table2	FA Status Packet
E8	Set resolution (counts/mm) NN = {00, 01, 02, 03}	FA NN FA
E7	Set scaling 2:1	FA
E6	Set scaling 1:1	FA

[1] Data Packet

Device ID = 00

	Bit 7	Bit 6	Bit 5	Bit 4	Bit 3	Bit 2	Bit 1	Bit 0
Byte 1	Y overflow	X overflow	Y sign	X sign	Always 1	Middle Btn	Right Btn	Left Btn
Byte 2	X Movement							
Byte 3	Y Movement							

Device ID = 03

	Bit 7	Bit 6	Bit 5	Bit 4	Bit 3	Bit 2	Bit 1	Bit 0
Byte 1	Y overflow	X overflow	Y sign	X sign	Always 1	Middle Btn	Right Btn	Left Btn
Byte 2	X Movement							
Byte 3	Y Movement							
Byte 4	Z Movement (Wheel Movement)							

[2] Status Packet

	Bit 7	Bit 6	Bit 5	Bit 4	Bit 3	Bit 2	Bit 1	Bit 0
Byte 1	Always 0	Mode	Enable	Scaling	Always 0	Left Btn	Middle Btn	Right Btn
Byte 2	Resolution							
Byte 3	Sample Rate							

NOTES : Mode = ‘1’ if remote mode is enabled,
 ‘0’ if stream mode is enabled.

PS/2 Mode Output Waveforms

[1] Timing Diagram for Data Sent from Mighty

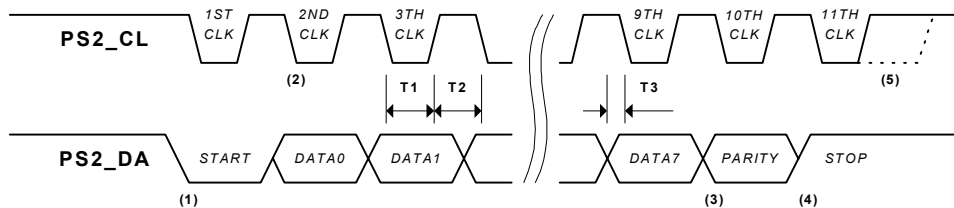

- (1) The mouse checks the clock (PS2_CL) line when it has the data to transmit. If this line is high, the mouse starts data transition with start bit (always 0).
- (2) The host reads data at falling edge of clock signal.
- (3) The parity bit is odd parity.
- (4) The stop bit is always high.
- (5) The host can hold the clock signal low to inhibit next transition.

Parameters	Description	Min. Time	Max. Time
T1	Duration of clock low	24us	48us
T2	Duration of clock high	24us	48us
T3	Time from data transition to falling edge of the clock	12us	24us

[2] Timing Diagram for Data received by Mighty

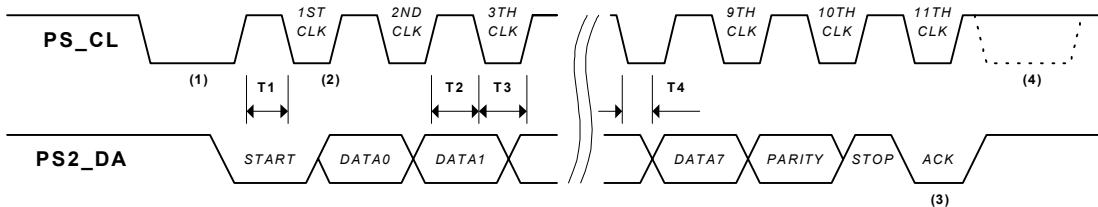

- (1) The host pulls clock signal low to inhibit the mouse, when it has the data to transmit.
- (2) The mouse reads data at rising edge of clock signal.
- (3) The ACK bit is changed when the clock signal is high.
- (4) The host can pull the clock line low to inhibit the mouse.

Parameters	Description	Min. Time	Max. Time
T1	Duration of clock high in the start bit	12us	24us
T2	Duration of clock high	24us	48us
T3	Duration of clock low	24us	48us

Recommended PCB mechanical Drawing (Unit: mm)

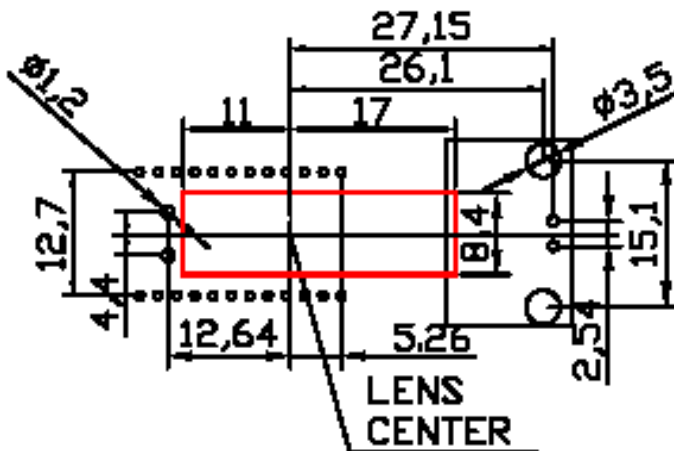

Assembly Drawing (Unit: mm)

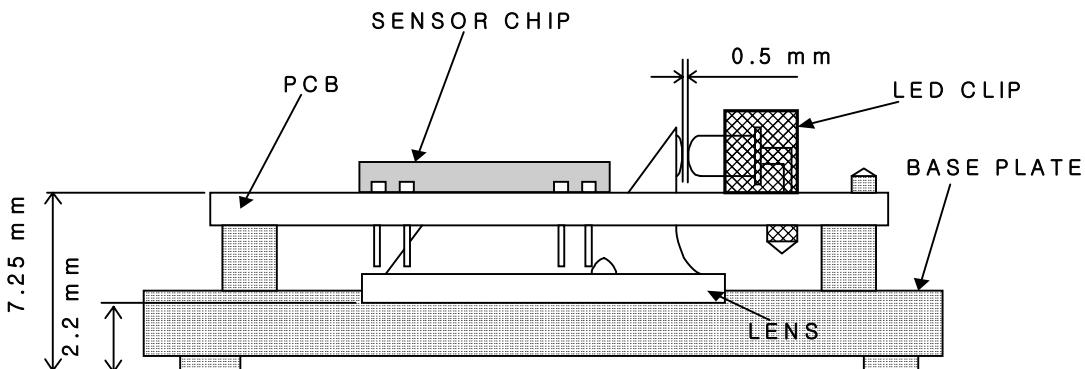
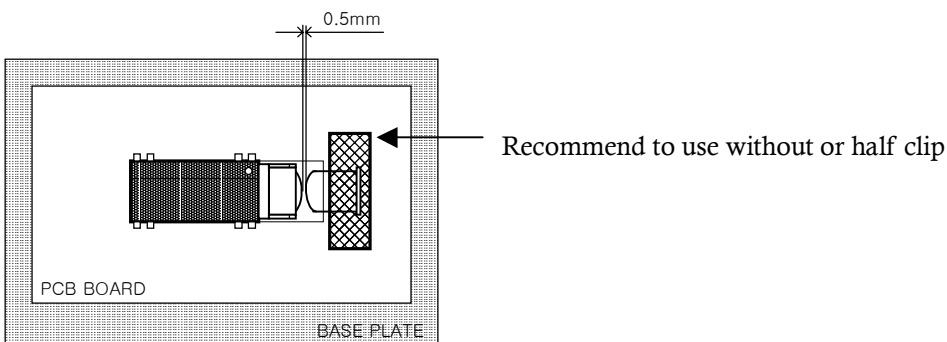

The maximum performance of optical mouse set can be achieved from applying the distances shown above. Lens to surface distance tolerance is $\pm 0.2\text{mm}$

ATA1088 PACKAGE (Unit: mm)

Package Outline Drawing

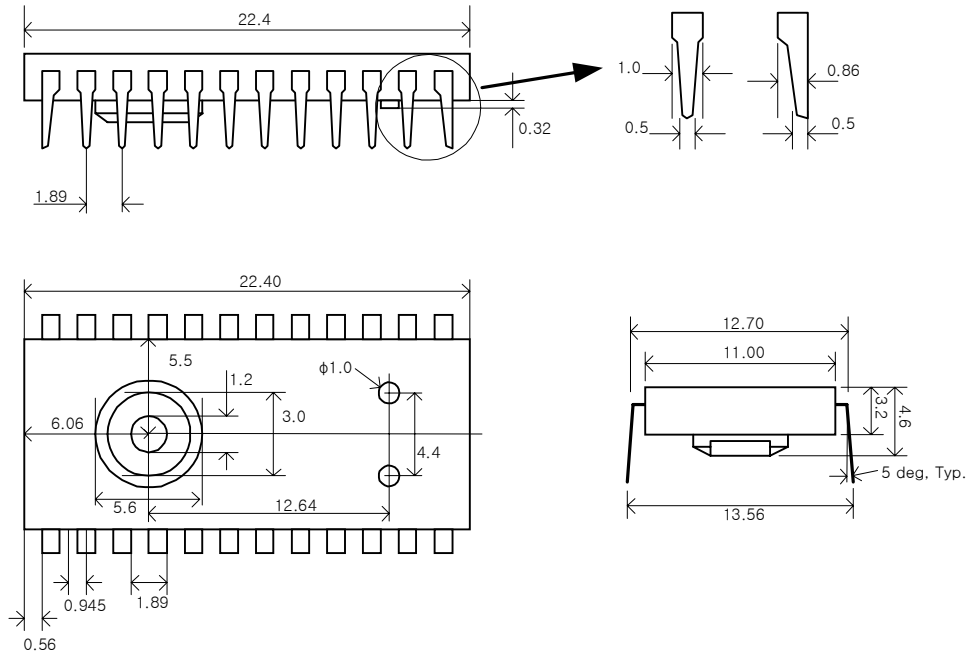

Packaging Information

