

# Advanced Monolithic Systems

## AMSREF-01

*+10V PRECISION VOLTAGE REFERENCE*

### FEATURES

- 10 Volt Output .....  $\pm 0.3\%$  Max
- Adjustment Range .....  $\pm 3\%$  Min
- Excellent Temperature Stability..... 8.5ppm/ $^{\circ}$ C
- Low Noise .....  $30\mu$ V<sub>P-P</sub> Max
- Low Supply Current ..... 650 $\mu$ A Typ
- Wide Input Voltage Range ..... 12V to 40V
- High Load-Driving Capability..... 20mA
- No External Components
- Short -Circuit Proof

### APPLICATIONS

- A/D, D/A Converters
- Portable Instrumentation
- Digital Voltmeters
- Current sources

### GENERAL DESCRIPTION

The AMSREF-01 is a precision voltage reference, which provides a stable +10V output, which can be adjusted over a  $\pm 3\%$  range with minimal effect on temperature stability. Careful design of this device improved its bandgap and as a result excellent temperature stability is achieved. The operating supply range is 12V to 40V with a typical current drain of 650 $\mu$ A. Low cost, low noise and low power makes the AMSREF-01 an excellent choice whenever a stable voltage reference is required. Applications include D/A and A/D converters, portable instrumentation and digital voltmeters.

The AMSREF-01 is operational in the full industrial temperature range of -40 $^{\circ}$ C to +85 $^{\circ}$ C and is available in the 8 lead SOIC and plastic dip (PDIP) packages.

### ORDERING INFORMATION:

TOL.	PACKAGE TYPE		OPERATING TEMPERATURE RANGE
	8 LEAD SOIC	8 LEAD PDIP	
$\pm 30$ mV	AMSREF-01ES	AMSREF-01EP	-40 to 85 $^{\circ}$ C
$\pm 50$ mV	AMSREF-01HS	AMSREF-01HP	-40 to 85 $^{\circ}$ C
$\pm 100$ mV	AMSREF-01CS	AMSREF-01CP	-40 to 85 $^{\circ}$ C

### PIN CONNECTIONS

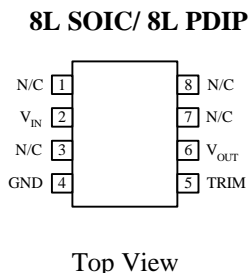

# AMSREF-01

## ABSOLUTE MAXIMUM RATINGS (Note1)

Input Voltage	40V	Storage temperature	-65°C to +125°C
Output Short Circuit Duration (to Ground or $V_{IN}$ )	Indefinite	Soldering information (60 sec)	300°C
Operating Temperature Range	-40°C to 85°C	Thermal Resistance	
Junction Temperature	-65°C to +150°C	8 L SOIC	160°C/W
		8 L PDIP	110°C/W

## ELECTRICAL CHARACTERISTICS

Electrical Characteristics at  $V_{IN} = +15V$  and  $T_A = +25^\circ C$  unless otherwise specified.

Parameter	Conditions	AMSREF-01E			AMSREF-01 H			AMSREF-01 C			Units
		Min	Typ	Max	Min	Typ	Max	Min	Typ	Max	
Output Voltage	$I_L = 0$	9.97	10.0	10.03	9.95	10.0	10.05	9.90	10.0	10.10	V
Output Adjustment Range	$R_P = 10k\Omega$	$\pm 3.0$	$\pm 3.3$		$\pm 3.0$	$\pm 3.3$		$\pm 2.7$	$\pm 3.3$		%
Output Voltage Noise	0.1Hz to 10Hz		20	30		20	30		25	35	$\mu V_{P-P}$
Line Regulation (Note 5)	$V_{IN} = 13V$ to 33V		0.006	0.010		0.006	0.010		0.009	0.015	% V
Load Regulation (Note 5)	$I_L = 0$ to 10 mA,		0.005	0.008		0.006	0.010		0.006	0.015	% mA
Turn-on Setting Time	$T_O \pm 0.1\%$ of final value		5			5			5		$\mu s$
Quiescent Supply Current	No Load		0.65	1.0		0.65	1.0		0.65	1.0	mA
Load Current		10	21		10	21		8	21		mA
Sink Current	(Note 6)	-5	-10		-5	-10		-5	-10		mA
Short Circuit Current	$V_O = 0$		30			30			30		mA

## ELECTRICAL CHARACTERISTICS

Electrical Characteristics at  $V_{IN} = 15$ ,  $I_L = 0mA$ , and  $-40^\circ C \leq T_A \leq +85^\circ C$  unless otherwise specified.

Parameter	Conditions	AMSREF-01E			AMSREF-01 H			AMSREF-01 C			Units
		Min	Typ	Max	Min	Typ	Max	Min	Typ	Max	
Output Voltage Change with Temp.	(Notes 2,3)		0.02	0.06		0.07	0.17		0.14	0.45	%
Output Voltage Temp. Coefficient	(Note 4)		3	8.5		10	25		20	65	ppm/°C
Change in $V_O$ Temp. Coefficient with Output Adjustment	$R_L = 10k\Omega$		0.7			0.7			0.7		ppm/°C
Line Regulation (Note 5)	$V_{IN} = 13V$ to 33V		0.007	0.012		0.007	0.012		0.011	0.018	% V
Load Regulation (Note 5)	$I_L = 0$ to 8 mA,		0.006	0.010		0.007	0.012		0.008	0.018	% mA

**Note 1:** Absolute Maximum Ratings indicate limits beyond which damage to the device may occur. Operating Ratings indicate conditions for which the device is intended to be functional, but do not guarantee specific performance limits. For guaranteed specifications and test conditions, see the Electrical Characteristics. The guaranteed specifications apply only for the test conditions listed.

**Note 2:** The output voltage change with temperature ( $\Delta V_{OT}$ ) is defined as the absolute difference between the maximum output voltage and the minimum output voltage over the specified temperature range expressed as a percentage of 10V:

$$\Delta V_{OT} = [(V_{MAX} - V_{MIN}) / 10V] \times 100$$

**Note 3:**  $\Delta V_{OT}$  specification applies trimmed to +10.000V or untrimmed

**Note 4:**  $TCV_O$  is defined as  $\Delta V_{OT}$  divided by the temperature range:  $TCV_O (-40^\circ C \text{ to } +85^\circ C) = [\Delta V_{OT} (-40^\circ C \text{ to } +85^\circ C)] / 125^\circ C$

**Note 5:** Line and Load Regulation specifications include the effect of self heating.

**Note 6:** During sink current test, the device meets the output voltage specified.

## TYPICAL PERFORMANCE CHARACTERISTICS

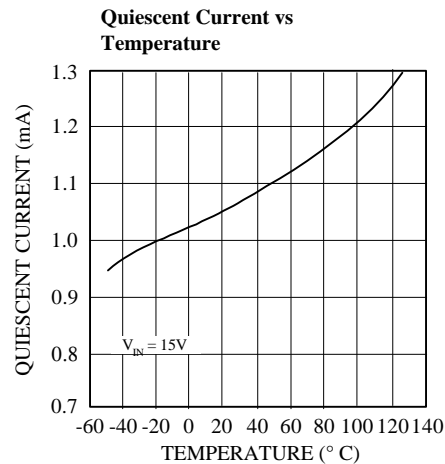
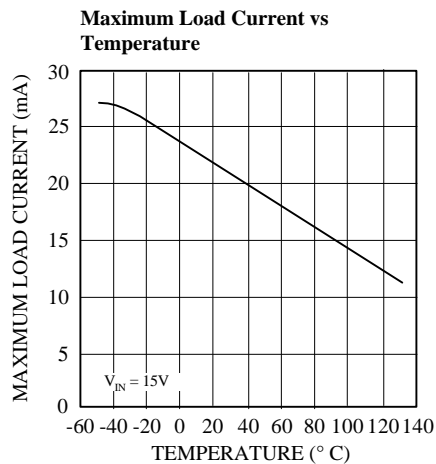
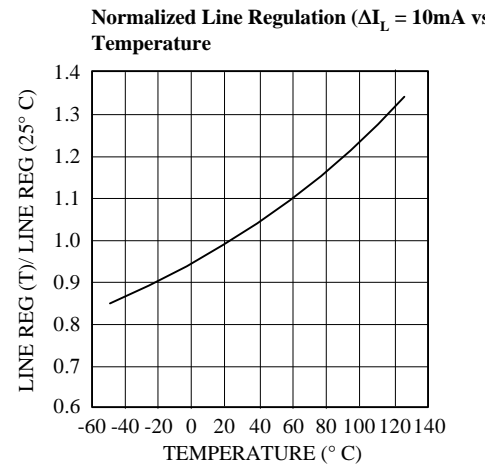
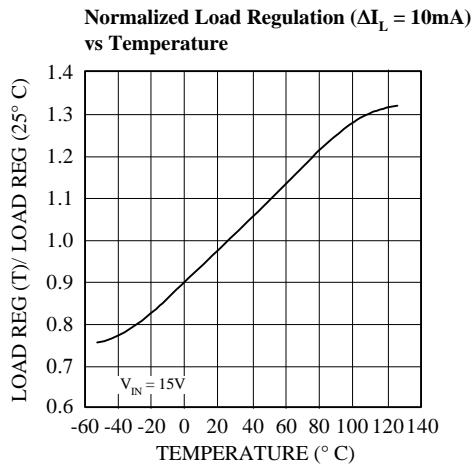
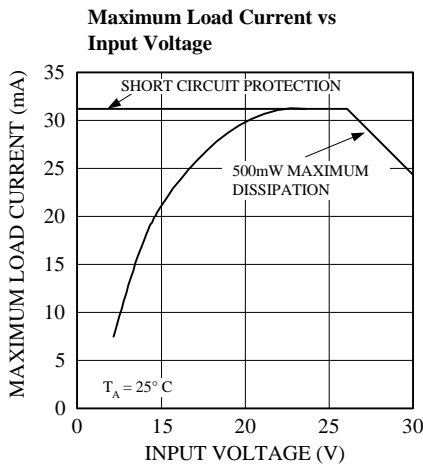

## OUTPUT ADJUSTMENT

The REF-01 trim terminal can be used to adjust the 10V output voltage  $\pm 300\text{mV}$ . This feature allows the system designer to trim system errors by setting the reference to a voltage other than 10V. The system can also be set exactly 10.000V, or to 10.240V for binary applications.

Adjustment of the output does not significantly affect the temperature performance of the device. The temperature coefficient change is approximately  $0.7\text{ppm}/^\circ\text{C}$  for 100mV of output adjustment.

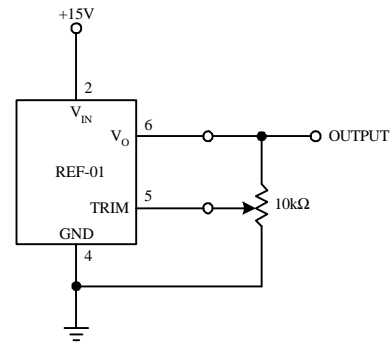

## TYPICAL APPLICATIONS

**$\pm 10\text{V}$  Reference**

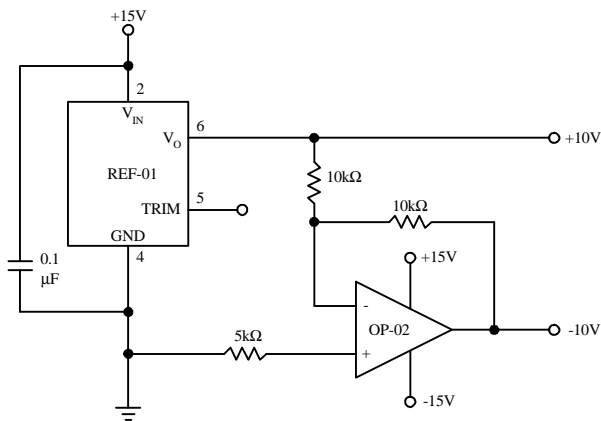

**Precision Calibration Standard**

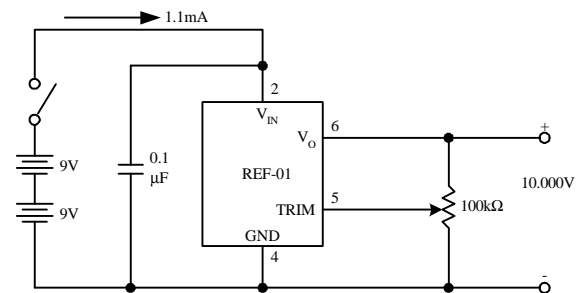

### Supply Bypassing

For best results, it is recommended that the power supply pin is bypassed with a  $0.1\mu\text{F}$  disk ceramic capacitor.

**Current Source**

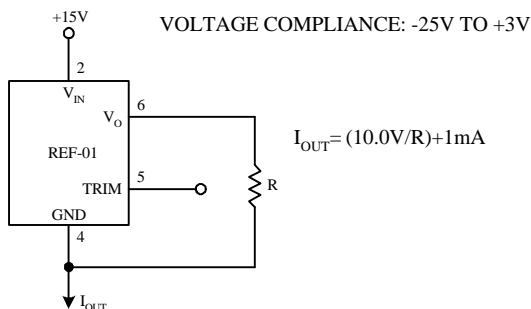

**Current Sink**

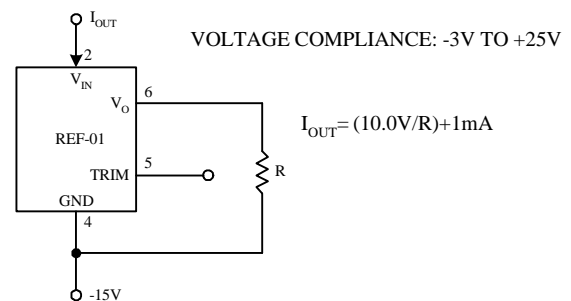

PACKAGE DIMENSIONS inches (millimeters) unless otherwise noted.

## 8 LEAD SOIC PLASTIC PACKAGE (S)

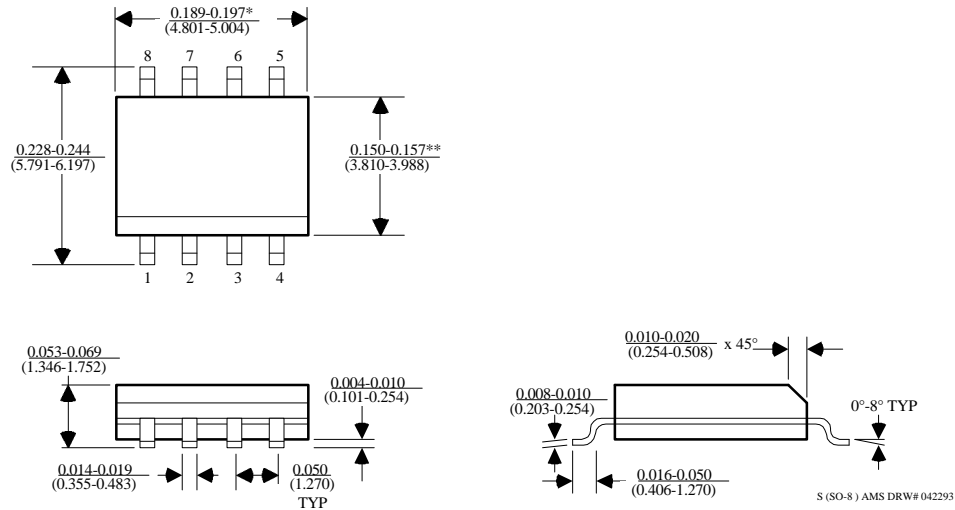

\*DIMENSION DOES NOT INCLUDE MOLD FLASH. MOLD FLASH SHALL NOT EXCEED 0.006" (0.152mm) PER SIDE

\*\*DIMENSION DOES NOT INCLUDE INTERLEAD FLASH. INTERLEAD FLASH SHALL NOT EXCEED 0.010" (0.254mm) PER SIDE

## 8 LEAD PLASTIC DIP PACKAGE (P)

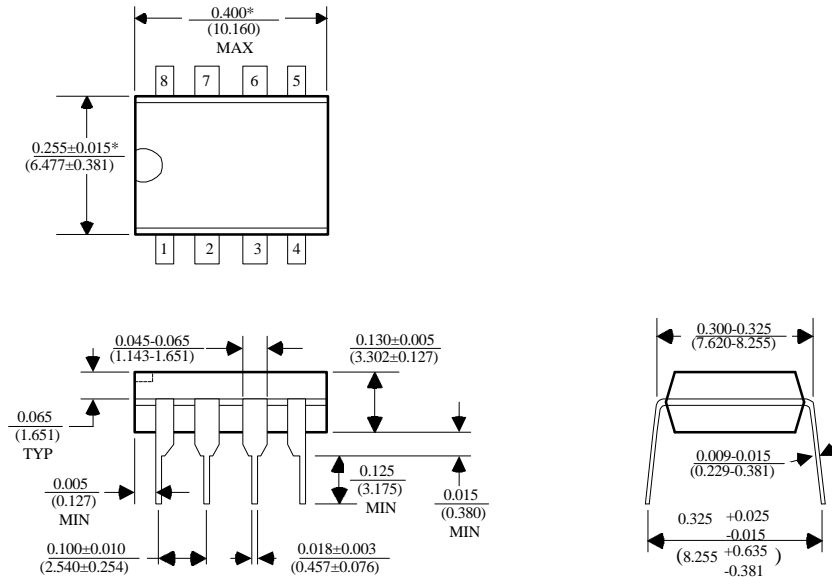

\*DIMENSIONS DO NOT INCLUDE MOLD FLASH OR PROTUSIONS. MOLD FLASH OR PROTUSIONS SHALL NOT EXCEED 0.010" (0.254mm)