

Hot-Insertable Active SCSI Terminator

GENERAL DESCRIPTION

The ML6599 BiCMOS 9 line SCSI terminator provides active termination in SCSI systems using single ended drivers and receivers. Active SCSI termination helps to effectively control analog transmission line effects such as ringing, noise, crosstalk, and ground bounce. In addition, the ML6599 provides support for hot-insertability on the SCSI bus.

The ML6599 provides a V-I characteristic optimized to minimize transmission line effects during both signal negation and assertion using a MOSFET-based architecture. The desired V-I characteristic is achieved by trimming one resistor in the control block. Internal clamping controls signal assertion transients and provides current sink capability to handle active negation driver overshoots above 2.85V. It provides a 2.85V reference through an internal low dropout (1V) linear regulator.

The ML6599 also provides a disconnect function which effectively removes the terminator from the SCSI bus. The disconnect mode capacitance is typically less than 5pF per line. Current limiting and thermal shutdown protection are also included.

FEATURES

- Fully monolithic IC solution providing active termination for 9 lines of the SCSI bus
- Provides on board support for hot-insertability on the SCSI bus
- Low dropout voltage (1V) linear regulator, trimmed for accurate termination current
- Output capacitance typically < 5pF
- Disconnect mode — logic pin to disconnect terminator from the SCSI bus, <100μA
- Current sinking — can sink current in excess of 10mA per line to handle active negation driver overshoots above 2.85V
- Negative clamping on all lines to handle signal assertion transients
- Regulator can source 200mA and sink 100mA while maintaining regulation
- Current limit & thermal shutdown protection

**Some Packages Are Obsolete*

BLOCK DIAGRAM

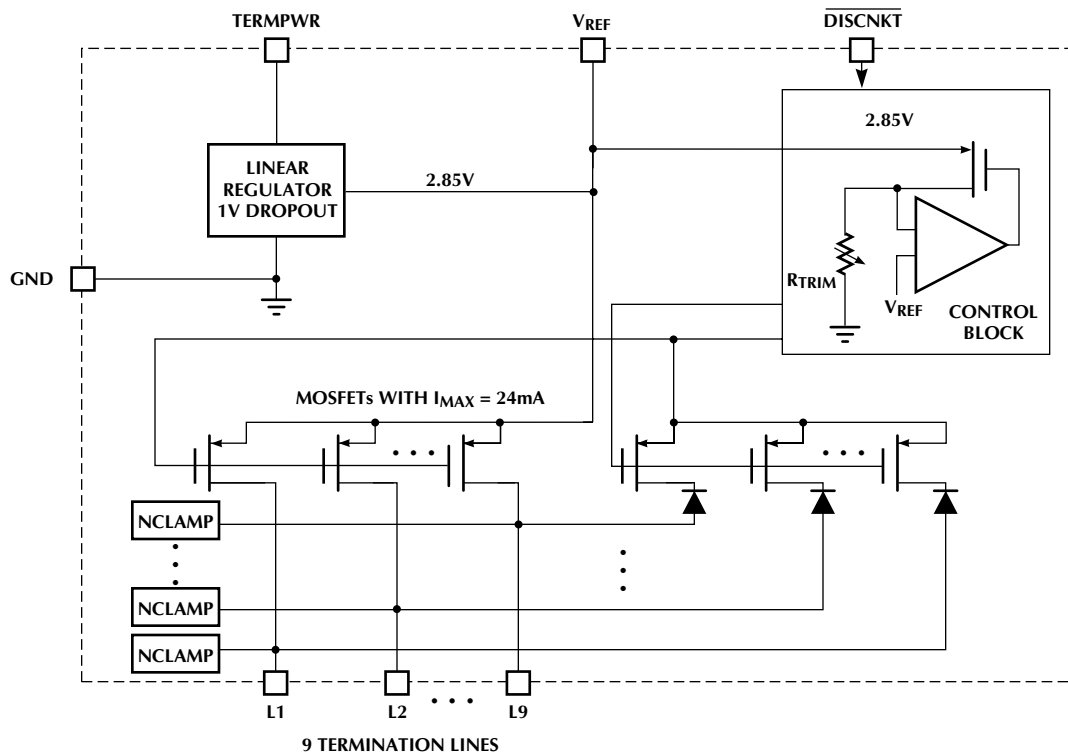

NCLAMP = Negative Clamp

PIN CONFIGURATION

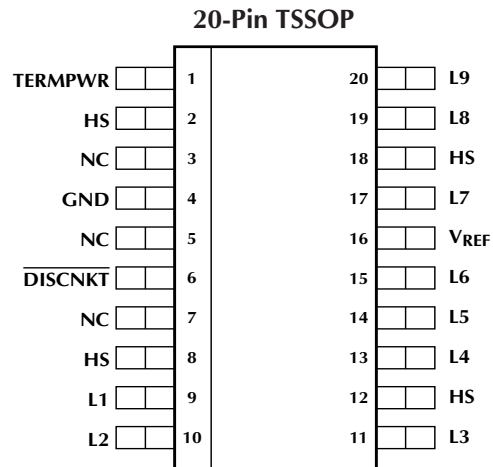
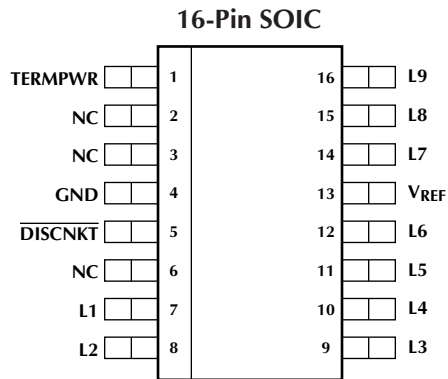

PIN DESCRIPTION

NAME	DESCRIPTION
TEMPWR	Termination Power. Should be connected to the SCSI TEMPWR line. A 10 μ F tantalum local bypass capacitor is recommended per system, as shown in the application diagram
L1	Signal Termination 1. SCSI Bus line 1
L2	Signal Termination 2. SCSI Bus line 2
L3	Signal Termination 3. SCSI Bus line 3
L4	Signal Termination 4. SCSI Bus line 4
L5	Signal Termination 5. SCSI Bus line 5
L6	Signal Termination 6. SCSI Bus line 6
L7	Signal Termination 7. SCSI Bus line 7
L8	Signal Termination 8. SCSI Bus line 8
L9	Signal Termination 9. SCSI Bus line 9

NAME	DESCRIPTION
V _{REF}	2.85V _{REF} Output. External decoupling with a 10 μ F tantalum in parallel with a 0.1 μ F ceramic capacitor is recommended, as shown in the application diagram.
DISCNKT	Disconnect Terminator. Logic input to disconnect the terminator from the bus when the SCSI device no longer needs termination due to not being the last device on the bus or otherwise. Active low input.
GND	Ground. Signal ground (0V)
HS	Heat Sink Ground. Should be connected to GND.

NOTE: The DISCNKT line has a 200k Ω internal pullup resistor connected to the supply. This pin should be left floating for normal operation and should be connected to ground to enable the function.

ABSOLUTE MAXIMUM RATINGS

Signal Line Voltage	-0.3 to TERMPWR + 0.3V
Regulator Output Current	-100 to 300mA
TERMPWR Voltage	-0.3 to 7V
Storage Temperature	-65°C to 150°C
Soldering Temperature	260°C for 10s
Thermal Impedance (θ_{JA})	
SOIC	95°C/W
TSSOP	110°C/W

OPERATING CONDITIONS

TERMPWR Voltage	4V to 5.25V
Operating Temperature	0°C to 70°C

ELECTRICAL CHARACTERISTICS

Unless otherwise stated, these specifications apply for $4V \leq \text{TERMPWR} \leq 5.25V$, and $T_A = 0^\circ\text{C}$ to 70°C (Note 1)

PARAMETER	CONDITIONS	MIN	TYP	MAX	UNITS
Supply					
TERMPWR Supply Current	L1–L9 = open, $\overline{\text{DISCNKT}}$ = open		4.5	5.5	mA
	L1–L9 = 0.2 V, $\overline{\text{DISCNKT}}$ = open		225	250	mA
Disconnect Mode Current	$\overline{\text{DISCNKT}}$ = 0 (active)		75	100	μA
$\overline{\text{DISCNKT}}$					
Input Low Voltage				1.0	V
Input High Voltage		TERMPWR – 1.0			V
Output					
Output High Voltage	Measuring each signal line while other eight are high	2.8	2.85	2.9	V
Output Current (Normal Mode)	$V_{\text{OUT}} = 0.2V$, Measuring each signal line while the other eight are high	20		24	mA
Hot Insertion Peak Current	TERMPWR = 0V, $V_{\text{REF}} = 0V$ Any signal line (L1–L9) at 2.85V		1	2	μA
Output Clamp Level	$I_{\text{OUT}} = -30\text{mA}$ (Note 2)	-0.15	0	0.15	V
Sinking Current (per line)	$V_{\text{OUT}} = 3.3V$ (per line)	10	12		mA
Output Capacitance (Micro Linear Method)	L1 thru L9, $\overline{\text{DISCNKT}} = 0$ 2V _{p-p} 100kHz square wave applied biased at 1V D.C.		4	5	pF
Output Capacitance (X3T9.2/855D method)	L1 thru L9, $\overline{\text{DISCNKT}} = 0$ 0.4V _{p-p} , 1MHz square wave applied biased at 0.5V D.C.		6	7	pF
Regulator					
Output Voltage	Sourcing 0-200mA	2.8	2.85	2.9	V
	Sinking 0-100mA	2.8	2.85	2.9	V
Sinking Current	$V = 3.5V$	125	150		mA
Short Circuit Current	$V_{\text{REF}} = 0V$		150		mA
	$V_{\text{REF}} = 5V$		300		mA
Dropout Voltage	L1–L9 = 0.2V		1.0	1.2	V
Thermal Shutdown			170		°C

Note 1: Limits are guaranteed by 100% testing, sampling, or correlation with worst case test conditions.

FUNCTIONAL DESCRIPTION

SCSI terminators are used to decrease the transmission line effects of SCSI cable. Termination must be provided at the beginning and end of the SCSI bus to ensure that data errors due to reflections on the bus are eliminated. With the increasing use of higher data rates and cable lengths in SCSI subsystems, active termination has become necessary. Active termination also minimizes power dissipation and can be activated or deactivated under software control, thus eliminating the need for end user intervention. The V-I characteristics of popular SCSI termination schemes are shown in Figure 1. Theoretically, the desired V-I characteristics are the Boulay type for signal assertion (high to low) and the ideal type for signal negation (low to high). The ML6599 with its MOSFET-based nonlinear termination element provides the most optimum V-I characteristics for both signal assertion and negation.

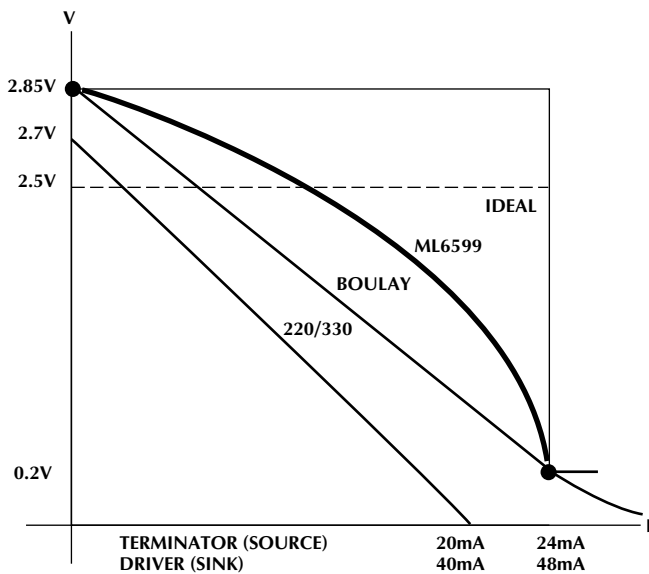

Figure 1. V-I Characteristics of Various SCSI Termination Schemes

The ML6599 provides active termination for 9 signal lines, thus accommodating basic SCSI which requires 9 lines to be terminated. When used with the ML6599, wide SCSI, which requires 27, 36 or 45 lines to be terminated, can also be accommodated. The ML6599 integrates an accurate voltage reference (1V dropout voltage) and 9 MOSFET-based termination lines. A single internal resistor is trimmed to tune the V-I characteristic of the MOSFETs. The voltage reference circuit produces a precise 2.85V level and is capable of sourcing 24mA into each of the nine terminating lines when low (active). When the signal line is negated (driver turns off), the terminator pulls the signal line back to 2.85V. The regulator will source 200mA and sink 100mA while maintaining regulation of 2.85V.

The ML6599 SCSI terminator provides an active low control signal (DISCNKT) which has an internal 200k Ω pull-up resistor. The DISCNKT input isolates the ML6599 from the signal lines and effectively removes the terminator from the SCSI bus with a disconnect mode current of less than 100 μ A when pulled low. In addition, the ML6599 provides for negative clamping of signal transients and also supports current sink capability in excess of 10mA per signal line to handle active negation driver overshoot above 2.85V, a common occurrence with SCSI transceivers.

Disconnect mode capacitance is a very critical parameter in SCSI systems. The ML6599 provides a capacitance contribution of only 5pF.

HOT-INSERTABILITY

“Hot” insertion of a SCSI device refers to the act of plugging a SCSI device which is initially unpowered into a powered SCSI bus. The SCSI device subsequently draws power from the TERMPWR line during its startup routine and thereafter. “Hot” removal refers to the act of removing a powered SCSI device from a powered SCSI bus. A device which performs both tasks with no physical damage to itself or other devices on the bus, nor which alters the existing state of the bus by drawing excessive currents, is termed “hot-swappable.”

The ML6599 hot-insertable SCSI terminator typically draws 1 μ A from any given output line (L1–L9) during a hot-insertion/removal procedure, thereby protecting itself and preserving the state of the bus. The low insertion current is achieved by effectively shorting the gate to drain of the output PMOS device until the 2.85V reference (V_{REF}) has powered up. A second PMOS in series with a Schottky diode is used as the shorting bypass device. After V_{REF} reaches a sufficient level, the bypass device is turned off and the part operates normally. Figure 2 gives an application diagram showing a typical SCSI bus configuration. To ensure proper operation, the TERMPWR pin must be connected to the SCSI TERMPower line. As outlined in Annex G of the ANSI SCSI-3 Parallel Interface Specification (X3T9.2/855D), “The SCSI bus termination shall be external to the device being inserted or removed.” In other words, any terminator connected to a device

being hot-inserted/removed should be inactive (accomplished by grounding the DISCNKT pin in the case of the ML6599). If the terminator being inserted/removed were in the active state, at some point in time the bus would be terminated by either 1 or 3 terminators. In either case, data integrity on the bus will be compromised.

Figure 2 gives an application diagram showing a typical SCSI bus configuration. To ensure proper operation, the TERMPWR pin must be connected to the SCSI TERMPWR line. Each ML6599 requires parallel 0.1µF and 10µF capacitors connected between the V_{REF} and GND pins and the TERMPWR line needs a 10µF bypass capacitor at each node in the system.

In an 8-bit wide SCSI bus arrangement ("A" Cable), two ML6599s would be needed at each end of the SCSI cable in order to terminate the 9 active signal lines. 16-bit wide SCSI would use three ML6599s, while 32-bit wide SCSI bus would require five ML6599s.

In a typical SCSI subsystem, the open collector driver in the SCSI transceiver pulls low when asserted. The

termination resistance serves as the pull-up when negated. Figure 2 also shows a typical cable response to a pulse. The receiving end of the cable will exhibit a single time delay. When negated, the initial step will reach an intermediate level (V_{STEP}). With higher SCSI data rates, sampling could occur during this step portion. In order to get the most noise margin, the step needs to be as high as possible to prevent false triggering. For this reason the regulator voltage and the resistor defining the MOSFET characteristic are trimmed to ensure that the I_O is as close as possible to the SCSI maximum current specification. V_{STEP} is defined as:

$$V_{STEP} = V_{OL} + (I_O \times Z_O)$$

where V_{OL} is the driver output low voltage, I_O is the current from the receiving terminator, and Z_O is the characteristic impedance of the cable.

This is a very important characteristic that the terminator helps to overcome by increasing the noise margin and boosting the step as high as possible.

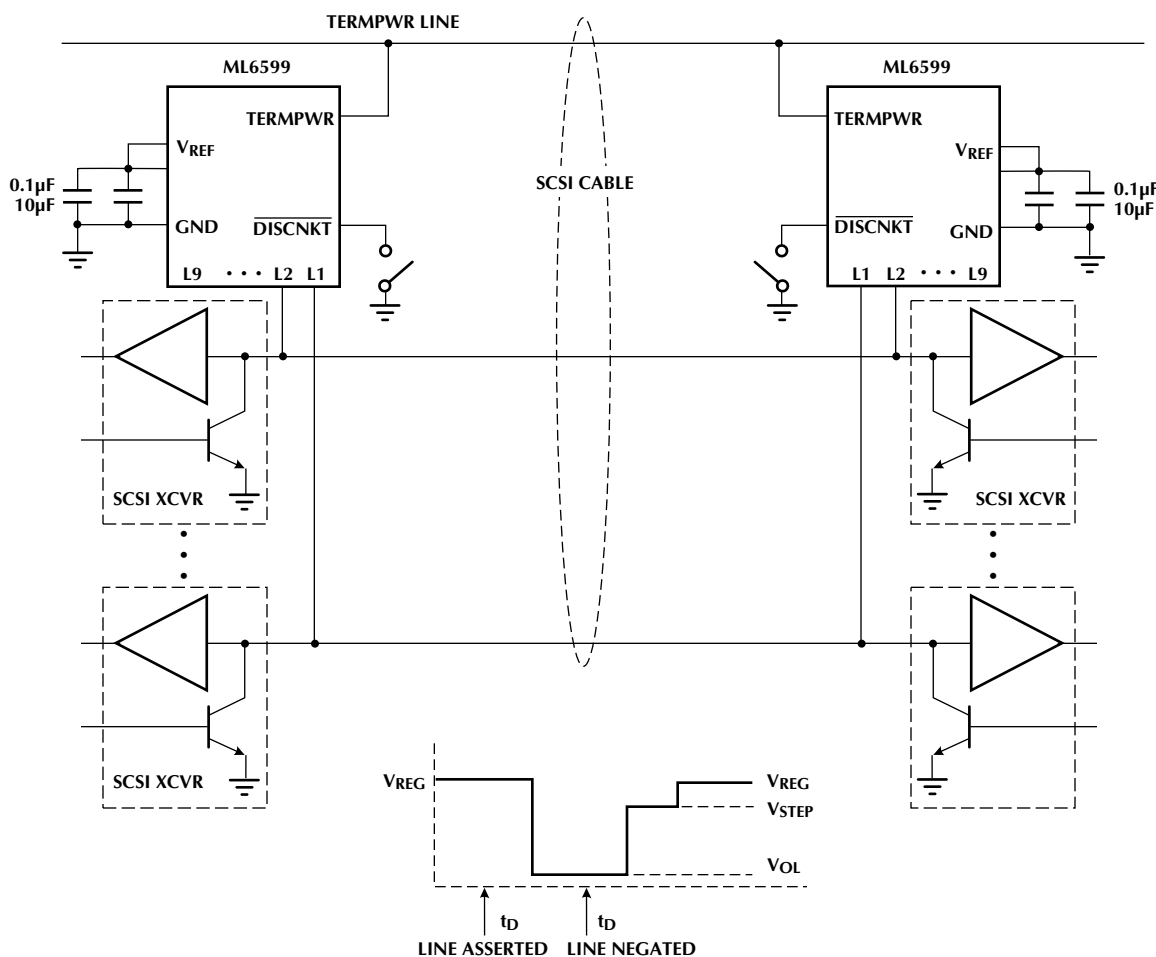
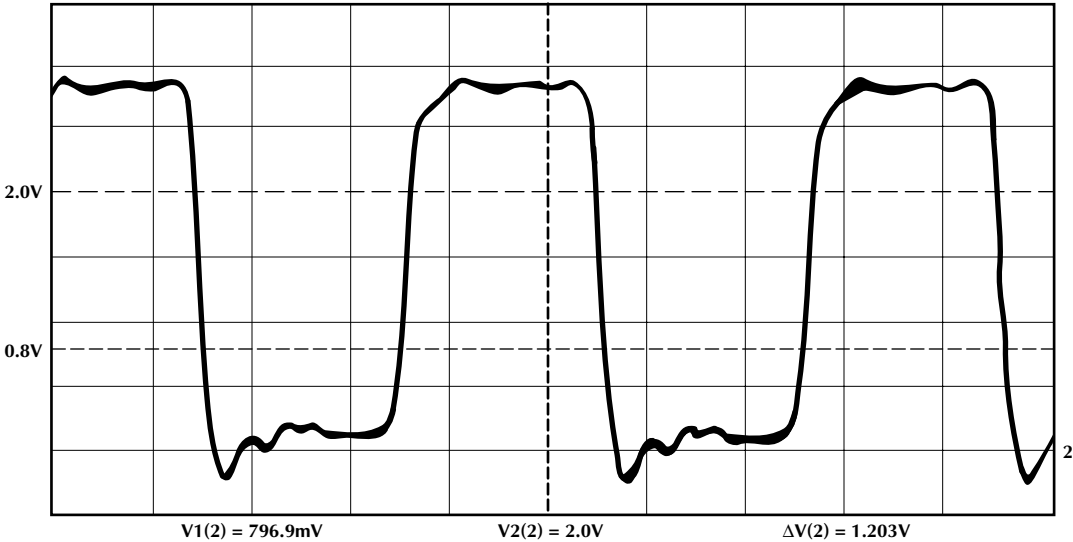

Figure 2. Application Diagram Showing Typical SCSI Bus Configuration with the ML6599

TRANSIENT RESPONSE (ACTUAL)

(Approximately 110Ω, 10 feet long, ribbon cable stock)



PHYSICAL DIMENSIONS inches (millimeters)

Package: T20
20-Pin TSSOP

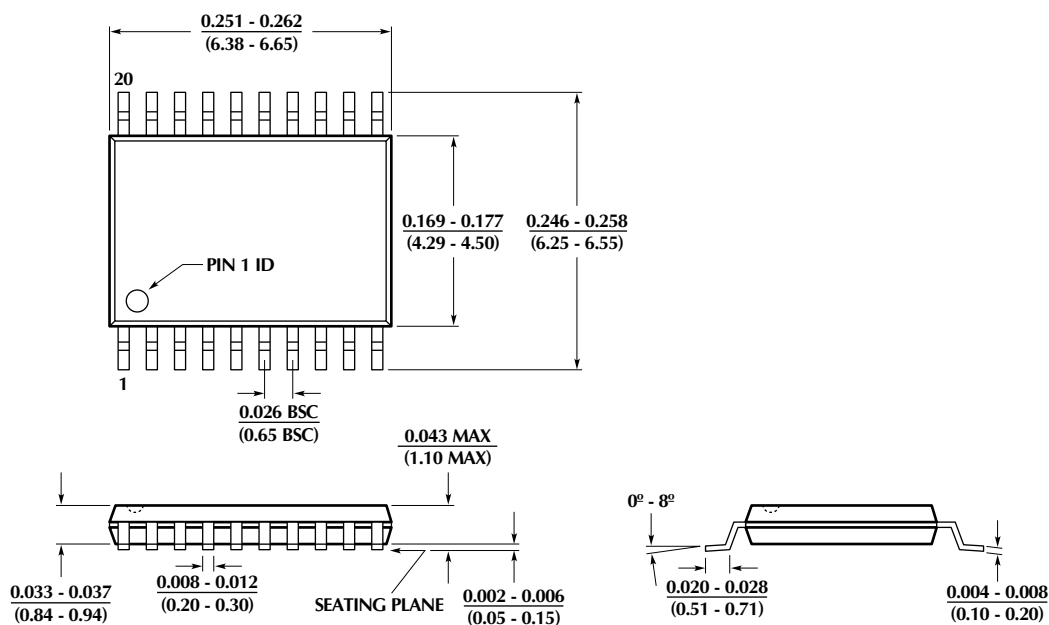

Package: S16W
16-Pin Wide SOIC

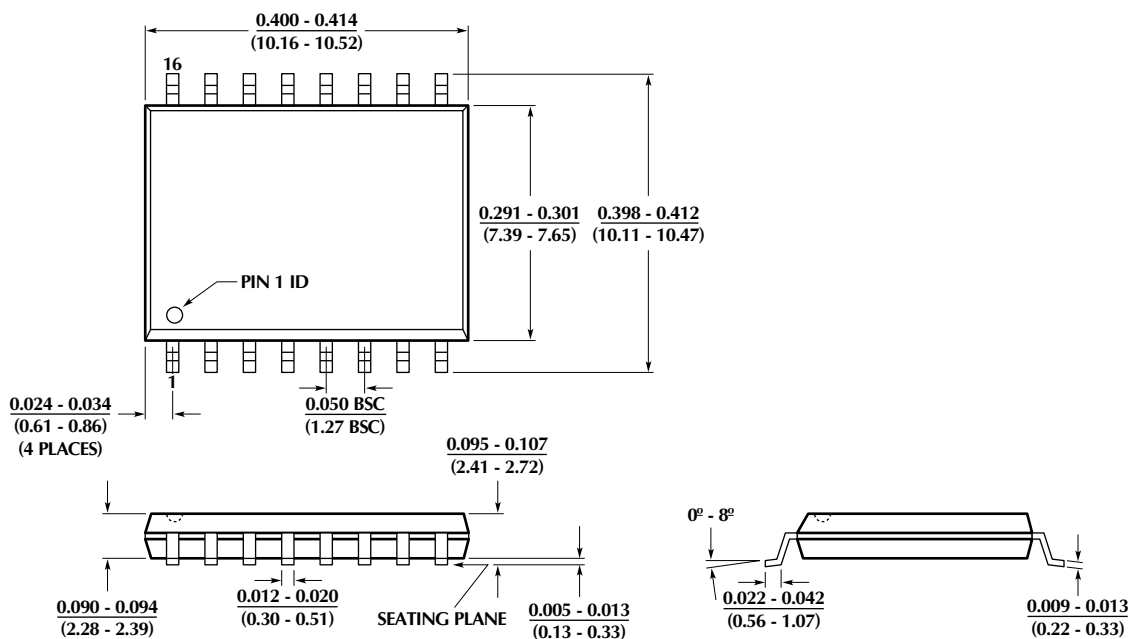

ORDERING INFORMATION

PART NUMBER	TEMPERATURE RANGE	PACKAGE
ML6599CS	0°C to 70°C	16-pin SOIC (S16W) (Obsolete)
ML6599CT	0°C to 70°C	20-pin TSSOP (T20)

© Micro Linear 1997  **Micro Linear** is a registered trademark of Micro Linear Corporation
Products described herein may be covered by one or more of the following patents: 4,897,611; 4,964,026; 5,027,116; 5,281,862; 5,283,483; 5,418,502; 5,508,570; 5,510,727; 5,523,940; 5,546,017;
5,559,470; 5,565,761; 5,594,376. Other patents are pending.

Micro Linear reserves the right to make changes to any product herein to improve reliability, function or design. Micro Linear does not assume any liability arising out of the application or use of any product described herein, neither does it convey any license under its patent right nor the rights of others. The circuits contained in this data sheet are offered as possible applications only. Micro Linear makes no warranties or representations as to whether the illustrated circuits infringe any intellectual property rights of others, and will accept no responsibility or liability for use of any application herein. The customer is urged to consult with appropriate legal counsel before deciding on a particular application.

2092 Concourse Drive
San Jose, CA 95131
Tel: 408/433-5200
Fax: 408/432-0295