

PRELIMINARY
 Notice: This is not a final specification.
 Some parametric limits are subject to
 change.

MITSUBISHI MICROCOMPUTERS 4512 Group

SINGLE-CHIP 4-BIT CMOS MICROCOMPUTER

DESCRIPTION

The 4512 Group is a 4-bit single-chip microcomputer designed with CMOS technology. Its CPU is that of the 4500 series using a simple, high-speed instruction set. The computer is equipped with serial I/O, four 8-bit timers (each timer has a reload register), and 10-bit A-D converter.

The various microcomputers in the 4512 Group include variations of the built-in memory size as shown in the table below.

FEATURES

- Minimum instruction execution time 0.75 μ s
 (at 4.0 MHz oscillation frequency, in high-speed mode, VDD = 4.0 V to 5.5 V)
- Supply voltage 4.0 V to 5.5 V (at 4.2 MHz oscillation frequency)

- Timers
 - Timer 1 8-bit timer with a reload register
 - Timer 2 8-bit timer with a reload register
 - Timer 3 8-bit timer with a reload register
 - Timer 4 8-bit timer with a reload register
- Interrupt 8 sources
- Serial I/O 8 bit-wide
- A-D converter 10-bit successive comparison method
- Watchdog timer 16 bits
- Clock generating circuit (ceramic resonator)
- LED drive directly enabled (port D)

APPLICATION

Electrical household appliance, consumer electronic products, office automation equipment, etc.

Product	ROM (PROM) size (X 10 bits)	RAM size (X 4 bits)	Package	ROM type
M34512M2-XXXXFP	2048 words	128 words	32P6B-A	Mask ROM
M34512M4-XXXXFP	4096 words	256 words	32P6B-A	Mask ROM

PIN CONFIGURATION (TOP VIEW)

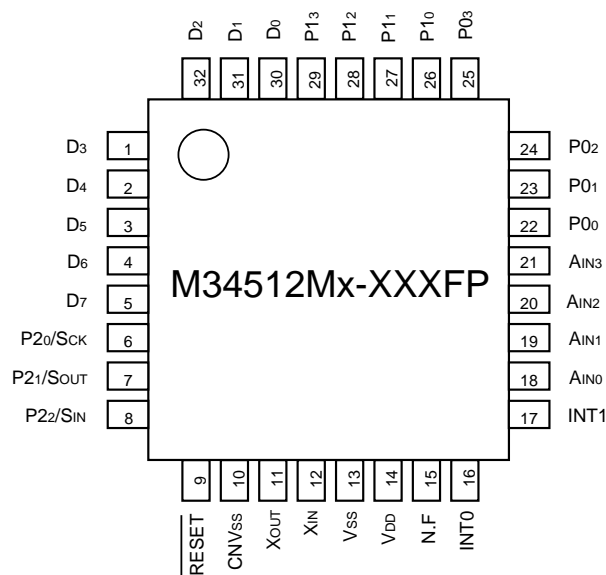

Outline 32P6B-A

N.F: No Function
 However, connect to Vss as an
 unused pin.

PRELIMINARY
 Notice: This is not a final specification.
 Some parametric limits are subject to change.

BLOCK DIAGRAM

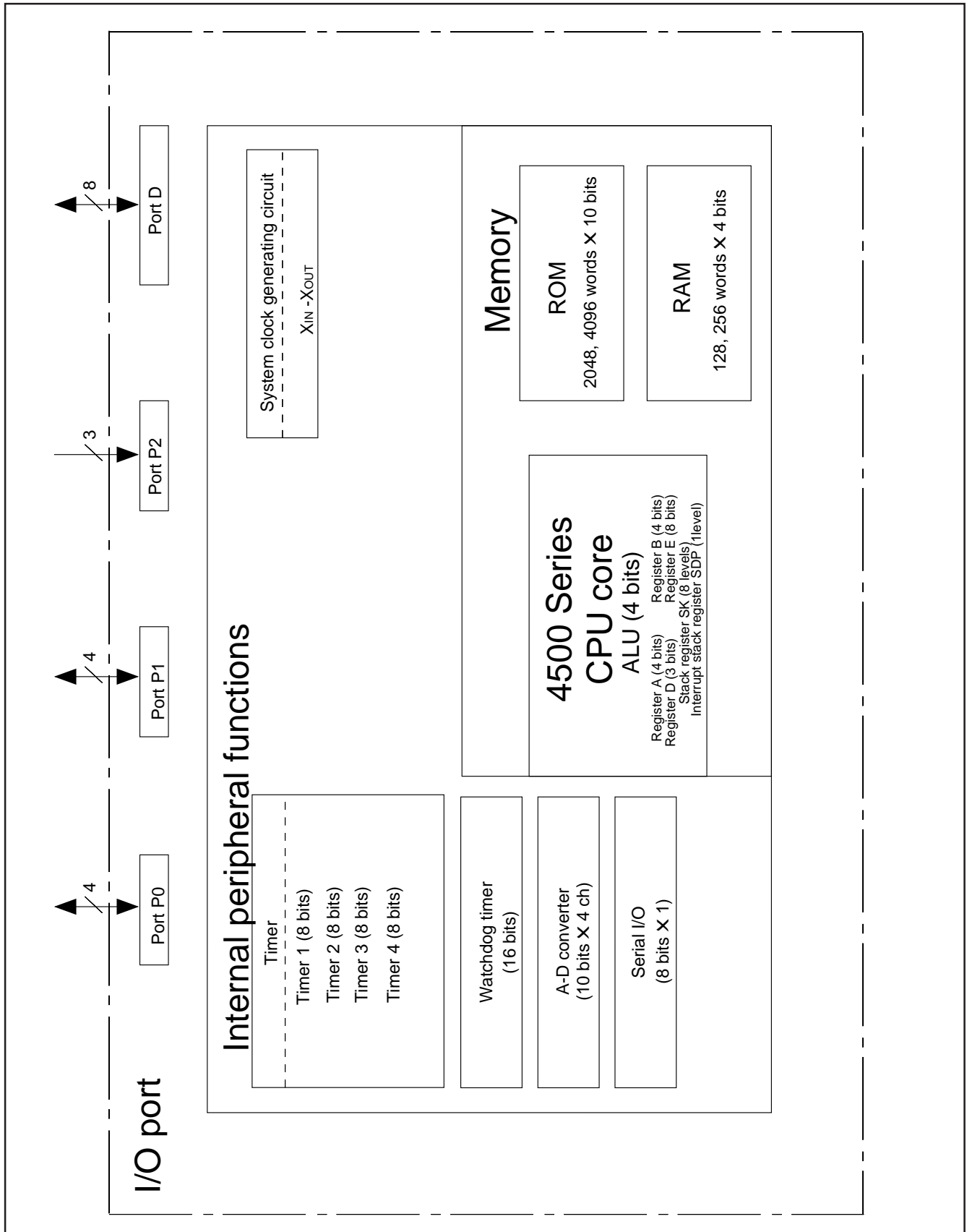

PRELIMINARY
 Notice: This is not a final specification.
 Some parametric limits are subject to
 change.

PERFORMANCE OVERVIEW

Parameter		Function	
Number of basic instructions		117	
Minimum instruction execution time		0.75 μ s (at 4.0 MHz oscillation frequency, in high-speed mode)	
Memory sizes	ROM	M34512M2	2048 words X 10 bits
		M34512M4	4096 words X 10 bits
	RAM	M34512M2	128 words X 4 bits
		M34512M4	256 words X 4 bits
Input/Output ports	D0–D7	I/O	Eight independent I/O ports. Input is examined by skip decision.
	P00–P03	I/O	4-bit I/O port; each pin is equipped with a pull-up function and a key-on wakeup function. Both functions can be switched by software.
	P10–P13	I/O	4-bit I/O port; each pin is equipped with a pull-up function and a key-on wakeup function. Both functions can be switched by software.
	P20–P22	Input	3-bit input port; ports P20, P21 and P22 are also used as SCK, SOUT and SIN, respectively.
	INT0	Input	1-bit input; INT0 pin is equipped with a key-on wakeup function.
	INT1	Input	1-bit input; INT1 pin is equipped with a key-on wakeup function.
Timers	Timer 1		8-bit programmable timer with a reload register.
	Timer 2		8-bit programmable timer with a reload register.
	Timer 3		8-bit programmable timer with a reload register.
	Timer 4		8-bit programmable timer with a reload register.
A-D converter		10-bit wide, This is equipped with an 8-bit comparator function.	
Serial I/O		8-bit X 1	
Interrupt	Sources	8 (two for external, four for timer, one for A-D, and one for serial I/O)	
	Nesting	1 level	
Subroutine nesting		8 levels	
Device structure		CMOS silicon gate	
Package		32-pin plastic molded LQFP(32P6B-A)	
Operating temperature range		–20 °C to 85 °C	
Supply voltage		4.0 V to 5.5 V	
Power dissipation (typical value)	Active mode	3.0 mA (at V _{DD} = 5.0 V, 4.0 MHz oscillation frequency, in high-speed mode, output transistors in the cut-off state)	
	RAM back-up mode	0.1 μ A (at room temperature, V _{DD} = 5 V, output transistors in the cut-off state)	

PRELIMINARY
 Notice: This is not a final specification.
 Some parametric limits are subject to
 change.

PIN DESCRIPTION

Pin	Name	Input/Output	Function
VDD	Power supply	—	Connected to a plus power supply.
VSS	Ground	—	Connected to a 0 V power supply.
N.F	No Function	—	This pin has no function, and connect to Vss as an unused pin.
CNVss	CNVss	—	Connect CNVss to Vss and apply "L" (0V) to CNVss certainly.
RESET	Reset input	I/O	An N-channel open-drain I/O pin for a system reset. When the watchdog timer causes the system to be reset, the RESET pin outputs "L" level.
XIN	System clock input	Input	I/O pins of the system clock generating circuit. XIN and XOUT can be connected to ceramic resonator. A feedback resistor is built-in between them.
XOUT	System clock output	Output	
D0–D7	I/O port D	I/O	Each pin of port D has an independent 1-bit wide I/O function. Each pin has an output latch. For input use, set the latch of the specified bit to "1." Input is examined by skip decision. The output structure is N-channel open-drain.
P00–P03	I/O port P0	I/O	Each of ports P0 and P1 serves as a 4-bit I/O port, and it can be used as inputs when the output latch is set to "1." The output structure is N-channel open-drain.
P10–P13	I/O port P1		Every pin of the ports has a key-on wakeup function and a pull-up function. Both functions can be switched by software.
P20–P22	Input port P2	Input	3-bit input port. Ports P20, P21 and P22 are also used as SCK, SOUT and SIN, respectively.
AIN0–AIN3	Analog input	Input	Analog input pins for A-D converter.
INT0, INT1	Interrupt input	Input	INT0, INT1 pins accept external interrupts. They also accept the input signal to return the system from the RAM back-up state.
SIN	Serial data input	Input	SIN pin is used to input serial data signals by software. SIN pin is also used as port P22.
SOUT	Serial data output	Output	SOUT pin is used to output serial data signals by software. SOUT pin is also used as port P21.
SCK	Serial I/O clock input/output	I/O	SCK pin is used to input and output synchronous clock signals for serial data transfer by software. SCK pin is also used as port P20.

PRELIMINARY
 Notice: This is not a final specification.
 Some parametric limits are subject to change.

MULTIFUNCTION

Pin	Multifunction	Pin	Multifunction
P20	SCK	SCK	P20
P21	SOUT	SOUT	P21
P22	SIN	SIN	P22

Notes 1: Pins except above have just single function.
 2: The input of P20–P22 can be used even when SCK, SOUT, SIN are selected.

DEFINITION OF CLOCK AND CYCLE

- System clock
 The system clock is the basic clock for controlling this product. The system clock is selected by the bit 3 of the clock control register MR.

Table Selection of system clock

Register MR MR3	System clock
0	f(XIN)
1	f(XIN)/2

Note: f(XIN)/2 is selected after system is released from reset.

- Instruction clock
 The instruction clock is a signal derived by dividing the system clock by 3. The one instruction clock cycle generates the one machine cycle.
- Machine cycle
 The machine cycle is the standard cycle required to execute the instruction.

CONNECTIONS OF UNUSED PINS

Pin	Connection
XOUT	Open (when using an external clock).
N.F	Connect to Vss.
D0–D7	Connect to Vss, or set the output latch to “0” and open.
P20/SCK P21/SOUT P22/SIN	Connect to Vss.
INT0 INT1	Connect to Vss.
AIN0–AIN3	Connect to Vss.
P00–P03	Open or connect to Vss (Note)
P10–P13	Open or connect to Vss (Note)

Note: When the P00–P03 and P10–P13 are connected to Vss, turn off their pull-up transistors (register PU0i=“0”) and also invalidate the key-on wakeup functions (register K0i=“0”) by software. When these pins are connected to Vss while the key-on wakeup functions are left valid, the system fails to return from RAM back-up state. When these pins are open, turn on their pull-up transistors (register PU0i=“1”) by software, or set the output latch to “0.”

Be sure to select the key-on wakeup functions and the pull-up functions with every two pins. If only one of the two pins for the key-on wakeup function is used, turn on their pull-up transistors by software and also disconnect the other pin. (i = 0, 1, 2, or 3.)

- (Note when the output latch is set to “0” and pins are open)
- After system is released from reset, port is in a high-impedance state until it is set the output latch to “0” by software. Accordingly, the voltage level of pins is undefined and the excess of the supply current may occur while the port is in a high-impedance state.
 - To set the output latch periodically by software is recommended because value of output latch may change by noise or a program run away (caused by noise).

- (Note when connecting to Vss and VDD)
- Connect the unused pins to Vss and VDD using the thickest wire at the shortest distance against noise.

PORT FUNCTION

Port	Pin	Input Output	Output structure	I/O unit	Control instructions	Control registers	Remark
Port D	D0–D7	I/O (8)	N-channel open-drain	1	SD, RD SZD CLD		
Port P0	P00–P03	I/O (4)	N-channel open-drain	4	OP0A IAP0	PU0, K0	Built-in programmable pull-up functions Key-on wakeup functions (programmable)
Port P1	P10–P13	I/O (4)	N-channel open-drain	4	OP1A IAP1	PU0, K0	Built-in programmable pull-up functions Key-on wakeup functions (programmable)
Port P2	P20/SCK P21/SOUT P22/SIN	Input (3)		3	IAP2	J1	

PORT BLOCK DIAGRAMS

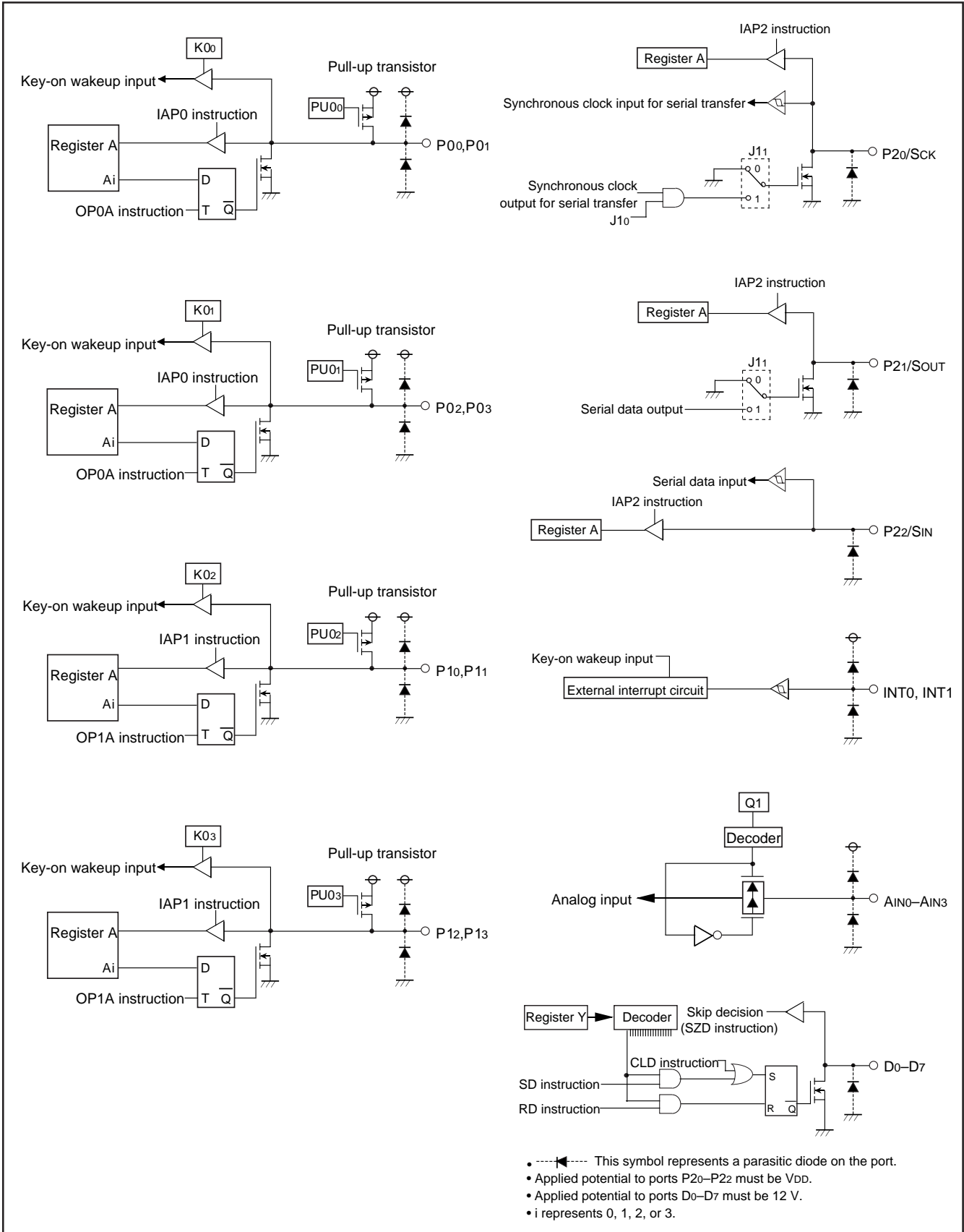

PRELIMINARY
 Notice: This is not a final specification.
 Some parametric limits are subject to
 change.

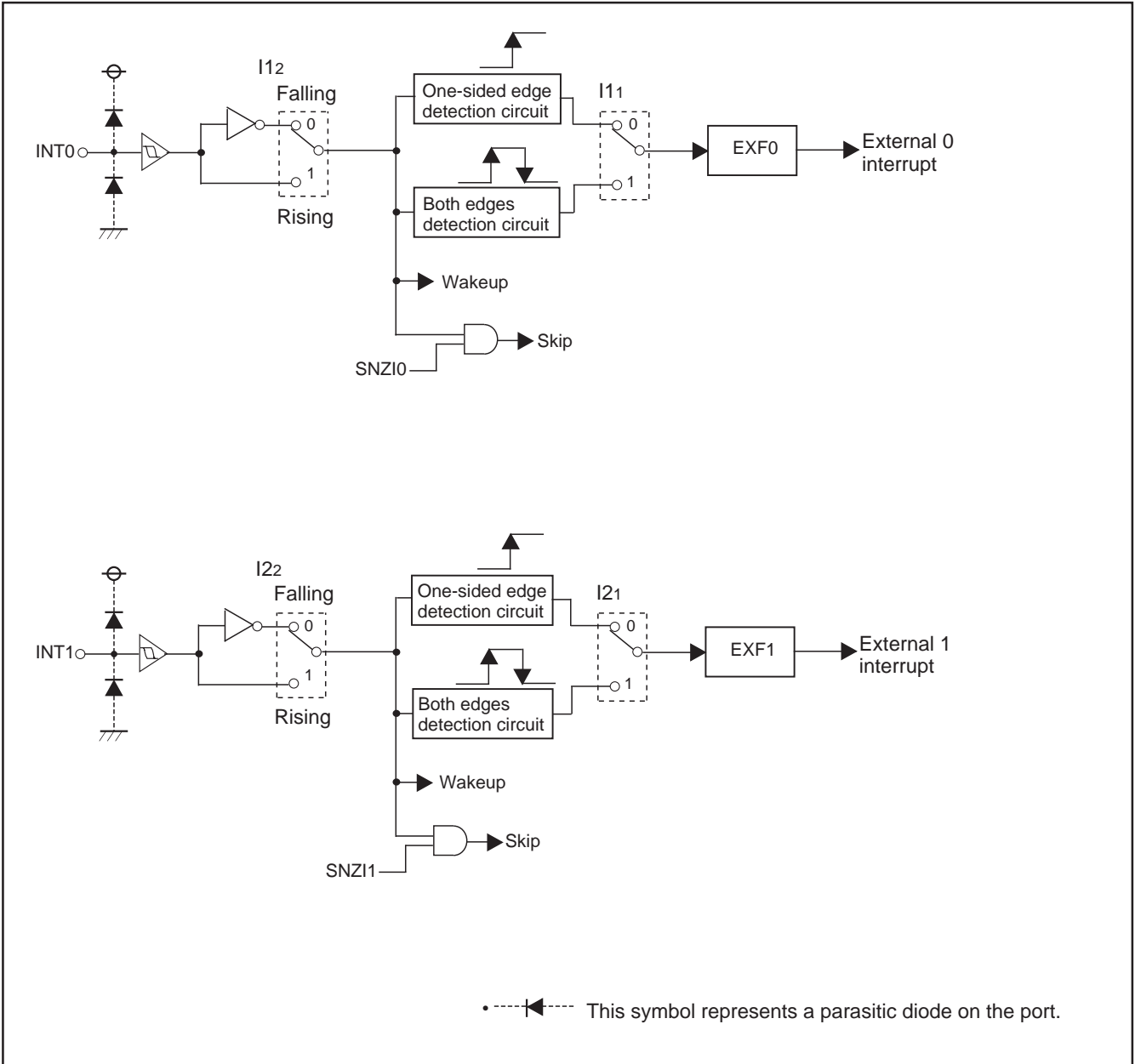

External interrupt circuit structure

PRELIMINARY
 Notice: This is not a final specification.
 Some parametric limits are subject to
 change.

**FUNCTION BLOCK OPERATIONS
 CPU**

(1) Arithmetic logic unit (ALU)

The arithmetic logic unit ALU performs 4-bit arithmetic such as 4-bit data addition, comparison, AND operation, OR operation, and bit manipulation.

(2) Register A and carry flag

Register A is a 4-bit register used for arithmetic, transfer, exchange, and I/O operation.

Carry flag CY is a 1-bit flag that is set to "1" when there is a carry with the AMC instruction (Figure 1).

It is unchanged with both A n instruction and AM instruction. The value of A0 is stored in carry flag CY with the RAR instruction (Figure 2).

Carry flag CY can be set to "1" with the SC instruction and cleared to "0" with the RC instruction.

(3) Registers B and E

Register B is a 4-bit register used for temporary storage of 4-bit data, and for 8-bit data transfer together with register A.

Register E is an 8-bit register. It can be used for 8-bit data transfer with register B used as the high-order 4 bits and register A as the low-order 4 bits (Figure 3).

(4) Register D

Register D is a 3-bit register.

It is used to store a 7-bit ROM address together with register A and is used as a pointer within the specified page when the TABP p, BLA p, or BMLA p instruction is executed (Figure 4).

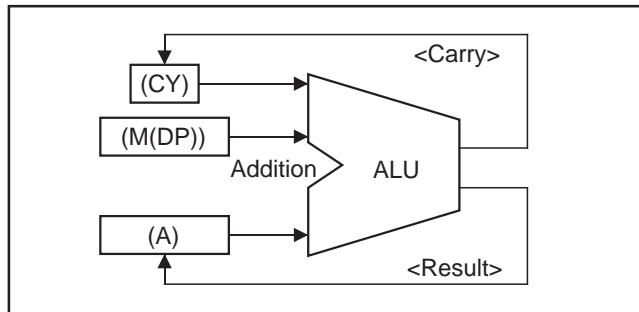

Fig. 1 AMC instruction execution example

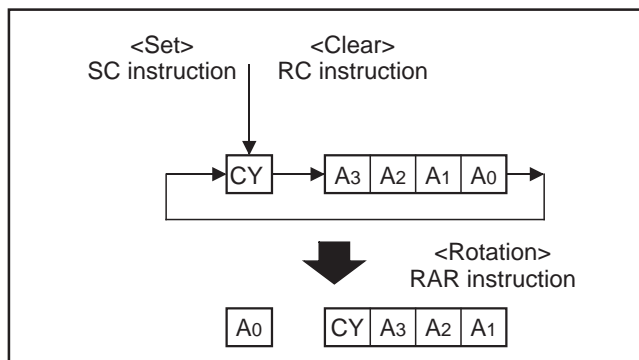

Fig. 2 RAR instruction execution example

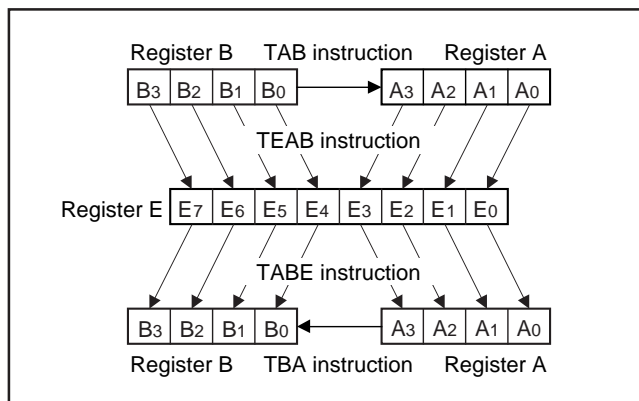

Fig. 3 Registers A, B and register E

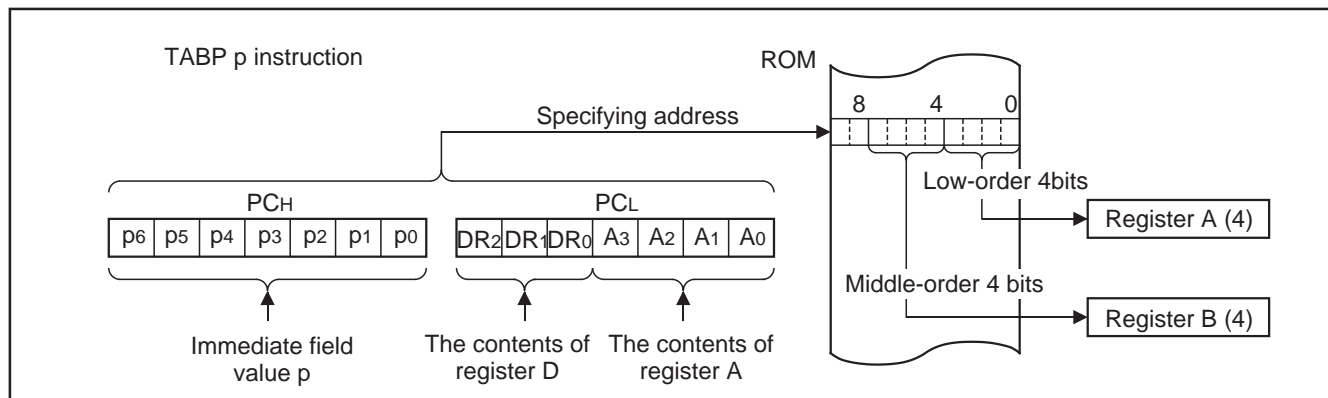

Fig. 4 TABP p instruction execution example

PRELIMINARY
 Notice: This is not a final specification.
 Some parametric limits are subject to change.

(5) Stack registers (SKs) and stack pointer (SP)

Stack registers (SKs) are used to temporarily store the contents of program counter (PC) just before branching until returning to the original routine when;

- branching to an interrupt service routine (referred to as an interrupt service routine),
- performing a subroutine call, or
- executing the table reference instruction (TABP).

Stack registers (SKs) are eight identical registers, so that subroutines can be nested up to 8 levels. However, one of stack registers is used respectively when using an interrupt service routine and when executing a table reference instruction. Accordingly, be careful not to over the stack when performing these operations together. The contents of registers SKs are destroyed when 8 levels are exceeded.

The register SK nesting level is pointed automatically by 3-bit stack pointer (SP). The contents of the stack pointer (SP) can be transferred to register A with the TASP instruction.

Figure 5 shows the stack registers (SKs) structure.

Figure 6 shows the example of operation at subroutine call.

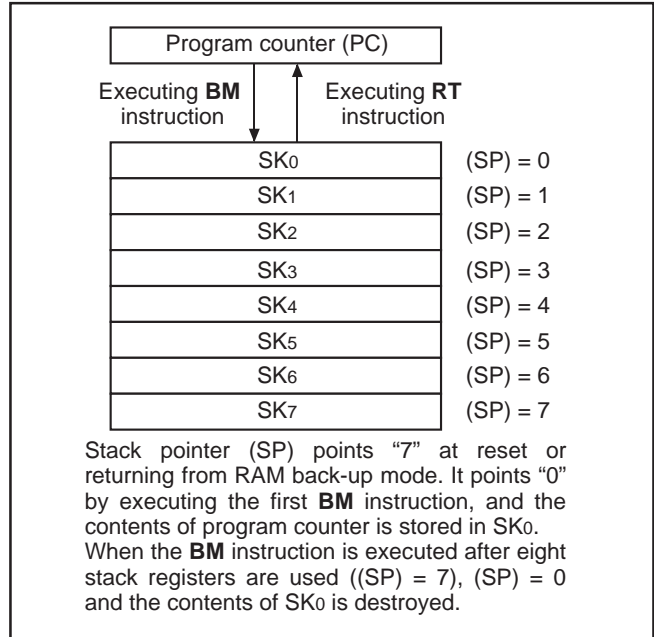

Fig. 5 Stack registers (SKs) structure

(6) Interrupt stack register (SDP)

Interrupt stack register (SDP) is a 1-stage register. When an interrupt occurs, this register (SDP) is used to temporarily store the contents of data pointer, carry flag, skip flag, register A, and register B just before an interrupt until returning to the original routine.

Unlike the stack registers (SKs), this register (SDP) is not used when executing the subroutine call instruction and the table reference instruction.

(7) Skip flag

Skip flag controls skip decision for the conditional skip instructions and continuous described skip instructions. When an interrupt occurs, the contents of skip flag is stored automatically in the interrupt stack register (SDP) and the skip condition is retained.

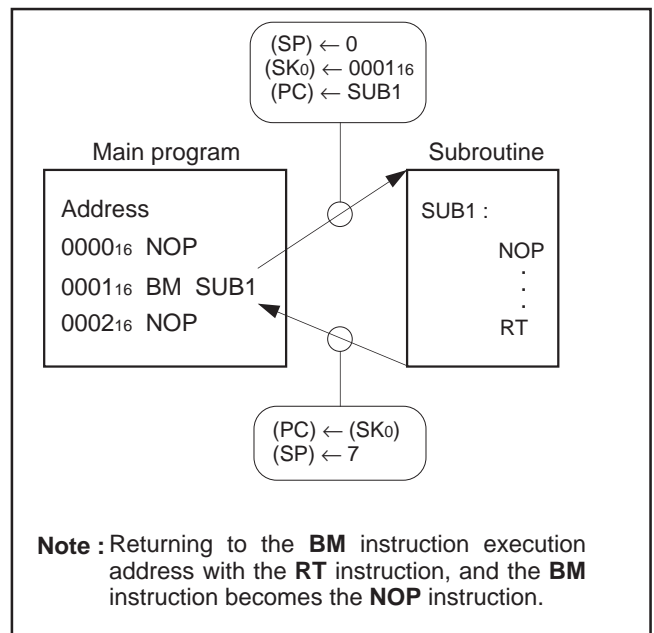

Fig. 6 Example of operation at subroutine call

PRELIMINARY
 Notice: This is not a final specification.
 Some parametric limits are subject to change.

(8) Program counter (PC)

Program counter (PC) is used to specify a ROM address (page and address). It determines a sequence in which instructions stored in ROM are read. It is a binary counter that increments the number of instruction bytes each time an instruction is executed. However, the value changes to a specified address when branch instructions, subroutine call instructions, return instructions, or the table reference instruction (TABP p) is executed.

Program counter consists of PCH (most significant bit to bit 7) which specifies to a ROM page and PCL (bits 6 to 0) which specifies an address within a page. After it reaches the last address (address 127) of a page, it specifies address 0 of the next page (Figure 7).

Make sure that the PCH does not specify after the last page of the built-in ROM.

(9) Data pointer (DP)

Data pointer (DP) is used to specify a RAM address and consists of registers Z, X, and Y. Register Z specifies a RAM file group, register X specifies a file, and register Y specifies a RAM digit (Figure 8).

Register Y is also used to specify the port D bit position. When using port D, set the port D bit position to register Y certainly and execute the SD, RD, or SZD instruction (Figure 9).

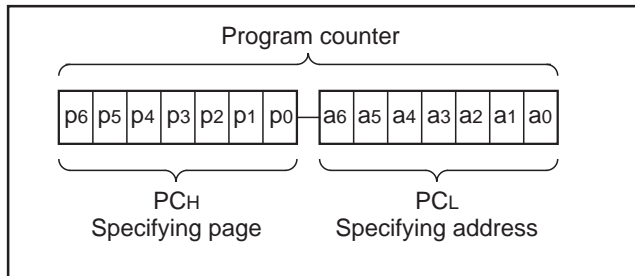

Fig. 7 Program counter (PC) structure

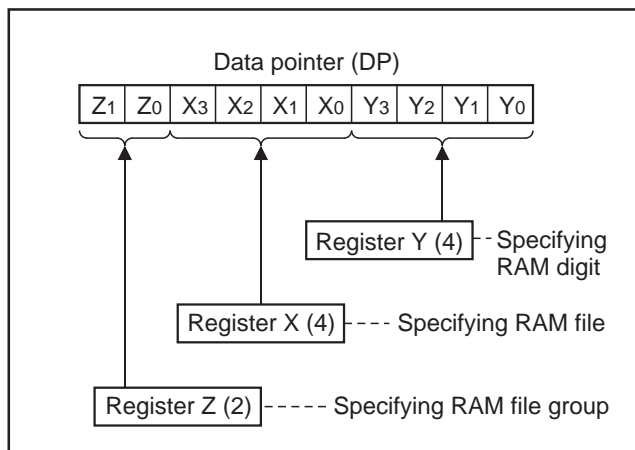

Fig. 8 Data pointer (DP) structure

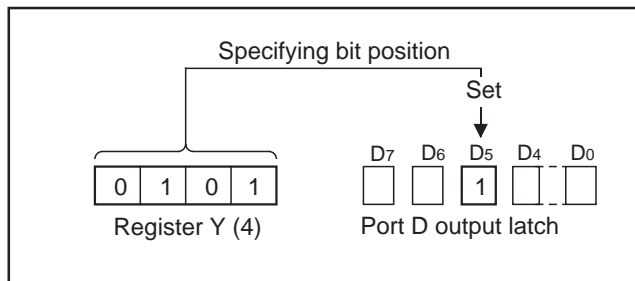

Fig. 9 SD instruction execution example

PRELIMINARY
 Notice: This is not a final specification.
 Some parametric limits are subject to change.

PROGRAM MEMOY (ROM)

The program memory is a mask ROM. 1 word of ROM is composed of 10 bits. ROM is separated every 128 words by the unit of page (addresses 0 to 127). Table 1 shows the ROM size and pages. Figure 10 shows the ROM map of M34512M4.

Table 1 ROM size and pages

Product	ROM size (X 10 bits)	Pages
M34512M2	2048 words	16 (0 to 15)
M34512M4	4096 words	32 (0 to 31)

A part of page 1 (addresses 0080₁₆ to 00FF₁₆) is reserved for interrupt addresses (Figure 11). When an interrupt occurs, the address (interrupt address) corresponding to each interrupt is set in the program counter, and the instruction at the interrupt address is executed. When using an interrupt service routine, write the instruction generating the branch to that routine at an interrupt address.

Page 2 (addresses 0100₁₆ to 017F₁₆) is the special page for subroutine calls. Subroutines written in this page can be called from any page with the 1-word instruction (BM). Subroutines extending from page 2 to another page can also be called with the BM instruction when it starts on page 2.

ROM pattern (bits 7 to 0) of all addresses can be used as data areas with the TABP p instruction.

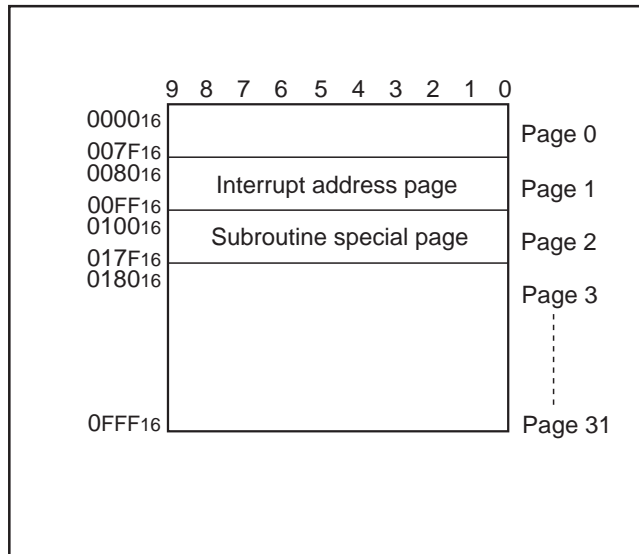

Fig. 10 ROM map of M34512M4

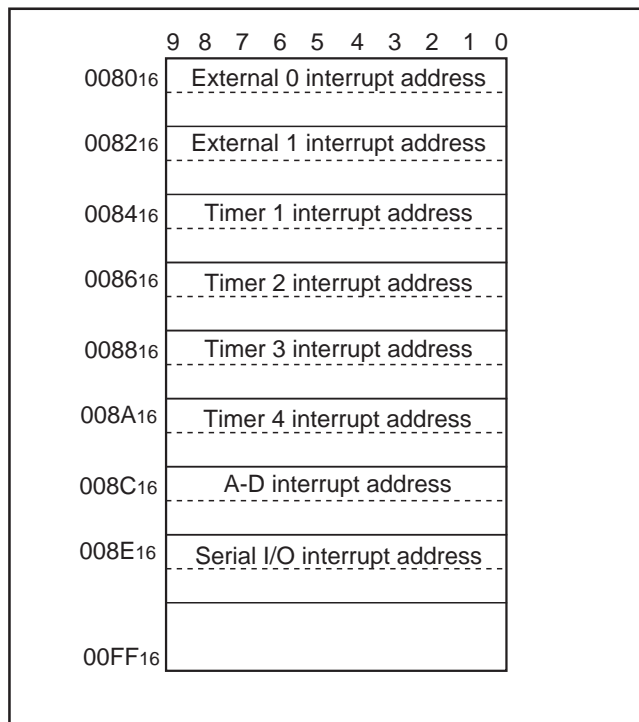

Fig. 11 Page 1 (addresses 0080₁₆ to 00FF₁₆) structure

PRELIMINARY
 Notice: This is not a final specification.
 Some parametric limits are subject to change.

DATA MEMORY (RAM)

1 word of RAM is composed of 4 bits, but 1-bit manipulation (with the SB j, RB j, and SZB j instructions) is enabled for the entire memory area. A RAM address is specified by a data pointer. The data pointer consists of registers Z, X, and Y. Set a value to the data pointer certainly when executing an instruction to access RAM.

Table 2 shows the RAM size. Figure 12 shows the RAM map.

Table 2 RAM size

Product	RAM size
M34512M2	128 words X 4 bits (512 bits)
M34512M4	256 words X 4 bits (1024 bits)

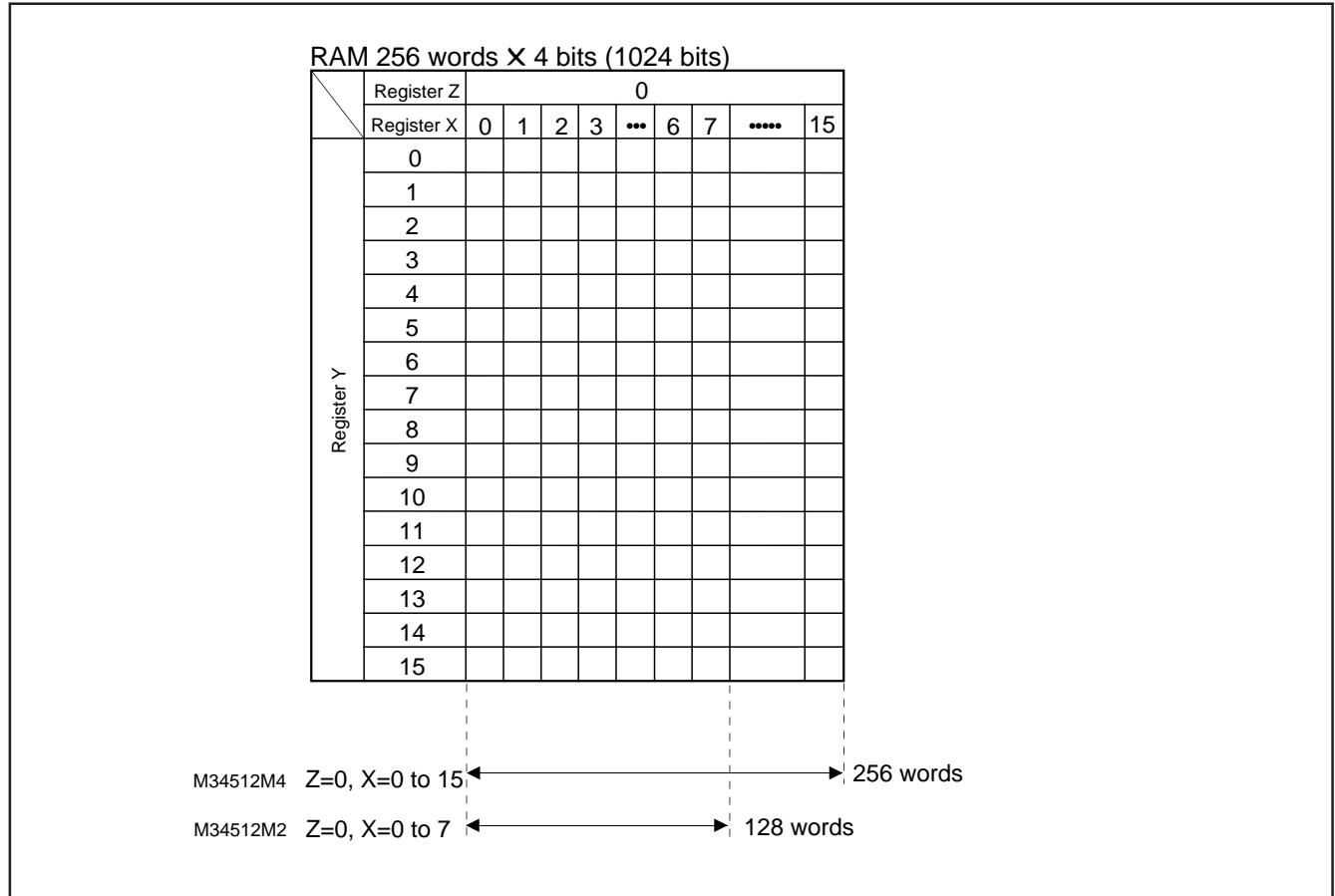

Fig. 12 RAM map

PRELIMINARY
 Notice: This is not a final specification.
 Some parametric limits are subject to
 change.

INTERRUPT FUNCTION

The interrupt type is a vectored interrupt branching to an individual address (interrupt address) according to each interrupt source. An interrupt occurs when the following 3 conditions are satisfied.

- An interrupt activated condition is satisfied (request flag = "1")
- Interrupt enable bit is enabled ("1")
- Interrupt enable flag is enabled (INTE = "1")

Table 3 shows interrupt sources. (Refer to each interrupt request flag for details of activated conditions.)

(1) Interrupt enable flag (INTE)

The interrupt enable flag (INTE) controls whether the every interrupt enable/disable. Interrupts are enabled when INTE flag is set to "1" with the EI instruction and disabled when INTE flag is cleared to "0" with the DI instruction. When any interrupt occurs, the INTE flag is automatically cleared to "0," so that other interrupts are disabled until the EI instruction is executed.

(2) Interrupt enable bit

Use an interrupt enable bit of interrupt control registers V1 and V2 to select the corresponding interrupt or skip instruction.

Table 4 shows the interrupt request flag, interrupt enable bit and skip instruction.

Table 5 shows the interrupt enable bit function.

(3) Interrupt request flag

When the activated condition for each interrupt is satisfied, the corresponding interrupt request flag is set to "1." Each interrupt request flag is cleared to "0" when either;

- an interrupt occurs, or
- the next instruction is skipped with a skip instruction.

Each interrupt request flag is set when the activated condition is satisfied even if the interrupt is disabled by the INTE flag or its interrupt enable bit. Once set, the interrupt request flag retains set until a clear condition is satisfied.

Accordingly, an interrupt occurs when the interrupt disable state is released while the interrupt request flag is set.

If more than one interrupt request flag is set when the interrupt disable state is released, the interrupt priority level is as follows shown in Table 3.

Table 3 Interrupt sources

Priority level	Interrupt name	Activated condition	Interrupt address
1	External 0 interrupt	Level change of INT0 pin	Address 0 in page 1
2	External 1 interrupt	Level change of INT1 pin	Address 2 in page 1
3	Timer 1 interrupt	Timer 1 underflow	Address 4 in page 1
4	Timer 2 interrupt	Timer 2 underflow	Address 6 in page 1
5	Timer 3 interrupt	Timer 3 underflow	Address 8 in page 1
6	Timer 4 interrupt	Timer 4 underflow	Address A in page 1
7	A-D interrupt	Completion of A-D conversion	Address C in page 1
8	Serial I/O interrupt	Completion of serial I/O transfer	Address E in page 1

Table 4 Interrupt request flag, interrupt enable bit and skip instruction

Interrupt name	Request flag	Skip instruction	Enable bit
External 0 interrupt	EXF0	SNZ0	V10
External 1 interrupt	EXF1	SNZ1	V11
Timer 1 interrupt	T1F	SNZT1	V12
Timer 2 interrupt	T2F	SNZT2	V13
Timer 3 interrupt	T3F	SNZT3	V20
Timer 4 interrupt	T4F	SNZT4	V21
A-D interrupt	ADF	SNZAD	V22
Serial I/O interrupt	SIOF	SNZSI	V23

Table 5 Interrupt enable bit function

Interrupt enable bit	Occurrence of interrupt	Skip instruction
1	Enabled	Invalid
0	Disabled	Valid

PRELIMINARY
 Notice: This is not a final specification.
 Some parametric limits are subject to change.

(4) Internal state during an interrupt

The internal state of the microcomputer during an interrupt is as follows (Figure 14).

- Program counter (PC)
 An interrupt address is set in program counter. The address to be executed when returning to the main routine is automatically stored in the stack register (SK).
- Stack register (SK)
 The address of main routine to be executed when returning
- Interrupt enable flag (INTE)
 INTE flag is cleared to "0" so that interrupts are disabled.
- Interrupt request flag
 Only the request flag for the current interrupt source is cleared to "0."
- Data pointer, carry flag, skip flag, registers A and B
 The contents of these registers and flags are stored automatically in the interrupt stack register (SDP).

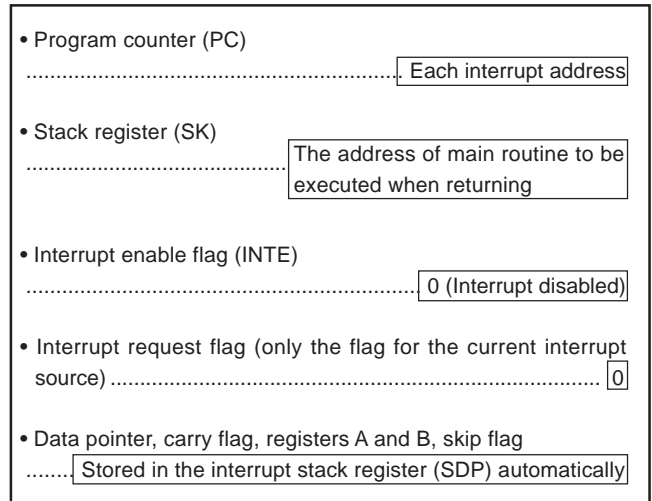

Fig. 14 Internal state when interrupt occurs

(5) Interrupt processing

When an interrupt occurs, a program at an interrupt address is executed after branching a data store sequence to stack register. Write the branch instruction to an interrupt service routine at an interrupt address.

Use the RTI instruction to return from an interrupt service routine. Interrupt enabled by executing the EI instruction is performed after executing 1 instruction (just after the next instruction is executed). Accordingly, when the EI instruction is executed just before the RTI instruction, interrupts are enabled after returning the main routine. (Refer to Figure 13)

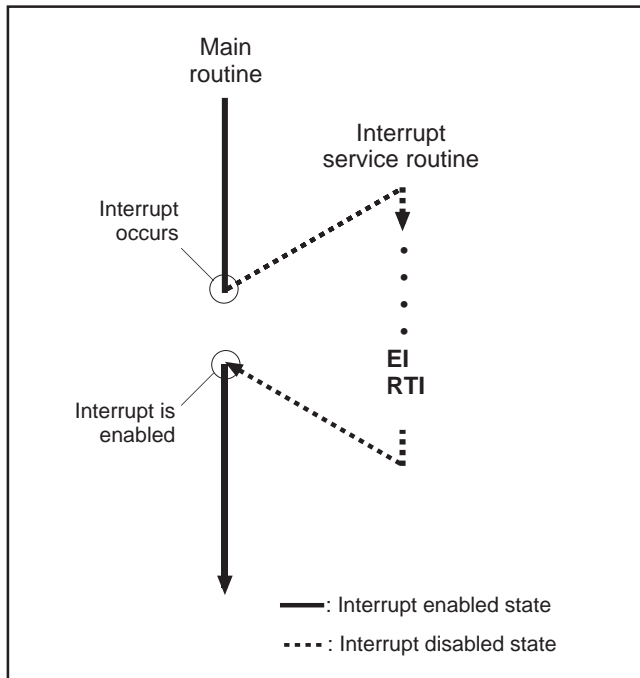

Fig. 13 Program example of interrupt processing

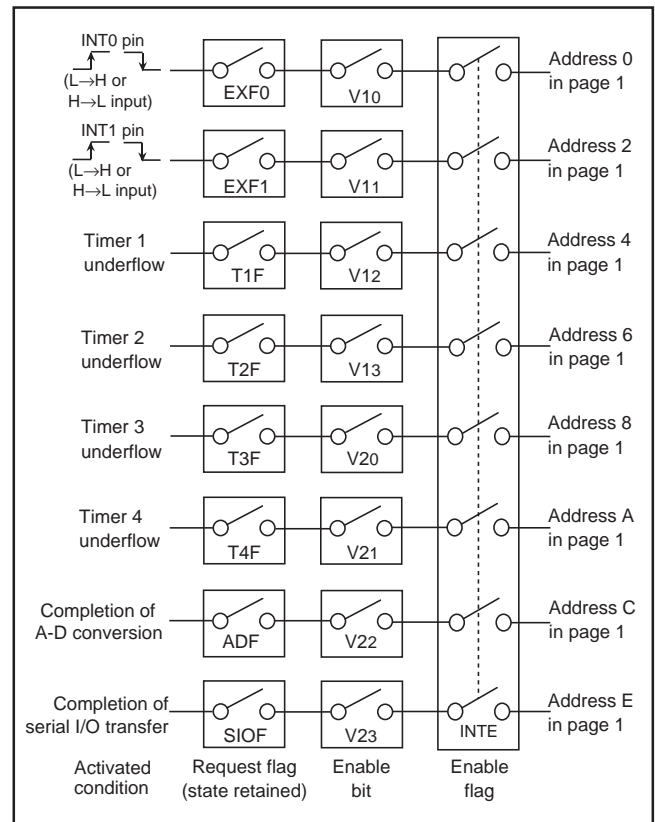

Fig. 15 Interrupt system diagram

PRELIMINARY
 Notice: This is not a final specification.
 Some parametric limits are subject to
 change.

(6) Interrupt control registers

- Interrupt control register V1

Interrupt enable bits of external 0, external 1, timer 1 and timer 2 are assigned to register V1. Set the contents of this register through register A with the TV1A instruction. The TAV1 instruction can be used to transfer the contents of register V1 to register A.

- Interrupt control register V2

Interrupt enable bits of timer 3, timer 4, A-D and serial I/O are assigned to register V2. Set the contents of this register through register A with the TV2A instruction. The TAV2 instruction can be used to transfer the contents of register V2 to register A.

Table 6 Interrupt control registers

Interrupt control register V1		at reset : 0000 ₂		at RAM back-up : 0000 ₂		R/W
V13	Timer 2 interrupt enable bit	0	Interrupt disabled (SNZT2 instruction is valid)			
		1	Interrupt enabled (SNZT2 instruction is invalid)			
V12	Timer 1 interrupt enable bit	0	Interrupt disabled (SNZT1 instruction is valid)			
		1	Interrupt enabled (SNZT1 instruction is invalid)			
V11	External 1 interrupt enable bit	0	Interrupt disabled (SNZ1 instruction is valid)			
		1	Interrupt enabled (SNZ1 instruction is invalid)			
V10	External 0 interrupt enable bit	0	Interrupt disabled (SNZ0 instruction is valid)			
		1	Interrupt enabled (SNZ0 instruction is invalid)			
Interrupt control register V2		at reset : 0000 ₂		at RAM back-up : 0000 ₂		R/W
V23	Serial I/O interrupt enable bit	0	Interrupt disabled (SNZSI instruction is valid)			
		1	Interrupt enabled (SNZSI instruction is invalid)			
V22	A-D interrupt enable bit	0	Interrupt disabled (SNZAD instruction is valid)			
		1	Interrupt enabled (SNZAD instruction is invalid)			
V21	Timer 4 interrupt enable bit	0	Interrupt disabled (SNZT4 instruction is valid)			
		1	Interrupt enabled (SNZT4 instruction is invalid)			
V20	Timer 3 interrupt enable bit	0	Interrupt disabled (SNZT3 instruction is valid)			
		1	Interrupt enabled (SNZT3 instruction is invalid)			

Note: "R" represents read enabled, and "W" represents write enabled.

(7) Interrupt sequence

Interrupts only occur when the respective INTE flag, interrupt enable bits (V10–V13 and V20–V23), and interrupt request flag are "1." The interrupt actually occurs 2 to 3 machine cycles after the cycle in which all three conditions are satisfied. The interrupt oc-

curs after 3 machine cycles only when the three interrupt conditions are satisfied on execution of other than one-cycle instructions (Refer to Figure 16).

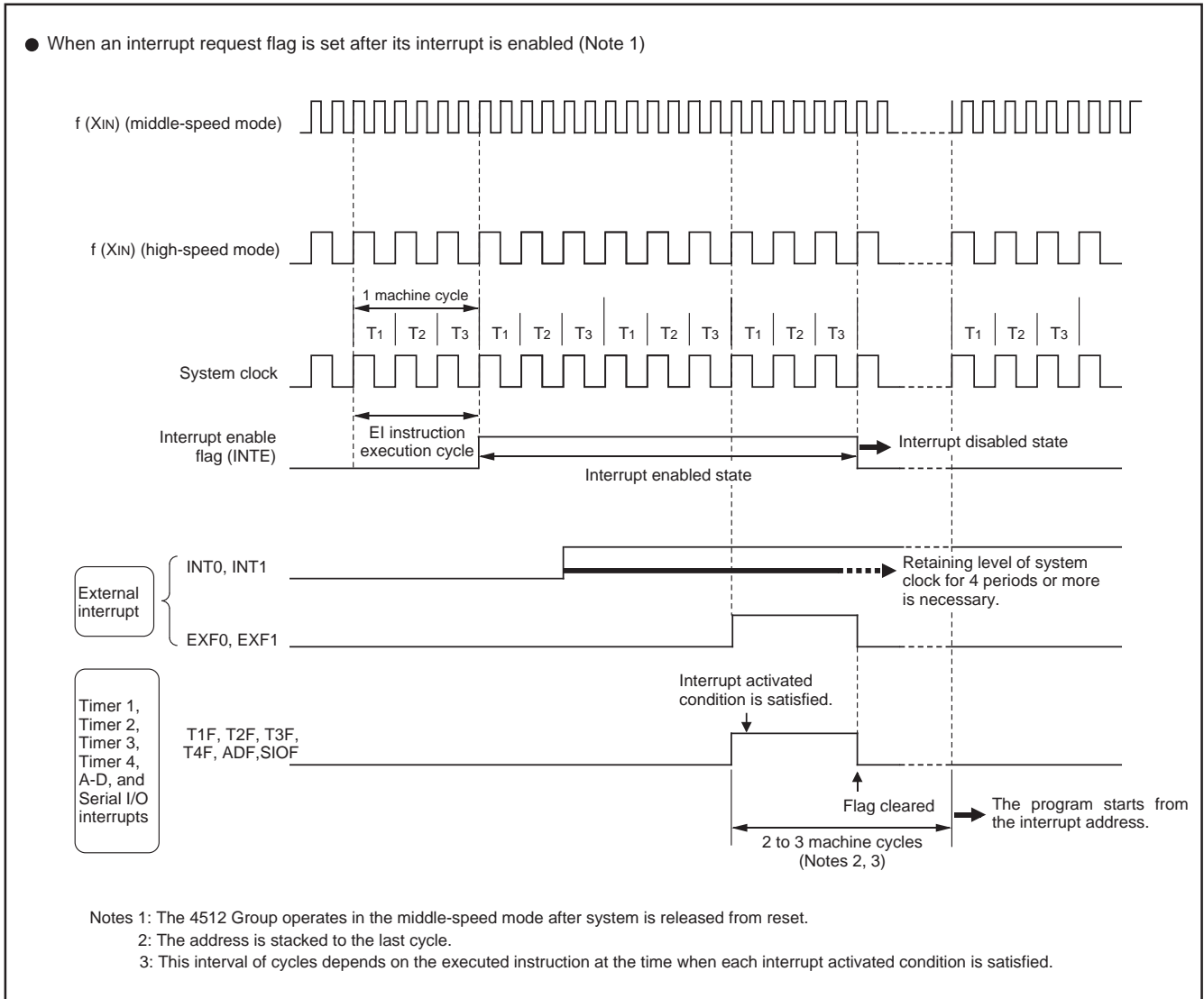

Fig. 16 Interrupt sequence

PRELIMINARY
 Notice: This is not a final specification.
 Some parametric limits are subject to change.

EXTERNAL INTERRUPTS

The 4512 Group has two external interrupts (external 0 and external 1). An external interrupt request occurs when a valid waveform is input to an interrupt input pin (edge detection).

The external interrupts can be controlled with the interrupt control registers I1 and I2.

Table 7 External interrupt activated conditions

Name	Input pin	Activated condition	Valid waveform selection bit
External 0 interrupt	INT0	When the next waveform is input to INT0 pin • Falling waveform ("H"→"L") • Rising waveform ("L"→"H") • Both rising and falling waveforms	I11 I12
External 1 interrupt	INT1	When the next waveform is input to INT1 pin • Falling waveform ("H"→"L") • Rising waveform ("L"→"H") • Both rising and falling waveforms	I21 I22

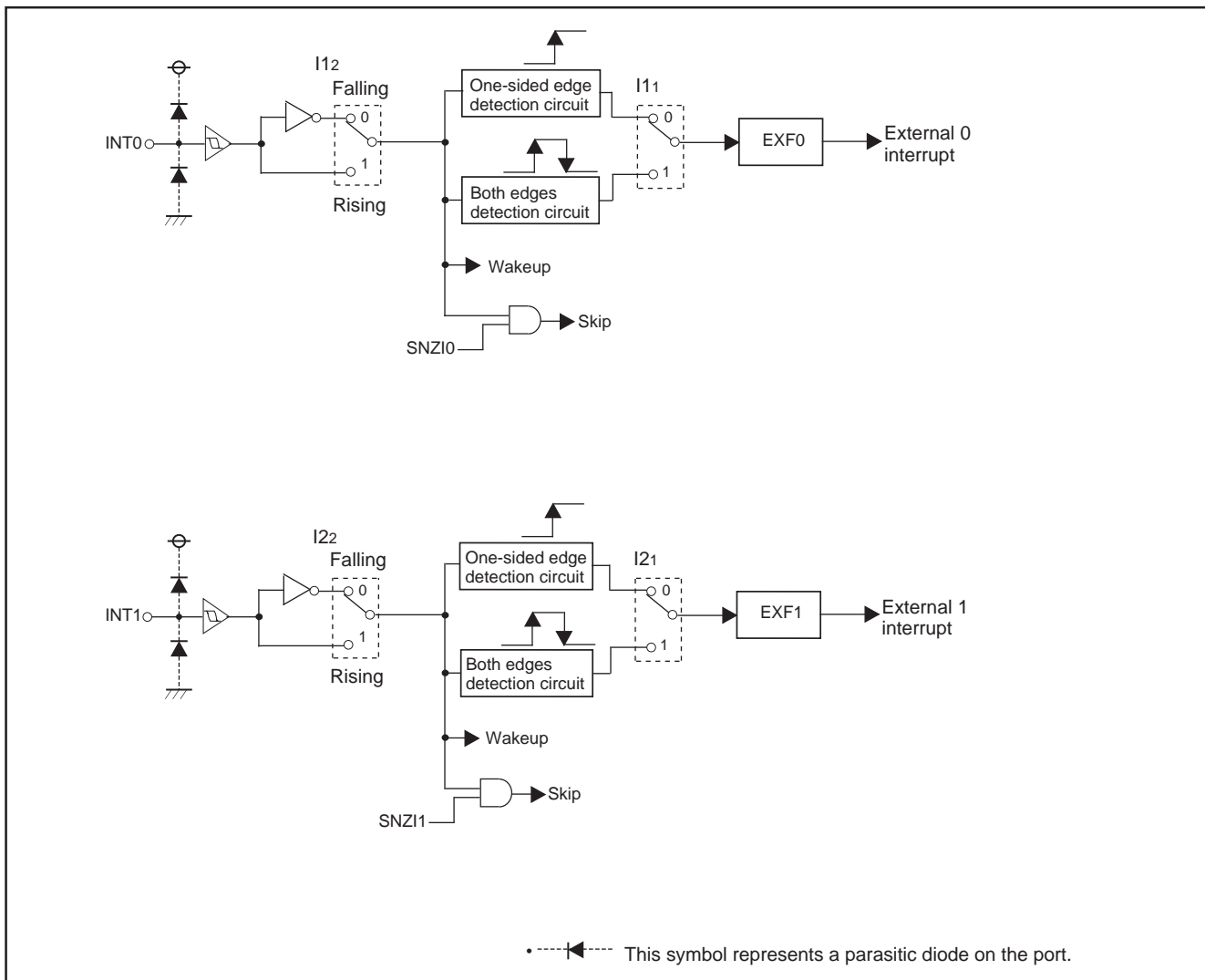

Fig. 17 External interrupt circuit structure

PRELIMINARY
 Notice: This is not a final specification.
 Some parametric limits are subject to
 change.

(1) External 0 interrupt request flag (EXF0)

External 0 interrupt request flag (EXF0) is set to "1" when a valid waveform is input to INT0 pin.

The valid waveforms causing the interrupt must be retained at their level for 4 clock cycles or more of the system clock (Refer to Figure 16).

The state of EXF0 flag can be examined with the skip instruction (SNZ0). Use the interrupt control register V1 to select the interrupt or the skip instruction. The EXF0 flag is cleared to "0" when an interrupt occurs or when the next instruction is skipped with the skip instruction.

- External 0 interrupt activated condition

External 0 interrupt activated condition is satisfied when a valid waveform is input to INT0 pin.

The valid waveform can be selected from rising waveform, falling waveform or both rising and falling waveforms. An example of how to use the external 0 interrupt is as follows.

- ① Select the valid waveform with the bits 1 and 2 of register I1.
- ② Clear the EXF0 flag to "0" with the SNZ0 instruction.
- ③ Set the NOP instruction for the case when a skip is performed with the SNZ0 instruction.
- ④ Set both the external 0 interrupt enable bit (V10) and the INTE flag to "1."

The external 0 interrupt is now enabled. Now when a valid waveform is input to the INT0 pin, the EXF0 flag is set to "1" and the external 0 interrupt occurs.

(2) External 1 interrupt request flag (EXF1)

External 1 interrupt request flag (EXF1) is set to "1" when a valid waveform is input to INT1 pin.

The valid waveforms causing the interrupt must be retained at their level for 4 clock cycles or more of the system clock (Refer to Figure 16).

The state of EXF1 flag can be examined with the skip instruction (SNZ1). Use the interrupt control register V1 to select the interrupt or the skip instruction. The EXF1 flag is cleared to "0" when an interrupt occurs or when the next instruction is skipped with the skip instruction.

- External 1 interrupt activated condition

External 1 interrupt activated condition is satisfied when a valid waveform is input to INT1 pin.

The valid waveform can be selected from rising waveform, falling waveform or both rising and falling waveforms. An example of how to use the external 1 interrupt is as follows.

- ① Select the valid waveform with the bits 1 and 2 of register I2.
- ② Clear the EXF1 flag to "0" with the SNZ1 instruction.
- ③ Set the NOP instruction for the case when a skip is performed with the SNZ1 instruction.
- ④ Set both the external 1 interrupt enable bit (V11) and the INTE flag to "1."

The external 1 interrupt is now enabled. Now when a valid waveform is input to the INT1 pin, the EXF1 flag is set to "1" and the external 1 interrupt occurs.

PRELIMINARY
 Notice: This is not a final specification.
 Some parametric limits are subject to
 change.

(3) External interrupt control registers

• Interrupt control register I1

Register I1 controls the valid waveform for the external 0 interrupt. Set the contents of this register through register A with the TI1A instruction. The TAI1 instruction can be used to transfer the contents of register I1 to register A.

• Interrupt control register I2

Register I2 controls the valid waveform for the external 1 interrupt. Set the contents of this register through register A with the TI2A instruction. The TAI2 instruction can be used to transfer the contents of register I2 to register A.

Table 8 External interrupt control registers

Interrupt control register I1		at reset : 00002	at RAM back-up : state retained	R/W
I13	Not used	0	This bit has no function, but read/write is enabled.	
		1		
I12	Interrupt valid waveform for INT0 pin/ return level selection bit (Note 2)	0	Falling waveform ("L" level of INT0 pin is recognized with the SNZI0 instruction)/"L" level	
		1	Rising waveform ("H" level of INT0 pin is recognized with the SNZI0 instruction)/"H" level	
I11	INT0 pin edge detection circuit control bit	0	One-sided edge detected	
		1	Both edges detected	
I10	INT0 pin timer 1 control enable bit	0	Disabled	
		1	Enabled	
Interrupt control register I2		at reset : 00002	at RAM back-up : state retained	R/W
I23	Not used	0	This bit has no function, but read/write is enabled.	
		1		
I22	Interrupt valid waveform for INT1 pin/ return level selection bit (Note 3)	0	Falling waveform ("L" level of INT1 pin is recognized with the SNZI1 instruction)/"L" level	
		1	Rising waveform ("H" level of INT1 pin is recognized with the SNZI1 instruction)/"H" level	
I21	INT1 pin edge detection circuit control bit	0	One-sided edge detected	
		1	Both edges detected	
I20	INT1 pin timer 3 control enable bit	0	Disabled	
		1	Enabled	

Notes 1: "R" represents read enabled, and "W" represents write enabled.

2: When the contents of I12 is changed, the external interrupt request flag EXF0 may be set. Accordingly, clear EXF0 flag with the SNZ0 instruction.

3: When the contents of I22 is changed, the external interrupt request flag EXF1 may be set. Accordingly, clear EXF1 flag with the SNZ1 instruction.

PRELIMINARY
 Notice: This is not a final specification.
 Some parametric limits are subject to
 change.

TIMERS

The 4512 Group has the following timers.

- Programmable timer

The programmable timer has a reload register and enables the frequency dividing ratio to be set. It is decremented from a setting value n . When it underflows (count to $n + 1$), a timer interrupt request flag is set to "1," new data is loaded from the reload register, and count continues (auto-reload function).

- Fixed dividing frequency timer

The fixed dividing frequency timer has the fixed frequency dividing ratio (n). An interrupt request flag is set to "1" after every n count of a count pulse.

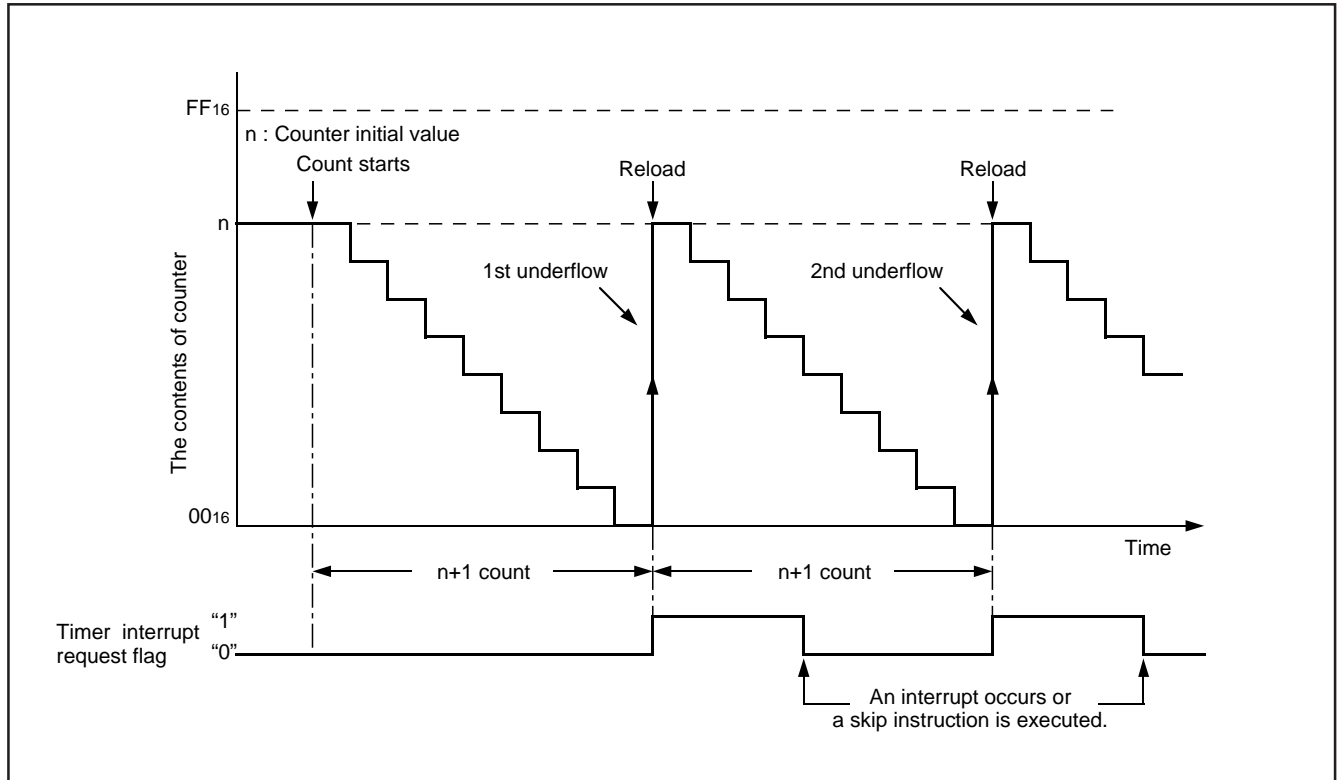

Fig. 18 Auto-reload function

PRELIMINARY
 Notice: This is not a final specification.
 Some parametric limits are subject to
 change.

The 4512 Group timer consists of the following circuits.

- Prescaler : frequency divider
- Timer 1 : 8-bit programmable timer
- Timer 2 : 8-bit programmable timer
- Timer 3 : 8-bit programmable timer
- Timer 4 : 8-bit programmable timer
- (Timers 1 to 4 have the interrupt function, respectively)
- 16-bit timer

Prescaler and timers 1 to 4 can be controlled with the timer control registers W1 to W4. The 16-bit timer is a free counter which is not controlled with the control register.

Each function is described below.

Table 9 Function related timers

Circuit	Structure	Count source	Frequency dividing ratio	Use of output signal	Control register
Prescaler	Frequency divider	• Instruction clock	4, 16	• Timer 1, 2, 3 and 4 count sources	W1
Timer 1	8-bit programmable binary down counter (link to INT0 input)	• Prescaler output (ORCLK)	1 to 256	• Timer 2 count source • Timer 1 interrupt	W1
Timer 2	8-bit programmable binary down counter	• Timer 1 underflow • Prescaler output (ORCLK) • 16-bit timer underflow	1 to 256	• Timer 3 count source • Timer 2 interrupt	W2
Timer 3	8-bit programmable binary down counter (link to INT1 input)	• Timer 2 underflow • Prescaler output (ORCLK)	1 to 256	• Timer 4 count source • Timer 3 interrupt	W3
Timer 4	8-bit programmable binary down counter	• Timer 3 underflow • Prescaler output (ORCLK)	1 to 256	• Timer 4 interrupt	W4
16-bit timer	16-bit fixed dividing frequency	• Instruction clock	65536	• Watchdog timer (The 15th bit is counted twice) • Timer 2 count source (16-bit timer underflow)	

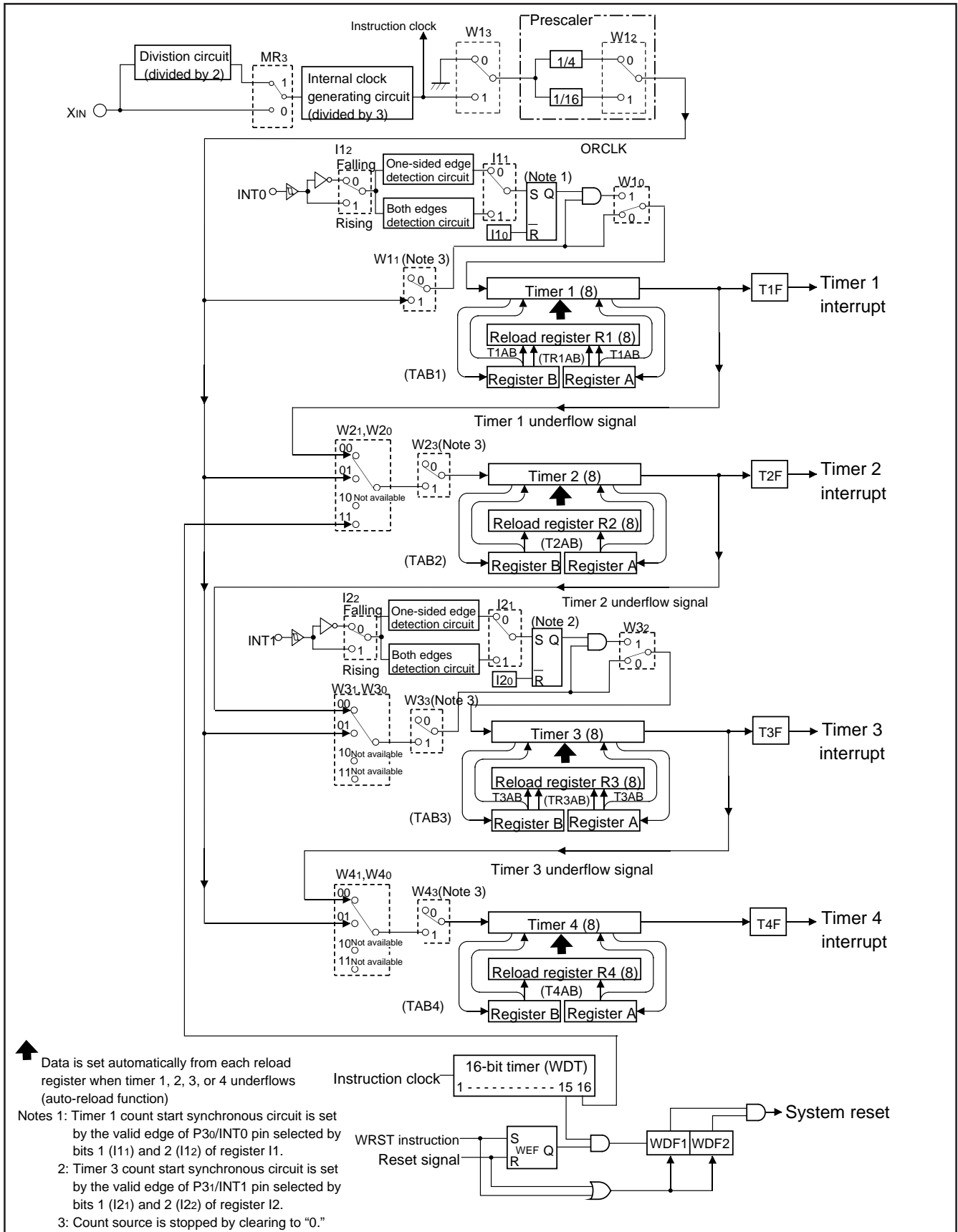

Fig. 19 Timers structure

PRELIMINARY
 Notice: This is not a final specification.
 Some parametric limits are subject to
 change.

Table 10 Timer control registers

Timer control register W1		at reset : 0000 ₂		at RAM back-up : 0000 ₂		R/W
W13	Prescaler control bit	0	Stop (state initialized)			
		1	Operating			
W12	Prescaler dividing ratio selection bit	0	Instruction clock divided by 4			
		1	Instruction clock divided by 16			
W11	Timer 1 control bit	0	Stop (state retained)			
		1	Operating			
W10	Timer 1 count start synchronous circuit control bit	0	Count start synchronous circuit not selected			
		1	Count start synchronous circuit selected			
Timer control register W2		at reset : 0000 ₂		at RAM back-up : state retained		R/W
W23	Timer 2 control bit	0	Stop (state retained)			
		1	Operating			
W22	Not used	0	This bit has no function, but read/write is enabled.			
		1				
W21	Timer 2 count source selection bits	W21 W20		Count source		
		0	0	Timer 1 underflow signal		
0		1	Prescaler output			
W20		1	0	Not available		
	1	1	16 bit timer (WDT) underflow signal			
Timer control register W3		at reset : 0000 ₂		at RAM back-up : state retained		R/W
W33	Timer 3 control bit	0	Stop (state retained)			
		1	Operating			
W32	Timer 3 count start synchronous circuit control bit	0	Count start synchronous circuit not selected			
		1	Count start synchronous circuit selected			
W31	Timer 3 count source selection bits	W31 W30		Count source		
		0	0	Timer 2 underflow signal		
0		1	Prescaler output			
W30		1	0	Not available		
	1	1	Not available			
Timer control register W4		at reset : 0000 ₂		at RAM back-up : state retained		R/W
W43	Timer 4 control bit	0	Stop (state retained)			
		1	Operating			
W42	Not used	0	This bit has no function, but read/write is enabled.			
		1				
W41	Timer 4 count source selection bits	W41 W40		Count source		
		0	0	Timer 3 underflow signal		
0		1	Prescaler output			
W40		1	0	Not available		
	1	1	Not available			

Note: "R" represents read enabled, and "W" represents write enabled.

PRELIMINARY
 Notice: This is not a final specification.
 Some parametric limits are subject to
 change.

(1) Timer control registers

- **Timer control register W1**
 Register W1 controls the count operation of timer 1, the selection of count start synchronous circuit, and the frequency dividing ratio and count operation of prescaler. Set the contents of this register through register A with the TW1A instruction. The TAW1 instruction can be used to transfer the contents of register W1 to register A.
- **Timer control register W2**
 Register W2 controls the count operation and count source of timer 2. Set the contents of this register through register A with the TW2A instruction. The TAW2 instruction can be used to transfer the contents of register W2 to register A.
- **Timer control register W3**
 Register W3 controls the count operation and count source of timer 3 and the selection of count start synchronous circuit. Set the contents of this register through register A with the TW3A instruction. The TAW3 instruction can be used to transfer the contents of register W3 to register A.
- **Timer control register W4**
 Register W4 controls the count operation and count source of timer 4. Set the contents of this register through register A with the TW4A instruction. The TAW4 instruction can be used to transfer the contents of register W4 to register A.

(2) Precautions

Note the following for the use of timers.

- **Prescaler**
 Stop the prescaler operation to change its frequency dividing ratio.
- **Count source**
 Stop timer 1, 2, 3, or 4 counting to change its count source.
- **Reading the count value**
 Stop timer 1, 2, 3, or 4 counting and then execute the TAB1, TAB2, TAB3, or TAB4 instruction to read its data.
- **Writing to reload registers R1 and R3**
 When writing data to reload registers R1 or R3 while timer 1 or timer 3 is operating, avoid a timing when timer 1 or timer 3 underflows.

(3) Prescaler

Prescaler is a frequency divider. Its frequency dividing ratio can be selected. The count source of prescaler is the instruction clock.

Use the bit 2 of register W1 to select the prescaler dividing ratio and the bit 3 to start and stop its operation. Prescaler is initialized, and the output signal (ORCLK) stops when the bit 3 of register W1 is cleared to "0."

(4) Timer 1 (interrupt function)

Timer 1 is an 8-bit binary down counter with the timer 1 reload register (R1). Data can be set simultaneously in timer 1 and the reload register (R1) with the T1AB instruction. Data can be written to reload register (R1) with the TR1AB instruction.

When writing data to reload register R1 with the TR1AB instruction, the downcount after the underflow is started from the setting value of reload register R1.

Timer 1 starts counting after the following process;

- ① set data in timer 1, and
- ② set the bit 1 of register W1 to "1."

However, INTO pin input can be used as the start trigger for timer 1 count operation by setting the bit 0 of register W1 to "1."

When a value set is n , timer 1 divides the count source signal by $n + 1$ ($n = 0$ to 255).

Once count is started, when timer 1 underflows (the next count pulse is input after the contents of timer 1 becomes "0"), the timer 1 interrupt request flag (T1F) is set to "1," new data is loaded from reload register R1, and count continues (auto-reload function).

Data can be read from timer 1 with the TAB1 instruction. When reading the data, stop the counter and then execute the TAB1 instruction.

(5) Timer 2 (interrupt function)

Timer 2 is an 8-bit binary down counter with the timer 2 reload register (R2). Data can be set simultaneously in timer 2 and the reload register (R2) with the T2AB instruction.

Timer 2 starts counting after the following process;

- ① set data in timer 2,
- ② select the count source with the bits 0 and 1 of register W2, and
- ③ set the bit 3 of register W2 to "1."

When a value set is n , timer 2 divides the count source signal by $n + 1$ ($n = 0$ to 255).

Once count is started, when timer 2 underflows (the next count pulse is input after the contents of timer 2 becomes "0"), the timer 2 interrupt request flag (T2F) is set to "1," new data is loaded from reload register R2, and count continues (auto-reload function).

Data can be read from timer 2 with the TAB2 instruction. When reading the data, stop the counter and then execute the TAB2 instruction.

PRELIMINARY
 Notice: This is not a final specification.
 Some parametric limits are subject to
 change.

(6) Timer 3 (interrupt function)

Timer 3 is an 8-bit binary down counter with the timer 3 reload register (R3). Data can be set simultaneously in timer 3 and the reload register (R3) with the T3AB instruction. Data can be written to reload register (R3) with the TR3AB instruction.

When writing data to reload register R3 with the TR3AB instruction, the downcount after the underflow is started from the setting value of reload register R3.

Timer 3 starts counting after the following process;

- ① set data in timer 3,
- ② select the count source with the bits 0 and 1 of register W3, and
- ③ set the bit 3 of register W3 to "1."

However, INT1 pin input can be used as the start trigger for timer 3 count operation by setting the bit 2 of register W3 to "1."

When a value set is n , timer 3 divides the count source signal by $n + 1$ ($n = 0$ to 255).

Once count is started, when timer 3 underflows (the next count pulse is input after the contents of timer 3 becomes "0"), the timer 3 interrupt request flag (T3F) is set to "1," new data is loaded from reload register R3, and count continues (auto-reload function).

Data can be read from timer 3 with the TAB3 instruction. When reading the data, stop the counter and then execute the TAB3 instruction.

(7) Timer 4 (interrupt function)

Timer 4 is an 8-bit binary down counter with the timer 4 reload register (R4). Data can be set simultaneously in timer 4 and the reload register (R4) with the T4AB instruction.

Timer 4 starts counting after the following process;

- ① set data in timer 4,
- ② select the count source with the bits 0 and 1 of register W4, and
- ③ set the bit 3 of register W4 to "1."

When a value set is n , timer 4 divides the count source signal by $n + 1$ ($n = 0$ to 255).

Once count is started, when timer 4 underflows (the next count pulse is input after the contents of timer 4 becomes "0"), the timer 4 interrupt request flag (T4F) is set to "1," new data is loaded from reload register R4, and count continues (auto-reload function).

Data can be read from timer 4 with the TAB4 instruction. When reading the data, stop the counter and then execute the TAB4 instruction.

(8) Timer interrupt request flags (T1F, T2F, T3F, and T4F)

Each timer interrupt request flag is set to "1" when each timer underflows. The state of these flags can be examined with the skip instructions (SNZT1, SNZT2, SNZT3, and SNZT4).

Use the interrupt control registers V1, V2 to select an interrupt or a skip instruction.

An interrupt request flag is cleared to "0" when an interrupt occurs or when the next instruction is skipped with a skip instruction.

(9) Count start synchronization circuit (timer 1, timer 3)

Each of timer 1 and timer 3 has the count start synchronous circuit which synchronizes P30/INT0 pin and P31/INT1 pin, respectively, and can start the timer count operation.

Timer 1 count start synchronous circuit function is selected by setting the bit 0 of register W1 to "1." The control by P30/INT0 pin input can be performed by setting the bit 0 of register I1 to "1."

The count start synchronous circuit is set by level change ("H"→"L" or "L"→"H") of P30/INT0 pin input. This valid waveform is selected by bits 1 (I11) and 2 (I12) of register I1 as follows;

- I11 = "0": Synchronized with one-sided edge (falling or rising)
- I11 = "1": Synchronized with both edges (both falling and rising)

When register I11="0" (synchronized with the one-sided edge), the rising or falling waveform can be selected by bit 2 of register I1;

- I12 = "0": Falling waveform
- I12 = "1": Rising waveform

Timer 3 count start synchronous circuit function is selected by setting the bit 2 of register W3 to "1." The control by P31/INT1 pin input can be performed by setting the bit 0 of register I2 to "1."

The count start synchronous circuit is set by level change ("H"→"L" or "L"→"H") of P31/INT1 pin input. This valid waveform is selected by bits 1 (I21) and 2 (I22) of register I2 as follows;

- I21 = "0": Synchronized with one-sided edge (falling or rising)
- I21 = "1": Synchronized with both edges (both falling and rising)

When register I21="0" (synchronized with the one-sided edge), the rising or falling waveform can be selected by bit 2 of register I2;

- I22 = "0": Falling waveform
- I22 = "1": Rising waveform

When timer 1 and timer 3 count start synchronous circuits are used, the count start synchronous circuits are set, the count source is input to each timer by inputting valid waveform to P30/INT0 pin and P31/INT1 pin. Once set, the count start synchronous circuit is cleared by clearing the bit I10 or I20 to "0" or reset.

PRELIMINARY
 Notice: This is not a final specification.
 Some parametric limits are subject to change.

WATCHDOG TIMER

Watchdog timer provides a method to reset the system when a program run-away occurs. Watchdog timer consists of a 16-bit timer (WDT), watchdog timer enable flag (WEF), and watchdog timer flags (WDF1, WDF2).

The timer WDT downcounts the instruction clocks as the count source after system is released from reset. The underflow signal is generated when the count value reaches "0000₁₆." This underflow signal can be used as the timer 2 count source.

When the WRST instruction is executed after system is released from reset, the WEF flag is set to "1". At this time, the watchdog timer starts operating.

When the count value of timer WDT reaches "BFFF₁₆" or "3FFF₁₆," the WDF1 flag is set to "1." If the WRST instruction is never executed while timer WDT counts 32767, WDF2 flag is set to "1," and the RESET pin outputs "L" level to reset the microcomputer. Execute the WRST instruction at each period of 32766 machine cycle or less by software when using watchdog timer to keep the microcomputer operating normally.

To prevent the WDT stopping in the event of misoperation, WEF flag is designed not to initialize once the WRST instruction has been executed. Note also that, if the WRST instruction is never executed, the watchdog timer does not start.

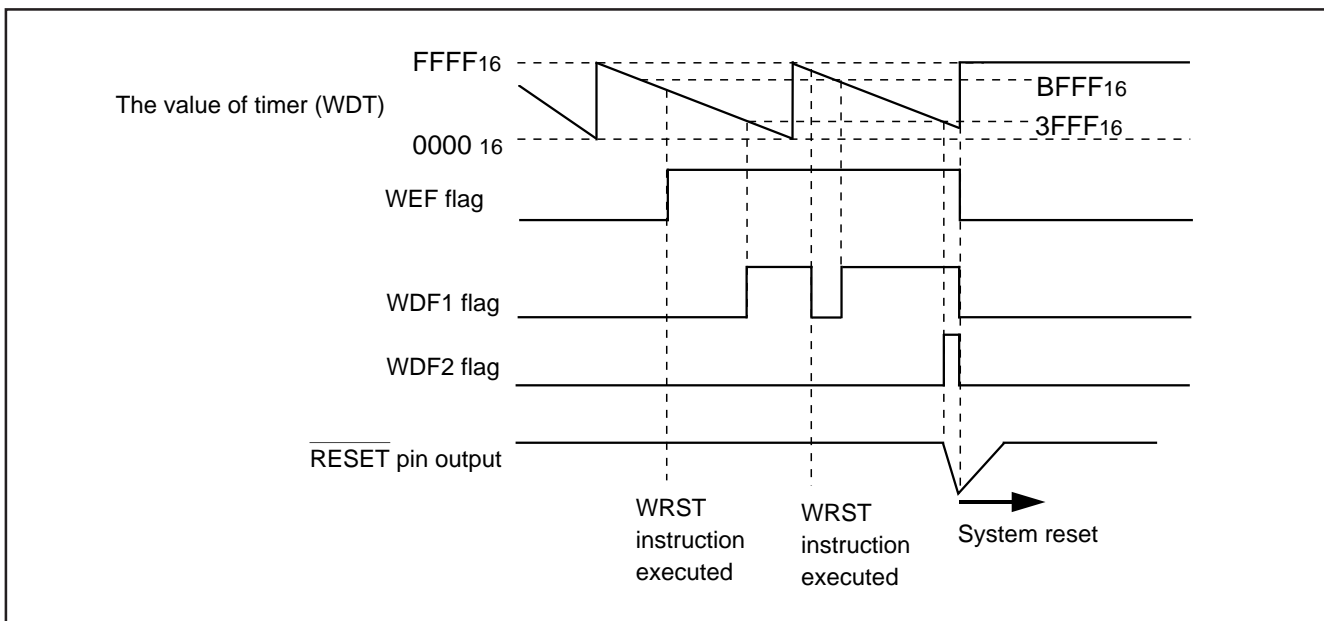

Fig. 20 Watchdog timer function

The contents of WEF, WDF1 and WDF2 flags and timer WDT are initialized at the RAM back-up mode.

If WDF2 flag is set to "1" at the same time that the microcomputer enters the RAM back-up state, system reset may be performed.

When using the watchdog timer and the RAM back-up mode, initialize the WDF1 flag with the WRST instruction just before the microcomputer enters the RAM back-up state (refer to Figure 21)

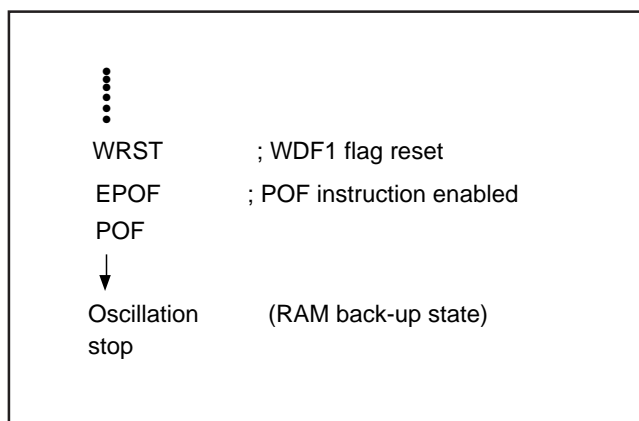

Fig. 21 Program example to enter the RAM back-up mode when using the watchdog timer

PRELIMINARY
 Notice: This is not a final specification.
 Some parametric limits are subject to change.

SERIAL I/O

The 4512 Group has a built-in clock synchronous serial I/O which can serially transmit or receive 8-bit data.

Serial I/O consists of;

- serial I/O register SI
- serial I/O mode register J1
- serial I/O transmission/reception completion flag (SIOF)
- serial I/O counter

Registers A and B are used to perform data transfer with internal CPU, and the serial I/O pins are used for external data transfer.

The pin functions of the serial I/O pins can be set with the register J1.

Table 11 Serial I/O pins

Pin	Pin function when selecting serial I/O
P20/SCK	Clock I/O (SCK)
P21/SOUT	Serial data output (SOUT)
P22/SIN	Serial data input (SIN)

Note: Input ports P20–P22 can be used regardless of register J1.

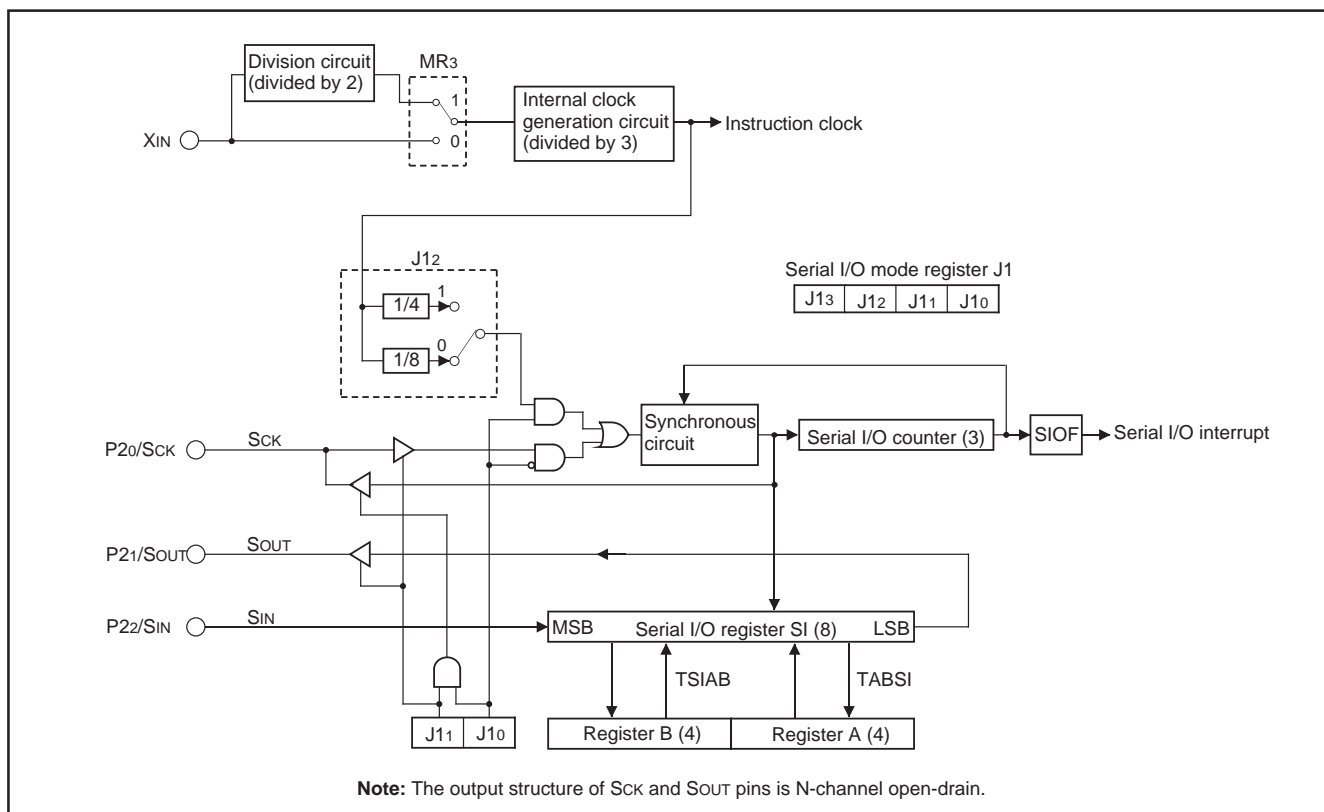

Fig. 22 Serial I/O structure

Table 12 Serial I/O mode register

Serial I/O mode register J1		at reset : 00002	at RAM back-up : state retained	R/W
J13	Not used	0 1	This bit has no function, but read/write is enabled.	
J12	Serial I/O internal clock dividing ratio selection bit	0 1		
J11	Serial I/O port selection bit	0 1	Input ports P20, P21, P22 selected Serial I/O ports SCK, SOUT, SIN/input ports P20, P21, P22 selected	
J10	Serial I/O synchronous clock selection bit	0 1	External clock Internal clock (instruction clock divided by 4 or 8)	

Note: "R" represents read enabled, and "W" represents write enabled.

PRELIMINARY
 Notice: This is not a final specification.
 Some parametric limits are subject to
 change.

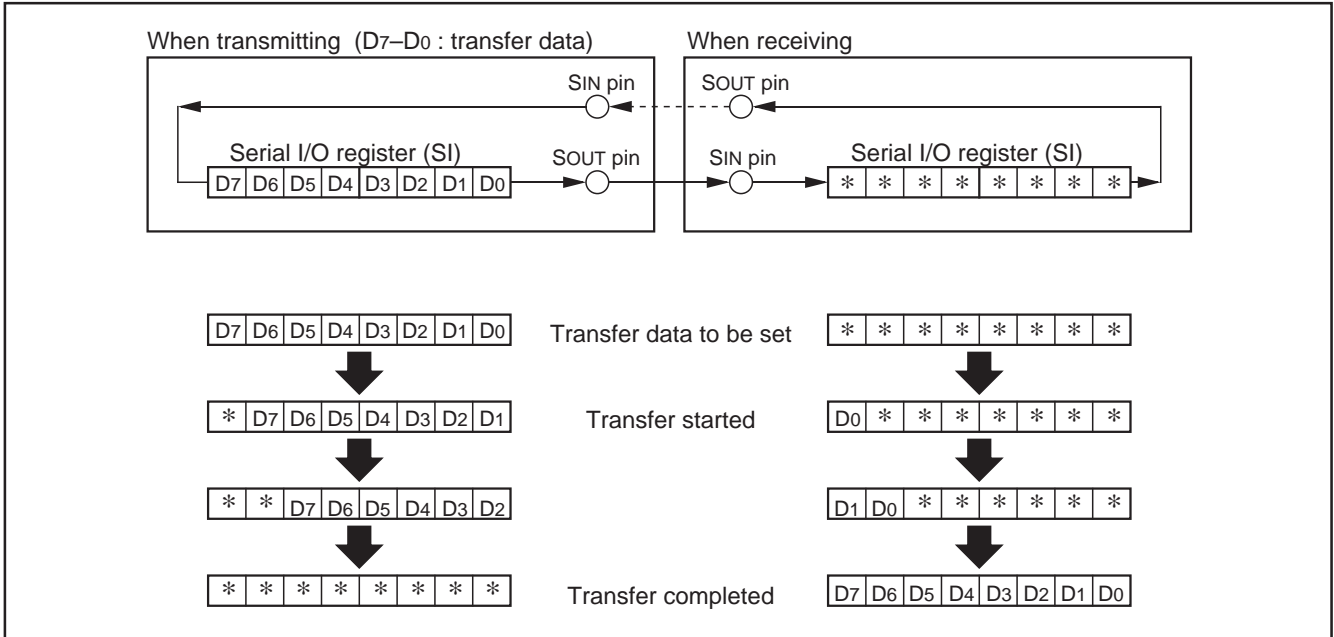

Fig. 23 Serial I/O register state when transferring

(1) Serial I/O register SI

Serial I/O register SI is the 8-bit data transfer serial/parallel conversion register. Data can be set to register SI through registers A and B with the TSIAB instruction. The contents of register A is transmitted to the low-order 4 bits of register SI, and the contents of register B is transmitted to the high-order 4 bits of register SI. During transmission, each bit data is transmitted LSB first from the lowermost bit (bit 0) of register SI, and during reception, each bit data is received LSB first to register SI starting from the topmost bit (bit 7).

When register SI is used as a work register without using serial I/O, pull up the Sck pin or set the pin function to an input port P20.

(2) Serial I/O transmission/reception completion flag (SIOF)

Serial I/O transmission/reception completion flag (SIOF) is set to "1" when serial data transmission or reception completes. The state of SIOF flag can be examined with the skip instruction (SNZSI). Use the interrupt control register V2 to select the interrupt or the skip instruction.

The SIOF flag is cleared to "0" when the interrupt occurs or when the next instruction is skipped with the skip instruction.

(3) Serial I/O start instruction (SST)

When the SST instruction is executed, the SIOF flag is cleared to "0" and then serial I/O transmission/reception is started.

(4) Serial I/O mode register J1

Register J1 controls the synchronous clock, P20/Sck, P21/Sout and P22/Sin pin function. Set the contents of this register through register A with the TJ1A instruction. The TAJ1 instruction can be used to transfer the contents of register J1 to register A.

PRELIMINARY
 Notice: This is not a final specification.
 Some parametric limits are subject to
 change.

(5) How to use serial I/O

Figure 24 shows the serial I/O connection example. Serial I/O interrupt is not used in this example. In the actual wiring, pull up the

wiring between each pin with a resistor. Figure 25 shows the data transfer timing and Table 13 shows the data transfer sequence.

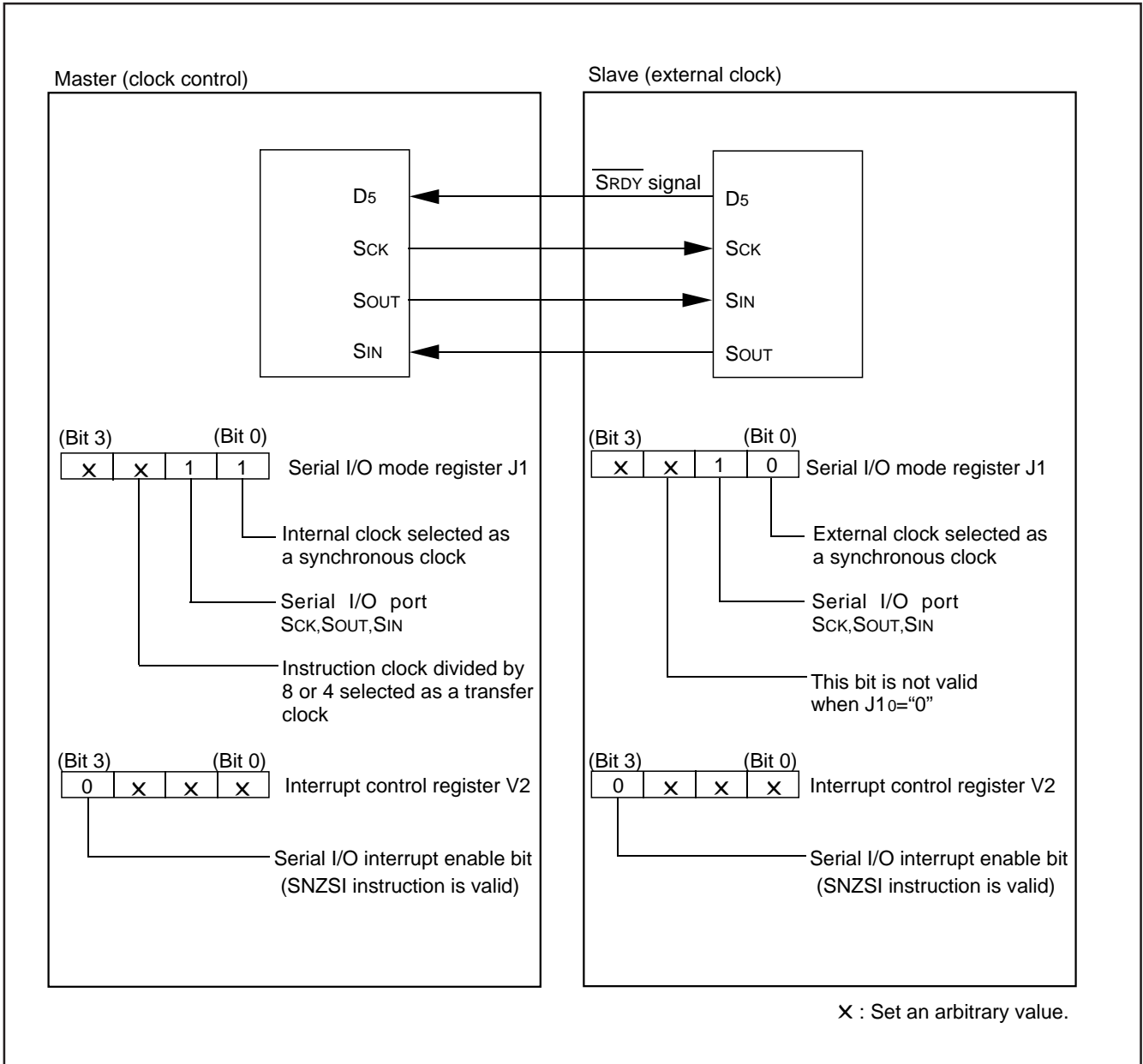

Fig. 24 Serial I/O connection example

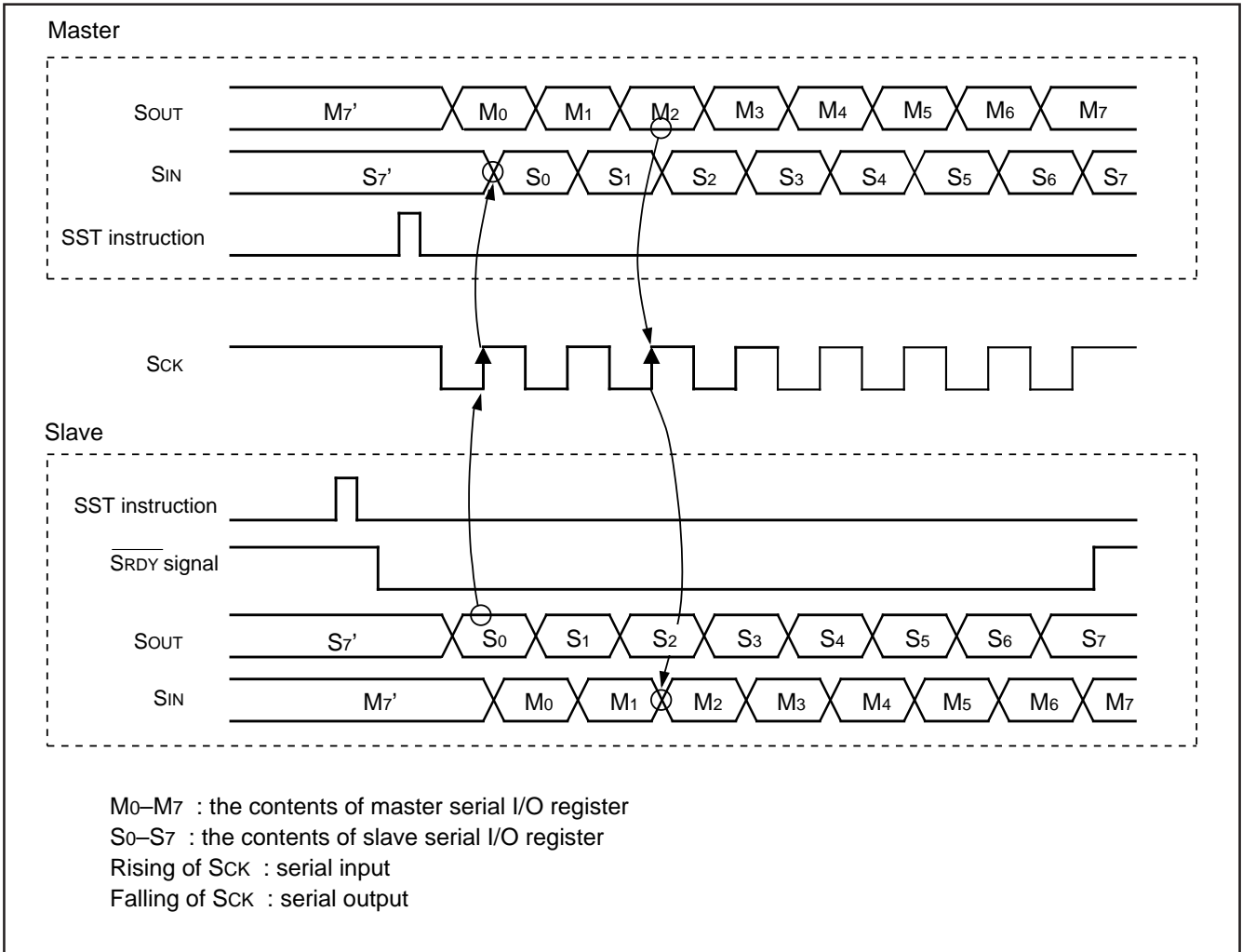

Fig. 25 Timing of serial I/O data transfer

PRELIMINARY
 Notice: This is not a final specification.
 Some parametric limits are subject to
 change.

Table 13 Processing sequence of data transfer from master to slave

Master (transmission)	Slave (reception)
[Initial setting] • Setting the serial I/O mode register J1 and interrupt control register V2 shown in Figure 24.	[Initial setting] • Setting serial I/O mode register J1, and interrupt control register V2 shown in Figure 24.
TJ1A and TV2A instructions	TJ1A and TV2A instructions
• Setting the port received the reception enable signal (SRDY) to the input mode. (Port D5 is used in this example)	• Setting the port transmitted the reception enable signal (SRDY) and outputting "H" level (reception impossible). (Port D5 is used in this example)
SD instruction	SD instruction
* [Transmission enable state] • Storing transmission data to serial I/O register SI.	*[Reception enable state] • The SIOF flag is cleared to "0."
TSIAB instruction	SST instruction
	• "L" level (reception possible) is output from port D5.
	RD instruction
[Transmission] • Check port D5 is "L" level.	[Reception]
SZD instruction	
• Serial transfer starts.	
SST instruction	
• Check transmission completes.	• Check reception completes.
SNZSI instruction	SNZSI instruction
• Wait (timing when continuously transferring)	• "H" level is output from port D5.
	SD instruction
	[Data processing]

1-byte data is serially transferred on this process. Subsequently, data can be transferred continuously by repeating the process from *.
 When an external clock is selected as a synchronous clock, the clock is not controlled internally. Control the clock externally because serial transfer is performed as long as clock is externally input. (Unlike an internal clock, an external clock is not stopped when serial transfer is completed.) However, the SIOF flag is set to "1" when the clock is counted 8 times after executing the SST instruction. Be sure to set the initial level of the external clock to "H."

PRELIMINARY
 Notice: This is not a final specification.
 Some parametric limits are subject to
 change.

A-D CONVERTER

The 4512 Group has a built-in A-D conversion circuit that performs conversion by 10-bit successive comparison method. Table 14 shows the characteristics of this A-D converter. This A-D converter can also be used as an 8-bit comparator to compare analog voltages input from the analog input pin with preset values.

Table 14 A-D converter characteristics

Parameter	Characteristics
Conversion format	Successive comparison method
Resolution	10 bits
Relative accuracy	Linearity error: $\pm 2\text{LSB}$
	Non-linearity error: $\pm 0.9\text{LSB}$
Conversion speed	46.5 μs (High-speed mode at 4.0 MHz oscillation frequency)
Analog input pin	4

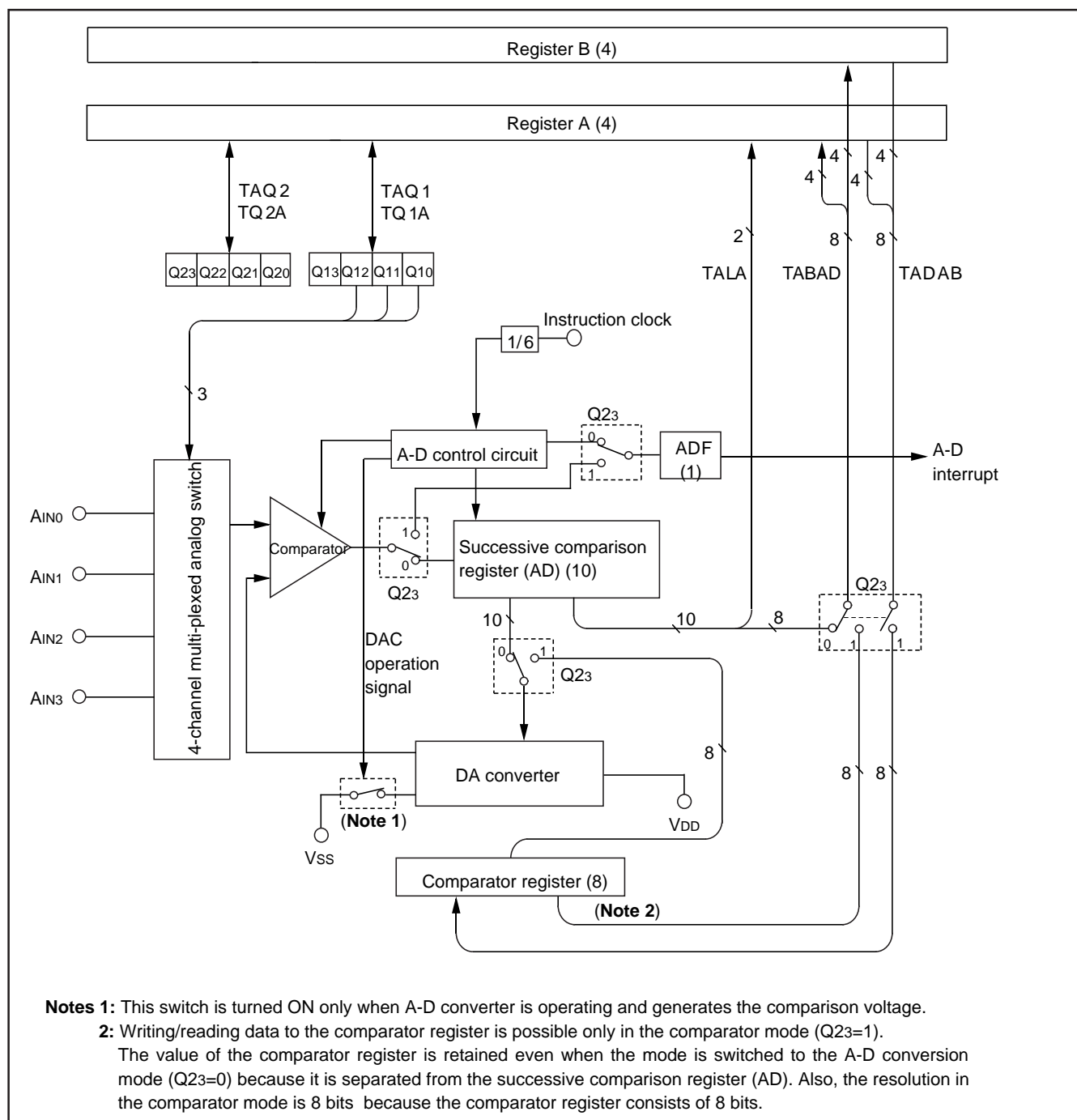

Fig. 26 A-D conversion circuit structure

PRELIMINARY
 Notice: This is not a final specification.
 Some parametric limits are subject to
 change.

Table 15 A-D control registers

A-D control register Q1		at reset : 00002		at RAM back-up : state retained	R/W
Q13	Not used	0		This bit has no function, but read/write is enabled.	
		1			
Q12	Analog input pin selection bits	Q12	Q11	Q10	Selected pins
		0	0	0	AIN0
0		0	1	AIN1	
Q11		0	1	0	AIN2
		0	1	1	AIN3
Q10		1	0	0	Not available
		1	0	1	Not available
		1	1	0	Not available
		1	1	1	Not available
A-D control register Q2		at reset : 00002		at RAM back-up : state retained	R/W
Q23	A-D operation mode selection bit	0		A-D conversion mode	
		1		Comparator mode	
Q22	Not used	0		This bit has no function, but read/write is enabled.	
		1			
Q21	Not used	0		This bit has no function, but read/write is enabled.	
		1			
Q20	Not used	0		This bit has no function, but read/write is enabled.	
		1			

Note: "R" represents read enabled, and "W" represents write enabled.

(1) Operating at A-D conversion mode

The A-D conversion mode is set by setting the bit 3 of register Q2 to "0."

(2) Successive comparison register AD

Register AD stores the A-D conversion result of an analog input in 10-bit digital data format. The contents of the high-order 8 bits of this register can be stored in register B and register A with the TABAD instruction. The contents of the low-order 2 bits of this register can be stored into the high-order 2 bits of register A with the TALA instruction. However, do not execute this instruction during A-D conversion.

When the contents of register AD is n, the logic value of the comparison voltage V_{ref} generated from the built-in DA converter can be obtained with the reference voltage V_{DD} by the following formula:

<p>Logic value of comparison voltage V_{ref}</p> $V_{ref} = \frac{V_{DD}}{1024} \times n$ <p>n: The value of register AD (n = 0 to 1023)</p>

(3) A-D conversion completion flag (ADF)

A-D conversion completion flag (ADF) is set to "1" when A-D conversion completes. The state of ADF flag can be examined with the skip instruction (SNZAD). Use the interrupt control register V2 to select the interrupt or the skip instruction.

The ADF flag is cleared to "0" when the interrupt occurs or when the next instruction is skipped with the skip instruction.

(4) A-D conversion start instruction (ADST)

A-D conversion starts when the ADST instruction is executed. The conversion result is automatically stored in the register AD.

(5) A-D control register Q1

Register Q1 is used to select one of analog input pins.

(6) A-D control register Q2

Register Q2 controls the A-D conversion mode. The A-D conversion mode is selected when the bit 3 of register Q2 is "0," and the comparator mode is selected when the bit 3 of register Q2 is "1."

PRELIMINARY
 Notice: This is not a final specification.
 Some parametric limits are subject to change.

(7) Operation description

A-D conversion is started with the A-D conversion start instruction (ADST). The internal operation during A-D conversion is as follows:

- ① When A-D conversion starts, the register AD is cleared to "00016."
- ② Next, the topmost bit of the register AD is set to "1," and the comparison voltage V_{ref} is compared with the analog input voltage V_{IN} .
- ③ When the comparison result is $V_{ref} < V_{IN}$, the topmost bit of the register AD remains set to "1." When the comparison result is $V_{ref} > V_{IN}$, it is cleared to "0."

The 4512 Group repeats this operation to the lowermost bit of the register AD to convert an analog value to a digital value. A-D conversion stops after 62 machine cycles (46.5 μs when $f(X_{IN}) = 4.0$ MHz in high-speed mode) from the start, and the conversion result is stored in the register AD. An A-D interrupt activated condition is satisfied and the ADF flag is set to "1" as soon as A-D conversion completes (Figure 27).

Table 16 Change of successive comparison register AD during A-D conversion

At starting conversion	Change of successive comparison register AD	Comparison voltage (V_{ref}) value
1st comparison	1 0 0 ---- 0 0 0	$\frac{V_{DD}}{2}$
2nd comparison	*1 1 0 ---- 0 0 0	$\frac{V_{DD}}{2} \pm \frac{V_{DD}}{4}$
3rd comparison	*1 *2 1 ---- 0 0 0	$\frac{V_{DD}}{2} \pm \frac{V_{DD}}{4} \pm \frac{V_{DD}}{8}$
After 10th comparison completes	A-D conversion result *1 *2 *3 ---- *8 *9 *A	$\frac{V_{DD}}{2} \pm \dots \pm \frac{V_{DD}}{1024}$

- *1: 1st comparison result *2: 2nd comparison result
- *3: 3rd comparison result *8: 8th comparison result
- *9: 9th comparison result *A: 10th comparison result

(8) A-D conversion timing chart

Figure 27 shows the A-D conversion timing chart.

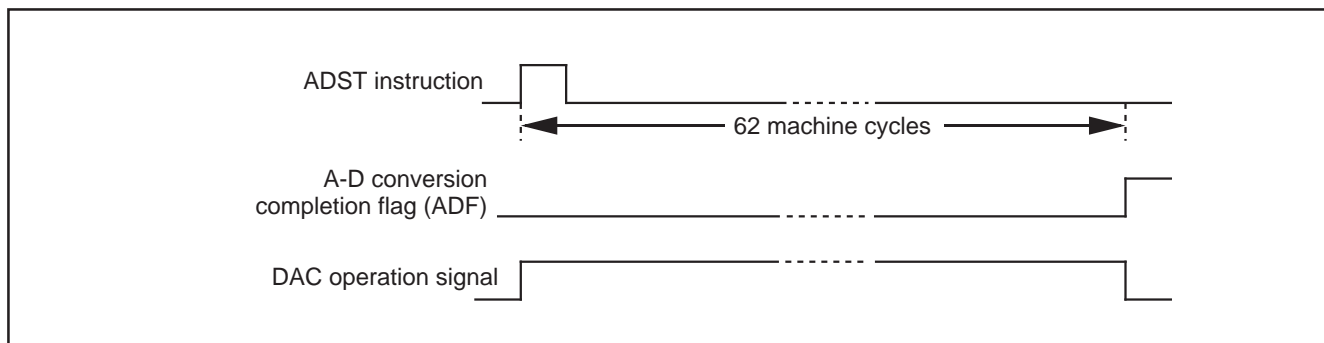

Fig. 27 A-D conversion timing chart

PRELIMINARY
 Notice: This is not a final specification.
 Some parametric limits are subject to change.

(9) Operation at comparator mode

The A-D converter is set to comparator mode by setting bit 3 of the register Q2 to "1."

Below, the operation at comparator mode is described.

(10) Comparator register

In comparator mode, the built-in DA comparator is connected to the comparator register as a register for setting comparison voltages. The contents of register B is stored in the high-order 4 bits of the comparator register and the contents of register A is stored in the low-order 4 bits of the comparator register with the TADAB instruction.

When changing from A-D conversion mode to comparator mode, the result of A-D conversion (register AD) is undefined.

However, because the comparator register is separated from register AD, the value is retained even when changing from comparator mode to A-D conversion mode. Note that the comparator register can be written and read at only comparator mode.

If the value in the comparator register is n, the logic value of comparison voltage V_{ref} generated by the built-in DA converter can be determined from the following formula:

Logic value of comparison voltage V_{ref}

$$V_{ref} = \frac{V_{DD}}{256} \times n$$

n: The value of register AD (n = 0 to 255)

(11) Comparison result store flag (ADF)

In comparator mode, the ADF flag, which shows completion of A-D conversion, stores the results of comparing the analog input voltage with the comparison voltage. When the analog input voltage is lower than the comparison voltage, the ADF flag is set to "1." The state of ADF flag can be examined with the skip instruction (SNZAD). Use the interrupt control register V2 to select the interrupt or the skip instruction.

The ADF flag is cleared to "0" when the interrupt occurs or when the next instruction is skipped with the skip instruction.

(12) Comparator operation start instruction (ADST instruction) (Figure 28)

In comparator mode, executing ADST starts the comparator operating.

The comparator stops 8 machine cycles after it has started (6 μ s at $f(XIN) = 4.0$ MHz in high-speed mode). When the analog input voltage is lower than the comparison voltage, the ADF flag is set to "1."

(13) Notes for the use of A-D conversion 1

- TALA instruction
 When the TALA instruction is executed, the low-order 2 bits of register AD is transferred to the high-order 2 bits of register A, simultaneously, the low-order 2 bits of register A is "0."

(14) Notes for the use of A-D conversion 2

Do not change the operating mode (both A-D conversion mode and comparator mode) of A-D converter with bit 3 of register Q2 while A-D converter is operating.

When the operating mode of A-D converter is changed from the comparator mode to A-D conversion mode with the bit 3 of register Q2, note the following;

- Clear bit 2 of register V2 to "0" to change the operating mode of the A-D converter from the comparator mode to A-D conversion mode with the bit 3 of register Q2.
- The A-D conversion completion flag (ADF) may be set when the operating mode of the A-D converter is changed from the comparator mode to the A-D conversion mode. Accordingly, set a value to register Q2, and execute the SNZAD instruction to clear the ADF flag.

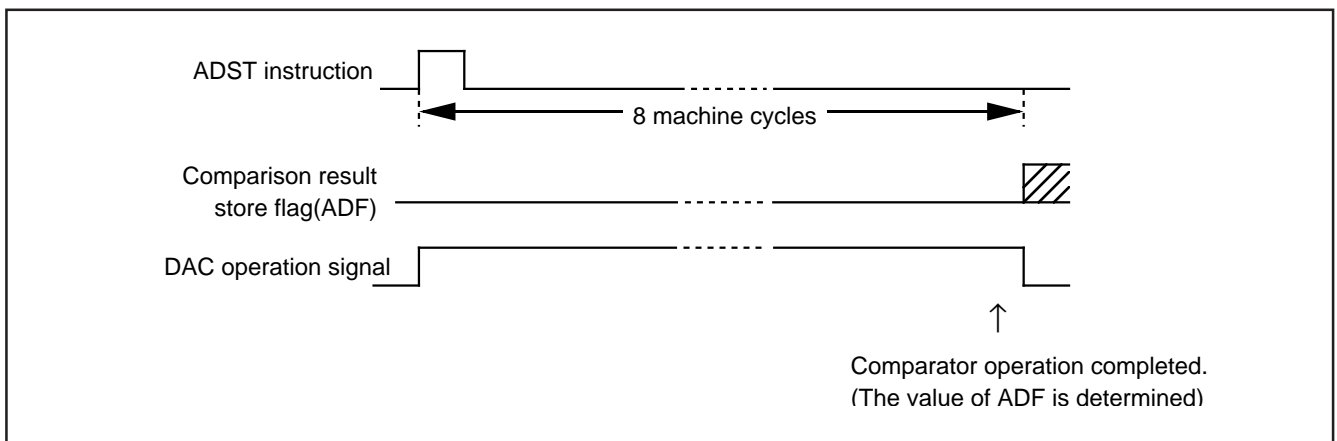

Fig. 28 Comparator operation timing chart

PRELIMINARY
 Notice: This is not a final specification.
 Some parametric limits are subject to change.

(15) Definition of A-D converter accuracy

The A-D conversion accuracy is defined below (refer to Figure 29).

- Relative accuracy
 - ① Zero transition voltage (V_{0T})
 This means an analog input voltage when the actual A-D conversion output data changes from "0" to "1."
 - ② Full-scale transition voltage (V_{FST})
 This means an analog input voltage when the actual A-D conversion output data changes from "1023" to "1022."
 - ③ Linearity error
 This means a deviation from the line between V_{0T} and V_{FST} of a converted value between V_{0T} and V_{FST}.
 - ④ Differential non-linearity error
 This means a deviation from the input potential difference required to change a converter value between V_{0T} and V_{FST} by 1 LSB at the relative accuracy.

- Absolute accuracy
 This means a deviation from the ideal characteristics between 0 to V_{DD} of actual A-D conversion characteristics.

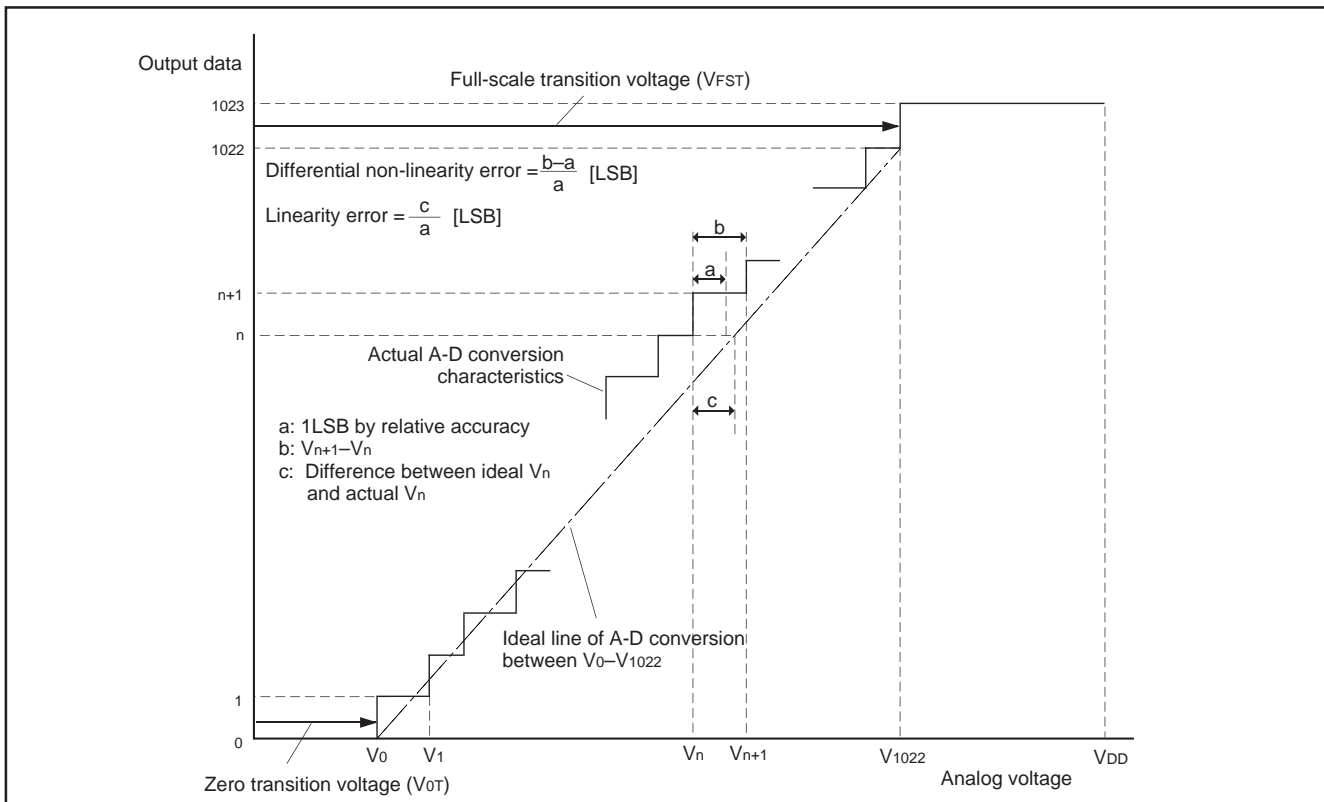

Fig. 29 Definition of A-D conversion accuracy

V_n: Analog input voltage when the output data changes from "n" to "n+1" (n = 0 to 1022)

- 1LSB at relative accuracy $\rightarrow \frac{V_{FST}-V_{0T}}{1022}$ (V)

- 1LSB at absolute accuracy $\rightarrow \frac{V_{DD}}{1024}$ (V)

PRELIMINARY
 Notice: This is not a final specification.
 Some parametric limits are subject to change.

RESET FUNCTION

System reset is performed by applying "L" level to $\overline{\text{RESET}}$ pin for 1 machine cycle or more when the following condition is satisfied; the value of supply voltage is the minimum value or more of the recommended operating conditions.
 Then when "H" level is applied to $\overline{\text{RESET}}$ pin, software starts from address 0 in page 0.

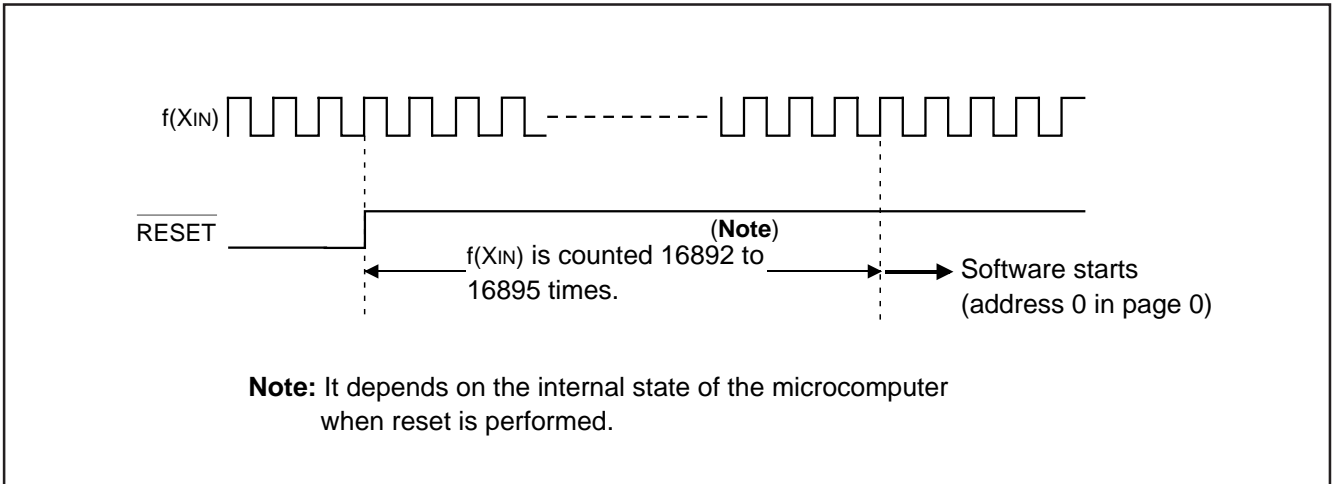

Fig. 30 Reset release timing

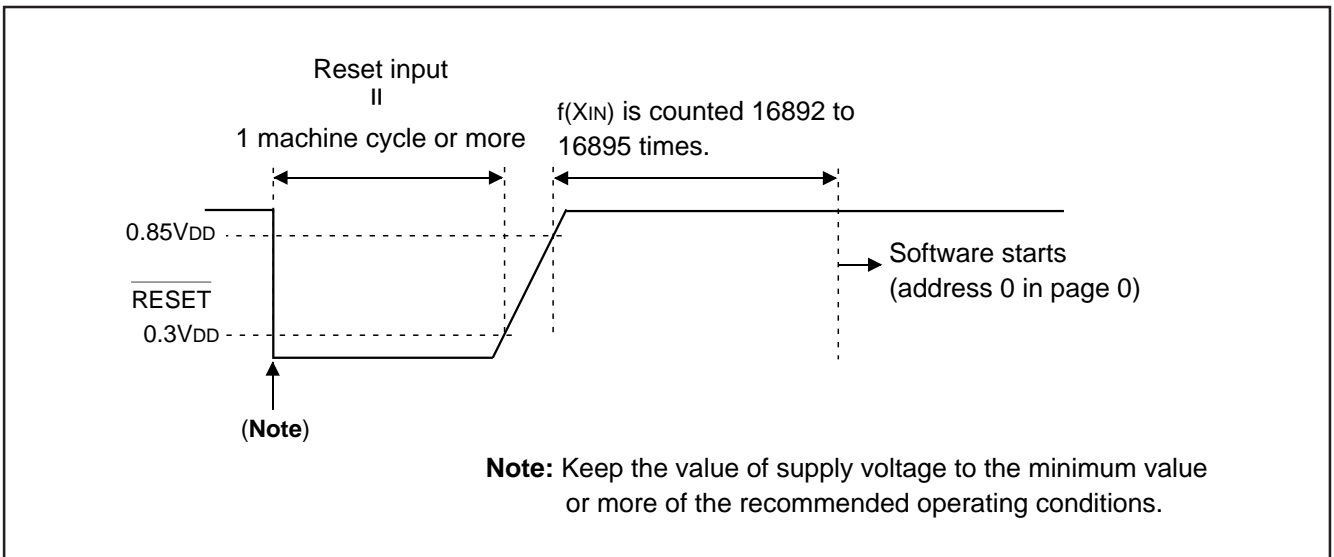

Fig. 31 $\overline{\text{RESET}}$ pin input waveform and reset operation

PRELIMINARY
 Notice: This is not a final specification.
 Some parametric limits are subject to change.

(1) Power-on reset

Reset can be performed automatically at power on (power-on reset) by connecting resistors, a diode, and a capacitor to RESET pin. Connect RESET pin and the external circuit at the shortest distance.

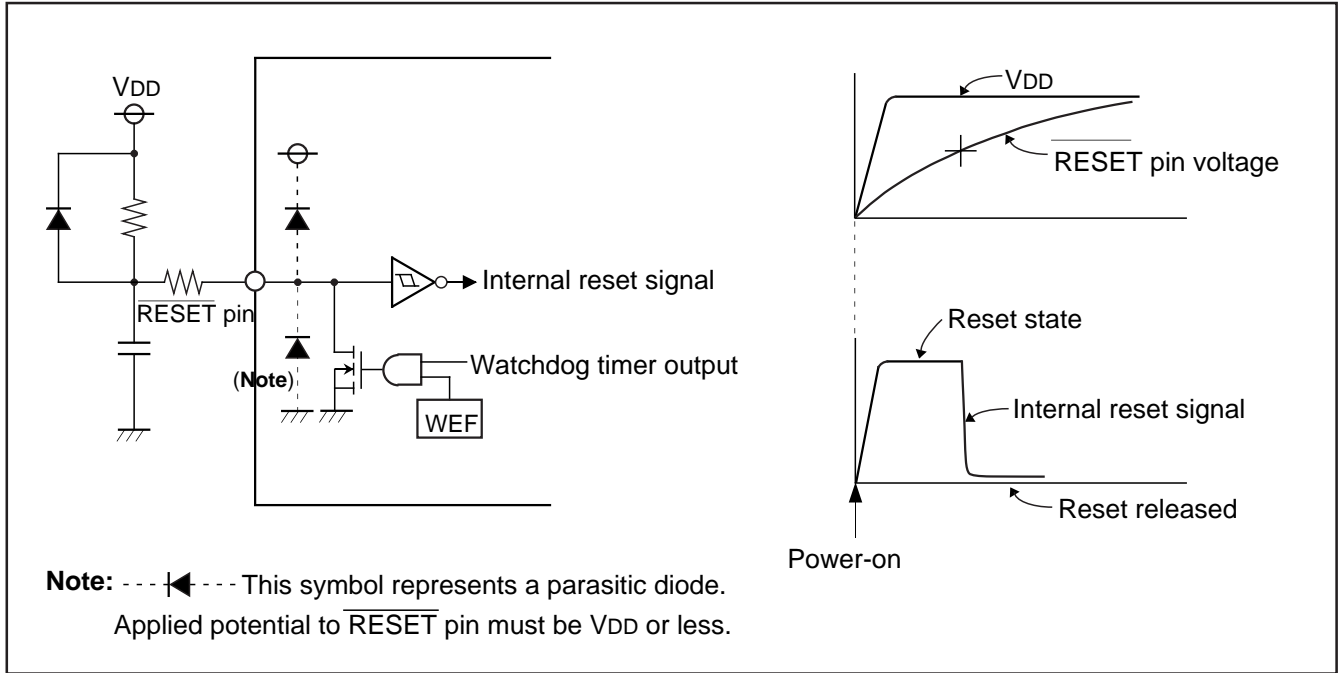

Fig. 32 Power-on reset circuit example

(2) Internal state at reset

Table 17 shows port state at reset, and Figure 33 shows internal state at reset (they are the same after system is released from reset). The contents of timers, registers, flags and RAM except shown in Figure 33 are undefined, so set the initial value to them.

Table 17 Port state at reset

Name	Function	State
D0-D7	D0-D7	High impedance (Note 1)
P00-P03	P00-P03	High impedance (Notes 1, 2)
P10-P13	P10-P13	
P20/Sck, P21/SOUT, P22/SIN	P20-P22	High impedance

Notes 1: Output latch is set to "1."
 2: Pull-up transistor is turned OFF.

PRELIMINARY
 Notice: This is not a final specification.
 Some parametric limits are subject to
 change.

• Program counter (PC)	0 0 0 0 0 0 0 0 0 0 0 0 0 0 0 0	
Address 0 in page 0 is set to program counter.		
• Interrupt enable flag (INTE)	0	(Interrupt disabled)
• Power down flag (P)	0	
• External 0 interrupt request flag (EXF0)	0	
• External 1 interrupt request flag (EXF1)	0	
• Interrupt control register V1	0 0 0 0	(Interrupt disabled)
• Interrupt control register V2	0 0 0 0	(Interrupt disabled)
• Interrupt control register I1	0 0 0 0	
• Interrupt control register I2	0 0 0 0	
• Timer 1 interrupt request flag (T1F)	0	
• Timer 2 interrupt request flag (T2F)	0	
• Timer 3 interrupt request flag (T3F)	0	
• Timer 4 interrupt request flag (T4F)	0	
• Watchdog timer flags (WDF1, WDF2)	0	
• Watchdog timer enable flag (WEF)	0	
• Timer control register W1	0 0 0 0	(Prescaler and timer 1 stopped)
• Timer control register W2	0 0 0 0	(Timer 2 stopped)
• Timer control register W3	0 0 0 0	(Timer 3 stopped)
• Timer control register W4	0 0 0 0	(Timer 4 stopped)
• Clock control register MR	1 0 0 0	
• Serial I/O transmission/reception completion flag (SIOF)	0	
• Serial I/O mode register J1	0 0 0 0	(External clock selected and serial I/O port not selected)
• Serial I/O register SI	X X X X X X X X	
• A-D conversion completion flag (ADF)	0	
• A-D control register Q1	0 0 0 0	
• A-D control register Q2	0 0 0 0	
• Successive comparison register AD	X X X X X X X X X X	
• Comparator register	X X X X X X X X	
• Key-on wakeup control register K0	0 0 0 0	
• Pull-up control register PU0	0 0 0 0	
• Carry flag (CY)	0	
• Register A	0 0 0 0	
• Register B	0 0 0 0	
• Register D	X X X	
• Register E	X X X X X X X X	
• Register X	0 0 0 0	
• Register Y	0 0 0 0	
• Register Z	X X	
• Stack pointer (SP)	1 1 1	

“X” represents undefined.

Fig. 33 Internal state at reset

PRELIMINARY
 Notice: This is not a final specification.
 Some parametric limits are subject to
 change.

RAM BACK-UP MODE

The 4512 Group has the RAM back-up mode.

When the EPOF and POF instructions are executed continuously, system enters the RAM back-up state. The POF instruction is equal to the NOP instruction when the EPOF instruction is not executed before the POF instruction.

As oscillation stops retaining RAM, the function of reset circuit and states at RAM back-up mode, current dissipation can be reduced without losing the contents of RAM. Table 18 shows the function and states retained at RAM back-up. Figure 34 shows the state transition.

(1) Identification of the start condition

Warm start (return from the RAM back-up state) or cold start (return from the normal reset state) can be identified by examining the state of the power down flag (P) with the SNZP instruction.

(2) Warm start condition

When the external wakeup signal is input after the system enters the RAM back-up state by executing the EPOF and POF instructions continuously, the CPU starts executing the program from address 0 in page 0. In this case, the P flag is "1."

(3) Cold start condition

The CPU starts executing the program from address 0 in page 0 when;

- reset pulse is input to $\overline{\text{RESET}}$ pin, or
- reset by watchdog timer is performed, or

In this case, the P flag is "0."

Table 18 Functions and states retained at RAM back-up

Function	RAM back-up
Program counter (PC), registers A, B, carry flag (CY), stack pointer (SP) (Note 2)	X
Contents of RAM	O
Port level	O
Timer control register W1	X
Timer control registers W2 to W4	O
Clock control register MR	X
Interrupt control registers V1, V2	X
Interrupt control registers I1, I2	O
Timer 1 function	X
Timer 2 function	(Note 3)
Timer 3 function	(Note 3)
Timer 4 function	(Note 3)
A-D conversion function	X
A-D control registers Q1, Q2	O
Serial I/O function	X
Serial I/O mode register J1	O
Pull-up control register PU0	O
Key-on wakeup control register K0	O
External 0 interrupt request flag (EXF0)	X
External 1 interrupt request flag (EXF1)	X
Timer 1 interrupt request flag (T1F)	X
Timer 2 interrupt request flag (T2F)	(Note 3)
Timer 3 interrupt request flag (T3F)	(Note 3)
Timer 4 interrupt request flag (T4F)	(Note 3)
Watchdog timer flags (WDF1, WDF2)	X (Note 4)
Watchdog timer enable flag (WEF)	X (Note 4)
16-bit timer (WDT)	X (Note 4)
A-D conversion completion flag (ADF)	X
Serial I/O transmission/reception completion flag (SIOF)	X
Interrupt enable flag (INTE)	X

Notes 1: "O" represents that the function can be retained, and "X" represents that the function is initialized.

Registers and flags other than the above are undefined at RAM back-up, and set an initial value after returning.

2: The stack pointer (SP) points the level of the stack register and is initialized to "7" at RAM back-up.

3: The state of the timer is undefined.

4: Initialize the watchdog timer with the WRST instruction, and then execute the POF instruction.

PRELIMINARY
 Notice: This is not a final specification.
 Some parametric limits are subject to change.

(4) Return signal

An external wakeup signal is used to return from the RAM back-up mode because the oscillation is stopped. Table 19 shows the return condition for each return source.

(5) Ports P0 and P1 control registers

- Key-on wakeup control register K0
 Register K0 controls the ports P0 and P1 key-on wakeup function. Set the contents of this register through register A with the TK0A instruction. In addition, the TAK0 instruction can be used to transfer the contents of register K0 to register A.
- Pull-up control register PU0
 Register PU0 controls the ON/OFF of the ports P0 and P1 pull-up transistor. Set the contents of this register through register A with the TPU0A instruction. In addition, the TAPU0 instruction can be used to transfer the contents of register PU0 to register A.

Table 19 Return source and return condition

Return source	Return condition	Remarks
External wakeup signal	Ports P0, P1	Return by an external falling edge input ("H"→"L"). Set the port using the key-on wakeup function selected with register K0 to "H" level before going into the RAM back-up state because the port P0 shares the falling edge detection circuit with port P1.
	INT0 pin	Return by an external "H" level or "L" level input. The EXF0 flag is not set. Select the return level ("L" level or "H" level) with the bit 2 of register I1 according to the external state before going into the RAM back-up state.
	INT1 pin	Return by an external "H" level or "L" level input. The EXF1 flag is not set. Select the return level ("L" level or "H" level) with the bit 2 of register I2 according to the external state before going into the RAM back-up state.

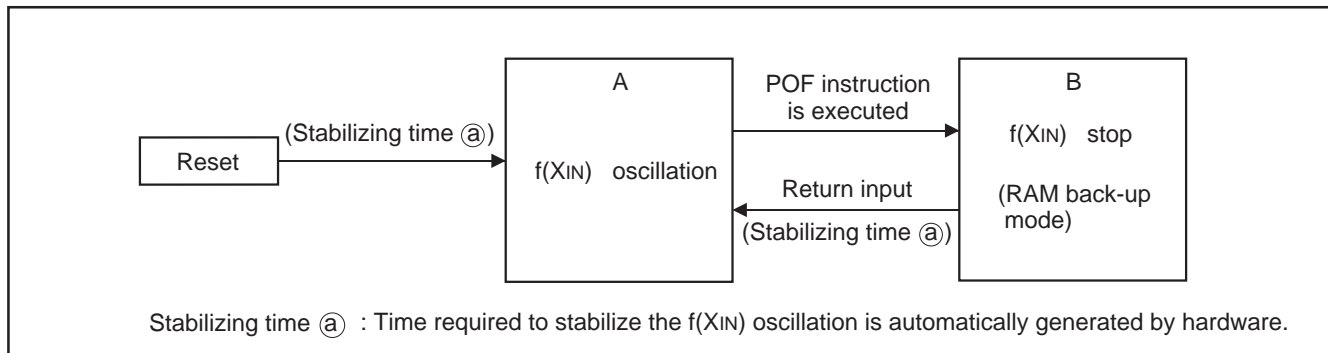

Fig. 34 State transition

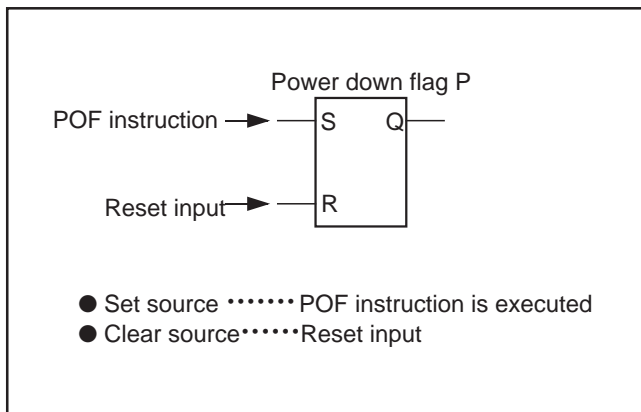

Fig. 35 Set source and clear source of the P flag

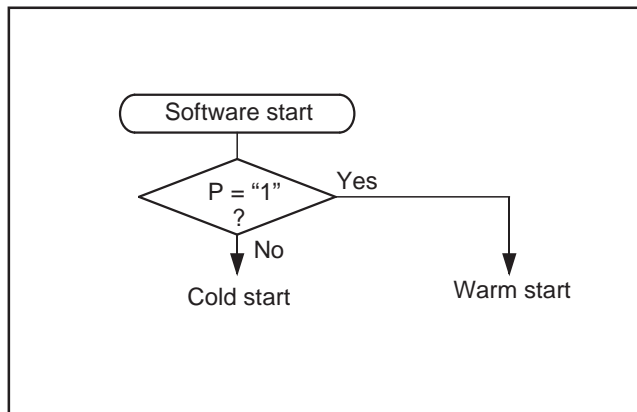

Fig. 36 Start condition identified example using the SNZP instruction

PRELIMINARY
 Notice: This is not a final specification.
 Some parametric limits are subject to
 change.

Table 20 Key-on wakeup control register, pull-up control register, and interrupt control register

Key-on wakeup control register K0		at reset : 00002	at RAM back-up : state retained	R/W
K03	Pins P12 and P13 key-on wakeup control bit	0	Key-on wakeup not used	
		1	Key-on wakeup used	
K02	Pins P10 and P11 key-on wakeup control bit	0	Key-on wakeup not used	
		1	Key-on wakeup used	
K01	Pins P02 and P03 key-on wakeup control bit	0	Key-on wakeup not used	
		1	Key-on wakeup used	
K00	Pins P00 and P01 key-on wakeup control bit	0	Key-on wakeup not used	
		1	Key-on wakeup used	
Pull-up control register PU0		at reset : 00002	at RAM back-up : state retained	R/W
PU03	Pins P12 and P13 pull-up transistor control bit	0	Pull-up transistor OFF	
		1	Pull-up transistor ON	
PU02	Pins P10 and P11 pull-up transistor control bit	0	Pull-up transistor OFF	
		1	Pull-up transistor ON	
PU01	Pins P02 and P03 pull-up transistor control bit	0	Pull-up transistor OFF	
		1	Pull-up transistor ON	
PU00	Pins P00 and P01 pull-up transistor control bit	0	Pull-up transistor OFF	
		1	Pull-up transistor ON	
Interrupt control register I1		at reset : 00002	at RAM back-up : state retained	R/W
I13	Not used	0	This bit has no function, but read/write is enabled.	
		1		
I12	Interrupt valid waveform for INT0 pin/ return level selection bit (Note 2)	0	Falling waveform ("L" level of INT0 pin is recognized with the SNZI0 instruction)/"L" level	
		1	Rising waveform ("H" level of INT0 pin is recognized with the SNZI0 instruction)/"H" level	
I11	INT0 pin edge detection circuit control bit	0	One-sided edge detected	
		1	Both edges detected	
I10	INT0 pin timer 1 control enable bit	0	Disabled	
		1	Enabled	
Interrupt control register I2		at reset : 00002	at RAM back-up : state retained	R/W
I23	Not used	0	This bit has no function, but read/write is enabled.	
		1		
I22	Interrupt valid waveform for INT1 pin/ return level selection bit (Note 3)	0	Falling waveform ("L" level of INT1 pin is recognized with the SNZI1 instruction)/"L" level	
		1	Rising waveform ("H" level of INT1 pin is recognized with the SNZI1 instruction)/"H" level	
I21	INT1 pin edge detection circuit control bit	0	One-sided edge detected	
		1	Both edges detected	
I20	INT1 pin timer 3 control enable bit	0	Disabled	
		1	Enabled	

Notes 1: "R" represents read enabled, and "W" represents write enabled.

2: When the contents of I12 is changed, the external interrupt request flag EXF0 may be set. Accordingly, clear EXF0 flag with the SNZ0 instruction.

3: When the contents of I22 is changed, the external interrupt request flag EXF1 may be set. Accordingly, clear EXF1 flag with the SNZ1 instruction.

PRELIMINARY
 Notice: This is not a final specification.
 Some parametric limits are subject to change.

CLOCK CONTROL

The clock control circuit consists of the following circuits.

- System clock generating circuit
- Control circuit to stop the clock oscillation
- Control circuit to switch the middle-speed mode and high-speed mode
- Control circuit to return from the RAM back-up state

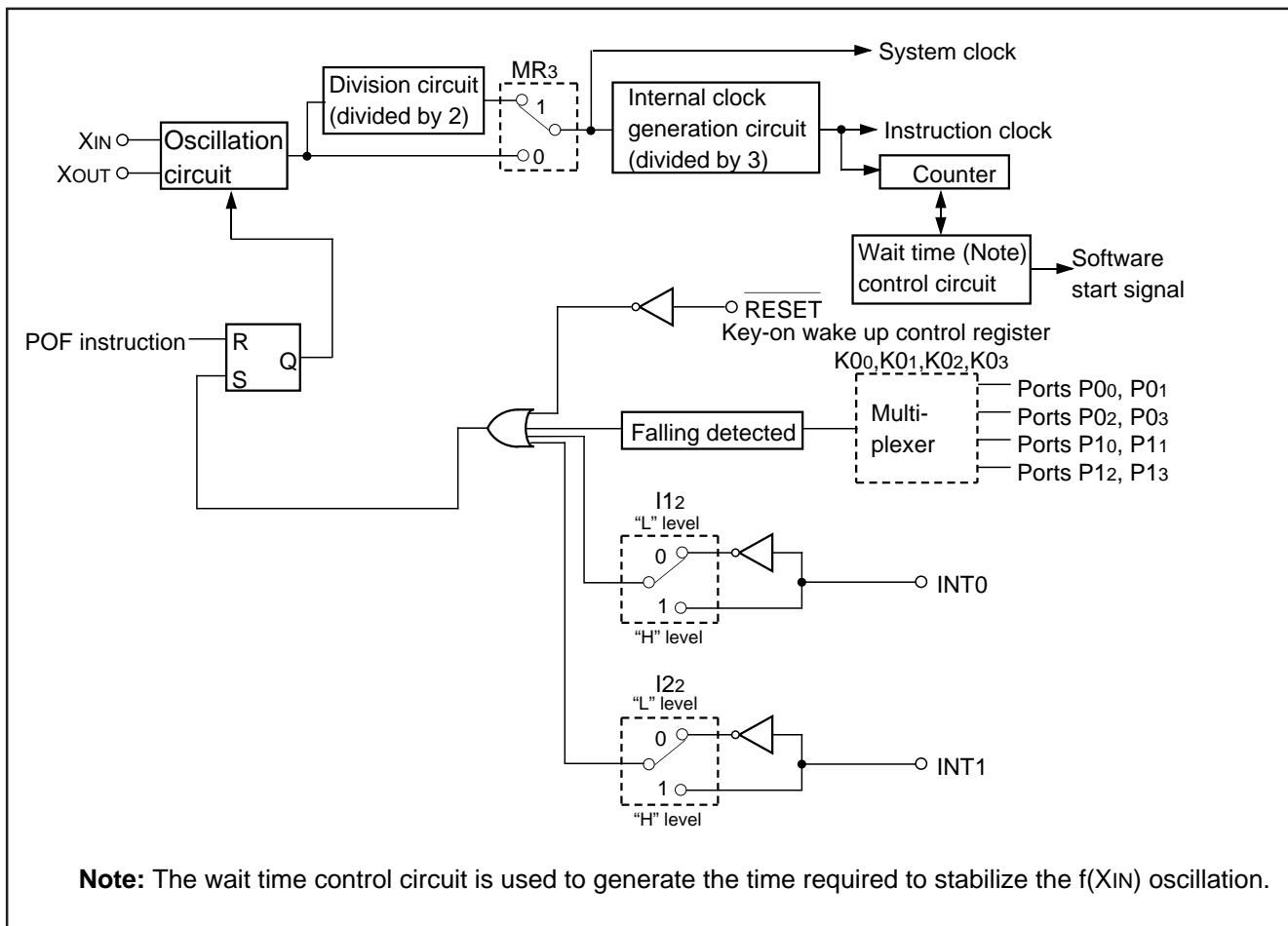

Fig. 37 Clock control circuit structure

(1) Clock control register

Register MR controls system clock. Set the contents of this register through register A with the TMRA instruction. In addition, the TAMR instruction can be used to transfer the contents of register MR to register A.

Table 23 Clock control register MR

Clock control register MR		at reset : 10002		at RAM back-up : 10002	R/W
MR3	System clock selection bit	0	f(XIN) (high-speed mode)		
		1	f(XIN)/2 (middle-speed mode)		
MR2	Not used	0	This bit has no function, but read/write is enabled.		
		1			
MR1	Not used	0	This bit has no function, but read/write is enabled.		
		1			
MR0	Not used	0	This bit has no function, but read/write is enabled.		
		1			

Note : "R" represents read enabled, and "W" represents write enabled.

PRELIMINARY
 Notice: This is not a final specification.
 Some parametric limits are subject to change.

Clock signal $f(X_{IN})$ is obtained by externally connecting a ceramic resonator.

Connect this external circuit to pins X_{IN} and X_{OUT} at the shortest distance. A feedback resistor is built in between pins X_{IN} and X_{OUT} . When an external clock signal is input, connect the clock source to X_{IN} and leave X_{OUT} open. When using an external clock, the maximum value of external clock oscillating frequency is shown in Table 22.

Table 22 Maximum value of external clock oscillation frequency

Supply voltage	Oscillation frequency (duty ratio)
$V_{DD} = 4.0\text{ V to }5.5\text{ V}$	3.0 MHz (40 % to 60 %)

ROM ORDERING METHOD

Please submit the information described below when ordering Mask ROM.

- (1) Mask ROM Order Confirmation Form 1
- (2) Data to be written into mask ROM EPROM
 (three sets containing the identical data)
- (3) Mark Specification Form 1

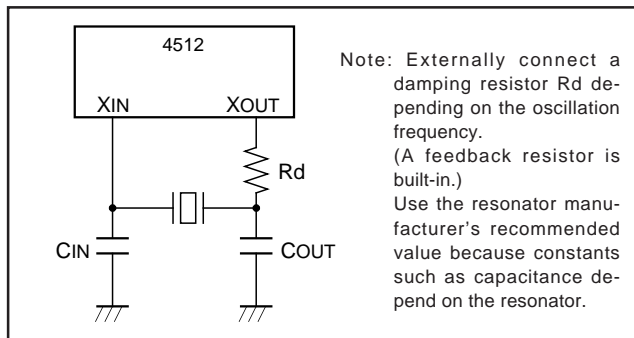

Fig. 38 Ceramic resonator external circuit

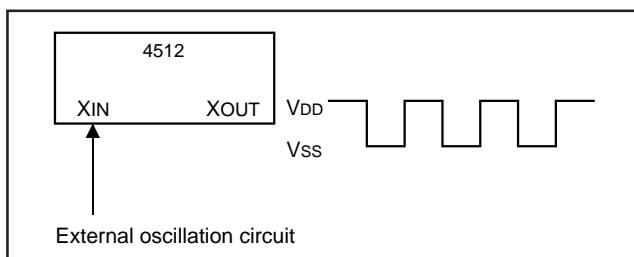

Fig. 39 External clock input circuit

PRELIMINARY
 Notice: This is not a final specification.
 Some parametric limits are subject to change.

Differences from 4513 Group

The 4512 Group has pin-compatibility with the 4513 Group, but its function and recommended operating condition are different from the 4513 Group. The differences are as follows:

Parameter		4513 Group	4512 Group
Hardware	Basic instructions	123	117 (Note 2)
	Voltage drop detection circuit	O	X
	Voltage comparator	O	X
	Timer I/O (CNTR0, CNTR1)	O	X
	Ports P30, P31	O	X
	Timer control register W6	O	X
	Voltage comparator control register W6	O	X
Recommended operating condition	Supply voltage	2.5 V to 5.5 V	4.0 V to 5.5 V
		2.0 V to 5.5 V	
		4.0 V to 5.5 V	
		2.5 V to 5.5 V	
		2.0 V to 5.5 V	
Others	Large size memory version supported	O (M34513M6/M8/E8)	X
	DIP package supported	O (M34513M2/M4/E4)	X
	One Time PROM version supported	O (M34513E4/E8)	X (M34513E4 can be used)

Notes 1: "O" represents that the function is supported, "X" represents that the function is not supported.

2: For the 4512 Group, TQ3A, TAQ3, TW6A, TAW6, OP3A and IAP3 instructions cannot be used.

PIN CONFIGURATIONS

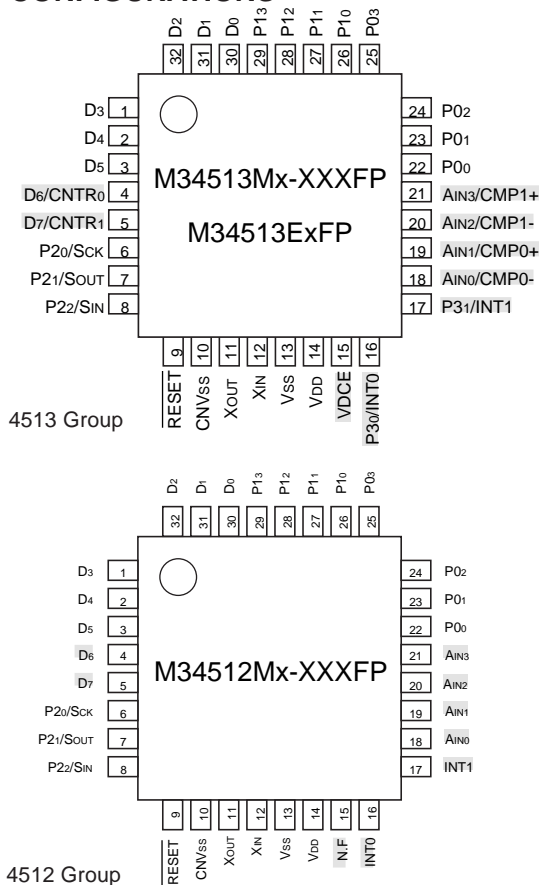

4513 Group	Pin number	4512 Group
D3	1	D3
D4	2	D4
D5	3	D5
D6/CNTR0	4	D6
D7/CNTR1	5	D7
P20/Sck	6	P20/Sck
P21/SOUT	7	P21/SOUT
P22/SIN	8	P22/SIN
RESET	9	RESET
CNVss	10	CNVss
XOUT	11	XOUT
XIN	12	XIN
Vss	13	Vss
VDD	14	VDD
VDCE	15	N.F
P30/INT0	16	INT0
P31/INT1	17	INT1
AIN0/CMP0-	18	AIN0
AIN1/CMP0+	19	AIN1
AIN2/CMP1-	20	AIN2
AIN3/CMP1+	21	AIN3
P00	22	P00
P01	23	P01
P02	24	P02
P03	25	P03
P10	26	P10
P11	27	P11
P12	28	P12
P13	29	P13
D0	30	D0
D1	31	D1
D2	32	D2

PRELIMINARY
 Notice: This is not a final specification.
 Some parametric limits are subject to change.

LIST OF PRECAUTIONS

① **Noise and latch-up prevention**

Connect a capacitor on the following condition to prevent noise and latch-up;

- connect a bypass capacitor (approx. 0.1 μF) between pins VDD and VSS at the shortest distance,
- equalize its wiring in width and length, and
- use relatively thick wire.

② **Prescaler**

Stop the prescaler operation to change its frequency dividing ratio.

③ **Timer count source**

Stop timer 1, 2, 3, or 4 counting to change its count source.

④ **Reading the count value**

Stop timer 1, 2, 3, or 4 counting and then execute the TAB1, TAB2, TAB3, or TAB4 instruction to read its data.

⑤ **Writing to reload registers R1 and R3**

When writing data to reload registers R1 or R3 while timer 1 or timer 3 is operating, avoid a timing when timer 1 or timer 3 underflows.

⑥ **INT0 pin**

When the interrupt valid waveform of the INT0 pin is changed with the bit 2 of register I1 in software, be careful about the following notes.

- Clear the bit 0 of register V1 to "0" before the interrupt valid waveform of INT0 pin is changed with the bit 2 of register I1 (refer to Figure 40①).
- Depending on the input state of the INT0 pin, the external 0 interrupt request flag (EXF0) may be set when the interrupt valid waveform is changed. Accordingly, clear bit 2 of register I1, and execute the SNZ0 instruction to clear the EXF0 flag after executing at least one instruction (refer to Figure 40②)

```

:
LA 4 ; (XXX02)
TV1A ; The SNZ0 instruction is valid .....①
LA 4 ;
TI1A ; Interrupt valid waveform is changed
NOP ..... ②
SNZ0 ; The SNZ0 instruction is executed
NOP
:
X : this bit is not related to the setting of INT0 pin.
```

Fig. 40 External 0 interrupt program example

⑦ **INT1 pin**

When the interrupt valid waveform of INT1 pin is changed with the bit 2 of register I2 in software, be careful about the following notes.

- Clear the bit 1 of register V1 to "0" before the interrupt valid waveform of INT1 pin is changed with the bit 2 of register I2 (refer to Figure 41③).
- Depending on the input state of the INT1 pin, the external 1 interrupt request flag (EXF1) may be set when the interrupt valid waveform is changed. Accordingly, clear bit 2 of register I2 and execute the SNZ1 instruction to clear the EXF1 flag after executing at least one instruction (refer to Figure 41④).

```

:
LA 8 ; (XX0X2)
TV1A ; The SNZ1 instruction is valid .....③
LA 8 ;
TI2A ; Change of the interrupt valid waveform
NOP ..... ④
SNZ1 ; The SNZ1 instruction is executed
NOP
:
X : this bit is not related to the setting of INT1.
```

Fig. 41 External 1 interrupt program example

⑧ **Multifunction**

The input of P20-P22 can be used even when SCK, SOUT, SIN are selected.

PRELIMINARY
 Notice: This is not a final specification.
 Some parametric limits are subject to
 change.

⑨ A-D converter-1

When the operating mode of the A-D converter is changed from the comparator mode to the A-D conversion mode with the bit 3 of register Q2 in a program, be careful about the following notes.

- Clear the bit 2 of register V2 to "0" to change the operating mode of the A-D converter from the comparator mode to the A-D conversion mode with the bit 3 of register Q2 (refer to Figure 42⑤).
- The A-D conversion completion flag (ADF) may be set when the operating mode of the A-D converter is changed from the comparator mode to the A-D conversion mode. Accordingly, set a value to register Q2, and execute the SNZAD instruction to clear the ADF flag.

Do not change the operating mode (both A-D conversion mode and comparator mode) of A-D converter with the bit 3 of register Q2 during operating the A-D converter.

```

:
LA 8 ; (X0XX2)
TV2A ; The SNZAD instruction is valid .....⑤
LA 0 ; (0XXX2)
TQ2A ; Change of the operating mode of the A-D
      ; converter from the comparator mode to the
      ; A-D conversion mode

SNZAD
NOP
:
X: this bit is not related to the change of the
   operating mode of the A-D conversion.
    
```

Fig. 42 A-D converter operating mode program example

⑩ A-D converter-2

Each analog input pin is equipped with a capacitor which is used to compare the analog voltage. Accordingly, when the analog voltage is input from the circuit with high-impedance and, charge/discharge noise is generated and the sufficient A-D accuracy may not be obtained. Therefore, reduce the impedance or, connect a capacitor (0.01 μF to 1 μF) to analog input pins (Figure 43).

When the overvoltage applied to the A-D conversion circuit may occur, connect an external circuit in order to keep the voltage within the rated range as shown the Figure 44. In addition, test the application products sufficiently.

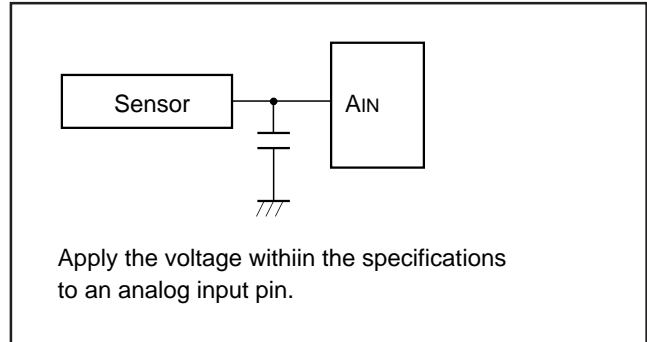

Apply the voltage within the specifications to an analog input pin.

Fig. 43 Analog input external circuit example-1

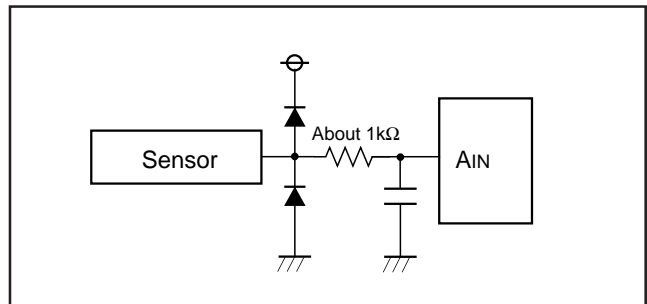

Fig. 44 Analog input external circuit example-2

⑪ POF instruction

Execute the POF instruction immediately after executing the EPOF instruction to enter the RAM back-up.

Note that system cannot enter the RAM back-up state when executing only the POF instruction.

Be sure to disable interrupts by executing the DI instruction before executing the EPOF instruction.

⑫ TALA instruction

When the TALA instruction is executed, the low-order 2 bits of register AD is transferred to the high-order 2 bits of register A, simultaneously, the low-order 2 bits of register A is "0."

⑬ Program counter

Make sure that the PCH does not specify after the last page of the built-in ROM.

⑭ N.F pin

This pin has no function, and connect to VSS as an unused pin.

PRELIMINARY
 Notice: This is not a final specification.
 Some parametric limits are subject to
 change.

CONTROL REGISTERS

Interrupt control register V1		at reset : 0000 ₂	at RAM back-up : 0000 ₂	R/W
V13	Timer 2 interrupt enable bit	0	Interrupt disabled (SNZT2 instruction is valid)	
		1	Interrupt enabled (SNZT2 instruction is invalid)	
V12	Timer 1 interrupt enable bit	0	Interrupt disabled (SNZT1 instruction is valid)	
		1	Interrupt enabled (SNZT1 instruction is invalid)	
V11	External 1 interrupt enable bit	0	Interrupt disabled (SNZ1 instruction is valid)	
		1	Interrupt enabled (SNZ1 instruction is invalid)	
V10	External 0 interrupt enable bit	0	Interrupt disabled (SNZ0 instruction is valid)	
		1	Interrupt enabled (SNZ0 instruction is invalid)	
Interrupt control register V2		at reset : 0000 ₂	at RAM back-up : 0000 ₂	R/W
V23	Serial I/O interrupt enable bit	0	Interrupt disabled (SNZSI instruction is valid)	
		1	Interrupt enabled (SNZSI instruction is invalid)	
V22	A-D interrupt enable bit	0	Interrupt disabled (SNZAD instruction is valid)	
		1	Interrupt enabled (SNZAD instruction is invalid)	
V21	Timer 4 interrupt enable bit	0	Interrupt disabled (SNZT4 instruction is valid)	
		1	Interrupt enabled (SNZT4 instruction is invalid)	
V20	Timer 3 interrupt enable bit	0	Interrupt disabled (SNZT3 instruction is valid)	
		1	Interrupt enabled (SNZT3 instruction is invalid)	
Interrupt control register I1		at reset : 0000 ₂	at RAM back-up : state retained	R/W
I13	Not used	0	This bit has no function, but read/write is enabled.	
		1		
I12	Interrupt valid waveform for INT0 pin/ return level selection bit (Note 2)	0	Falling waveform ("L" level of INT0 pin is recognized with the SNZIO instruction)/"L" level	
		1	Rising waveform ("H" level of INT0 pin is recognized with the SNZIO instruction)/"H" level	
I11	INT0 pin edge detection circuit control bit	0	One-sided edge detected	
		1	Both edges detected	
I10	INT0 pin timer 1 control enable bit	0	Disabled	
		1	Enabled	
Interrupt control register I2		at reset : 0000 ₂	at RAM back-up : state retained	R/W
I23	Not used	0	This bit has no function, but read/write is enabled.	
		1		
I22	Interrupt valid waveform for INT1 pin/ return level selection bit (Note 3)	0	Falling waveform ("L" level of INT1 pin is recognized with the SNZI1 instruction)/"L" level	
		1	Rising waveform ("H" level of INT1 pin is recognized with the SNZI1 instruction)/"H" level	
I21	INT1 pin edge detection circuit control bit	0	One-sided edge detected	
		1	Both edges detected	
I20	INT1 pin timer 3 control enable bit	0	Disabled	
		1	Enabled	

Notes 1: "R" represents read enabled, and "W" represents write enabled.

2: When the contents of I12 is changed, the external interrupt request flag EXF0 may be set. Accordingly, clear EXF0 flag with the SNZ0 instruction.

3: When the contents of I22 is changed, the external interrupt request flag EXF1 may be set. Accordingly, clear EXF1 flag with the SNZ1 instruction.

PRELIMINARY
 Notice: This is not a final specification.
 Some parametric limits are subject to change.

CONTROL REGISTERS (continued)

Timer control register W1		at reset : 0000 ₂		at RAM back-up : 0000 ₂		R/W
W13	Prescaler control bit	0	Stop (state initialized)			
		1	Operating			
W12	Prescaler dividing ratio selection bit	0	Instruction clock divided by 4			
		1	Instruction clock divided by 16			
W11	Timer 1 control bit	0	Stop (state retained)			
		1	Operating			
W10	Timer 1 count start synchronous circuit control bit	0	Count start synchronous circuit not selected			
		1	Count start synchronous circuit selected			
Timer control register W2		at reset : 0000 ₂		at RAM back-up : state retained		R/W
W23	Timer 2 control bit	0	Stop (state retained)			
		1	Operating			
W22	Not used	0	This bit has no function, but read/write is enabled.			
		1				
W21	Timer 2 count source selection bits	W21 W20		Count source		
		0	0	Timer 1 underflow signal		
0		1	Prescaler output			
W20		1	0	Not available		
	1	1	16 bit timer (WDT) underflow signal			
Timer control register W3		at reset : 0000 ₂		at RAM back-up : state retained		R/W
W33	Timer 3 control bit	0	Stop (state retained)			
		1	Operating			
W32	Timer 3 count start synchronous circuit control bit	0	Count start synchronous circuit not selected			
		1	Count start synchronous circuit selected			
W31	Timer 3 count source selection bits	W31 W30		Count source		
		0	0	Timer 2 underflow signal		
0		1	Prescaler output			
W30		1	0	Not available		
	1	1	Not available			
Timer control register W4		at reset : 0000 ₂		at RAM back-up : state retained		R/W
W43	Timer 4 control bit	0	Stop (state retained)			
		1	Operating			
W42	Not used	0	This bit has no function, but read/write is enabled.			
		1				
W41	Timer 4 count source selection bits	W41 W40		Count source		
		0	0	Timer 3 underflow signal		
0		1	Prescaler output			
W40		1	0	Not available		
	1	1	Not available			

Note: "R" represents read enabled, and "W" represents write enabled.

PRELIMINARY
 Notice: This is not a final specification.
 Some parametric limits are subject to
 change.

CONTROL REGISTERS (continued)

Serial I/O mode register J1		at reset : 00002		at RAM back-up : state retained	R/W	
J13	Not used	0	This bit has no function, but read/write is enabled.			
		1				
J12	Serial I/O internal clock dividing ratio selection bit	0	Instruction clock signal divided by 8			
		1	Instruction clock signal divided by 4			
J11	Serial I/O port selection bit	0	Input ports P20, P21, P22 selected			
		1	Serial I/O ports SCK, SOUT, SIN/input ports P20, P21, P22 selected			
J10	Serial I/O synchronous clock selection bit	0	External clock			
		1	Internal clock (instruction clock divided by 4 or 8)			
A-D control register Q1		at reset : 00002		at RAM back-up : state retained	R/W	
Q13	Not used	0	This bit has no function, but read/write is enabled.			
		1				
Q12	Analog input pin selection bits	Selected pins				
		Q12	Q11	Q10		AIN0
0		0	1	AIN1		
Q11		0	1	0		AIN2
		0	1	1		AIN3
Q10		1	0	0		Not available
		1	0	1		Not available
		1	1	0		Not available
		1	1	1		Not available
A-D control register Q2		at reset : 00002		at RAM back-up : state retained		R/W
Q23	A-D operation mode selection bit	0	A-D conversion mode			
		1	Comparator mode			
Q22	Not used	0	This bit has no function, but read/write is enabled.			
		1				
Q21	Not used	0	This bit has no function, but read/write is enabled.			
		1				
Q20	Not used	0	This bit has no function, but read/write is enabled.			
		1				

Note: "R" represents read enabled, and "W" represents write enabled.

PRELIMINARY
 Notice: This is not a final specification.
 Some parametric limits are subject to
 change.

CONTROL REGISTERS (continued)

Key-on wakeup control register K0		at reset : 00002		at RAM back-up : state retained	R/W
K03	Pins P12 and P13 key-on wakeup control bit	0	Key-on wakeup not used		
		1	Key-on wakeup used		
K02	Pins P10 and P11 key-on wakeup control bit	0	Key-on wakeup not used		
		1	Key-on wakeup used		
K01	Pins P02 and P03 key-on wakeup control bit	0	Key-on wakeup not used		
		1	Key-on wakeup used		
K00	Pins P00 and P01 key-on wakeup control bit	0	Key-on wakeup not used		
		1	Key-on wakeup used		
Pull-up control register PU0		at reset : 00002		at RAM back-up : state retained	R/W
PU03	Pins P12 and P13 pull-up transistor control bit	0	Pull-up transistor OFF		
		1	Pull-up transistor ON		
PU02	Pins P10 and P11 pull-up transistor control bit	0	Pull-up transistor OFF		
		1	Pull-up transistor ON		
PU01	Pins P02 and P03 pull-up transistor control bit	0	Pull-up transistor OFF		
		1	Pull-up transistor ON		
PU00	Pins P00 and P01 pull-up transistor control bit	0	Pull-up transistor OFF		
		1	Pull-up transistor ON		
Clock control register MR		at reset : 10002		at RAM back-up : 10002	R/W
MR3	System clock selection bit	0	f(XIN) (high-speed mode)		
		1	f(XIN)/2 (middle-speed mode)		
MR2	Not used	0	This bit has no function, but read/write is enabled.		
		1			
MR1	Not used	0	This bit has no function, but read/write is enabled.		
		1			
MR0	Not used	0	This bit has no function, but read/write is enabled.		
		1			

Note : "R" represents read enabled, and "W" represents write enabled.

PRELIMINARY
 Notice: This is not a final specification.
 Some parametric limits are subject to
 change.

SYMBOL

The symbols shown below are used in the following instruction function table and instruction list.

Symbol	Contents	Symbol	Contents
A	Register A (4 bits)	T1F	Timer 1 interrupt request flag
B	Register B (4 bits)	T2F	Timer 2 interrupt request flag
DR	Register D (3 bits)	T3F	Timer 3 interrupt request flag
E	Register E (8 bits)	T4F	Timer 4 interrupt request flag
Q1	A-D control register Q1 (4 bits)	WDF1, WDF2	Watchdog timer flag
Q2	A-D control register Q2 (4 bits)	WEF	Watchdog timer enable flag
AD	Successive comparison register AD (10 bits)	INTE	Interrupt enable flag
J1	Serial I/O mode register J1 (4 bits)	EXF0	External 0 interrupt request flag
SI	Serial I/O register SI (8 bits)	EXF1	External 1 interrupt request flag
V1	Interrupt control register V1 (4 bits)	P	Power down flag
V2	Interrupt control register V2 (4 bits)	ADF	A-D conversion completion flag
I1	Interrupt control register I1 (4 bits)	SIOF	Serial I/O transmission/reception completion flag
I2	Interrupt control register I2 (4 bits)		
W1	Timer control register W1 (4 bits)	D	Port D (8 bits)
W2	Timer control register W2 (4 bits)	P0	Port P0 (4 bits)
W3	Timer control register W3 (4 bits)	P1	Port P1 (4 bits)
W4	Timer control register W4 (4 bits)	P2	Port P2 (3 bits)
MR	Clock control register MR (4 bits)		
K0	Key-on wakeup control register K0 (4 bits)	x	Hexadecimal variable
PU0	Pull-up control register PU0 (4 bits)	y	Hexadecimal variable
X	Register X (4 bits)	z	Hexadecimal variable
Y	Register Y (4 bits)	p	Hexadecimal variable
Z	Register Z (2 bits)	n	Hexadecimal constant
DP	Data pointer (10 bits) (It consists of registers X, Y, and Z)	i	Hexadecimal constant
PC	Program counter (14 bits)	j	Hexadecimal constant
PC _H	High-order 7 bits of program counter	A3A2A1A0	Binary notation of hexadecimal variable A (same for others)
PC _L	Low-order 7 bits of program counter		
SK	Stack register (14 bits X 8)	←	Direction of data movement
SP	Stack pointer (3 bits)	↔	Data exchange between a register and memory
CY	Carry flag	?	Decision of state shown before “?”
R1	Timer 1 reload register	()	Contents of registers and memories
R2	Timer 2 reload register	—	Negate, Flag unchanged after executing instruction
R3	Timer 3 reload register	M(DP)	RAM address pointed by the data pointer
R4	Timer 4 reload register	a	Label indicating address a6 a5 a4 a3 a2 a1 a0
T1	Timer 1	p, a	Label indicating address a6 a5 a4 a3 a2 a1 a0 in page p5 p4 p3 p2 p1 p0
T2	Timer 2	C	Hex. C + Hex. number x (also same for others)
T3	Timer 3	+	
T4	Timer 4	x	

Note : The 4512 Group just invalidates the next instruction when a skip is performed. The contents of program counter is not increased by 2. Accordingly, the number of cycles does not change even if skip is not performed. However, the cycle count becomes “1” if the TABP p, RT, or RTS instruction is skipped.

PRELIMINARY
 Notice: This is not a final specification.
 Some parametric limits are subject to
 change.

LIST OF INSTRUCTION FUNCTION

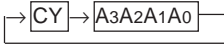
Grouping	Mnemonic	Function	Grouping	Mnemonic	Function	Grouping	Mnemonic	Function	
Register to register transfer	TAB	$(A) \leftarrow (B)$	RAM to register transfer	XAMI j	$(A) \leftarrow (M(DP))$ $(X) \leftarrow (X)EXOR(j)$ $j = 0 \text{ to } 15$ $(Y) \leftarrow (Y) + 1$	Bit operation	SB j	$(Mj(DP)) \leftarrow 1$ $j = 0 \text{ to } 3$	
	TBA	$(B) \leftarrow (A)$		TMA j	$(M(DP)) \leftarrow (A)$ $(X) \leftarrow (X)EXOR(j)$ $j = 0 \text{ to } 15$		RB j	$(Mj(DP)) \leftarrow 0$ $j = 0 \text{ to } 3$	
	TAY	$(A) \leftarrow (Y)$		Arithmetic operation	LA n		$(A) \leftarrow n$ $n = 0 \text{ to } 15$	Comparison operation	SEAM
	TYA	$(Y) \leftarrow (A)$			TABP p	$(SP) \leftarrow (SP) + 1$ $(SK(SP)) \leftarrow (PC)$ $(PCH) \leftarrow p$ $(PCL) \leftarrow (DR2-DR0,$ $A3-A0)$ $(B) \leftarrow (ROM(PC))7-4$ $(A) \leftarrow (ROM(PC))3-0$ $(PC) \leftarrow (SK(SP))$ $(SP) \leftarrow (SP) - 1$	SEA n		$(A) = n ?$ $n = 0 \text{ to } 15$
	TEAB	$(E7-E4) \leftarrow (B)$ $(E3-E0) \leftarrow (A)$			AM	$(A) \leftarrow (A) + (M(DP))$	Branch operation	B a	$(PCL) \leftarrow a6-a0$
	TABE	$(B) \leftarrow (E7-E4)$ $(A) \leftarrow (E3-E0)$			AMC	$(A) \leftarrow (A) + (M(DP)) +$ (CY) $(CY) \leftarrow \text{Carry}$		BL p, a	$(PCH) \leftarrow p$ $(PCL) \leftarrow a6-a0$
	TDA	$(DR2-DR0) \leftarrow (A2-A0)$			A n	$(A) \leftarrow (A) + n$ $n = 0 \text{ to } 15$		BLA p	$(PCH) \leftarrow p$ $(PCL) \leftarrow (DR2-DR0,$ $A3-A0)$
	TAD	$(A2-A0) \leftarrow (DR2-DR0)$ $(A3) \leftarrow 0$			AND	$(A) \leftarrow (A) \text{ AND } (M(DP))$	Subroutine operation	BM a	$(SP) \leftarrow (SP) + 1$ $(SK(SP)) \leftarrow (PC)$ $(PCH) \leftarrow 2$ $(PCL) \leftarrow a6-a0$
	TAZ	$(A1, A0) \leftarrow (Z1, Z0)$ $(A3, A2) \leftarrow 0$			OR	$(A) \leftarrow (A) \text{ OR } (M(DP))$		BML p, a	$(SP) \leftarrow (SP) + 1$ $(SK(SP)) \leftarrow (PC)$ $(PCH) \leftarrow p$ $(PCL) \leftarrow a6-a0$
	TAX	$(A) \leftarrow (X)$		SC	$(CY) \leftarrow 1$	BMLA p		$(SP) \leftarrow (SP) + 1$ $(SK(SP)) \leftarrow (PC)$ $(PCH) \leftarrow p$ $(PCL) \leftarrow (DR2-DR0,$ $A3-A0)$	
TASP	$(A2-A0) \leftarrow (SP2-SP0)$ $(A3) \leftarrow 0$	RC	$(CY) \leftarrow 0$	Return operation	RTI	$(PC) \leftarrow (SK(SP))$ $(SP) \leftarrow (SP) - 1$			
RAM addresses	LXY x, y	$(X) \leftarrow x, x = 0 \text{ to } 15$ $(Y) \leftarrow y, y = 0 \text{ to } 15$	SZC		$(CY) = 0 ?$	RT	$(PC) \leftarrow (SK(SP))$ $(SP) \leftarrow (SP) - 1$		
	LZ z	$(Z) \leftarrow z, z = 0 \text{ to } 3$	CMA		$(A) \leftarrow (\bar{A})$	RTS	$(PC) \leftarrow (SK(SP))$ $(SP) \leftarrow (SP) - 1$		
	INY	$(Y) \leftarrow (Y) + 1$	RAR						
	DEY	$(Y) \leftarrow (Y) - 1$							
RAM to register transfer	TAM j	$(A) \leftarrow (M(DP))$ $(X) \leftarrow (X)EXOR(j)$ $j = 0 \text{ to } 15$							
	XAM j	$(A) \leftarrow (M(DP))$ $(X) \leftarrow (X)EXOR(j)$ $j = 0 \text{ to } 15$							
	XAMD j	$(A) \leftarrow (M(DP))$ $(X) \leftarrow (X)EXOR(j)$ $j = 0 \text{ to } 15$ $(Y) \leftarrow (Y) - 1$							

PRELIMINARY
 Notice: This is not a final specification.
 Some parametric limits are subject to
 change.

LIST OF INSTRUCTION FUNCTION (continued)

Group- ing	Mnemonic	Function	Group- ing	Mnemonic	Function	Group- ing	Mnemonic	Function
Interrupt operation	DI	(INTE) ← 0	Timer operation	TAW4	(A) ← (W4)	Timer operation	SNZT1	(T1F) = 1 ? After skipping (T1F) ← 0
	EI	(INTE) ← 1		TW4A	(W4) ← (A)		SNZT2	(T2F) = 1 ? After skipping (T2F) ← 0
	SNZ0	(EXF0) = 1 ? After skipping (EXF0) ← 0		TAB1	(B) ← (T17-T14) (A) ← (T13-T10)		SNZT3	(T3F) = 1 ? After skipping (T3F) ← 0
	SNZ1	(EXF1) = 1 ? After skipping (EXF1) ← 0		T1AB	(R17-R14) ← (B) (T17-T14) ← (B) (R13-R10) ← (A) (T13-T10) ← (A)		SNZT4	(T4F) = 1 ? After skipping (T4F) ← 0
	SNZI0	I12 = 1 : (INT0) = "H" ? I12 = 0 : (INT0) = "L" ?		TAB2	(B) ← (T27-T24) (A) ← (T23-T20)	Input/Output operation	IAP0	(A) ← (P0)
	SNZI1	I22 = 1 : (INT1) = "H" ? I22 = 0 : (INT1) = "L" ?		T2AB	(R27-R24) ← (B) (T27-T24) ← (B) (R23-R20) ← (A) (T23-T20) ← (A)		OP0A	(P0) ← (A)
	TAV1	(A) ← (V1)		TAB3	(B) ← (T37-T34) (A) ← (T33-T30)		IAP1	(A) ← (P1)
	TV1A	(V1) ← (A)		T3AB	(R37-R34) ← (B) (T37-T34) ← (B) (R33-R30) ← (A) (T33-T30) ← (A)		OP1A	(P1) ← (A)
	TAV2	(A) ← (V2)		TAB4	(B) ← (T47-T44) (A) ← (T43-T40)		IAP2	(A2-A0) ← (P22-P20) (A3) ← 0
	TV2A	(V2) ← (A)		T4AB	(R47-R44) ← (B) (T47-T44) ← (B) (R43-R40) ← (A) (T43-T40) ← (A)		CLD	(D) ← 1
	TAI1	(A) ← (I1)		TR1AB	(R17-R14) ← (B) (R13-R10) ← (A)		RD	(D(Y)) ← 0 (Y) = 0 to 7
	TI1A	(I1) ← (A)		TR3AB	(R37-R34) ← (B) (R33-R30) ← (A)		SD	(D(Y)) ← 1 (Y) = 0 to 7
	TAI2	(A) ← (I2)					SZD	(D(Y)) = 0 ? (Y) = 0 to 7
	TI2A	(I2) ← (A)					TK0A	(K0) ← (A)
Timer operation	TAW1	(A) ← (W1)			TAK0	(A) ← (K0)		
	TW1A	(W1) ← (A)			TPU0A	(PU0) ← (A)		
	TAW2	(A) ← (W2)			TAPU0	(A) ← (PU0)		
	TW2A	(W2) ← (A)						
	TAW3	(A) ← (W3)						
	TW3A	(W3) ← (A)						

PRELIMINARY
 Notice: This is not a final specification.
 Some parametric limits are subject to
 change.

LIST OF INSTRUCTION FUNCTION (continued)

Group- ing	Mnemonic	Function	Group- ing	Mnemonic	Function
Serial I/O control operation	TABSI	(A) ← (SI3-SI0) (B) ← (SI7-SI4)	Other operation	NOP	(PC) ← (PC) + 1
	TSIAB	(SI3-SI0) ← (A) (SI7-SI4) ← (B)		POF	RAM back-up
	TAJ1	(A) ← (J1)		EPOF	POF instruction valid
	TJ1A	(J1) ← (A)		SNZP	(P) = 1 ?
	SST	(SIOF) ← 0 Serial I/O starting		WRST	(WDF1) ← 0, (WEF) ← 1
	SNZSI	(SIOF) = 1 ? After skipping (SIOF) ← 0		TAMR	(A) ← (MR)
A-D conversion operation	TABAD	(A) ← (AD5-AD2) (B) ← (AD9-AD6) However, in the com- parator mode, (A) ← (AD3-AD0) (B) ← (AD7-AD4)		TMRA	(MR) ← (A)
	TALA	(A) ← (AD1, AD0, 0, 0)			
	TADAB	(AD3-AD0) ← (A) (AD7-AD4) ← (B)			
	TAQ1	(A) ← (Q1)			
	TQ1A	(Q1) ← (A)			
	ADST	(ADF) ← 0 A-D conversion starting			
	SNZAD	(ADF) = 1 ? After skipping (ADF) ← 0			
	TAQ2	(A) ← (Q2)			
	TQ2A	(Q2) ← (A)			

PRELIMINARY
 Notice: This is not a final specification.
 Some parametric limits are subject to
 change.

INSTRUCTION CODE TABLE

D3-D0	Hex. notation	D9-D4						D5-D0						010000		011000			
		00	01	02	03	04	05	06	07	08	09	0A	0B	0C	0D	0E	0F	10-17	18-1F
0000	0	NOP	BLA	SZB 0	BMLA	-	TASP	A 0	LA 0	TABP 0	TABP 16***	-	-	BML	BML***	BL	BL***	BM	B
0001	1	-	CLD	SZB 1	-	-	TAD	A 1	LA 1	TABP 1	TABP 17***	-	-	BML	BML***	BL	BL***	BM	B
0010	2	POF	-	SZB 2	-	-	TAX	A 2	LA 2	TABP 2	TABP 18***	-	-	BML	BML***	BL	BL***	BM	B
0011	3	SNZP	INY	SZB 3	-	-	TAZ	A 3	LA 3	TABP 3	TABP 19***	-	-	BML	BML***	BL	BL***	BM	B
0100	4	DI	RD	SZD	-	RT	TAV1	A 4	LA 4	TABP 4	TABP 20***	-	-	BML	BML***	BL	BL***	BM	B
0101	5	EI	SD	SEAn	-	RTS	TAV2	A 5	LA 5	TABP 5	TABP 21***	-	-	BML	BML***	BL	BL***	BM	B
0110	6	RC	-	SEAM	-	RTI	-	A 6	LA 6	TABP 6	TABP 22***	-	-	BML	BML***	BL	BL***	BM	B
0111	7	SC	DEY	-	-	-	-	A 7	LA 7	TABP 7	TABP 23***	-	-	BML	BML***	BL	BL***	BM	B
1000	8	-	AND	-	SNZ0	LZ 0	-	A 8	LA 8	TABP 8	TABP 24***	-	-	BML	BML***	BL	BL***	BM	B
1001	9	-	OR	TDA	SNZ1	LZ 1	-	A 9	LA 9	TABP 9	TABP 25***	-	-	BML	BML***	BL	BL***	BM	B
1010	A	AM	TEAB	TABE	SNZI0	LZ 2	-	A 10	LA 10	TABP 10	TABP 26***	-	-	BML	BML***	BL	BL***	BM	B
1011	B	AMC	-	-	SNZI1	LZ 3	EPOF	A 11	LA 11	TABP 11	TABP 27***	-	-	BML	BML***	BL	BL***	BM	B
1100	C	TYA	CMA	-	-	RB 0	SB 0	A 12	LA 12	TABP 12	TABP 28***	-	-	BML	BML***	BL	BL***	BM	B
1101	D	-	RAR	-	-	RB 1	SB 1	A 13	LA 13	TABP 13	TABP 29***	-	-	BML	BML***	BL	BL***	BM	B
1110	E	TBA	TAB	-	TV2A	RB 2	SB 2	A 14	LA 14	TABP 14	TABP 30***	-	-	BML	BML***	BL	BL***	BM	B
1111	F	-	TAY	SZC	TV1A	RB 3	SB 3	A 15	LA 15	TABP 15	TABP 31***	-	-	BML	BML***	BL	BL***	BM	B

The above table shows the relationship between machine language codes and machine language instructions. D3-D0 show the low-order 4 bits of the machine language code, and D9-D4 show the high-order 6 bits of the machine language code. The hexadecimal representation of the code is also provided. There are one-word instructions and two-word instructions, but only the first word of each instruction is shown. Do not use code marked "-."

The codes for the second word of a two-word instruction are described below.

	The second word
BL	10 paaa aaaa
BML	10 paaa aaaa
BLA	10 pp00 pppp
BMLA	10 pp00 pppp
SEA	00 0111 nnnn
SZD	00 0010 1011

• *** cannot be used in the M34512M2-XXXFP.

PRELIMINARY
 Notice: This is not a final specification.
 Some parametric limits are subject to
 change.

INSTRUCTION CODE TABLE (continued)

D ₃ -D ₀	Hex. notation	D ₉ -D ₄	100000	100001	100010	100011	100100	100101	100110	100111	101000	101001	101010	101011	101100	101101	101110	101111	110000
		20	21	22	23	24	25	26	27	28	29	2A	2B	2C	2D	2E	2F	30-3F	
0000	0	-	TW3A	OP0A	T1AB	-	-	IAP0	TAB1	SNZT1	-	WRST	TMA0	TAM0	XAM0	XAMI0	XAMD0	LXY	
0001	1	-	TW4A	OP1A	T2AB	-	-	IAP1	TAB2	SNZT2	-	-	TMA1	TAM1	XAM1	XAMI1	XAMD1	LXY	
0010	2	TJ1A	-	-	T3AB	TAJ1	TAMR	IAP2	TAB3	SNZT3	-	-	TMA2	TAM2	XAM2	XAMI2	XAMD2	LXY	
0011	3	-	-	-	T4AB	-	TAI1	-	TAB4	SNZT4	-	-	TMA3	TAM3	XAM3	XAMI3	XAMD3	LXY	
0100	4	TQ1A	-	-	-	TAQ1	TAI2	-	-	-	-	-	TMA4	TAM4	XAM4	XAMI4	XAMD4	LXY	
0101	5	TQ2A	-	-	-	TAQ2	-	-	-	-	-	-	TMA5	TAM5	XAM5	XAMI5	XAMD5	LXY	
0110	6	-	TMRA	-	-	-	TAK0	-	-	-	-	-	TMA6	TAM6	XAM6	XAMI6	XAMD6	LXY	
0111	7	-	TI1A	-	-	-	TAPU0	-	-	SNZAD	-	-	TMA7	TAM7	XAM7	XAMI7	XAMD7	LXY	
1000	8	-	TI2A	-	TSIAB	-	-	-	TABSI	SNZSI	-	-	TMA8	TAM8	XAM8	XAMI8	XAMD8	LXY	
1001	9	-	-	-	TADAB	TALA	-	-	TABAD	-	-	-	TMA9	TAM9	XAM9	XAMI9	XAMD9	LXY	
1010	A	-	-	-	-	-	-	-	-	-	-	-	TMA10	TAM10	XAM10	XAMI10	XAMD10	LXY	
1011	B	-	TK0A	-	TR3AB	TAW1	-	-	-	-	-	-	TMA11	TAM11	XAM11	XAMI11	XAMD11	LXY	
1100	C	-	-	-	-	TAW2	-	-	-	-	-	-	TMA12	TAM12	XAM12	XAMI12	XAMD12	LXY	
1101	D	-	-	TPU0A	-	TAW3	-	-	-	-	-	-	TMA13	TAM13	XAM13	XAMI13	XAMD13	LXY	
1110	E	TW1A	-	-	-	TAW4	-	-	-	-	SST	-	TMA14	TAM14	XAM14	XAMI14	XAMD14	LXY	
1111	F	TW2A	-	-	TR1AB	-	-	-	-	-	ADST	-	TMA15	TAM15	XAM15	XAMI15	XAMD15	LXY	

The above table shows the relationship between machine language codes and machine language instructions. D₃-D₀ show the low-order 4 bits of the machine language code, and D₉-D₄ show the high-order 6 bits of the machine language code. The hexadecimal representation of the code is also provided. There are one-word instructions and two-word instructions, but only the first word of each instruction is shown. Do not use code marked "-."

The codes for the second word of a two-word instruction are described below.

	The second word	
BL	10	paaa aaaa
BML	10	paaa aaaa
BLA	10	pp00 pppp
BMLA	10	pp00 pppp
SEA	00	0111 nnnn
SZD	00	0010 1011

PRELIMINARY
 Notice: This is not a final specification.
 Some parametric limits are subject to
 change.

MACHINE INSTRUCTIONS

Parameter Type of instructions	Mnemonic	Instruction code											Number of words	Number of cycles	Function
		D9	D8	D7	D6	D5	D4	D3	D2	D1	D0	Hexadecimal notation			
Register to register transfer	TAB	0	0	0	0	0	1	1	1	1	0	0 1 E	1	1	(A) ← (B)
	TBA	0	0	0	0	0	0	1	1	1	0	0 0 E	1	1	(B) ← (A)
	TAY	0	0	0	0	0	1	1	1	1	1	0 1 F	1	1	(A) ← (Y)
	TYA	0	0	0	0	0	0	1	1	0	0	0 0 C	1	1	(Y) ← (A)
	TEAB	0	0	0	0	0	1	1	0	1	0	0 1 A	1	1	(E7-E4) ← (B) (E3-E0) ← (A)
	TABE	0	0	0	0	1	0	1	0	1	0	0 2 A	1	1	(B) ← (E7-E4) (A) ← (E3-E0)
	TDA	0	0	0	0	1	0	1	0	0	1	0 2 9	1	1	(DR2-DR0) ← (A2-A0)
	TAD	0	0	0	1	0	1	0	0	0	1	0 5 1	1	1	(A2-A0) ← (DR2-DR0) (A3) ← 0
	TAZ	0	0	0	1	0	1	0	0	1	1	0 5 3	1	1	(A1, A0) ← (Z1, Z0) (A3, A2) ← 0
	TAX	0	0	0	1	0	1	0	0	1	0	0 5 2	1	1	(A) ← (X)
	TASP	0	0	0	1	0	1	0	0	0	0	0 5 0	1	1	(A2-A0) ← (SP2-SP0) (A3) ← 0
RAM addresses	LXY x, y	1	1	x3	x2	x1	x0	y3	y2	y1	y0	3 x y	1	1	(X) ← x, x = 0 to 15 (Y) ← y, y = 0 to 15
	LZ z	0	0	0	1	0	0	1	0	z1	z0	0 4 8 +z	1	1	(Z) ← z, z = 0 to 3
	INY	0	0	0	0	0	1	0	0	1	1	0 1 3	1	1	(Y) ← (Y) + 1
	DEY	0	0	0	0	0	1	0	1	1	1	0 1 7	1	1	(Y) ← (Y) - 1
RAM to register transfer	TAM j	1	0	1	1	0	0	j	j	j	j	2 C j	1	1	(A) ← (M(DP)) (X) ← (X)EXOR(j) j = 0 to 15
	XAM j	1	0	1	1	0	1	j	j	j	j	2 D j	1	1	(A) ← → (M(DP)) (X) ← (X)EXOR(j) j = 0 to 15
	XAMD j	1	0	1	1	1	1	j	j	j	j	2 F j	1	1	(A) ← → (M(DP)) (X) ← (X)EXOR(j) j = 0 to 15 (Y) ← (Y) - 1
	XAMI j	1	0	1	1	1	0	j	j	j	j	2 E j	1	1	(A) ← → (M(DP)) (X) ← (X)EXOR(j) j = 0 to 15 (Y) ← (Y) + 1
	TMA j	1	0	1	0	1	1	j	j	j	j	2 B j	1	1	(M(DP)) ← (A) (X) ← (X)EXOR(j) j = 0 to 15

PRELIMINARY
 Notice: This is not a final specification.
 Some parametric limits are subject to
 change.

Skip condition	Carry flag CY	Detailed description
-	-	Transfers the contents of register B to register A.
-	-	Transfers the contents of register A to register B.
-	-	Transfers the contents of register Y to register A.
-	-	Transfers the contents of register A to register Y.
-	-	Transfers the contents of registers A and B to register E.
-	-	Transfers the contents of register E to registers A and B.
-	-	Transfers the contents of register A to register D.
-	-	Transfers the contents of register D to register A.
-	-	Transfers the contents of register Z to register A.
-	-	Transfers the contents of register X to register A.
-	-	Transfers the contents of stack pointer (SP) to register A.
Continuous description	-	Loads the value x in the immediate field to register X, and the value y in the immediate field to register Y. When the LXY instructions are continuously coded and executed, only the first LXY instruction is executed and other LXY instructions coded continuously are skipped.
-	-	Loads the value z in the immediate field to register Z.
(Y) = 0	-	Adds 1 to the contents of register Y. As a result of addition, when the contents of register Y is 0, the next instruction is skipped.
(Y) = 15	-	Subtracts 1 from the contents of register Y. As a result of subtraction, when the contents of register Y is 15, the next instruction is skipped.
-	-	After transferring the contents of M(DP) to register A, an exclusive OR operation is performed between register X and the value j in the immediate field, and stores the result in register X.
-	-	After exchanging the contents of M(DP) with the contents of register A, an exclusive OR operation is performed between register X and the value j in the immediate field, and stores the result in register X.
(Y) = 15	-	After exchanging the contents of M(DP) with the contents of register A, an exclusive OR operation is performed between register X and the value j in the immediate field, and stores the result in register X. Subtracts 1 from the contents of register Y. As a result of subtraction, when the contents of register Y is 15, the next instruction is skipped.
(Y) = 0	-	After exchanging the contents of M(DP) with the contents of register A, an exclusive OR operation is performed between register X and the value j in the immediate field, and stores the result in register X. Adds 1 to the contents of register Y. As a result of addition, when the contents of register Y is 0, the next instruction is skipped.
-	-	After transferring the contents of register A to M(DP), an exclusive OR operation is performed between register X and the value j in the immediate field, and stores the result in register X.

PRELIMINARY
 Notice: This is not a final specification.
 Some parametric limits are subject to change.

MACHINE INSTRUCTIONS (continued)

Parameter Type of instructions	Mnemonic	Instruction code										Hexadecimal notation	Number of words	Number of cycles	Function
		D9	D8	D7	D6	D5	D4	D3	D2	D1	D0				
Arithmetic operation	LA n	0	0	0	1	1	1	n	n	n	n	0 7 n	1	1	(A) ← n n = 0 to 15
	TABP p	0	0	1	0	p5	p4	p3	p2	p1	p0	0 8 p +p	1	3	(SP) ← (SP) + 1 (SK(SP)) ← (PC) (PCH) ← p (PCL) ← (DR2-DR0, A3-A0) (B) ← (ROM(PC)) ₇₋₄ (A) ← (ROM(PC)) ₃₋₀ (PC) ← (SK(SP)) (SP) ← (SP) - 1 (Note)
	AM	0	0	0	0	0	0	1	0	1	0	0 0 A	1	1	(A) ← (A) + (M(DP))
	AMC	0	0	0	0	0	0	1	0	1	1	0 0 B	1	1	(A) ← (A) + (M(DP)) + (CY) (CY) ← Carry
	A n	0	0	0	1	1	0	n	n	n	n	0 6 n	1	1	(A) ← (A) + n n = 0 to 15
	AND	0	0	0	0	0	1	1	0	0	0	0 1 8	1	1	(A) ← (A) AND (M(DP))
	OR	0	0	0	0	0	1	1	0	0	1	0 1 9	1	1	(A) ← (A) OR (M(DP))
	SC	0	0	0	0	0	0	0	1	1	1	0 0 7	1	1	(CY) ← 1
	RC	0	0	0	0	0	0	0	1	1	0	0 0 6	1	1	(CY) ← 0
	SZC	0	0	0	0	1	0	1	1	1	1	0 2 F	1	1	(CY) = 0 ?
	CMA	0	0	0	0	0	1	1	1	0	0	0 1 C	1	1	(A) ← (A̅)
RAR	0	0	0	0	0	1	1	1	0	1	0 1 D	1	1	→ [CY] → [A3A2A1A0] →	
Bit operation	SB j	0	0	0	1	0	1	1	1	j	j	0 5 C +j	1	1	(M _j (DP)) ← 1 j = 0 to 3
	RB j	0	0	0	1	0	0	1	1	j	j	0 4 C +j	1	1	(M _j (DP)) ← 0 j = 0 to 3
	SZB j	0	0	0	0	1	0	0	0	j	j	0 2 j	1	1	(M _j (DP)) = 0 ? j = 0 to 3
Comparison operation	SEAM	0	0	0	0	1	0	0	1	1	0	0 2 6	1	1	(A) = (M(DP)) ?
	SEA n	0	0	0	0	1	0	0	1	0	1	0 2 5	2	2	(A) = n ? n = 0 to 15
		0	0	0	1	1	1	n	n	n	n	0 7 n			

Note : p is 0 to 15 for M34512M2, p is 0 to 31 for M34512M4.

PRELIMINARY
 Notice: This is not a final specification.
 Some parametric limits are subject to
 change.

Skip condition	Carry flag CY	Detailed description
Continuous description - - - Overflow = 0 - - - - (CY) = 0 - -	- - 0/1 - - 1 0 - - 0/1	Loads the value n in the immediate field to register A. When the LA instructions are continuously coded and executed, only the first LA instruction is executed and other LA instructions coded continuously are skipped. Transfers bits 7 to 4 to register B and bits 3 to 0 to register A. These bits 7 to 0 are the ROM pattern in address (DR2 DR1 DR0 A3 A2 A1 A0) ₂ specified by registers A and D in page p. When this instruction is executed, 1 stage of stack register is used. Adds the contents of M(DP) to register A. Stores the result in register A. The contents of carry flag CY remains unchanged. Adds the contents of M(DP) and carry flag CY to register A. Stores the result in register A and carry flag CY. Adds the value n in the immediate field to register A. The contents of carry flag CY remains unchanged. Skips the next instruction when there is no overflow as the result of operation. Takes the AND operation between the contents of register A and the contents of M(DP), and stores the result in register A. Takes the OR operation between the contents of register A and the contents of M(DP), and stores the result in register A. Sets (1) to carry flag CY. Clears (0) to carry flag CY. Skips the next instruction when the contents of carry flag CY is "0." Stores the one's complement for register A's contents in register A. Rotates 1 bit of the contents of register A including the contents of carry flag CY to the right.
- - (Mj(DP)) = 0 j = 0 to 3	- - -	Sets (1) the contents of bit j (bit specified by the value j in the immediate field) of M(DP). Clears (0) the contents of bit j (bit specified by the value j in the immediate field) of M(DP). Skips the next instruction when the contents of bit j (bit specified by the value j in the immediate field) of M(DP) is "0."
(A) = (M(DP)) (A) = n	- -	Skips the next instruction when the contents of register A is equal to the contents of M(DP). Skips the next instruction when the contents of register A is equal to the value n in the immediate field.

PRELIMINARY
 Notice: This is not a final specification.
 Some parametric limits are subject to change.

MACHINE INSTRUCTIONS (continued)

Parameter Type of instructions	Mnemonic	Instruction code										Hexadecimal notation	Number of words	Number of cycles	Function
		D9	D8	D7	D6	D5	D4	D3	D2	D1	D0				
Branch operation	B a	0	1	1	a6	a5	a4	a3	a2	a1	a0	1 8 a +a	1	1	(PCL) ← a6-a0
	BL p, a	0	0	1	1	1	p4	p3	p2	p1	p0	0 E p +p	2	2	(PCH) ← p (PCL) ← a6-a0 (Note)
		1	0	p5	a6	a5	a4	a3	a2	a1	a0	2 p a +a			
	BLA p	0	0	0	0	0	1	0	0	0	0	0 1 0	2	2	(PCH) ← p (PCL) ← (DR2-DR0, A3-A0) (Note)
1		0	p5	p4	0	0	p3	p2	p1	p0	2 p p				
Subroutine operation	BM a	0	1	0	a6	a5	a4	a3	a2	a1	a0	1 a a	1	1	(SP) ← (SP) + 1 (SK(SP)) ← (PC) (PCH) ← 2 (PCL) ← a6-a0
	BML p, a	0	0	1	1	0	p4	p3	p2	p1	p0	0 C p +p	2	2	(SP) ← (SP) + 1 (SK(SP)) ← (PC) (PCH) ← p (PCL) ← a6-a0 (Note)
		1	0	p5	a6	a5	a4	a3	a2	a1	a0	2 p a +a			
	BMLA p	0	0	0	0	1	1	0	0	0	0	0 3 0	2	2	(SP) ← (SP) + 1 (SK(SP)) ← (PC) (PCH) ← p (PCL) ← (DR2-DR0, A3-A0) (Note)
1		0	p5	p4	0	0	p3	p2	p1	p0	2 p p				
Return operation	RTI	0	0	0	1	0	0	0	1	1	0	0 4 6	1	1	(PC) ← (SK(SP)) (SP) ← (SP) - 1
	RT	0	0	0	1	0	0	0	1	0	0	0 4 4	1	2	(PC) ← (SK(SP)) (SP) ← (SP) - 1
	RTS	0	0	0	1	0	0	0	1	0	1	0 4 5	1	2	(PC) ← (SK(SP)) (SP) ← (SP) - 1
Interrupt operation	DI	0	0	0	0	0	0	0	1	0	0	0 0 4	1	1	(INTE) ← 0
	EI	0	0	0	0	0	0	0	1	0	1	0 0 5	1	1	(INTE) ← 1
	SNZ0	0	0	0	0	1	1	1	0	0	0	0 3 8	1	1	(EXF0) = 1 ? After skipping (EXF0) ← 0
	SNZ1	0	0	0	0	1	1	1	0	0	1	0 3 9	1	1	(EXF1) = 1 ? After skipping (EXF1) ← 0

Note : p is 0 to 15 for M34512M2, p is 0 to 31 for M34512M4.

PRELIMINARY
 Notice: This is not a final specification.
 Some parametric limits are subject to
 change.

Skip condition	Carry flag CY	Detailed description
-	-	Branch within a page : Branches to address a in the identical page.
-	-	Branch out of a page : Branches to address a in page p.
-	-	Branch out of a page : Branches to address (DR2 DR1 DR0 A3 A2 A1 A0) ₂ specified by registers D and A in page p.
-	-	Call the subroutine in page 2 : Calls the subroutine at address a in page 2.
-	-	Call the subroutine : Calls the subroutine at address a in page p.
-	-	Call the subroutine : Calls the subroutine at address (DR2 DR1 DR0 A3 A2 A1 A0) ₂ specified by registers D and A in page p.
-	-	Returns from interrupt service routine to main routine. Returns each value of data pointer (X, Y, Z), carry flag, skip status, NOP mode status by the continuous description of the LA/LXY instruction, register A and register B to the states just before interrupt.
-	-	Returns from subroutine to the routine called the subroutine.
Skip at uncondition	-	Returns from subroutine to the routine called the subroutine, and skips the next instruction at uncondition.
-	-	Clears (0) to the interrupt enable flag INTE, and disables the interrupt.
-	-	Sets (1) to the interrupt enable flag INTE, and enables the interrupt.
(EXF0) = 1	-	Skips the next instruction when the contents of EXF0 flag is "1." After skipping, clears (0) to the EXF0 flag.
(EXF1) = 1	-	Skips the next instruction when the contents of EXF1 flag is "1." After skipping, clears (0) to the EXF1 flag.

PRELIMINARY
 Notice: This is not a final specification.
 Some parametric limits are subject to change.

MACHINE INSTRUCTIONS (continued)

Parameter Type of instructions	Mnemonic	Instruction code										Hexadecimal notation	Number of words	Number of cycles	Function
		D9	D8	D7	D6	D5	D4	D3	D2	D1	D0				
Interrupt operation	SNZI0	0	0	0	0	1	1	1	0	1	0	0 3 A	1	1	I12 = 1 : (INT0) = "H" ? I12 = 0 : (INT0) = "L" ?
	SNZI1	0	0	0	0	1	1	1	0	1	1	0 3 B	1	1	I22 = 1 : (INT1) = "H" ? I22 = 0 : (INT1) = "L" ?
	TAV1	0	0	0	1	0	1	0	1	0	0	0 5 4	1	1	(A) ← (V1)
	TV1A	0	0	0	0	1	1	1	1	1	1	0 3 F	1	1	(V1) ← (A)
	TAV2	0	0	0	1	0	1	0	1	0	1	0 5 5	1	1	(A) ← (V2)
	TV2A	0	0	0	0	1	1	1	1	1	0	0 3 E	1	1	(V2) ← (A)
	TAI1	1	0	0	1	0	1	0	0	1	1	2 5 3	1	1	(A) ← (I1)
	TI1A	1	0	0	0	0	1	0	1	1	1	2 1 7	1	1	(I1) ← (A)
	TAI2	1	0	0	1	0	1	0	1	0	0	2 5 4	1	1	(A) ← (I2)
TI2A	1	0	0	0	0	1	1	0	0	0	2 1 8	1	1	(I2) ← (A)	
Timer operation	TAW1	1	0	0	1	0	0	1	0	1	1	2 4 B	1	1	(A) ← (W1)
	TW1A	1	0	0	0	0	0	1	1	1	0	2 0 E	1	1	(W1) ← (A)
	TAW2	1	0	0	1	0	0	1	1	0	0	2 4 C	1	1	(A) ← (W2)
	TW2A	1	0	0	0	0	0	1	1	1	1	2 0 F	1	1	(W2) ← (A)
	TAW3	1	0	0	1	0	0	1	1	0	1	2 4 D	1	1	(A) ← (W3)
	TW3A	1	0	0	0	0	1	0	0	0	0	2 1 0	1	1	(W3) ← (A)
	TAW4	1	0	0	1	0	0	1	1	1	0	2 4 E	1	1	(A) ← (W4)
	TW4A	1	0	0	0	0	1	0	0	0	1	2 1 1	1	1	(W4) ← (A)
	TAB1	1	0	0	1	1	1	0	0	0	0	2 7 0	1	1	(B) ← (T17-T14) (A) ← (T13-T10)
	T1AB	1	0	0	0	1	1	0	0	0	0	2 3 0	1	1	(R17-R14) ← (B) (T17-T14) ← (B) (R13-R10) ← (A) (T13-T10) ← (A)
	TAB2	1	0	0	1	1	1	0	0	0	1	2 7 1	1	1	(B) ← (T27-T24) (A) ← (T23-T20)
T2AB	1	0	0	0	1	1	0	0	0	1	2 3 1	1	1	(R27-R24) ← (B) (T27-T24) ← (B) (R23-R20) ← (A) (T23-T20) ← (A)	

PRELIMINARY
 Notice: This is not a final specification.
 Some parametric limits are subject to
 change.

MACHINE INSTRUCTIONS (continued)

Parameter Type of instructions	Mnemonic	Instruction code											Number of words	Number of cycles	Function
		D9	D8	D7	D6	D5	D4	D3	D2	D1	D0	Hexadecimal notation			
Timer operation	TAB3	1	0	0	1	1	1	0	0	1	0	2 7 2	1	1	(B) ← (T37-T34) (A) ← (T33-T30)
	T3AB	1	0	0	0	1	1	0	0	1	0	2 3 2	1	1	(R37-R34) ← (B) (T37-T34) ← (B) (R33-R30) ← (A) (T33-T30) ← (A)
	TAB4	1	0	0	1	1	1	0	0	1	1	2 7 3	1	1	(B) ← (T47-T44) (A) ← (T43-T40)
	T4AB	1	0	0	0	1	1	0	0	1	1	2 3 3	1	1	(R47-R44) ← (B) (T47-T44) ← (B) (R43-R40) ← (A) (T43-T40) ← (A)
	TR1AB	1	0	0	0	1	1	1	1	1	1	2 3 F	1	1	(R17-R14) ← (B) (R13-R10) ← (A)
	TR3AB	1	0	0	0	1	1	1	0	1	1	2 3 B	1	1	(R37-R34) ← (B) (R33-R30) ← (A)
	SNZT1	1	0	1	0	0	0	0	0	0	0	2 8 0	1	1	(T1F) = 1 ? After skipping (T1F) ← 0
	SNZT2	1	0	1	0	0	0	0	0	0	1	2 8 1	1	1	(T2F) = 1 ? After skipping (T2F) ← 0
	SNZT3	1	0	1	0	0	0	0	0	1	0	2 8 2	1	1	(T3F) = 1 ? After skipping (T3F) ← 0
	SNZT4	1	0	1	0	0	0	0	0	1	1	2 8 3	1	1	(T4F) = 1 ? After skipping (T4F) ← 0

PRELIMINARY
 Notice: This is not a final specification.
 Some parametric limits are subject to change.

Skip condition	Carry flag CY	Detailed description
-	-	Transfers the contents of timer 3 to registers A and B.
-	-	Transfers the contents of registers A and B to timer 3 and timer 3 reload register.
-	-	Transfers the contents of timer 4 to registers A and B.
-	-	Transfers the contents of registers A and B to timer 4 and timer 4 reload register.
-	-	Transfers the contents of registers A and B to timer 1 reload register.
-	-	Transfers the contents of registers A and B to timer 3 reload register.
(T1F) = 1	-	Skips the next instruction when the contents of T1F flag is "1." After skipping, clears (0) to T1F flag.
(T2F) = 1	-	Skips the next instruction when the contents of T2F flag is "1." After skipping, clears (0) to T2F flag.
(T3F) = 1	-	Skips the next instruction when the contents of T3F flag is "1." After skipping, clears (0) to T3F flag.
(T4F) = 1	-	Skips the next instruction when the contents of T4F flag is "1." After skipping, clears (0) to T4F flag.

PRELIMINARY
 Notice: This is not a final specification.
 Some parametric limits are subject to change.

MACHINE INSTRUCTIONS (continued)

Parameter Type of instructions	Mnemonic	Instruction code											Number of words	Number of cycles	Function
		D9	D8	D7	D6	D5	D4	D3	D2	D1	D0	Hexadecimal notation			
Input/Output operation	IAP0	1	0	0	1	1	0	0	0	0	0	2 6 0	1	1	(A) ← (P0)
	OP0A	1	0	0	0	1	0	0	0	0	0	2 2 0	1	1	(P0) ← (A)
	IAP1	1	0	0	1	1	0	0	0	0	1	2 6 1	1	1	(A) ← (P1)
	OP1A	1	0	0	0	1	0	0	0	0	1	2 2 1	1	1	(P1) ← (A)
	IAP2	1	0	0	1	1	0	0	0	1	0	2 6 2	1	1	(A ₂ -A ₀) ← (P ₂₂ -P ₂₀) (A ₃) ← 0
	CLD	0	0	0	0	0	1	0	0	0	1	0 1 1	1	1	(D) ← 1
	RD	0	0	0	0	0	1	0	1	0	0	0 1 4	1	1	(D(Y)) ← 0 (Y) = 0 to 7
	SD	0	0	0	0	0	1	0	1	0	1	0 1 5	1	1	(D(Y)) ← 1 (Y) = 0 to 7
	SZD	0	0	0	0	1	0	0	1	0	0	0 2 4	2	2	(D(Y)) = 0 ? (Y) = 0 to 7
		0	0	0	0	1	0	1	0	1	1	0 2 B			
	TK0A	1	0	0	0	0	1	1	0	1	1	2 1 B	1	1	(K0) ← (A)
	TAK0	1	0	0	1	0	1	0	1	1	0	2 5 6	1	1	(A) ← (K0)
	TPU0A	1	0	0	0	1	0	1	1	0	1	2 2 D	1	1	(PU0) ← (A)
	TAPU0	1	0	0	1	0	1	0	1	1	1	2 5 7	1	1	(A) ← (PU0)
Serial I/O control operation	TABSI	1	0	0	1	1	1	1	0	0	0	2 7 8	1	1	(A) ← (SI ₃ -SI ₀) (B) ← (SI ₇ -SI ₄)
	TSIAB	1	0	0	0	1	1	1	0	0	0	2 3 8	1	1	(SI ₃ -SI ₀) ← (A) (SI ₇ -SI ₄) ← (B)
	TAJ1	1	0	0	1	0	0	0	0	1	0	2 4 2	1	1	(A) ← (J1)
	TJ1A	1	0	0	0	0	0	0	0	1	0	2 0 2	1	1	(J1) ← (A)
	SST	1	0	1	0	0	1	1	1	1	0	2 9 E	1	1	(SIOF) ← 0 Serial I/O starting
	SNZSI	1	0	1	0	0	0	1	0	0	0	2 8 8	1	1	(SIOF) = 1 ? After skipping (SIOF) ← 0

PRELIMINARY
 Notice: This is not a final specification.
 Some parametric limits are subject to
 change.

Skip condition	Carry flag CY	Detailed description
<ul style="list-style-type: none"> - - - - - - - - - (D(Y)) = 0 (Y) = 0 to 7 - - - - 	<ul style="list-style-type: none"> - - - - - - - - - - - - - - 	<ul style="list-style-type: none"> - Transfers the input of port P0 to register A. - Outputs the contents of register A to port P0. - Transfers the input of port P1 to register A. - Outputs the contents of register A to port P1. - Transfers the input of port P2 to register A. - Sets (1) to port D. - Clears (0) to a bit of port D specified by register Y. - Sets (1) to a bit of port D specified by register Y. - Skips the next instruction when a bit of port D specified by register Y is "0." - Transfers the contents of register A to key-on wakeup control register K0. - Transfers the contents of key-on wakeup control register K0 to register A. - Transfers the contents of register A to pull-up control register PU0. - Transfers the contents of pull-up control register PU0 to register A.
<ul style="list-style-type: none"> - - - - - (SIOF) = 1 	<ul style="list-style-type: none"> - - - - - - 	<ul style="list-style-type: none"> - Transfers the contents of serial I/O register SI to registers A and B. - Transfers the contents of registers A and B to serial I/O register SI. - Transfers the contents of serial I/O mode register J1 to register A. - Transfers the contents of register A to serial I/O mode register J1. - Clears (0) to SIOF flag and starts serial I/O. - Skips the next instruction when the contents of SIOF flag is "1." After skipping, clears (0) to SIOF flag.

PRELIMINARY
 Notice: This is not a final specification.
 Some parametric limits are subject to change.

MACHINE INSTRUCTIONS (continued)

Parameter Type of instructions	Mnemonic	Instruction code											Number of words	Number of cycles	Function
		D9	D8	D7	D6	D5	D4	D3	D2	D1	D0	Hexadecimal notation			
A-D conversion operation	TABAD	1	0	0	1	1	1	1	0	0	1	2 7 9	1	1	(A) ← (AD5-AD2) (B) ← (AD9-AD6) However, in the comparator mode, (A) ← (AD3-AD0) (B) ← (AD7-AD4)
	TALA	1	0	0	1	0	0	1	0	0	1	2 4 9	1	1	(A) ← (AD1, AD0, 0, 0)
	TADAB	1	0	0	0	1	1	1	0	0	1	2 3 9	1	1	(AD3-AD0) ← (A) (AD7-AD4) ← (B)
	TAQ1	1	0	0	1	0	0	0	1	0	0	2 4 4	1	1	(A) ← (Q1)
	TQ1A	1	0	0	0	0	0	0	1	0	0	2 0 4	1	1	(Q1) ← (A)
	ADST	1	0	1	0	0	1	1	1	1	1	2 9 F	1	1	(ADF) ← 0 A-D conversion starting
	SNZAD	1	0	1	0	0	0	0	1	1	1	2 8 7	1	1	(ADF) = 1 ? After skipping (ADF) ← 0
	TAQ2	1	0	0	1	0	0	0	1	0	1	2 4 5	1	1	(A) ← (Q2)
	TQ2A	1	0	0	0	0	0	0	1	0	1	2 0 5	1	1	(Q2) ← (A)
Other operation	NOP	0	0	0	0	0	0	0	0	0	0	0 0 0	1	1	(PC) ← (PC) + 1
	POF	0	0	0	0	0	0	0	0	1	0	0 0 2	1	1	RAM back-up
	EPOF	0	0	0	1	0	1	1	0	1	1	0 5 B	1	1	POF instruction valid
	SNZP	0	0	0	0	0	0	0	0	1	1	0 0 3	1	1	(P) = 1 ?
	WRST	1	0	1	0	1	0	0	0	0	0	2 A 0	1	1	(WDF1) ← 0 (WEF) ← 1
	TAMR	1	0	0	1	0	1	0	0	1	0	2 5 2	1	1	(A) ← (MR)
	TMRA	1	0	0	0	0	1	0	1	1	0	2 1 6	1	1	(MR) ← (A)

PRELIMINARY
 Notice: This is not a final specification.
 Some parametric limits are subject to
 change.

Skip condition	Carry flag CY	Detailed description
-	-	Transfers the high-order 8 bits of the contents of register AD to registers A and B.
-	-	Transfers the low-order 2 bits of the contents of register AD to the high-order 2 bits of the contents of register A. Simultaneously, the low-order 2 bits of the contents of the register A is "0."
-	-	Transfers the contents of registers A and B to the comparator register at the comparator mode.
-	-	Transfers the contents of the A-D control register Q1 to register A.
-	-	Transfers the contents of register A to the A-D control register Q1.
-	-	Clears the ADF flag, and the A-D conversion at the A-D conversion mode or the comparator operation at the comparator mode is started.
(ADF) = 1	-	Skips the next instruction when the contents of ADF flag is "1". After skipping, clears (0) the contents of ADF flag.
-	-	Transfers the contents of the A-D control register Q2 to register A.
-	-	Transfers the contents of register A to the A-D control register Q2.
-	-	No operation
-	-	Puts the system in RAM back-up state by executing the POF instruction after executing the EPOF instruction.
-	-	Makes the immediate POF instruction valid by executing the EPOF instruction.
(P) = 1	-	Skips the next instruction when P flag is "1". After skipping, P flag remains unchanged.
-	-	Operates the watchdog timer and initializes the watchdog timer flag WDF1.
-	-	Transfers the contents of the clock control register MR to register A.
-	-	Transfers the contents of register A to the clock control register MR.

PRELIMINARY
 Notice: This is not a final specification.
 Some parametric limits are subject to
 change.

ABSOLUTE MAXIMUM RAIINGS

Symbol	Parameter	Conditions	Ratings	Unit
V _{DD}	Supply voltage		-0.3 to 7.0	V
V _I	Input voltage P0, P1, P2, INT0, INT1, RESET, X _{IN}		-0.3 to V _{DD} +0.3	V
V _I	Input voltage D ₀ -D ₇		-0.3 to 13	V
V _I	Input voltage A _{IN0} -A _{IN3}		-0.3 to V _{DD} +0.3	V
V _O	Output voltage P0, P1, RESET	Output transistors in cut-off state	-0.3 to V _{DD} +0.3	V
V _O	Output voltage D ₀ -D ₇		-0.3 to 13	V
V _O	Output voltage X _{OUT}		-0.3 to V _{DD} +0.3	V
P _d	Power dissipation	T _a = 25 °C	300	mW
Topr	Operating temperature range		-20 to 85	°C
Tstg	Storage temperature range		-40 to 125	°C

RECOMMENDED OPERATING CONDITIONS (T_a = -20 °C to 85 °C, V_{DD} = 4.0 V to 5.5 V, unless otherwise noted)

Symbol	Parameter	Conditions	Limits			Unit
			Min.	Typ.	Max.	
V _{DD}	Supply voltage	f(X _{IN}) ≤ 4.2 MHz	4.0		5.5	V
V _{RAM}	RAM back-up voltage (at RAM back-up mode)		1.8			
V _{SS}	Supply voltage			0		
V _{IH}	"H" level input voltage P0, P1, P2, X _{IN}		0.8V _{DD}		V _{DD}	
V _{IH}	"H" level input voltage D ₀ -D ₇		0.8V _{DD}		12	
V _{IH}	"H" level input voltage RESET		0.85V _{DD}		V _{DD}	
V _{IH}	"H" level input voltage S _{IN} , S _{CK} , INT0, INT1		0.85V _{DD}		V _{DD}	
V _{IL}	"L" level input voltage P0, P1, P2, D ₀ -D ₇ , X _{IN}		0		0.2V _{DD}	
V _{IL}	"L" level input voltage RESET		0		0.3V _{DD}	
V _{IL}	"L" level input voltage S _{IN} , S _{CK} , INT0, INT1		0		0.15V _{DD}	
I _{OL} (peak)	"L" level peak output current RESET	V _{DD} = 5.0 V			10	mA
I _{OL} (peak)	"L" level peak output current D ₆ , D ₇	V _{DD} = 5.0 V			40	
I _{OL} (peak)	"L" level peak output current D ₀ -D ₅	V _{DD} = 5.0 V			24	
I _{OL} (peak)	"L" level peak output current P0, P1, S _{CK} , S _{OUT}	V _{DD} = 5.0 V			24	
I _{OL} (avg)	"L" level average output current RESET (Note)	V _{DD} = 5.0 V			5	
I _{OL} (avg)	"L" level average output current D ₆ , D ₇ (Note)	V _{DD} = 5.0 V			30	
I _{OL} (avg)	"L" level average output current D ₀ -D ₅ (Note)	V _{DD} = 5.0 V			15	
I _{OL} (avg)	"L" level average output current P0, P1, S _{CK} , S _{OUT} (Note)	V _{DD} = 5.0 V			12	
ΣI _{OL} (avg)	"L" level total average current D, RESET, S _{CK} , S _{OUT}				80	
	"L" level total average current P0, P1				80	
f(X _{IN})	Oscillation frequency (at ceramic resonance)	V _{DD} = 4.0 V to 5.5 V			4.2	MHz
	Oscillation frequency (at external clock input)	V _{DD} = 4.0 V to 5.5 V			3.0	
tw(S _{CK})	Serial I/O external clock cycle (pulse width of "H" and "L")	V _{DD} = 4.0 V to 5.5 V	750			ns

Note: The average output current (I_{OL}) is the average value during 100 ms.

PRELIMINARY
 Notice: This is not a final specification.
 Some parametric limits are subject to
 change.

ELECTRICAL CHARACTERISTICS (Ta = -20 °C to 85 °C, VDD = 4.0 V to 5.5 V, unless otherwise noted)

Symbol	Parameter	Test conditions		Limits			Unit	
				Min.	Typ.	Max.		
VOL	"L" level output voltage P0, P1	VDD = 5 V	IOL = 12 mA			2	V	
VOL	"L" level output voltage RESET	VDD = 5 V	IOL = 5 mA			2	V	
VOL	"L" level output voltage D6, D7	VDD = 5 V	IOL = 30 mA			2	V	
			IOL = 10 mA			0.9		
VOL	"L" level output voltage D0-D5	VDD = 5 V	IOL = 15 mA			2	V	
IiH	"H" level input current P0, P1, P2, RESET	Vi = VDD				1	μA	
IiH	"H" level input current D0-D7	Vi = 12 V				1	μA	
IiL	"L" level input current P0, P1, P2, RESET	Vi = 0 V No pull-up of ports P0 and P1		-1			μA	
IiL	"L" level input current D0-D7	Vi = 0 V		-1			μA	
IDD	Supply current	at active mode	VDD = 5 V	f(XIN) = 4.0 MHz	1.8	5.5	mA	
			Middle-speed mode		f(XIN) = 400 kHz	0.5		1.5
			VDD = 5 V	f(XIN) = 4.0 MHz	3.0	9.0		
			High-speed mode		f(XIN) = 400 kHz	0.6		1.8
		at RAM back-up mode	Ta = 25 °C			0.1	1	μA
			VDD = 5 V				10	
RPU	Pull-up resistor value	VDD = 5 V	Vi = 0 V	20	50	125	kΩ	
VT+ - VT-	Hysteresis INT0, INT1, SIN, SCK	VDD = 5 V			0.3		V	
VT+ - VT-	Hysteresis RESET	VDD = 5 V			1.5		V	

BASIC TIMING DIAGRAM

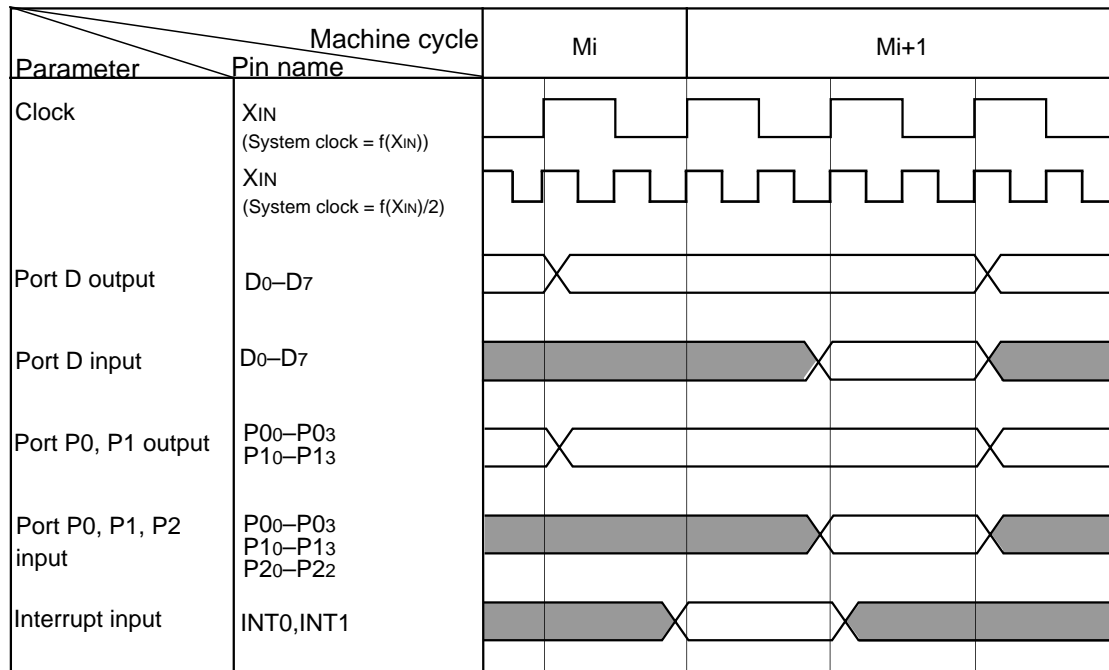

PRELIMINARY
 Notice: This is not a final specification.
 Some parametric limits are subject to
 change.

A-D CONVERTER RECOMMENDED OPERATING CONDITIONS

(Comparator mode included, Ta = -20 °C to 85 °C, unless otherwise noted)

Symbol	Parameter	Conditions	Limits			Unit
			Min.	Typ.	Max.	
VDD	Supply voltage		4.0		5.5	V
VIA	Analog input voltage		0		VDD	V
f(XIN)	Oscillation frequency	Middle-speed mode	0.8			MHz
		High-speed mode	0.4			MHz

A-D CONVERTER CHARACTERISTICS (Ta = -20 °C to 85 °C, unless otherwise noted)

Symbol	Parameter	Test conditions	Limits			Unit
			Min.	Typ.	Max.	
-	Resolution				10	bits
-	Linearity error	Ta = -25 °C to 85 °C, VDD = 4.0 V to 5.5 V			±2	LSB
-	Differential non-linearity error	Ta = -25 °C to 85 °C, VDD = 4.0 V to 5.5 V			±0.9	LSB
V0T	Zero transition voltage	VDD = 5.12 V	0	5	20	mV
VFST	Full-scale transition voltage	VDD = 5.12 V	5105	5115	5125	mV
IADD	A-D operating current	VDD = 5.0 V f(XIN) = 0.4 MHz to 4.0 MHz		0.7	2.0	mA
TCONV	A-D conversion time	f(XIN) = 4.0 MHz, Middle-speed mode			93.0	μs
		f(XIN) = 4.0 MHz, High-speed mode			46.5	
-	Comparator resolution	Comparator mode			8	bits
-	Comparator error (Note)	VDD = 5.12 V			±20	mV
-	Comparator comparison time	f(XIN) = 4.0 MHz, Middle-speed mode			12	μs
		f(XIN) = 4.0 MHz, High-speed mode			6	

Note: As for the error from the logic value in the comparator mode, when the contents of the comparator register is n, the logic value of the comparison voltage Vref which is generated by the built-in DA converter can be obtained by the following formula.

Logic value of comparison voltage Vref

$$V_{ref} = \frac{V_{DD}}{256} \times n$$

n = Value of register AD (n = 0 to 255)

PRELIMINARY
 Notice: This is not a final specification.
 Some parametric limits are subject to
 change.

GZZ-SH52-46B <81A0>

**4500 SERIES MASK ROM ORDER CONFIRMATION FORM
 SINGLE-CHIP MICROCOMPUTER M34512M4-XXXXP
 MITSUBISHI ELECTRIC**

Please fill in all items marked *.

Mask ROM number	
-----------------	--

Receipt	Date:	
	Section head signature	Supervisor signature

* Customer	Company name		TEL ()
	Date issued	Date:	

Issuance signature	Responsible officer	Supervisor

* 1. Confirmation

Specify the type of EPROMs submitted.

Three sets of EPROMs are required for each pattern (check in the approximate box).

If at least two of the three sets of EPROMs submitted contain the identical data, we will produce masks based on this data. We shall assume the responsibility for errors only if the mask ROM data on the products we produce differ from this data. Thus, the customer must be especially careful in verifying the data contained in the EPROMs submitted.

Checksum code for entire EPROM area

--	--	--	--

 (hexadecimal notation)

EPROM Type:

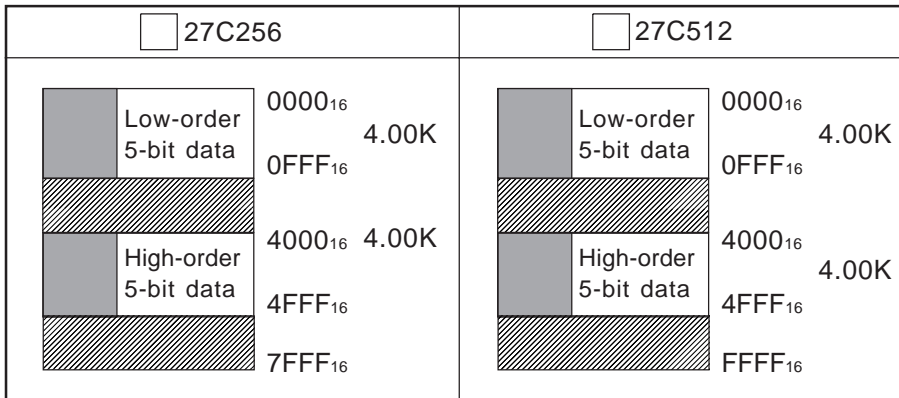

Set "FF₁₆" in the shaded area.

Set "1112" in the area

--

 of low-order and high-order 5-bit data.

* 2. Mark Specification

Mark specification must be submitted using the correct form for the type of package being ordered.

Fill out the approximate Mark Specification Form (32P6B-A for M34512M4-XXXXP) and attach to the Mask ROM Order Confirmation Form.

* 3. Comments

PRELIMINARY
 Notice: This is not a final specification.
 Some parametric limits are subject to change.

32P6B (32-PIN LQFP) MARK SPECIFICATION FORM

Mitsubishi IC catalog name

Please choose one of the marking types below (A, B), and enter the Mitsubishi catalog name and the special mark (if needed).

A. Standard Mitsubishi Mark

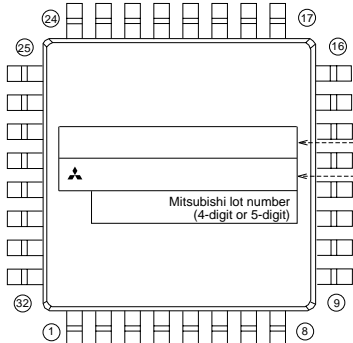

Mitsubishi IC catalog name
 Mitsubishi IC catalog name

Note: If the Mitsubishi logo is not required, check the box on the right.

Mitsubishi logo is not required

B. Customer's Parts Number + Mitsubishi catalog name

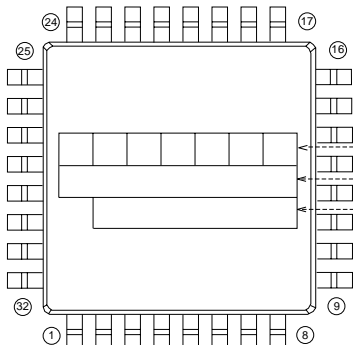

Customer's Parts Number

Note : The fonts and size of characters are standard Mitsubishi type.

Mitsubishi IC catalog name

Note1 : The mark field should be written right aligned.

2 : The fonts and size of characters are standard Mitsubishi type.

(The Mitsubishi logo is not marked.)

3 : Customer's Parts Number can be up to 7 characters : Only 0 ~ 9, A ~ Z, —(hyphen), . (periods), , (commas) are usable.

C. Customer's Parts Number

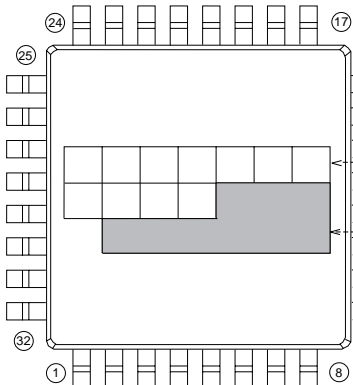

Customer's Parts Number

Note : The fonts and size of characters are standard Mitsubishi type.

Shaded area: Mitsubishi lot number (4-digit or 5-digit) and Mask ROM number (3-digit) are always marked, for products classification.

Note1 : The mark field should be written right aligned.

2 : The fonts and size of characters are standard Mitsubishi type.

3 : Customer's Parts Number can be up to 11 characters : Only 0 ~ 9, A ~ Z, —(hyphen), . (periods), , (commas) are usable.

PRELIMINARY
 Notice: This is not a final specification.
 Some parametric limits are subject to
 change.

PACKAGE OUTLINE

32P6B-A

Plastic 32pin 7X7mm body LQFP

EIAJ Package Code	JEDEC Code	Weight(g)	Lead Material
LQFP32-P-77-0.80	-		Alloy 42

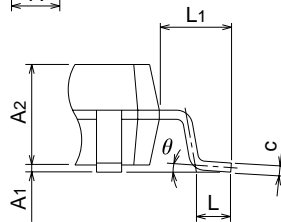
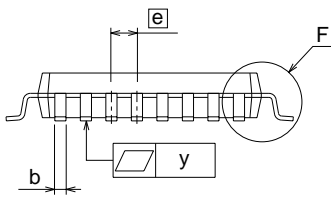
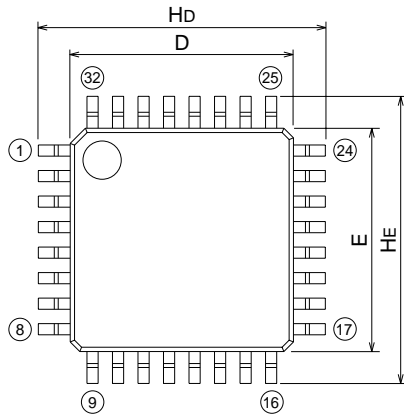

Detail F

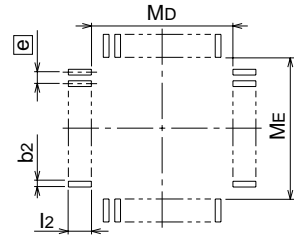

Recommended Mount Pad

Symbol	Dimension in Millimeters		
	Min	Nom	Max
A	-	-	1.7
A1	0	0.1	0.2
A2	-	1.4	-
b	0.3	0.35	0.45
c	0.105	0.125	0.175
D	6.9	7.0	7.1
E	6.9	7.0	7.1
e	-	0.8	-
HD	8.8	9.0	9.2
HE	8.8	9.0	9.2
L	0.3	0.5	0.7
L1	-	1.0	-
y	-	-	0.1
θ	0°	-	10°
b2	-	0.5	-
l2	1.0	-	-
MD	-	7.4	-
ME	-	7.4	-

Keep safety first in your circuit designs!

- Mitsubishi Electric Corporation puts the maximum effort into making semiconductor products better and more reliable, but there is always the possibility that trouble may occur with them. Trouble with semiconductors may lead to personal injury, fire or property damage. Remember to give due consideration to safety when making your circuit designs, with appropriate measures such as (i) placement of substitutive, auxiliary circuits, (ii) use of non-flammable material or (iii) prevention against any malfunction or mishap.

Notes regarding these materials

- These materials are intended as a reference to assist our customers in the selection of the Mitsubishi semiconductor product best suited to the customer's application; they do not convey any license under any intellectual property rights, or any other rights, belonging to Mitsubishi Electric Corporation or a third party.
- Mitsubishi Electric Corporation assumes no responsibility for any damage, or infringement of any third-party's rights, originating in the use of any product data, diagrams, charts or circuit application examples contained in these materials.
- All information contained in these materials, including product data, diagrams and charts, represent information on products at the time of publication of these materials, and are subject to change by Mitsubishi Electric Corporation without notice due to product improvements or other reasons. It is therefore recommended that customers contact Mitsubishi Electric Corporation or an authorized Mitsubishi Semiconductor product distributor for the latest product information before purchasing a product listed herein.
- Mitsubishi Electric Corporation semiconductors are not designed or manufactured for use in a device or system that is used under circumstances in which human life is potentially at stake. Please contact Mitsubishi Electric Corporation or an authorized Mitsubishi Semiconductor product distributor when considering the use of a product contained herein for any specific purposes, such as apparatus or systems for transportation, vehicular, medical, aerospace, nuclear, or undersea repeater use.
- The prior written approval of Mitsubishi Electric Corporation is necessary to reprint or reproduce in whole or in part these materials.
- If these products or technologies are subject to the Japanese export control restrictions, they must be exported under a license from the Japanese government and cannot be imported into a country other than the approved destination.
Any diversion or reexport contrary to the export control laws and regulations of Japan and/or the country of destination is prohibited.
- Please contact Mitsubishi Electric Corporation or an authorized Mitsubishi Semiconductor product distributor for further details on these materials or the products contained therein.