

Sound processor for CD radio cassette player BD3871FS

● Description

BD3871FS is a sound processor for CD/MD radio cassette player. This IC provides all functions, such as input selector (3 input sources), an input gain amplifier (25dB, 27dB, 29dB), and a surround, tone (bass, treble). This IC can be controlled by a 2-wire serial data interface.

● Dimension (Units : mm)

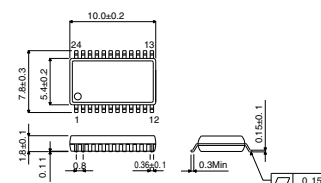

SSOP-A24

● Features

- 1) Can select center frequency and Q value of Bass characteristics by external components.
- 2) Mute switch at the input terminal can reduce cross talk.
- 3) Surround function is composed without external components.
- 4) Ideal for energy-saving designs with low current consumption due to the adoption of the BiCMOS process, allowing easy-design of the regulator blocks in the set.

● Applications

CD radio cassette player, MD radio cassette player, Micro component stereo

● Absolute Maximum Ratings (Ta=25°C)

Parameter	Symbol	Limits	Unit
Power supply voltage	Vcc	10	V
Power dissipation	Pd	800	mW
Operating temperature range	Topr	-25 ~ +75	°C
Storage temperature range	Tstg	-55 ~ +125	°C

Derating : 8.0mW/°C for operation above Ta=25°C

● Recommended Operating Conditions (Ta=25°C)

Parameter	Symbol	Min.	Typ.	Max.	Unit
Operating voltage	V _{DD}	4.5	8	9.5	V

● Electrical characteristics

(Unless otherwise noted ; $T_a=25^{\circ}\text{C}$, $V_{cc}=8\text{V}$, $f=1\text{kHz}$, $V_i=50\text{mVrms}$, $R_L=10\text{k}$, $R_g=600$,
 INPUT GAIN=24dB, $V_{ol}=0\text{dB}$, bass,treble=0dB, surround=OFF)

Parameter	Symbol	Min.	Typ.	Max.	Unit	Conditions
Circuit current	I_Q	—	8	21	mA	No signal
Output voltage gain	G_v	22	24	26	dB	
Total harmonic distortion	THD	—	0.01	0.1	%	$V_{OUT}=1\text{Vrms}$, $B_w=400\sim 30\text{kHz}$
Maximum output voltage	V_{omax}	1.6	2.1	—	Vrms	THD=1%, $B_w=400\sim 30\text{kHz}$
Residual noise voltage	V_{no}	—	4.5	15	μVrms	$R_g=0$, $V_{ol}=-\bullet$, $B_w=IHF-A$
Output residual noise voltage	V_{mno}	—	40	80	μVrms	$R_g=0$, $V_{ol}=0\text{dB}$, $B_w=IHF-A$
Volume control range	VRI	-90	-87	-84	dB	$V_{IN}=1\text{Vrms}$, 1dB/STEP
Bass control range	GB	+12 -16	+14 -14	+16 -12	dB	$V_{IN}=100\text{mVrms}$, 2dB/STEP
Treble control range	TB	+10 -14	+12 -12	+14 -10	dB	$V_{IN}=100\text{mVrms}$, 2dB/STEP
Surround gain (Antiphase)	V_{sur}	8	10	12	dB	$V_{IN}=100\text{mVrms}$

● Application Circuit

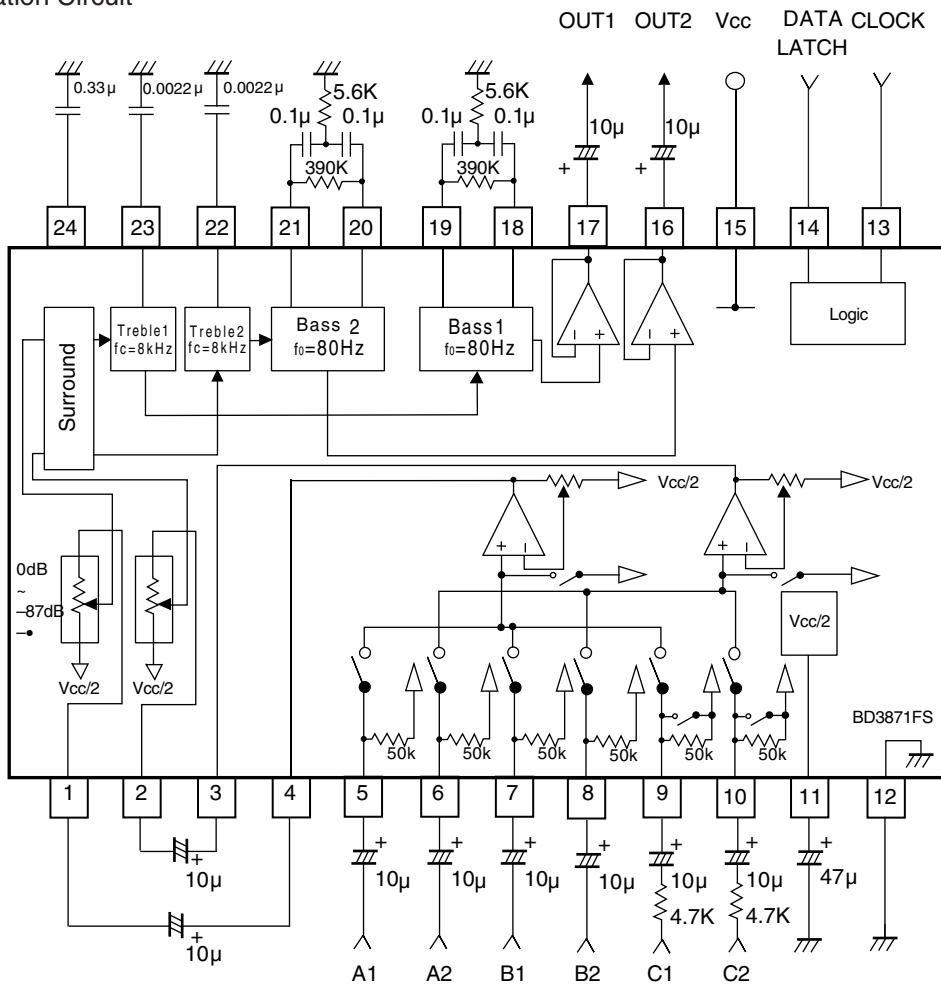

UNIT
 RESISTANCE :
 CAPACITOR : F

Notes

- No technical content pages of this document may be reproduced in any form or transmitted by any means without prior permission of ROHM CO.,LTD.
- The contents described herein are subject to change without notice. The specifications for the product described in this document are for reference only. Upon actual use, therefore, please request that specifications to be separately delivered.
- Application circuit diagrams and circuit constants contained herein are shown as examples of standard use and operation. Please pay careful attention to the peripheral conditions when designing circuits and deciding upon circuit constants in the set.
- Any data, including, but not limited to application circuit diagrams information, described herein are intended only as illustrations of such devices and not as the specifications for such devices. ROHM CO.,LTD. disclaims any warranty that any use of such devices shall be free from infringement of any third party's intellectual property rights or other proprietary rights, and further, assumes no liability of whatsoever nature in the event of any such infringement, or arising from or connected with or related to the use of such devices.
- Upon the sale of any such devices, other than for buyer's right to use such devices itself, resell or otherwise dispose of the same, no express or implied right or license to practice or commercially exploit any intellectual property rights or other proprietary rights owned or controlled by
- ROHM CO., LTD. is granted to any such buyer.
- Products listed in this document use silicon as a basic material.
Products listed in this document are no antiradiation design.

The products listed in this document are designed to be used with ordinary electronic equipment or devices (such as audio visual equipment, office-automation equipment, communications devices, electrical appliances and electronic toys).

Should you intend to use these products with equipment or devices which require an extremely high level of reliability and the malfunction of which would directly endanger human life (such as medical instruments, transportation equipment, aerospace machinery, nuclear-reactor controllers, fuel controllers and other safety devices), please be sure to consult with our sales representative in advance.

About Export Control Order in Japan

Products described herein are the objects of controlled goods in Annex 1 (Item 16) of Export Trade Control Order in Japan.

In case of export from Japan, please confirm if it applies to "objective" criteria or an "informed" (by MITI clause) on the basis of "catch all controls for Non-Proliferation of Weapons of Mass Destruction.