

TOSHIBA BIPOLAR LINEAR INTEGRATED CIRCUIT SILICON MONOLITHIC

TA8044AF

3.3V / 5V DUAL-VOLTAGE REGULATOR WITH WATCHDOG TIMER

Designed specifically for use in 3.3V microcomputers, this IC contains two constant-voltage power supplies for 3.3V and 5V uses and various system reset functions.

This IC's Power Supply Output 1 provides an output voltage of 3.4V and contains an output transistor capable of producing 10mA of output current. With an external boost transistor connected, this IC can supply a large output current. A 150mA current limiter is included.

Power Supply Output 2 provides an output voltage of 5.0V which can be turned on or off from the EN pin. This output uses an external output transistor. Any desired current limiter value can be set using an external adjusting resistor.

For a system reset, it has a low-voltage monitor / power-on reset / watchdog timer at Power Supply Output 2.

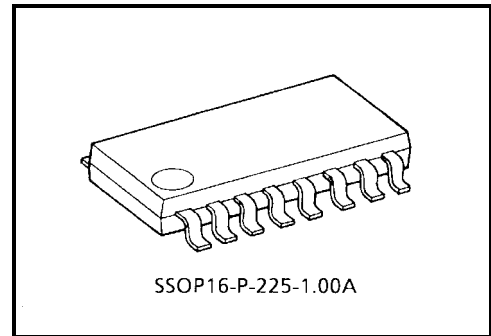

Weight: 0.14 g (typ.)

FEATURES

- Power Supply Output 1
 - Output voltage : 3.4V±0.15V
 - Output current : 10mA (built-in transistor) / 300 mA (when current boost transistor connected)
 - Current limiter : 150mA
- Power Supply Output 2
 - Output voltage : 5.0V (-0.18V to +0.15V)
 - Output current : 600mA (External transistor)
 - Current limiter : Variable using external adjusting resistor
- Reset functions : Low-voltage monitor and power-on watchdog timer
- Low standby current : 800µA (Max)
- Wide operating temperature range : -40°C to 125°C
- Compact flat package SSOP-16pin : 16-pin SSOP

BLOCK DIAGRAM AND PIN ASSIGNMENT

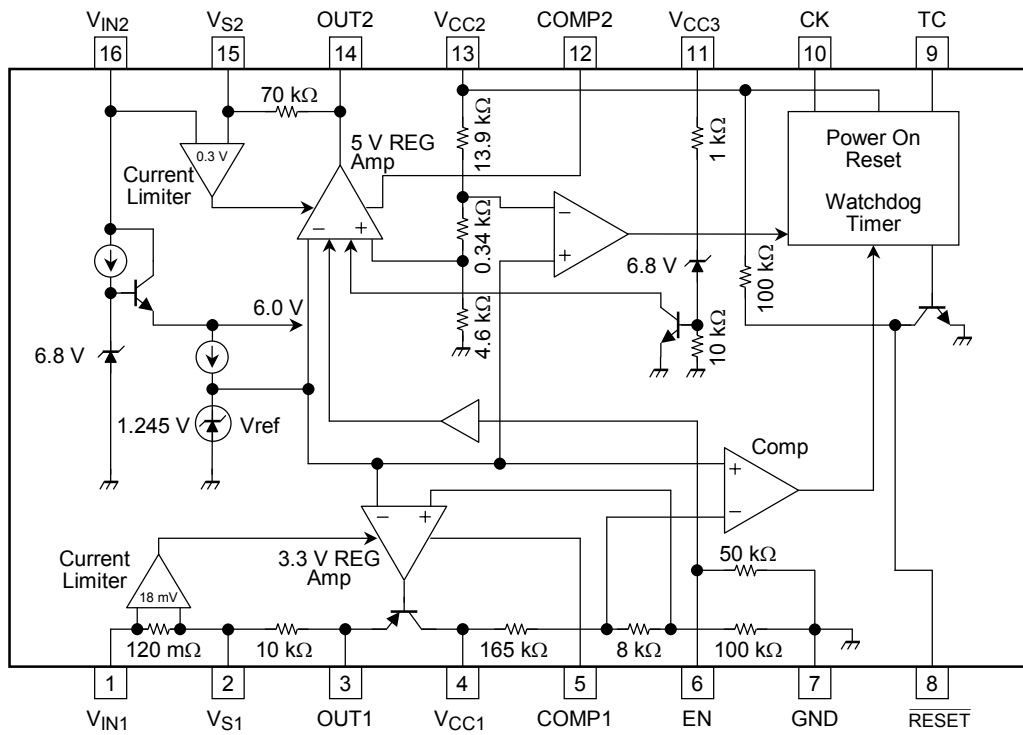

PIN DESCRIPTION

PIN No.	SYMBOL	DESCRIPTION
1	V _{IN1}	Power supply input pin for V _{CC1} . It contains a 150mA (Typ.) current limiter.
2	V _{S1}	Current limiter pin for V _{CC1} . A 120mΩsense resistor is included between pin 1 and this pin.
3	OUT1	Power supply input pin for V _{CC1} . When using an external current boost transistor, connect the base of a PNP transistor to this pin. No external transistor is required when using the IC at a load current of 10mA or less. In this case, connect the power supplies by shorting pins 1, 2, and 3.
4	V _{CC1}	Voltage detection / output pin for V _{CC1} . When using a current boost transistor, connect the collector of a PNP transistor to this pin. When used with a load current of 10mA or less, this pin serves as an output pin for the 3.3V power supply.
5	COMP1	Phase compensating pin for V _{CC1} . Connect a phase compensating capacitor between pin 4 and this pin.
6	EN	On / off control pin for V _{CC2} . The 5V output is turned on when EN is high and turned off when EN is low. A 50kΩ pull-down resistor is included in GND.
7	GND	Grounded
8	$\overline{\text{RESET}}$	Power-on reset / watchdog timer reset output pin. <ul style="list-style-type: none"> • Generates a reset signal that is determined by C_T and R_T at the TC pin. • If no clock is fed to the CK input, this pin generates a reset pulse intermittently. This is an NPN transistor collector output, with a 100kΩ pull-up resistor built into V _{CC2} .
9	TC	Time setup pin for the reset and watchdog timers. Connect resistor R _T to V _{CC2} and capacitor C _T to GND.
10	CK	Clock input pin for the watchdog timer. If used only as a power-on reset timer, pull up this input to V _{CC2} .
11	V _{CC3}	This pin contains a 7.5V Zener diode. To use this pin, short it to pin 13. When the V _{CC2} voltage becomes abnormal, the Zener diode suppresses the voltage.
12	COMP2	Phase compensating pin for V _{CC2} . Connect a phase compensating capacitor between pin 13 and this pin.
13	V _{CC2}	Voltage detection pin for the 5V constant-voltage power supply, V _{CC2} . It also supplies power to the reset timer block.
14	OUT2	This pin is used to connect the base of an external PNP transistor. The output voltage is controlled by an internal op-amp to maintain it stably at 5V. Since the recommended current of I _{OUT} is 5mA, an output current of up to 600mA can be flowed if HFE of the external transistor is 120 or more.
15	V _{S2}	Detection pin for the V _{CC2} current limiter. A voltage drop occurring in the external resistor R _s between pins 15 and 16 is monitored. The current limiter is actuated when the voltage drop exceeds 0.3V. Ex.) When the current limiter need to be actuated at a load current of 600mA $R_s = 0.3V / 600mA = 0.5\Omega$
16	V _{IN2}	Power supply input pin. An internal 6V constant voltage is connected to this pin for supplying power to the V _{CC1} / 2 current limiters, voltage regulating circuit for V _{CC1} , reference voltage source, and the EN input circuit.

TIMING CHART

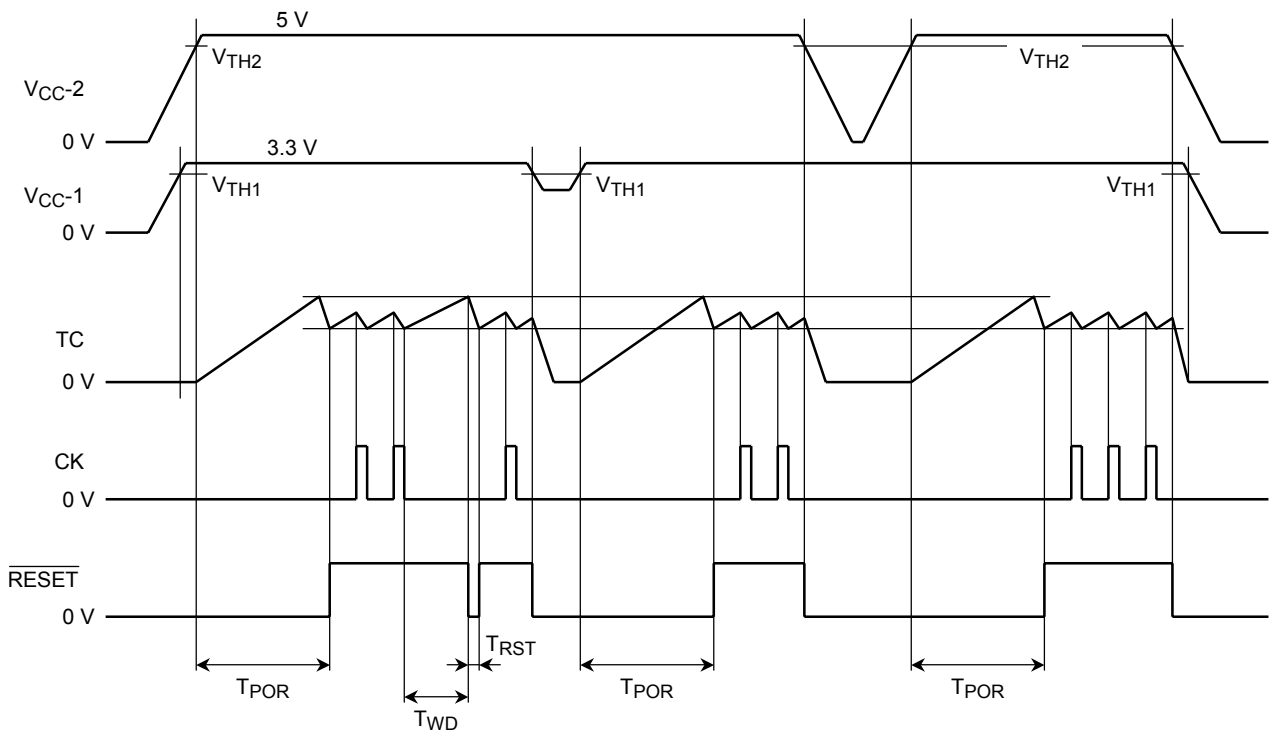

Note: See Electrical Characteristics for symbols in the timing chart.

MAXIMUM RATINGS (Ta = 25°C)

CHARACTERISTIC	SYMBOL	RATING	UNIT
Input Voltage	V _{IN}	60 (1s)	V
Output Current	I _{OUT1}	10	mA
	I _{OUT2}	10	
Operating Temperature	T _{opr}	-40~125	°C
Storage Temperature	T _{stg}	-55~150	°C
Lead Temperature-Time	T _{sol}	260 (10s)	°C

SSOP16- P-225 HEAT RESISTANCE DATA (Ta = 25°C)

CHARACTERISTIC	RATING	CONDITION	UNIT
R _{θj-a}	330	Single unit	°C/W
R _{θj-a}	160	50 × 50 × 1.6 mm 30%Cu	°C/W
P _{D1}	0.38	Single unit	W
P _{D2}	0.78	50 × 50 × 1.6 mm 30%Cu	W

ELECTRICAL CHARACTERISTICS ($V_{IN} = 6 \text{ to } 16\text{V}$, $I_{LOAD-1} = 10\text{mA}$, $I_{LOAD-2} = 10\text{mA}$, $T_a = -40\sim 125^\circ\text{C}$ unless otherwise specified)

CHARACTERISTIC	SYMBOL	PIN	TEST CIRCUIT	TEST CONDITION	MIN	TYP.	MAX	UNIT
Output Voltage	V _{REG-1}	V _{CC-1}	—	T _a = -40~105°C	3.28	3.4	3.52	V
			—	T _a = -40~125°C	3.25	3.4	3.55	
	V _{REG-2}	V _{CC-2}	—	T _a = -40~105°C	4.85	5.0	5.15	
			—	T _a = -40~125°C	4.82	5.0	5.15	
Input Stability	V _{LINE}	V _{CC-1/2}	—	V _{IN} = 6~40V	—	0.1	0.5	%
Load Stability	V _{LOAD-1}	V _{CC-1}	—	I _{LOAD} = 1~200mA	—	0.2	1.0	%
	V _{LOAD-2}	V _{CC-2}	—	I _{LOAD} = 1~300mA	—	0.2	1.0	
Temperature Coefficient		V _{CC-1/2}	—		—	0.01	—	% / °C
Input Current	I _{IN}	EN	—	V _{IN} =5V	—	0.1	0.2	mA
Input Voltage	V _{IH}	EN	—		2	—	—	V
	V _{IL}		—		—	—	0.8	
Output Voltage	V _{OL}	RESET	—	I _{OL} = 2mA	—	—	0.3	V
Output Leakage Current	I _{LEAK}	RESET	—	V _{IN} = V _{CC2}	—	—	5	μA
Input Current	I _{IN}	TC	—	V _{IN} = 0~3.5V	-3	—	3	μA
Threshold Voltage	V _{IH}	TC	—		—	4	—	V
	V _{IL}		—		—	2	—	
Input Current	I _{IN}	CK	—	V _{IN} = 5V	—	0.18	0.35	mA
Input Voltage	V _{IH}	CK	—		2	—	—	V
	V _{IL}		—		—	—	0.5	
Current Limiter	I _{LIMIT}	V _{CC-1}	—		—	150	—	mA
Current Limiter Detection	V _{LIMIT}	V _{CC-2}	—		—	0.3	—	V
Standby Current	I _{ST}		*1	V _{IN} = 14V, EN = "L"	—	400	800	μA
Current Consumption	I _{CC}		*1	V _{IN} = 14V, EN = "H"	—	3	5	mA
Reset Detection Voltage	V _{TH1}	V _{CC-1}	—		3.0	3.15	3.3	V
	ΔV _{TH1}		—	V _{CC-1} -V _{TH1}	0.2	0.25	0.3	
	V _{TH2}	V _{CC-2}	—		4.5	4.7	4.87	
	ΔV _{TH2}		—	V _{CC-2} -V _{TH2}	0.25	0.30	0.35	
Power-on Reset	T _{POR}	RESET	—		1.3× C _T ×R _T	1.6× C _T ×R _T	1.9× C _T ×R _T	ms
Watchdog Timer	T _{WD}	RESET	—		0.9× C _T ×R _T	1.1× C _T ×R _T	1.3 × C _T ×R _T	
Reset Timer	T _{RST}	RESET	—		0.3× C _T	0.7× C _T	1.5× C _T	
Clock Pulse Width	T _W	CK	—		3	—	—	μs

Note1: The unit for C_T is μF, the unit for R_T is kΩ.

*1 See EXAMPLE OF APPLICATION CIRCUIT(1)

Note2: The specification values of power-on reset, watchdog timer and reset timer above are intended to guarantee the IC itself. Note that the fluctuations of C_T and R_T values should be taken into consideration for practical use of the IC.

EXAMPLE OF APPLICATION CIRCUIT (1) Built-in 3.3V power supply +5V power supply

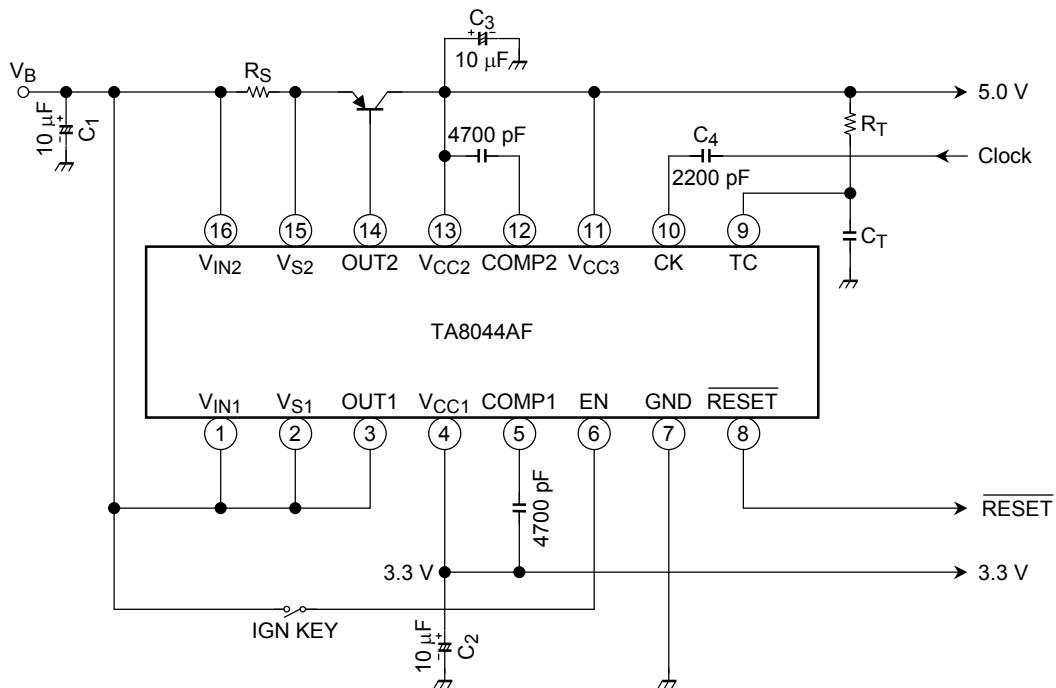

EXAMPLE OF APPLICATION CIRCUIT (2) 3.3V power supply with current boost transistor +5V power supply, 5V / 3V series connected

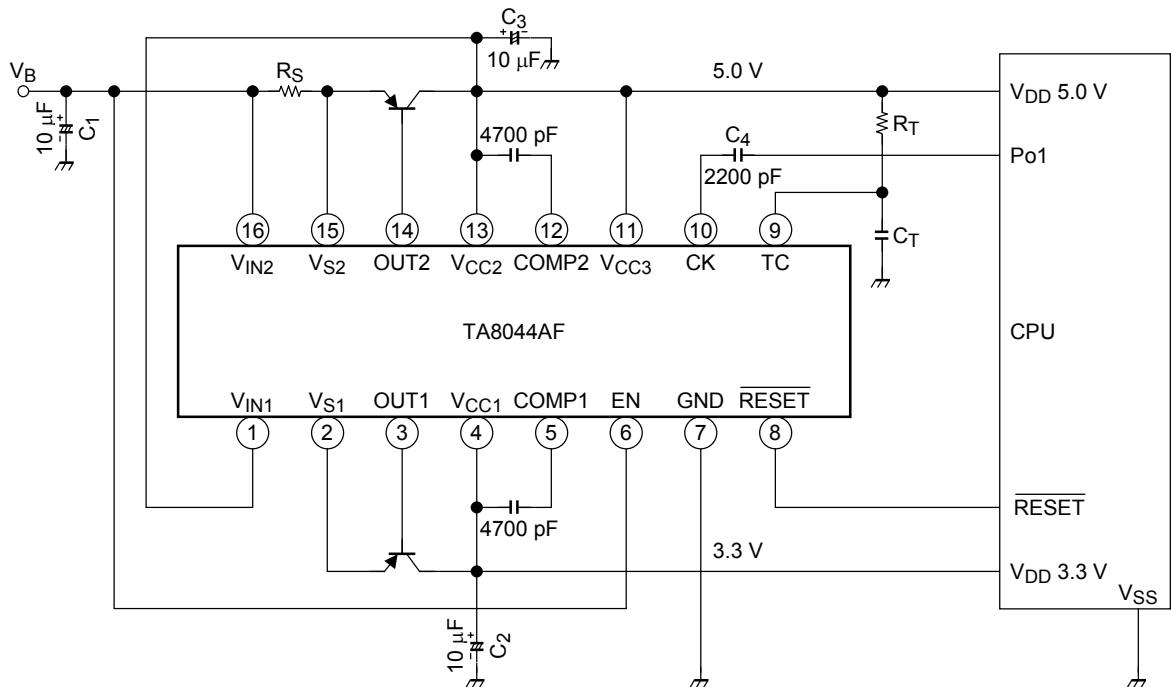

EXAMPLE OF APPLICATION CIRCUIT (3)

3.3V power supply with current boost transistor +5V power supply, 5V / 3V parallel connected

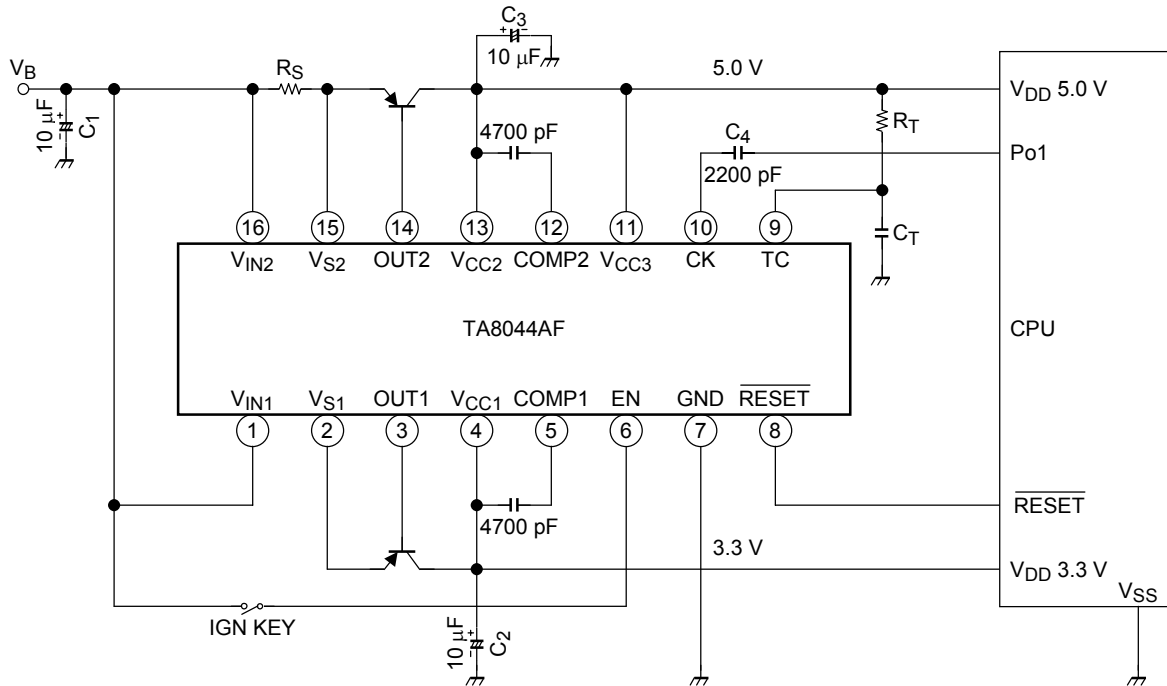

RECOMMENDED CONDITIONS

PART NAME	MIN	MAX	UNIT
C _T	0.01	100	μF
R _T	5	100	kΩ

APPLICATION CIRCUIT FOR CK INPUT

Capacitor Coupling

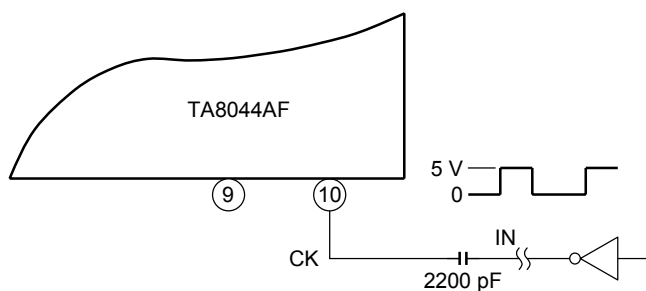

Timing Chart

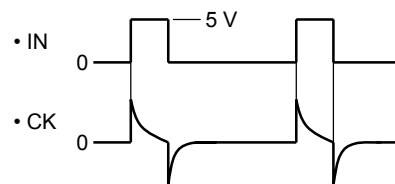

The capacitor coupling allows reset pulses to be supplied intermittently from the $\overline{\text{RESET}}$ pin whether the input level (IN) is high or low.

PACKAGE DIMENSIONS

SSOP16-P-225-1.00A

Unit : mm

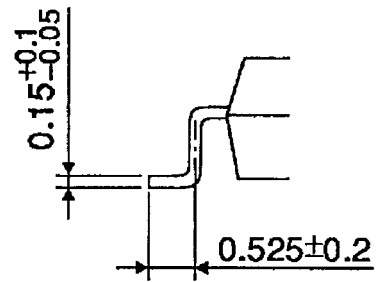
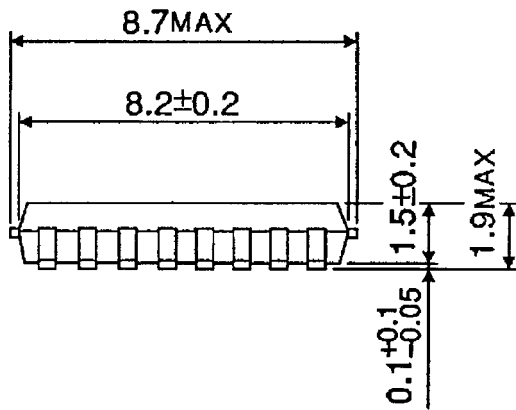
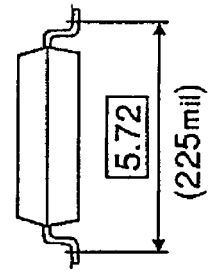
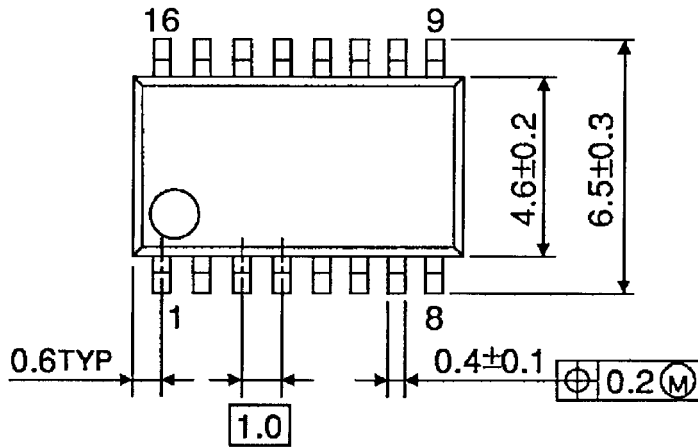

Weight: 0.14g (Typ.)

RESTRICTIONS ON PRODUCT USE

000707EAA_S

- TOSHIBA is continually working to improve the quality and reliability of its products. Nevertheless, semiconductor devices in general can malfunction or fail due to their inherent electrical sensitivity and vulnerability to physical stress. It is the responsibility of the buyer, when utilizing TOSHIBA products, to comply with the standards of safety in making a safe design for the entire system, and to avoid situations in which a malfunction or failure of such TOSHIBA products could cause loss of human life, bodily injury or damage to property.
In developing your designs, please ensure that TOSHIBA products are used within specified operating ranges as set forth in the most recent TOSHIBA products specifications. Also, please keep in mind the precautions and conditions set forth in the "Handling Guide for Semiconductor Devices," or "TOSHIBA Semiconductor Reliability Handbook" etc..
- The information contained herein is presented only as a guide for the applications of our products. No responsibility is assumed by TOSHIBA CORPORATION for any infringements of intellectual property or other rights of the third parties which may result from its use. No license is granted by implication or otherwise under any intellectual property or other rights of TOSHIBA CORPORATION or others.
- The information contained herein is subject to change without notice.