

Reversible motor driver

BA6950FS

The BA6950FS is a reversible-motor driver suited for brush motors. Two logic inputs allow four output modes: forward, reverse, stop (standby), and brake. The rotational speed of motor can be set arbitrarily by changing the voltage applied to the motor with control pins. The IC can also drive a motor at a constant speed by using a built-in current feedback amplifier.

●Applications

VCRs, audio equipment

●Features

- 1) Two logic inputs allow four output modes: forward, reverse, stop (standby), and brake.
- 2) Motor speed variable with voltage control signals.
- 3) Built-in current feedback amplifier allows constant motor speed.
- 4) Control gain can be set arbitrarily by using external resistors.
- 5) Built-in thermal shutdown circuit.

●Absolute maximum ratings (Ta = 25°C)

Parameter	Symbol	Limits	Unit
Applied voltage	V _{CC}	8	V
Applied voltage	V _B	18	V
Power dissipation	P _d	800* ¹	mW
Operating temperature	T _{opr}	-20~+75	°C
Storage temperature	T _{stg}	-55~+150	°C
Output current	I _{OUT}	400* ²	mA

*1 When mounted on a glass epoxy board (90 × 50 × 1.6 mm).
Reduced by 6.4 mW for each increase in Ta of 1 °C over 25°C.

*2 Should not exceed Pd or ASO values.

●Recommended operating conditions (Ta = 25°C)

Parameter	Symbol	Range	Unit
Operating power supply voltage	V _{CC}	3~6	V
	V _B	3~16	V
	V _{CTL}	0~(V _{CC} -1.8V)	V

● Block diagram

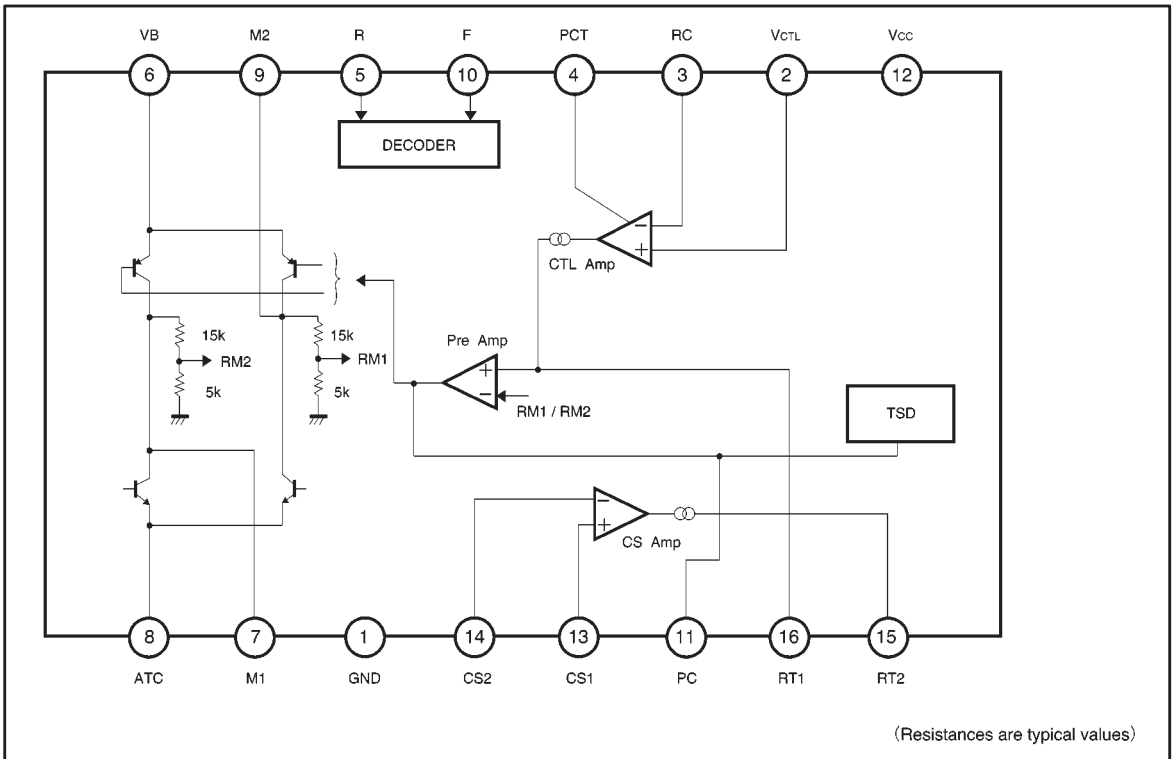

● Pin descriptions

Pin No.	Pin name	Function
1	GND	GND
2	V _{ctl}	Control signal input
3	RC	Resistor connection for control gain setting
4	PCT	Capacitor connection for control phase compensation
5	R _{IN}	Logic input
6	VB	Driver power supply
7	M1	Motor output
8	ATC	Resistor connection for output current detection
9	M2	Motor output
10	F _{IN}	Logic input
11	PC	Capacitor connection for current feedback phase compensation
12	V _{cc}	Signal power supply
13	CS1	Resistor connection for CSAMP gain setting
14	CS2	Resistor connection for CSAMP gain setting
15	RT2	Resistor connection for control gain setting
16	RT1	Resistor connection for control gain setting

● Input/output circuit (resistances, in Ω , are typical values)

(1) R and F inputs (pins 5 and 10)

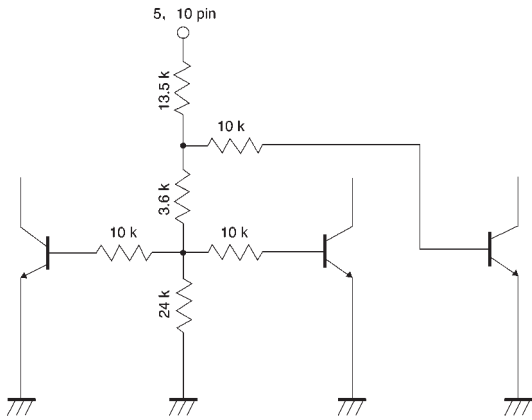

Fig.1

(3) Motor output (pins 6, 7, 8, and 9)

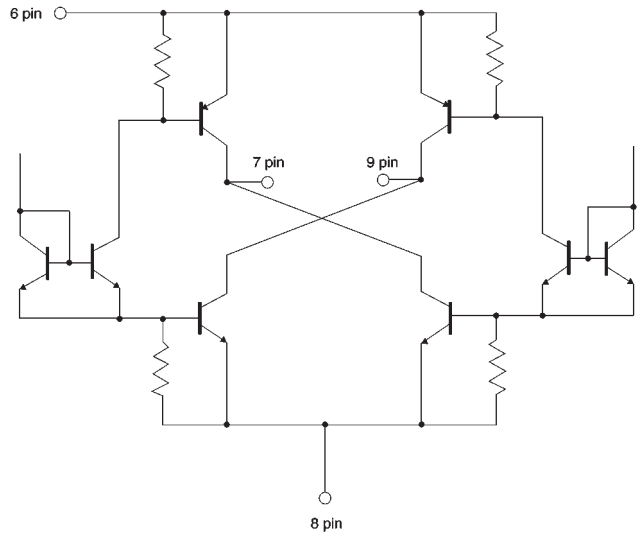

Fig.3

(2) CTL amplifier (pins 2 and 3)

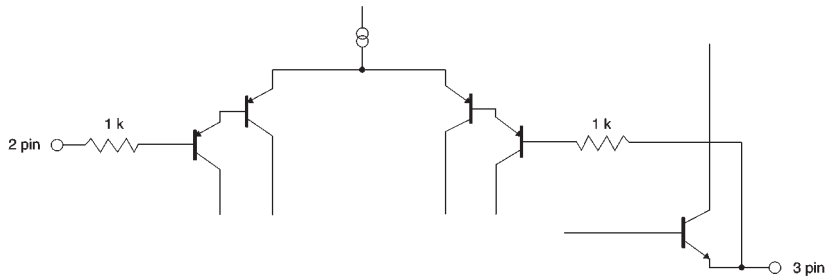

Fig.2

●Electrical characteristics (unless otherwise noted, Ta = 25°C, V_{CC} = 4.8V, V_B = 4.8V)

Parameter	Symbol	Min.	Typ.	Max.	Unit	Conditions
Supply current 1	I _{CC1}	—	4.0	6.0	mA	(R _{IN} , F _{IN}) = (L, H) or (H, L), V _{CTL} =0V
Supply current 2	I _{CC2}	—	0.7	1.5	mA	(R _{IN} , F _{IN}) = (L, L), V _{CTL} =0V
Supply current 3	I _{Boff}	—	0	1.0	μA	IB when V _{CC} = 0 V
HIGH level R / F voltage	V _{R/FH}	2.0	—	—	V	
LOW level R / F voltage	V _{R/FL}	—	—	0.8	V	
Input high level current	I _{R/FH}	—	80	135	μA	R _{IN} =2V, F _{IN} =2V
CTL amplifier offset	V _{CTL ofs}	-5.0	—	+5.0	mV	(V _{CTL} - RC) when V _{CTL} = 0 V, 1 V
CTL amplifier gain	V _{CTL Ga}	40	46	52	μA / V	ΔI _{RT1} / 1 when V _{CTL} = 2 V, 1 V
CTL output mirror ratio 1	I _{CTLR1}	0.85	1	1.15	ratio	I _{RT1} / I _{RC} when I _{RC} = 20 μA
CTL output mirror ratio 2	I _{CTLR2}	0.90	1	1.10	ratio	I _{RT1} / I _{RC} when I _{RC} = 200 μA
CS amplifier offset	CS ofs	-5.0	—	+5.0	mV	(CS1 - CS2) when CS1 = 0 V, 0.1 V
CS output mirror ratio 1	I _{CSR1}	0.85	1	1.15	ratio	I _{RT2} / I _{CS2} when I _{CS2} = 20 μA
CS output mirror ratio 2	I _{CSR2}	0.90	1	1.10	ratio	I _{RT2} / I _{CS2} when I _{CS2} = 200 μA
Output high level voltage	V _H	2.0	4.6	—	V	M1, M2 voltage when V _{CTL} = 0.2 V
Low-side output saturation voltage	V _{OL}	—	0.07	0.2	V	RT1 = V _{CC} when I _o = 50mA
High-side output saturation voltage	V _{OH}	—	0.09	0.3	V	RT1 = V _{CC} when I _o = 50mA

©Not designed for radiation resistance.

●Circuit operation

(1) Input section (F_{IN}, R_{IN})

Control signals are input from these pins. Current flows from M2 to M1 (forward mode) when F_{IN} is HIGH and R_{IN} is LOW, and from M1 to M2 (reverse mode) when R_{IN} is HIGH and F_{IN} is LOW. Putting F_{IN} and R_{IN} both HIGH results in the brake mode in which the high-side output transistor is turned off to shut down the motor driving current and the low-side output transistor is turned ON to absorb the counter-electromotive force of the motor, so that a brake is put on the motor. When F_{IN} and R_{IN} are both LOW, both M1 and M2 are left open and the motor stops. Input/output truth table

F _{IN}	R _{IN}	M1	M2	Mode
H	L	L	H	Forward
L	H	H	L	Reverse
H	H	L	L	Brake
L	L	OPEN		Standby

(2) Output section (M1, M2)

Two logic inputs control the motor by changing the status of bridge-configured transistors.

(3) Output high level voltage

Values of current, voltage, and HIGH level output voltage can be set as follows by using external resistors (refer to the application circuit of Fig. 4).

- I16 pin (I_{RT1})
I16 pin (I_{RT1}) = V2 pin/R1 ... ①
- I15 pin (I_{RT2})
I15 pin (I_{RT2}) = I8 pin × R5/R4 ... ②
- V16 pin (V_{RT1})
V16 pin = R3 × (I16 pin + I15 pin) + R2 × I16 pin ... ③
- V7, 9 pin (M1, M2 voltage; high-side voltage)
V7, 9 pin = 4 × V16 pin (Typ.) ... ④

(4) Current feedback amplifier

The pin-8 current is increased when the motor rotational speed is reduced by loading, and the current feedback amplifier increases the pin-15 current according to equation ②. Because the pin-16 voltage then increases according to equation ③, the HIGH level output voltage also increases according to equation ④. In this way, the rotational speed is kept constant by increasing the voltage applied to the motor.

●Application example

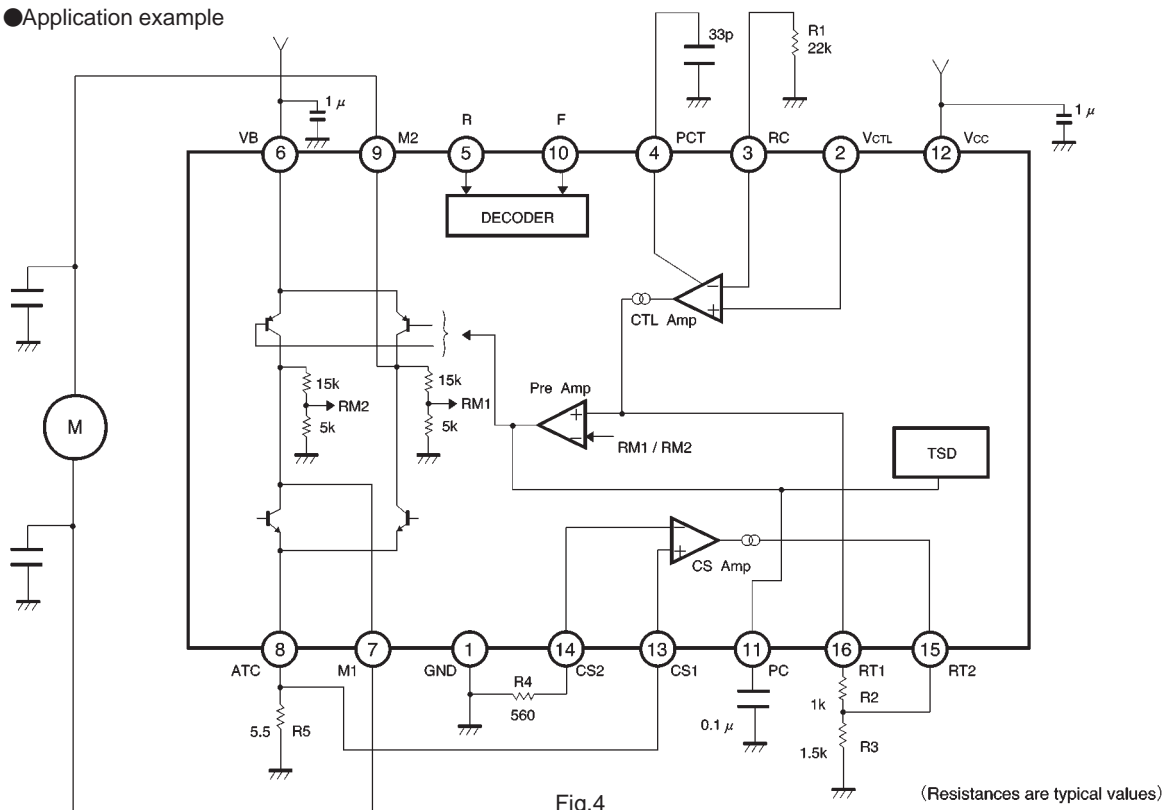

Fig.4

●Operation notes

(1) Thermal shutdown circuit

The thermal shutdown (TSD) circuit turns off all driver outputs when the IC junction temperature rises above 175°C (Typ.). The temperature difference between the activation and deactivation settings is about 20°C.

•Temperature setting of TSD

	Min.	Typ.	Max.	Unit
TSD activation temperature	150	175	200	°C
Hysteresis width	—	20	—	°C

(2) Control logic and control signal input pins

Voltage should never be applied to the control logic input pins (pins 5 and 10) or the control signal input pin (pin 2) when the V_{CC} voltage is not applied to the IC. Similarly, the voltage on each input pin should not exceed any applied V_{CC} voltage.

(3) PCB arrangement

When changing the rotational direction of a motor, a large

current of up to a few hundred milliamperes can flow between the motor power supply (pin 6) and RNF (pin 8). Depending on the application, this large output current may flow back to input pins, resulting in output oscillation or other malfunctions. Make sure that your design does not allow a common impedance between the large current output lines and the input section. Suppress the power supply impedance to low levels, otherwise output oscillation may occur.

(4) Package power

The power dissipated by the IC varies widely with the supply voltage and the output current. Give full consideration to the package power dissipation rating when setting the supply voltage and the output current.

(5) The input pins (pins 5 and 10) have temperature-dependent characteristics. Take the temperature effect into consideration when using the IC.

(6) To eliminate motor noise, connect a capacitor between M1 (pin 7) and GND and between M2 (pin 9) and GND.

●Electrical characteristic curves

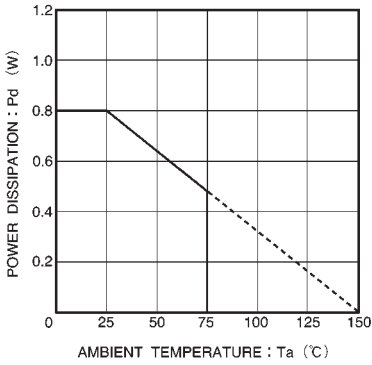

Fig.5 Temperature dependence of power dissipation

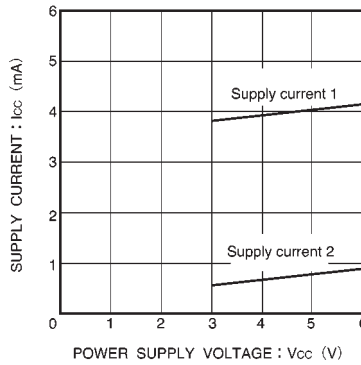

Fig.6 Supply current vs. power supply voltage

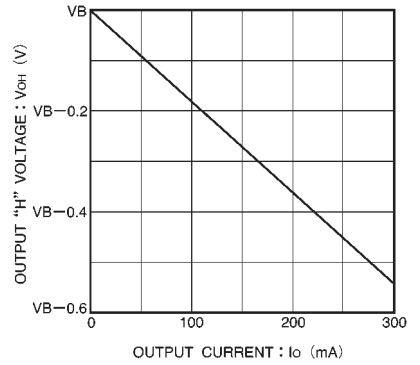

Fig.7 Output high level voltage vs. output current

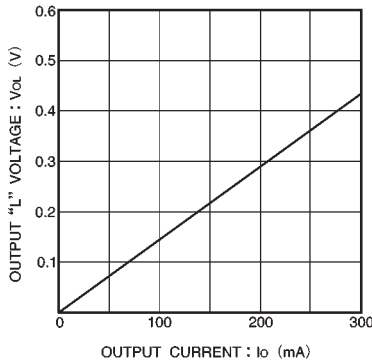

Fig.8 Output low level voltage vs. output current

●External dimensions (Units: mm)

