

Features

- 80C51-compatible CPU Core High-speed Architecture
- 16 MHz at 3.3V
- X2 Speed Improvement Capability (6 Clocks/Machine Cycle)
- 256 Bytes RAM
- 256 Bytes XRAM
- 12 Kbytes ROM/OTP Program Memory
- Two 16-bit Timer/Counters T0, T1
- 5 Channels Programmable Counter Array with High-speed Output, Compare/Capture, Pulse Width Modulation and Watchdog Timer Capabilities
- 2 MHz SPI Serial Interface
- Interrupt Structure with:
 - 5 Interrupt Sources
 - 4 Interrupt Priority Levels
- Power Supply: 3 - 5V $\pm 10\%$
- Temperature Range: Industrial (-40°C to 85°C), Automotive (-40°C to 125°C)
- Package: SSOP16, SSOP24

Description

The AT8xC5103 is a high-performance ROM/OTP version of the 80C51 8-bit Microcontroller in 16 and 24-pin packages.

The AT8xC5103 contains a standard C51 CPU core with 12 Kbytes ROM/OTP program memory, 256 bytes of internal RAM, 256 bytes of extended internal RAM, a 5-sources 4-level interrupt system, two timer/counters and a SPI serial bus controller.

The AT8xC5103 is also dedicated for analog interfacing applications. For this, it has a five channels Programmable Counter Array.

In addition, the AT8xC5103 implements the X2 speed improvement mechanism. The X2 feature allows to keep the same CPU power at a divided by two oscillator frequency.

The fully static design of the AT8xC5103 allows to reduce system power consumption by bringing the clock frequency down to any value, even DC, without loss of data.



Low-pin Count 8-bit Microcontroller

AT87C5103

AT83C5103

Preliminary

Block Diagram

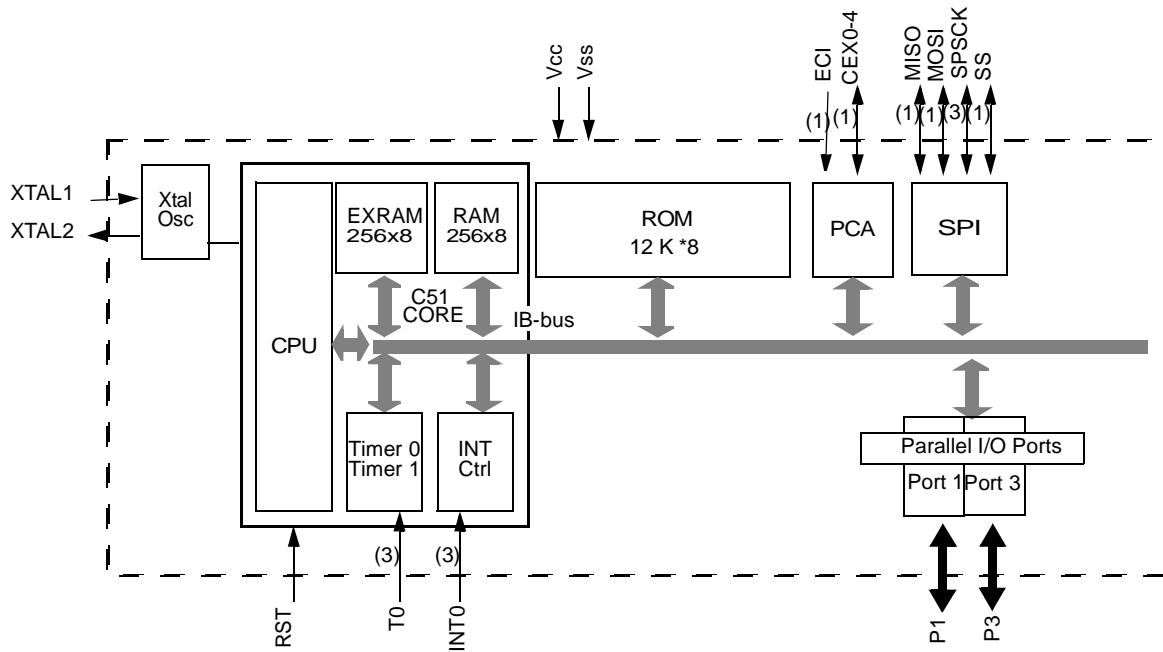

- Notes:
1. Alternate function of Port 1.
 2. Alternate function of Port 3.

Pin Configurations

SSOP16

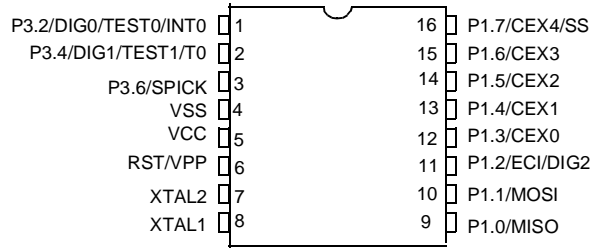

SSOP24

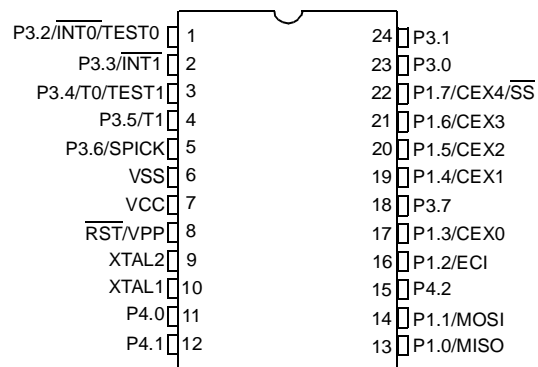

Pin Description

Mnemonic	Type	Name And Function
V _{SS}	I	Ground: 0V reference
V _{CC}	I	Power Supply: 3.3V
P1.0 - P1.7	I/O	Port 1: Port 1 is an 8-bit programmable I/O port with internal pull-up Alternate functions for Port 1 include:
	I/O	MISO (P1.0): Master IN, Slave OUT of the SPI controller
	I/O	MOSI (P1.1): Master OUT, Slave IN of the SPI controller
	I/O	DIG2 (P1.2): Programmable as Output with Push-pull ECI: External Clock for PCA
	I/O	CEX0 (P1.3): Capture/Compare External I/O for PCA module 0
	I/O	CEX1 (P1.4): Capture/Compare External I/O for PCA module 1
	I/O	CEX2 (P1.5): Capture/Compare External I/O for PCA module 2
	I/O	CEX3 (P1.6): Capture/Compare External I/O for PCA module 3
	I/O	SS (P1.7): Slave select input of the SPI controller CEX4: Capture/Compare External I/O for PCA module 3
XTAL1	I	Input to the inverting oscillator amplifier
XTAL2	O	Output from the inverting oscillator amplifier
RST/VPP	I	RST: Negative Reset input A low on this pin for two machine cycles while the oscillator is running, resets the device. This pin will include a pull-down to reset the circuit if no external reset level is applied (AMDEC) VPP: High voltage input for OTP programming
P3.0 - P3.7	I/O	Port 3: Port 3 is a 3-bit programmable I/O port with internal pull-up.
	I/O	DIG0 (P3.2): Programmable as Output with Push-pull. INT0: External Interrupt 0 During active reset, this pin is TEST0 used for low-pin count testing
	I/O	DIG1 (P3.4): Programmable as Output with Push-pull. T0: Timer 0 external Input During active reset, this pin is TEST1 used for low-pin count testing
	I/O	SPICK (P3.6): Clock I/O of the SPI controller
P4.0-P4.2	I/O	Port 4: Port 4 is an 8-bit programmable I/O port with internal pull-up

SFR Mapping

The Special Function Registers (SFRs) of the AT8xC5103 belongs to the following categories:

- C51 core registers: ACC, B, DPH, DPL, PSW, SP, AUXR1
- I/O port registers: P1, P3, P1M1, P1M2, P3M1, P3M2
- Timer registers: TCON, TH0, TH1, TMOD, TL0, TL1
- Power and clock control registers: CKCON0, CKCON1, PCON
- Interrupt system registers: IE, IE1, IPL0, IPL1, IPH0, IPH1
- SPI: SPCON, SPSTA, SPDAT
- PCA: CCAP0L, CCAP1L, CCAP2L, CCAP3L, CCAP4L, CCAP0H, CCAP1H, CCAP2H, CCAP3H, CCAP4H, CCAPM0, CCAPM1, CCAPM2, CCAPM3, CCAPM4, CL, CH, CMOD, CCON



Table 1. SFR Addresses and Reset Values

	0/8	1/9	2/A	3/B	4/C	5/D	6/E	7/F	
F8h		CH 0000 0000	CCAP0H 0000 0000	CCAP1H 0000 0000	CCAP2H 0000 0000	CCAP3H 0000 0000	CCAP4H 0000 0000		FFh
F0h	B 0000 0000								F7h
E8h		CL 0000 0000	CCAP0L 0000 0000	CCAP1L 0000 0000	CCAP2L 0000 0000	CCAP3L 0000 0000	CCAP4L 0000 0000		EFh
E0h	ACC 0000 0000		P1M2 0000 0000		P3M2 X0X0 X0XX				E7h
D8h	CCON 00X0 0000	CMOD X000 0000	CCAPM0 00XX X000	CCAPM1 X000 0000	CCAPM2 X000 0000	CCAPM3 X000 0000	CCAPM4 X000 0000		DFh
D0h	PSW 0000 0000				P1M1 0000 0000	P3M1 X0X0 X0XX			D7h
C8h									CFh
C0h	P4 XXXX X111			SPCON 0001 0100	SPSTA XXXXXXXX	SPDAT XXXX XXXX			C7h
B8h	IPL0 X0XX 0X00								BFh
B0h	P3 X1X1 X1XX	IE1 XXXX X0XX	IPL1 XXXX X0XX	IPH1 XXXX X0XX				IPH0 X0XX 0X00	B7h
A8h	IE0 0000 0000							CKCON1 XXXX XXX0	AFh
A0h			AUXR1 XXXXXXXX0						A7h
98h									9Fh
90h	P1 1111 1111								97h
88h	TCON 0000 0000	TMOD 0000 0000	TL0 0000 0000	TL1 0000 0000	TH0 0000 0000	TH1 0000 0000		CKCON0 XX0X X000b	8Fh
80h		SP 0000 0111	DPL 0000 0000	DPH 0000 0000				PCON 00X1 0000	87h
	0/8	1/9	2/A	3/B	4/C	5/D	6/E	7/F	

Clock

The AT8xC5103 core needs only 6 clock periods per machine cycle. This feature, called "X2", provides the following advantages:

- Divides frequency crystals by 2 (cheaper crystals) while keeping the same CPU power.
- Saves power consumption while keeping the same CPU power (oscillator power saving).
- Saves power consumption by dividing dynamic operating frequency by 2 in operating and idle modes.
- Increases CPU power by 2 while keeping the same crystal frequency.

In order to keep the original C51 compatibility, a divider-by-2 is inserted between the XTAL1 signal and the main clock input of the core (phase generator). This divider may be disabled by the software.

An extra feature is available for selected hardware in the X2 Mode. This feature allows starting of the CPU in the X2 Mode, without starting in the standard mode.

The hardware CPU X2 Mode can be read and write via IAP (SetX2mode, ClearX2mode, ReadX2mode), see In-System Programming section.

These IAPs are detailed in the "In-System Programming" section.

Description

The clock for the whole circuit and peripheral is first divided by 2 before being used by the CPU core and peripherals. This allows any cyclic ratio to be accepted on the XTAL1 input. In X2 Mode, as this divider is bypassed, the signals on XTAL1 must have a cyclic ratio between 40 to 60%. Figure 1. shows the clock generation block diagram. The X2 bit is validated on the XTAL1 ÷ 2 rising edge to avoid glitches when switching from the X2 to the STD mode. Figure 2 shows the mode switching waveforms.

Figure 1. Clock CPU Generation Diagram

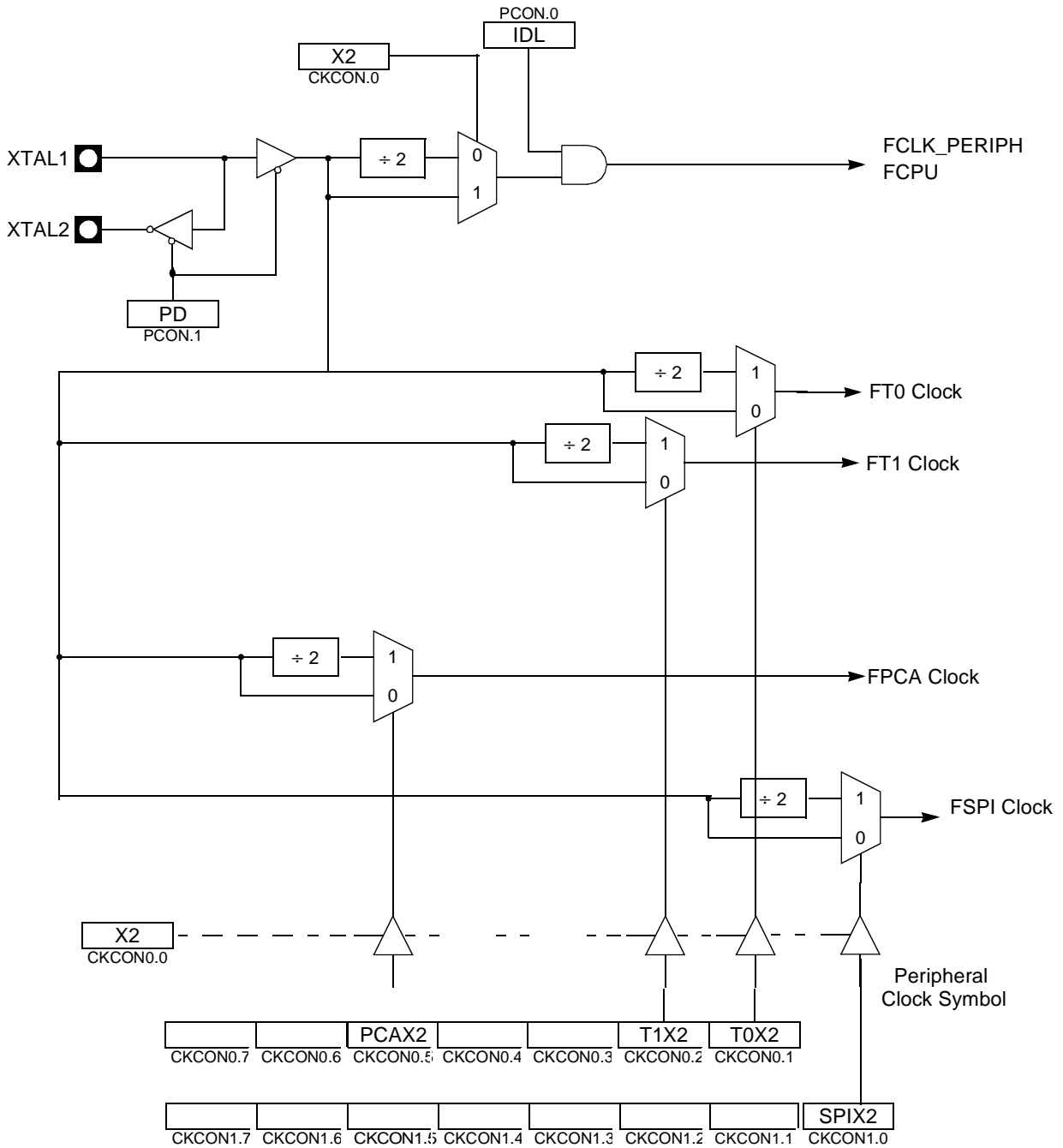
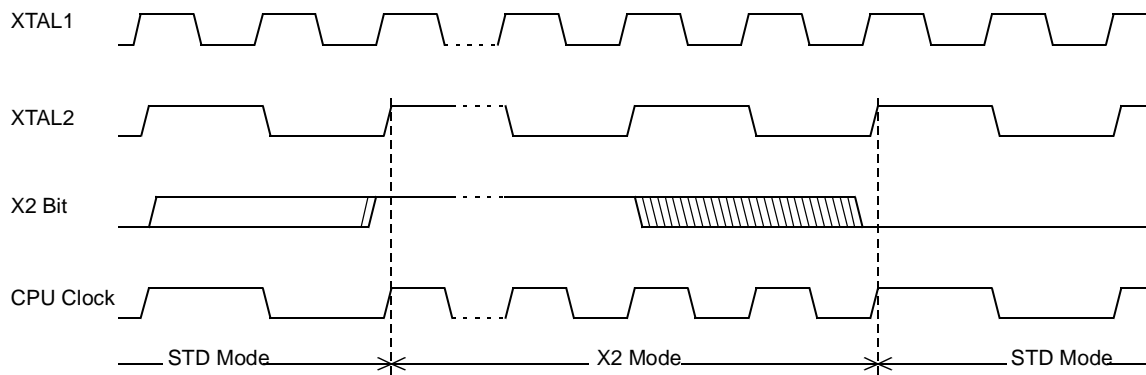

Figure 2. Mode Switching Waveforms



The X2 bit in the CKCON register (See Table 2) allows switching from 12 clock cycles per instruction to 6 clock cycles and vice versa. At reset, the standard speed is activated (STD mode). Setting this bit activates the X2 feature (X2 Mode).

Note: In order to prevent any incorrect operation while operating in the X2 Mode, users must be aware that all peripherals using the clock frequency as a time reference (timers, PCA, SPI) will have their time reference divided by 2. For example, a free running timer generating an interrupt every 20 ms will then generate an interrupt every 10 ms.

Registers

Table 2. CKCON0 Register
CKCON0 (S:8Fh)
Clock Control Register

7	6	5	4	3	2	1	0
		PCAX2			T1X2	T0X2	X2
Bit Number	Bit Mnemonic	Description					
7	–	Reserved The value read from this bit is indeterminate. Do not set this bit.					
6	–	Reserved The value read from this bit is indeterminate. Do not set this bit.					
5	PCAX2	Programmable Counter Array clock⁽¹⁾ Clear to select 6 clock periods per peripheral clock cycle. Set to select 12 clock periods per peripheral clock cycle.					
4	–	Reserved The value read from this bit is indeterminate. Do not set this bit.					
3	–	Reserved The value read from this bit is indeterminate. Do not set this bit.					
2	T1X2	Timer1 Clock⁽¹⁾ Clear to select 6 clock periods per peripheral clock cycle. Set to select 12 clock periods per peripheral clock cycle.					
1	T0X2	Timer0 Clock⁽¹⁾ Clear to select 6 clock periods per peripheral clock cycle. Set to select 12 clock periods per peripheral clock cycle.					
0	X2	CPU Clock Clear to select 12 clock periods per machine cycle (STD mode) for CPU and all the peripherals. Set to select 6 clock periods per machine cycle (X2 Mode) and to enable the individual peripherals "X2" bits.					

Notes: 1. This control bit is validated when the CPU clock bit X2 is set; when X2 is low, this bit has no effect.

Reset Value = XX0X X000b

Table 3. CKCON1 Register
 CKCON1 (S:AFh)
 Clock Control Register

7	6	5	4	3	2	1	0
							SPIX2
Bit Number	Bit Mnemonic	Description					
7	–	Reserved The value read from this bit is indeterminate. Do not set this bit.					
6	–	Reserved The value read from this bit is indeterminate. Do not set this bit.					
5	–	Reserved The value read from this bit is indeterminate. Do not set this bit.					
4	–	Reserved The value read from this bit is indeterminate. Do not set this bit.					
3	–	Reserved The value read from this bit is indeterminate. Do not set this bit.					
2	–	Reserved The value read from this bit is indeterminate. Do not set this bit.					
1	–	Reserved The value read from this bit is indeterminate. Do not set this bit.					
0	SPIX2	SPI clock ⁽¹⁾ Clear to select 6 clock periods per peripheral clock cycle. Set to select 12 clock periods per peripheral clock cycle.					

Notes: 1. This control bit is validated when the CPU clock bit X2 is set; when X2 is low, this bit has no effect.

Reset Value = XXXX XXX0b



Ports

The AT8xC5103 has 2 I/O ports, port 1 and port 3.

Except $\overline{\text{RST}}$, all port1 and port 3 I/O port pins on the AT8xC5103 may be software configured to one of four types on a bit-by-bit basis, as shown in Table 2. These are: quasi-bi-directional (standard 80C51 port outputs), push-pull, open drain, and input only. Two configuration registers for each port choose the output type for each port pin.

PxM1.y Bit	PxM2.y Bit	Port Output Mode
0	0	Quasi bi-directional
0	1	Push-pull
1	0	Input Only (High Impedance)
1	1	Open Drain

Port Types

Quasi-Bi-directional Output Configuration

The default port output configuration for standard AT8xC5103 I/O ports is the quasi-bi-directional output that is common on the 80C51 and most of its derivatives. This output type can be used as both an input and output without the need to reconfigure the port. This is possible because when the port outputs a logic high, it is weakly driven, allowing an external device to pull the pin low. When the pin is pulled low, it is driven strongly and able to sink a fairly large current. These features are somewhat similar to an open drain output except that there are three pull-up transistors in the quasi-bi-directional output that serve different purposes. One of these pull-ups, called the ‘very weak’ pull-up, is turned on whenever the port latch for the pin contains a logic 1. The very weak pull-up sources a very small current that will pull the pin high if it is left floating. A second pull-up, called the ‘weak’ pull-up, is turned on when the port latch for the pin contains a logic 1 and the pin itself is also at a logic 1 level. This pull-up provides the primary source current for a quasi-bi-directional pin that is outputting a 1. If a pin that has a logic 1 on it is pulled low by an external device, the weak pull-up turns off, and only the very weak pull-up remains on. In order to pull the pin low under these conditions, the external device has to sink enough current to overpower the weak pull-up and take the voltage on the port pin below its input threshold.

The third pull-up is referred to as the ‘strong’ pull-up. This pull-up is used to speed up low-to-high transitions on a quasi-bi-directional port pin when the port latch changes from a logic 0 to a logic 1. When this occurs, the strong pull-up turns on for a brief time, two CPU clocks, in order to pull the port pin high quickly. Then it turns off again.

The quasi-bi-directional port configuration is shown in Figure 3.

Figure 3. Quasi-Bi-directional Output

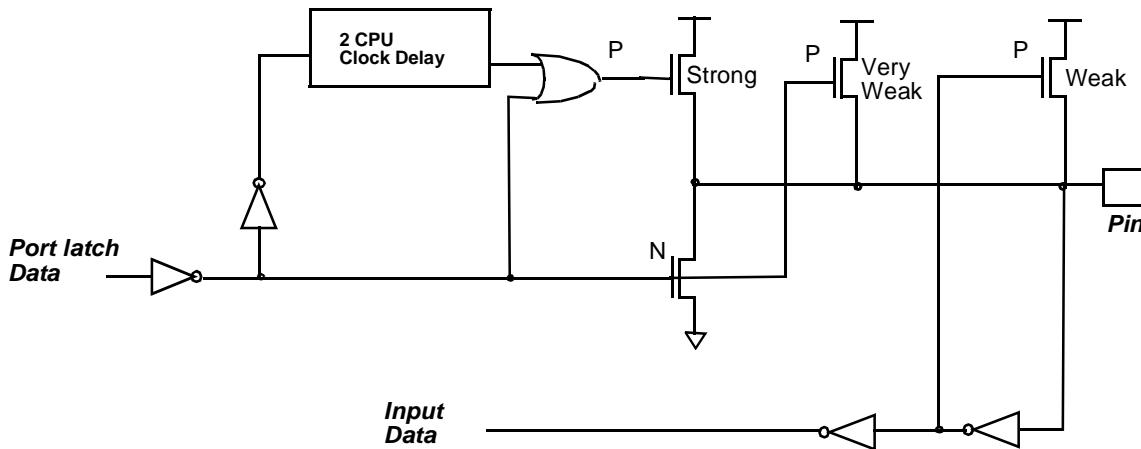

Open Drain Output Configuration

The open-drain output configuration turns off all pull-ups and only drives the pull-down transistor of the port driver when the port latch contains a logic 0. To be used as a logic output, a port configured in this manner must have an external pull-up, typically a resistor tied to V_{DD} . The pull-down for this mode is the same as for the quasi-bi-directional mode. The open drain port configuration is shown in Figure 4.

Figure 4. Open Drain Output

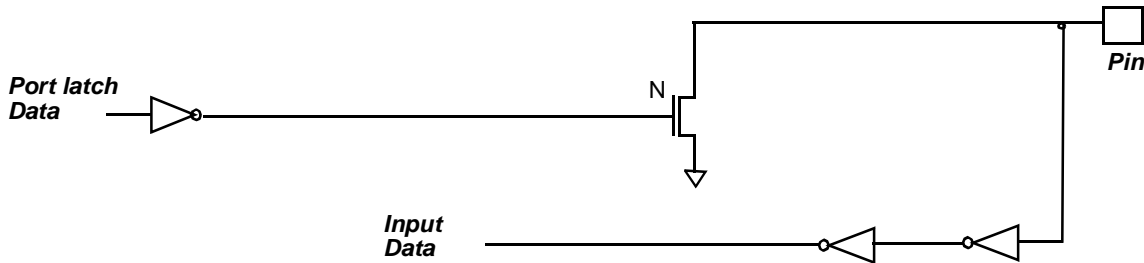

Push-Pull Output Configuration

The push-pull output configuration has the same pull-down structure as both the open drain and the quasi-bi-directional output modes, but provides a continuous strong pull-up when the port latch contains a logic 1. The push-pull mode may be used when more source current is needed from a port output. The push-pull port configuration is shown in Figure 5.

Figure 5. Push-pull Output

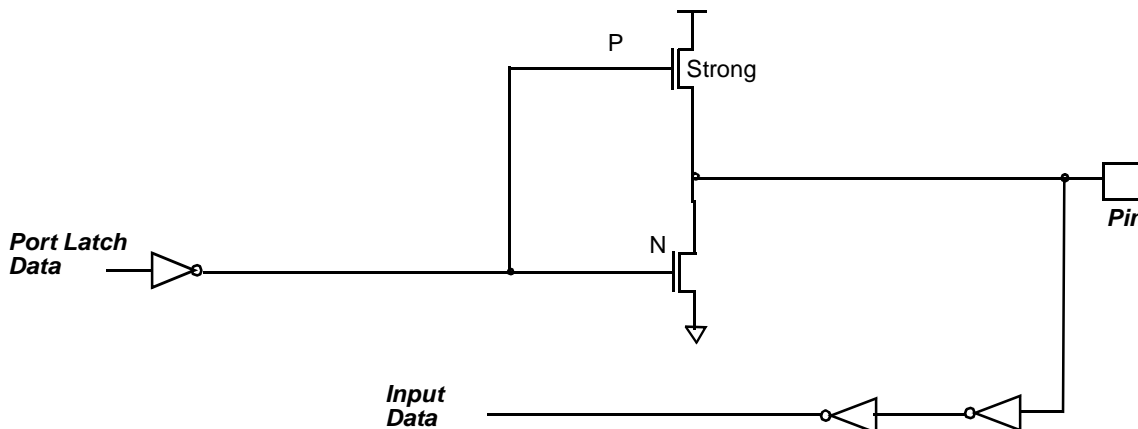

Input Only Configuration

The input only configuration is a pure input with neither pull-up nor pull-down. The input only configuration is shown in Figure 5.

Figure 6. Input Only

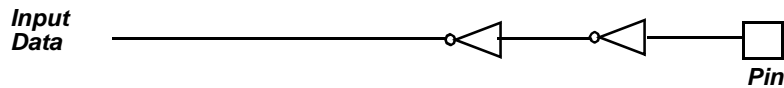

Ports Description

Ports P1 and P3

The inputs of each I/O port of the AT8xC5103 are TTL level Schmitt triggers with hysteresis.

Registers

Table 4. P1M1 Register
P1M1 Address (D4h)

7	6	5	4	3	2	1	0
P1M1.7	P1M1.6	P1M1.5	P1M1.4	P1M1.3	P1M1.2	P1M1.1	P1M1.0
Bit Number	Bit Mnemonic	Description					
7: 0	P1M1.x	Port Output configuration Bit See Table 2. for configuration definition					

Reset Value = 000 0000

Table 5. P1M2 Register
P1M2 Address (E2h)

7	6	5	4	3	2	1	0
P1M2.7	P1M2.6	P1M2.5	P1M2.4	P1M2.3	P1M2.2	P1M2.1	P1M2.0
Bit Number	Bit Mnemonic	Description					
7: 0	P1M2.x	Port Output configuration bit See Table 2. for configuration definition					

Reset Value = 0000 0000

Table 6. P3M1 Register
P3M1 Address (D5h)

7	6	5	4	3	2	1	0
P3M1.7	P3M1.6	P3M1.5	P3M1.4	P3M1.3	P3M1.2	P3M1.1	P3M1.0
Bit Number	Bit Mnemonic	Description					
0-7	P3M1.x	Port Output configuration bit See Table 2. for configuration definition					

Reset Value = X0X0 X0XX

Table 7. P3M2 Register
P3M2 Address (E4h)

7	6	5	4	3	2	1	0
P3M2.7	P3M2.6	P3M2.5	P3M2.4	P3M2.3	P3M2.2	P3M2.1	P3M2.0
Bit Number	Bit Mnemonic	Description					
0-7	P3M2.x	Port Output configuration bit See Table 2. for configuration definition					

Reset Value = X0X0 X0XX

Dual-data Pointer Register

The additional data pointer can be used to speed up code execution and reduce code size in a number of ways.

The dual DPTR structure is a way by which the device will specify the address of an external data memory location. There are two 16-bit DPTR registers that address the external memory, and a single bit called DPS = AUXR1/bit0 (See Table 8.) that allows the program code to switch between them (Refer to Figure 7).

Figure 7. Use of Dual-data Pointer

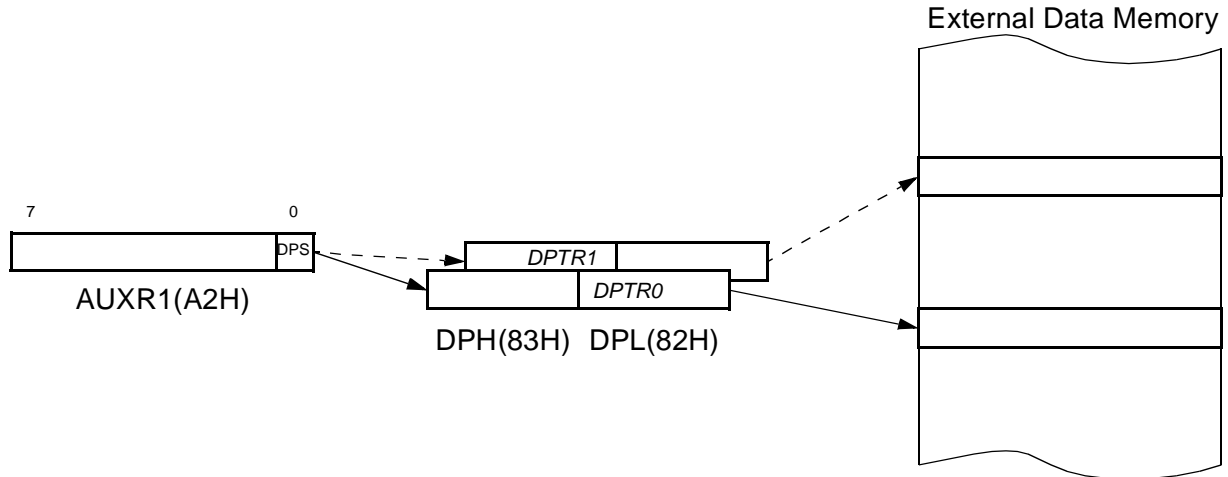

Table 8. AUXR1: Auxiliary Register 1

7	6	5	4	3	2	1	0
-	-	-	-	-	0	-	DPS
Bit Number	Bit Mnemonic	Description					
7	-	Reserved⁽¹⁾ The value read from this bit is indeterminate. Do not set this bit.					
6	-	Reserved The value read from this bit is indeterminate. Do not set this bit.					
5	-	Reserved The value read from this bit is indeterminate. Do not set this bit.					
4	-	Reserved The value read from this bit is indeterminate. Do not set this bit.					
3	-	Reserved The value read from this bit is indeterminate. Do not set this bit.					
2	0	always stuck at 0					
1	-	Reserved The value read from this bit is indeterminate. Do not set this bit.					
0	DPS	Data Pointer Selection Clear to select DPTR0. Set to select DPTR1.					

Note: 1. User software should not write 1s to reserved bits. These bits may be used in future 8051 family products to invoke new feature. In that case, the reset value of the new bit will be 0, and its active value will be 1. The value read from a reserved bit is indeterminate.

Application

Software can take advantage of the additional data pointers to both increase speed and reduce code size, for example, block operations (copy, compare, search...) are well served by using one data pointer as a 'source' pointer and the other one as a "destination" pointer.

ASSEMBLY LANGUAGE

```

; Block move using dual data pointers
; Destroys DPTR0, DPTR1, A and PSW
; note: DPS exits opposite of entry state
; unless an extra INC AUXR1 is added
;
00A2  AUXR1 EQU 0A2H
;
0000 909000MOV DPTR,#SOURCE ; address of SOURCE
0003 05A2 INC AUXR1 ; switch data pointers
0005 90A000 MOV DPTR,#DEST ; address of DEST
0008  LOOP:
0008 05A2 INC AUXR1 ; switch data pointers
000A E0 MOVX A,@DPTR ; get a byte from SOURCE
000B A3 INC DPTR ; increment SOURCE address
000C 05A2 INC AUXR1 ; switch data pointers
000E F0 MOVX @DPTR,A ; write the byte to DEST
000F A3 INC DPTR ; increment DEST address
0010 70F6JNZ LOOP ; check for 0 terminator
0012 05A2 INC AUXR1 ; (optional) restore DPS

```

INC is a short (2 bytes) and fast (12 clocks) way to manipulate the DPS bit in the AUXR1 SFR. However, note that the INC instruction does not directly force the DPS bit to a particular state, but simply toggles it. In simple routines, such as the block move example, only the fact that DPS is toggled in the proper sequence matters, not its actual value. In other words, the block move routine works the same whether DPS is "0" or "1" on entry. Observe that without the last instruction (INC AUXR1), the routine will exit with DPS in the opposite state.

Serial Port Interface (SPI)

The Serial Peripheral Interface module (SPI) which allows full-duplex, synchronous, serial communication between the MCU and peripheral devices, including other MCUs.

Features

Features of the SPI module include the following:

- Full-duplex, three-wire synchronous transfers
- Master or Slave operation
- Eight programmable Master clock rates
- Serial clock with programmable polarity and phase
- Master Mode fault error flag with MCU interrupt capability
- Write collision flag protection

Signal Description

Figure 8 shows a typical SPI Bus configuration using one Master controller and many Slave peripherals. The bus is made of three wires connecting all the devices.

Figure 8. Typical SPI Bus

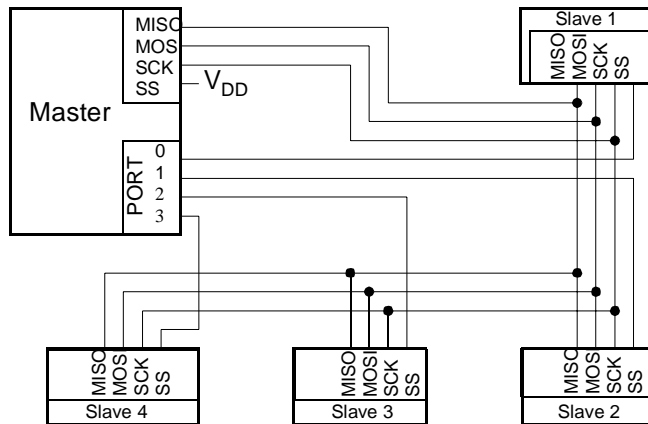

The Master device selects the individual Slave devices by using four pins of a parallel port to control the four \overline{SS} pins of the Slave devices.

Master Output Slave Input (MOSI)

This 1-bit signal is directly connected between the Master device and a Slave device. The MOSI line is used to transfer data in series from the Master to the Slave. Therefore, it is an output signal from the Master, and an input signal to a Slave. A byte (8-bit word) is transmitted most significant bit (MSB) first, least significant bit (LSB) last.

Master Input Slave Output (MISO)

This 1-bit signal is directly connected between the Slave device and a Master device. The MISO line is used to transfer data in series from the Slave to the Master. Therefore, it is an output signal from the Slave, and an input signal to the Master. A byte (8-bit word) is transmitted most significant bit (MSB) first, least significant bit (LSB) last.

SPI Serial Clock (SCK)

This signal is used to synchronize the data movement both in and out the devices through their MOSI and MISO lines. It is driven by the Master for eight clock cycles which allows to exchange one byte on the serial lines.

Slave Select (\overline{SS})

Each Slave peripheral is selected by one Slave Select pin (\overline{SS}). This signal must stay low for any message for a Slave. It is obvious that only one Master (\overline{SS} high level) can drive the network. The Master may select each Slave device by software through port pins (Figure 8). To prevent bus conflicts on the MISO line, only one slave should be selected at a time by the Master for a transmission.

In a Master configuration, the \overline{SS} line can be used in conjunction with the MODF flag in the SPI Status register (SPSTA) to prevent multiple masters from driving MOSI and SCK (See Error Conditions).

A high level on the \overline{SS} pin puts the MISO line of a Slave SPI in a high-impedance state.

The \overline{SS} pin could be used as a general purpose if the following conditions are met:

- The device is configured as a Master and the SSDIS control bit in SPCON is set. This kind of configuration can be found when only one Master is driving the network and there is no way that the \overline{SS} pin will be pulled low. Therefore, the MODF flag in the SPSTA will never be set ⁽¹⁾.
- The Device is configured as a Slave with CPHA and SSDIS control bits set ⁽²⁾. This kind of configuration can happen when the system comprises one Master and one Slave only. Therefore, the \overline{SS} device should always be selected and there is no reason that the Master uses the \overline{SS} pin to select the communicating Slave device.

Baud Rate

In Master mode, the baud rate can be selected from a baud rate generator which is controlled by three bits in the SPCON register: SPR2, SPR1 and SPR0. The Master clock is chosen from one of six clock rates resulting from the division of the internal clock by 4, 8, 16, 32, 64 or 128.

Table 9 gives the different clock rates selected by SPR2:SPR1:SPR0:

Table 9. SPI Master Baud Rate Selection

SPR2:SPR1:SPR0	Clock Rate	Baud Rate Divisor (BD)
000	Don't Use	No BRG
001	$F_{CLK_PERIPH} / 4$	4
010	$F_{CLK_PERIPH} / 8$	8
011	$F_{CLK_PERIPH} / 16$	16
100	$F_{CLK_PERIPH} / 32$	32
101	$F_{CLK_PERIPH} / 64$	64
110	$F_{CLK_PERIPH} / 128$	128
111	Don't Use	No BRG

1. Clearing SSDIS control bit does not clear MODF.
2. Special care should be taken not to set SSDIS control bit when CPHA = "0" because in this mode, the \overline{SS} is used to start the transmission.

Functional Description

Figure 9 shows a detailed structure of the SPI module.

Figure 9. SPI Module Block Diagram

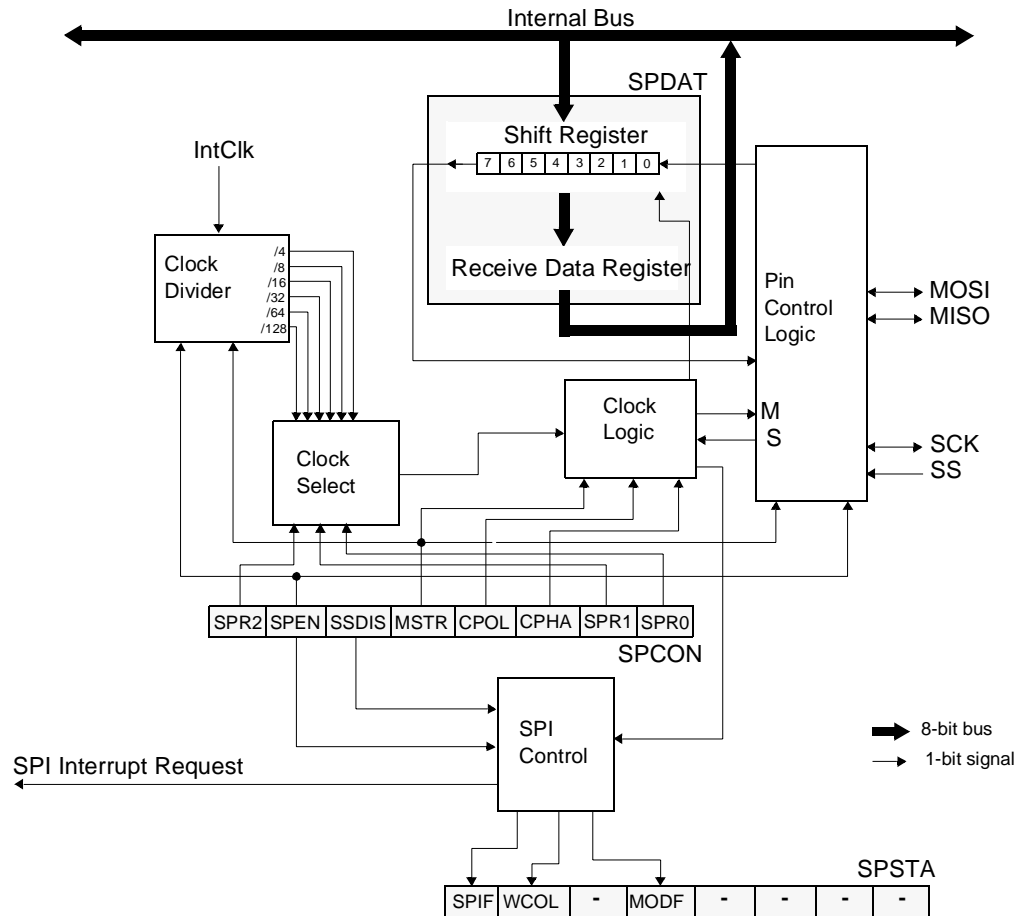

Operating Modes

The Serial Peripheral Interface can be configured as one of the two modes: Master mode or Slave mode. The configuration and initialization of the SPI module is made through one register:

- The Serial Peripheral CONTROL register (SPCON)

Once the SPI is configured, the data exchange is made using:

- SPCON
- The Serial Peripheral STATUS register (SPSTA)
- The Serial Peripheral DATA register (SPDAT)

During an SPI transmission, data is simultaneously transmitted (shifted out serially) and received (shifted in serially). A serial clock line (SCK) synchronizes shifting and sampling on the two serial data lines (MOSI and MISO). A Slave Select line (SS) allows individual selection of a Slave SPI device; Slave devices that are not selected do not interfere with SPI bus activities.

When the Master device transmits data to the Slave device via the MOSI line, the Slave device responds by sending data to the Master device via the MISO line. This implies full-duplex transmission with both data out and data in synchronized with the same clock (Figure 10).

Figure 10. Full-Duplex Master-Slave Interconnection

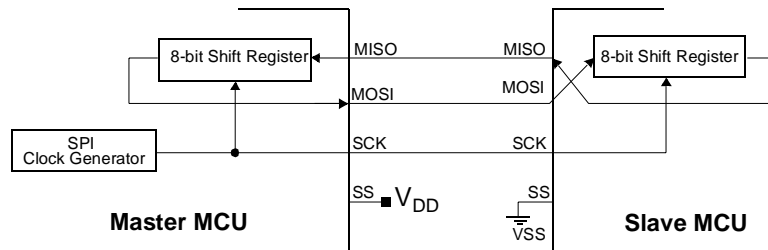

Master Mode

The SPI operates in Master mode when the Master bit, MSTR⁽¹⁾, in the SPCON register is set. Only one Master SPI device can initiate transmissions. Software begins the transmission from a Master SPI module by writing to the Serial Peripheral Data Register (SPDAT). If the shift register is empty, the byte is immediately transferred to the shift register. The byte begins shifting out on MOSI pin under the control of the serial clock, SCK. Simultaneously, another byte shifts in from the Slave on the Master's MISO pin. The transmission ends when the Serial Peripheral transfer data flag, SPIF, in SPSTA becomes set. At the same time that SPIF becomes set, the received byte from the Slave is transferred to the receive data register in SPDAT. Software clears SPIF by reading the Serial Peripheral Status register (SPSTA) with the SPIF bit set, and then reading the SPDAT.

When the pin SS is pulled down during a transmission, the data is interrupted and when the transmission is established again, the data present in the SPDAT is resent.

Slave Mode

The SPI operates in Slave mode when the Master bit, MSTR⁽²⁾, in the SPCON register is cleared. Before a data transmission occurs, the Slave Select pin, SS, of the Slave device must be set to "0". SS must remain low until the transmission is complete.

In a Slave SPI module, data enters the shift register under the control of the SCK from the Master SPI module. After a byte enters the shift register, it is immediately transferred to the receive data register in SPDAT, and the SPIF bit is set. To prevent an overflow condition, Slave software must then read the SPDAT before another byte enters the shift register⁽³⁾. A Slave SPI must complete the write to the SPDAT (shift register) at least one bus cycle before the Master SPI starts a transmission. If the write to the data register is late, the SPI transmits the data already in the shift register from the previous transmission.

Transmission Formats

Software can select any of four combinations of serial clock (SCK) phase and polarity using two bits in the SPCON: the Clock POLarity (CPOL⁽⁴⁾) and the Clock PHase (CPHA⁽⁴⁾). CPOL defines the default SCK line level in idle state. It has no significant effect on the transmission format. CPHA defines the edges on which the input data are sampled and the edges on which the output data are shifted (Figure 11 and Figure 12). The clock phase and polarity should be identical for the Master SPI device and the communicating Slave device.

1. The SPI module should be configured as a Master before it is enabled (SPEN set). Also the Master SPI should be configured before the Slave SPI.
2. The SPI module should be configured as a Slave before it is enabled (SPEN set).
3. The maximum frequency of the SCK for an SPI configured as a Slave is the bus clock speed.
4. Before writing to the CPOL and CPHA bits, the SPI should be disabled (SPEN = "0").

Figure 11. Data Transmission Format (CPHA = 0)

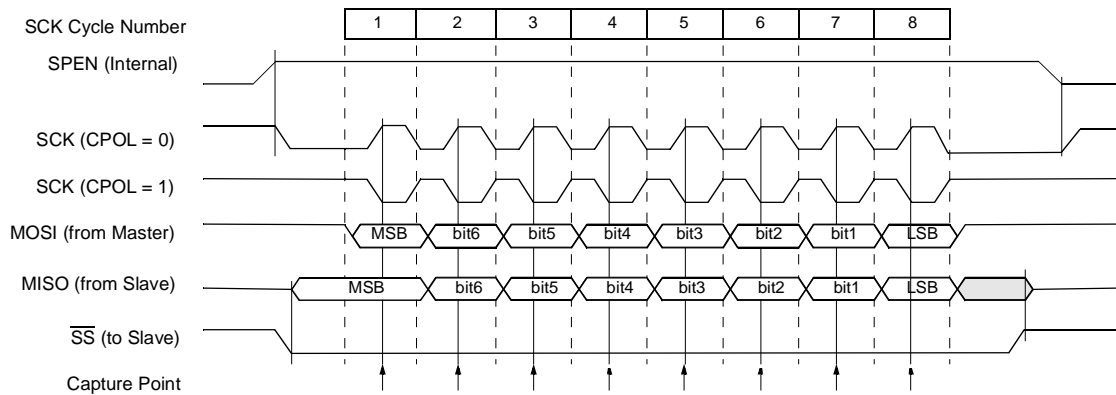
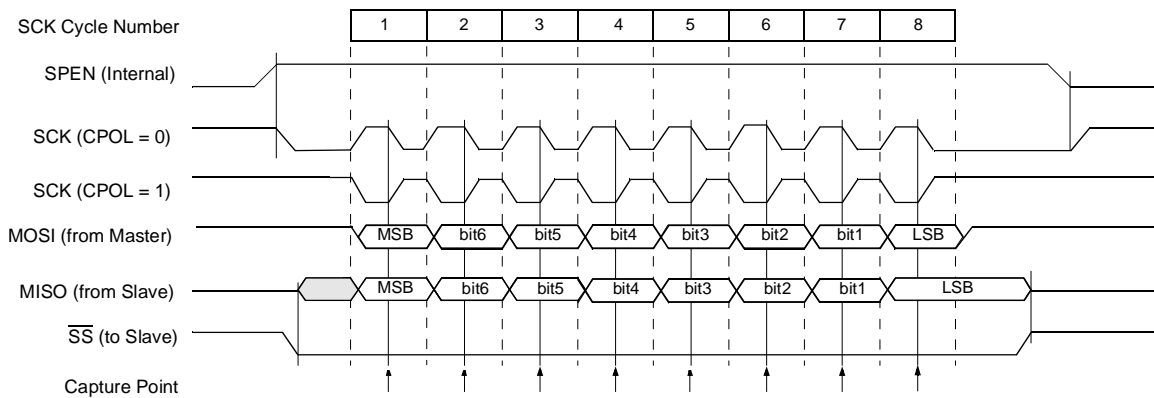

Figure 12. Data Transmission Format (CPHA = 1)



As shown in Figure 11, the first SCK edge is the MSB capture strobe. Therefore, the Slave must begin driving its data before the first SCK edge, and a falling edge on the SS pin is used to start the transmission. The SS pin must be toggled high and then low between each byte transmitted (Figure 13).

Figure 13. CPHA/SS Timing

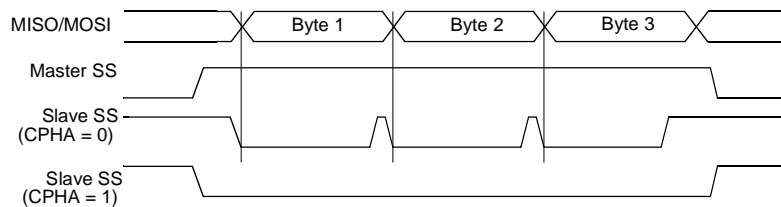

Figure 12 shows an SPI transmission in which CPHA is “1”. In this case, the Master begins driving its MOSI pin on the first SCK edge. Therefore the Slave uses the first SCK edge as a start transmission signal. The SS pin can remain low between transmissions (Figure 13). This format may be preferable in systems having only one Master and only one Slave driving the MISO data line.

Error Conditions

The following flags in the SPSTA signal SPI error conditions.

Mode Fault (MODF)

MODE Fault error in Master mode SPI indicates that the level on the Slave Select (\overline{SS}) pin is inconsistent with the actual mode of the device. MODF is set to warn that there may have a multi-master conflict for system control. In this case, the SPI system is affected in the following ways:

- An SPI receiver/error CPU interrupt request is generated.
- The SPEN bit in SPCON is cleared. This disable the SPI.
- The MSTR bit in SPCON is cleared.

When SS DISable (SSDIS) bit in the SPCON register is cleared, the MODF flag is set when the SS signal becomes "0".

However, as stated before, for a system with one Master, if the \overline{SS} pin of the Master device is pulled low, there is no way that another Master is attempting to drive the network. In this case, to prevent the MODF flag from being set, software can set the SSDIS bit in the SPCON register and therefore making the SS pin as a general-purpose I/O pin.

Clearing the MODF bit is accomplished by a read of SPSTA register with MODF bit set, followed by a write to the SPCON register. SPEN Control bit may be restored to its original set state after the MODF bit has been cleared.

Write Collision (WCOL)

A Write COLLision (WCOL) flag in the SPSTA is set when a write to the SPDAT register is done during a transmit sequence.

WCOL does not cause an interruption, and the transfer continues uninterrupted.

Clearing the WCOL bit is done through a software sequence of an access to SPSTA and an access to SPDAT.

Overrun Condition

An overrun condition occurs when the Master device tries to send several data bytes and the Slave device has not cleared the SPIF bit issuing from the previous data byte transmitted. In this case, the receiver buffer contains the byte sent after the SPIF bit was last cleared. A read of the SPDAT returns this byte. All others bytes are lost.

This condition is not detected by the SPI peripheral.

SS Error Flag (SSERR)

A Synchronous Serial Slave Error occurs when \overline{SS} goes high before the end of a received data in slave mode. SSERR does not cause in interruption, this bit is cleared by writing 0 to SPEN bit (reset of the SPI state machine).

Interrupts

Two SPI status flags can generate a CPU interrupt requests (See Table 10)

Table 10. SPI Interrupts

Flag	Request
SPIF (SP data transfer)	SPI Transmitter Interrupt request
MODF (Mode Fault)	SPI Receiver/Error Interrupt Request (if SSDIS = "0")

Serial Peripheral data transfer flag, SPIF: This bit is set by hardware when a transfer has been completed. SPIF bit generates transmitter CPU interrupt requests.

Mode Fault flag, MODF: This bit becomes set to indicate that the level on the \overline{SS} is inconsistent with the mode of the SPI. MODF with SSDIS reset, generates receiver/error CPU interrupt requests.

Figure 14 gives a logic view of the above statements.

Figure 14. SPI Interrupt Requests Generation

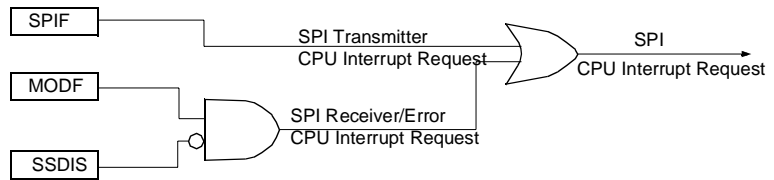

Registers

Serial Peripheral Control Register (SPCON)

There are three registers in the module that provide control, status and data storage functions. These registers are describes in the following paragraphs.

The Serial Peripheral Control Register does the following:

- Selects one of the Master clock rates
- Configure the SPI module as Master or Slave
- Selects serial clock polarity and phase
- Enables the SPI module
- Frees the SS pin for a general purpose

Table 11 describes this register and explains the use of each bit.

Table 11. Serial Peripheral Control Register

	7	6	5	4	3	2	1	0
	SPR2	SPEN	SSDIS	MSTR	CPOL	CPHA	SPR1	SPR0
Bit Number	Bit Mnemonic	R/W Mode	Description					
7	SPR2	R/W	Serial Peripheral Rate 2 Bit with SPR1 and SPR0 define the clock rate					
6	SPEN	R/W	Serial Peripheral Enable Clear to disable the SPI interface (internal reset of the SPI) Set to enable the SPI interface					
5	SSDIS	R/W	\overline{SS} Disable Clear to enable \overline{SS} in both Master and Slave modes Set to disable \overline{SS} in both Master and Slave modes. In Slave mode, this bit has no effect if CPHA = "0"					
4	MSTR	R/W	Serial Peripheral Master Clear to configure the SPI as a Slave Set to configure the SPI as a Master					
3	CPOL	R/W	Clock Polarity Clear to have the SCK set to '0' in idle state Set to have the SCK set to '1' in idle low					
2	CPHA	R/W	Clock Phase Clear to have the data sampled when the SPSCCK leaves the idle state (see CPOL) Set to have the data sampled when the SPSCCK returns to idle state (see CPOL)					

Bit Number	Bit Mnemonic	R/W Mode	Description
1	SPR1	R/W	Serial Peripheral Rate (SPR2:SPR1:SPR0) 000: N.A. 001: $F_{CLK PERIPH} / 4$ 010: $F_{CLK PERIPH} / 8$ 011: $F_{CLK PERIPH} / 16$
0	SPR0	R/W	100: $F_{CLK PERIPH} / 32$ 101: $F_{CLK PERIPH} / 64$ 110: $F_{CLK PERIPH} / 128$ 111: Don't Use

Reset Value = 00010100b

Serial Peripheral Status Register (SPSTA)

The Serial Peripheral Status Register contains flags to signal the following conditions:

- Data transfer complete
- Write collision
- Inconsistent logic level on SS pin (mode fault error)

Table 12 describes the SPSTA register and explains the use of every bit in the register.

Table 12. Serial Peripheral Status and Control Register

7	6	5	4	3	2	1	0
SPIF	WCOL	SSERR	MODF	-	-	-	-
Bit Number	Bit Mnemonic	R/W Mode	Description				
7	SPIF	R	Serial Peripheral Data Transfer Flag Clear by hardware to indicate data transfer is in progress or has been approved by a clearing sequence. Set by hardware to indicate that the data transfer has been completed.				
6	WCOL	R	Write Collision Flag Cleared by hardware to indicate that no collision has occurred or has been approved by a clearing sequence. Set by hardware to indicate that a collision has been detected.				
5	SSERR	R	Synchronous Serial Slave Error Flag Set by hardware when \overline{SS} is deasserted before the end of a received data. Cleared by disabling the SPI (clearing SPEN bit in SPCON).				
4	MODF	R	Mode Fault Cleared by hardware to indicate that the SS pin is at appropriate logic level, or has been approved by a clearing sequence. Set by hardware to indicate that the SS pin is at inappropriate logic level				
3	-	R/W	Reserved The value read from this bit is indeterminate. Do not set this bit.				

Bit Number	Bit Mnemonic	R/W Mode	Description
2	-	R/W	Reserved The value read from this bit is indeterminate. Do not set this bit.
1	-	R/W	Reserved The value read from this bit is indeterminate. Do not set this bit.
0	-	R/W	Reserved The value read from this bit is indeterminate. Do not set this bit.

Reset Value = 00X0XXXXb

Serial Peripheral Data Register (SPDAT)

The Serial Peripheral Data Register (Table 13) is a read/write buffer for the receive data register. A write to SPDAT places data directly into the shift register. No transmit buffer is available in this mode.

A Read of the SPDAT returns the value located in the receive buffer and not the content of the shift register.

Table 13. Serial Peripheral Data Register

7	6	5	4	3	2	1	0
R7	R6	R5	R4	R3	R2	R1	R0

Reset Value = XXXX XXXXb

R7:R0: Receive data bits

SPCON, SPSTA and SPDAT registers may be read and written at any time while there is no on-going exchange. However, special care should be taken when writing to them while a transmission is on-going:

- Do not change SPR2, SPR1 and SPR0
- Do not change CPHA and CPOL
- Do not change MSTR
- Clearing SPEN would immediately disable the peripheral
- Writing to the SPDAT will cause an overflow

Timers/Counters

The AT8xC5103 implements two general-purpose, 16-bit Timers/Counters. They are identified as Timer 0 and Timer 1, and can be independently configured to operate in a variety of modes as a Timer or as an event Counter. When operating as a Timer, the Timer/Counter runs for a programmed length of time, then issues an interrupt request. When operating as a Counter, the Timer/Counter counts negative transitions on an external pin. After a preset number of counts, the Counter issues an interrupt request. The various operating modes of each Timer/Counter are described in the following sections.

Timer/Counter Operations

For instance, a basic operation is Timer registers THx and TLx ($x = 0, 1$) connected in cascade to form a 16-bit Timer. Setting the run control bit (TRx) in TCON register (see Figure 14) turns the Timer on by allowing the selected input to increment TLx. When TLx overflows it increments THx; when THx overflows it sets the Timer overflow flag (TFx) in TCON register. Setting the TRx does not clear the THx and TLx Timer registers. Timer registers can be accessed to obtain the current count or to enter preset values. They can be read at any time but TRx bit must be cleared to preset their values, other/wise the behavior of the Timer/Counter is unpredictable.

The C/Tx# control bit selects Timer operation or Counter operation by selecting the divided-down peripheral clock or external pin Tx as the source for the counted signal. TRx bit must be cleared when changing the mode of operation, other/wise the behavior of the Timer/Counter is unpredictable.

For Timer operation ($C/Tx\# = 0$), the Timer register counts the divided-down peripheral clock. The Timer register is incremented once every peripheral cycle (6 peripheral clock periods). The Timer clock rate is $F_{PER}/6$, i.e. $F_{OSC}/12$ in standard mode or $F_{OSC}/6$ in X2 Mode.

For Counter operation ($C/Tx\# = 1$), the Timer register counts the negative transitions on the Tx external input pin. The external input is sampled every peripheral cycles. When the sample is high in one cycle and low in the next one, the Counter is incremented. Since it takes 2 cycles (12 peripheral clock periods) to recognize a negative transition, the maximum count rate is $F_{PER}/12$, i.e. $F_{OSC}/24$ in standard mode or $F_{OSC}/12$ in X2 Mode. There are no restrictions on the duty cycle of the external input signal, but to ensure that a given level is sampled at least once before it changes, it should be held for at least one full peripheral cycle.

Timer 0

Timer 0 functions as either a Timer or event Counter in four modes of operation. Figure 15 through Figure 18 show the logical configuration of each mode.

Timer 0 is controlled by the four lower bits of TMOD register (See Figure 15) and bits 0, 1, 4 and 5 of TCON register (see Figure 14). TMOD register selects the method of Timer gating (GATE0), Timer or Counter operation (T/C0#) and mode of operation (M10 and M00). TCON register provides Timer 0 control functions: overflow flag (TF0), run control bit (TR0), interrupt flag (IE0) and interrupt type control bit (IT0).

For normal Timer operation ($GATE0 = 0$), setting TR0 allows TL0 to be incremented by the selected input. Setting GATE0 and TR0 allows external pin INT0# to control Timer operation.

Timer 0 overflow (count rolls over from all 1s to all 0s) sets TF0 flag generating an interrupt request.

It is important to stop Timer/Counter before changing mode.

Mode 0 (13-bit Timer)

Mode 0 configures Timer 0 as a 13-bit Timer which is set up as an 8-bit Timer (TH0 register) with a modulo 32 prescaler implemented with the lower five bits of TL0 register (see Figure 15). The upper three bits of TL0 register are indeterminate and should be ignored. Prescaler overflow increments TH0 register.

Figure 15. Timer/Counter x (x = 0 or 1) in Mode 0

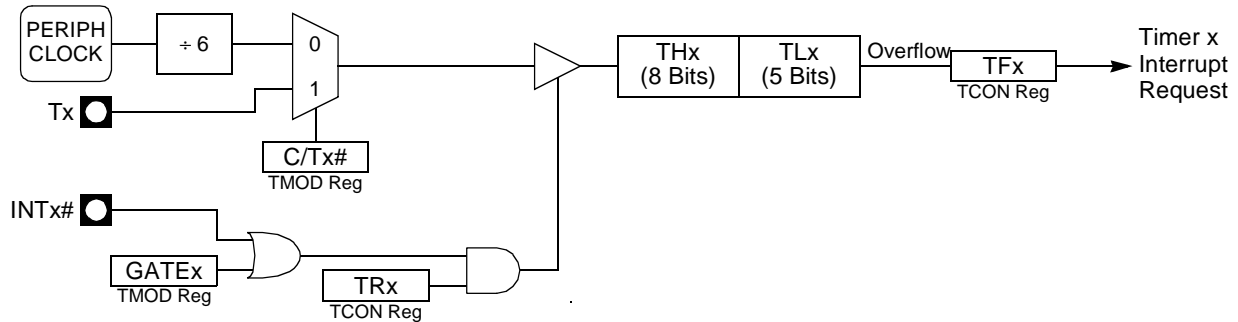

Mode 1 (16-bit Timer)

Mode 1 configures Timer 0 as a 16-bit Timer with TH0 and TL0 registers connected in cascade (see Figure 16). The selected input increments TL0 register.

Figure 16. Timer/Counter x (x = 0 or 1) in Mode 1

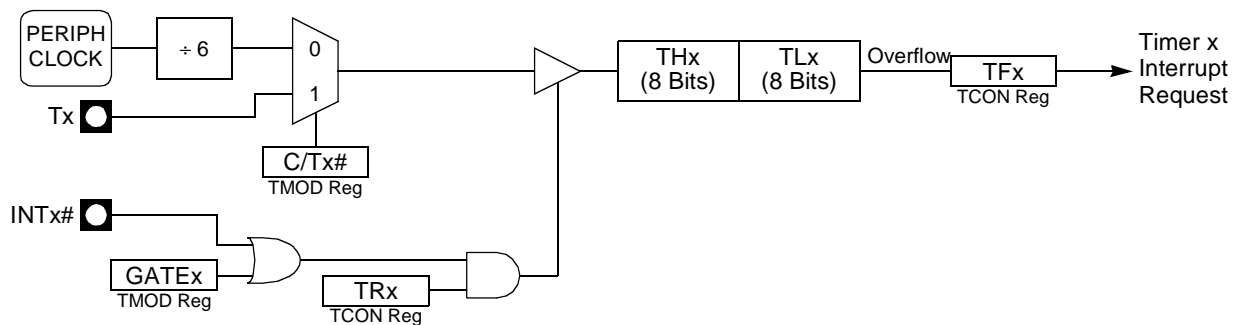

Mode 2 (8-bit Timer with Auto-Reload)

Mode 2 configures Timer 0 as an 8-bit Timer (TL0 register) that automatically reloads from TH0 register (see Figure 17). TL0 overflow sets TF0 flag in TCON register and reloads TL0 with the contents of TH0, which is preset by software. When the interrupt request is serviced, hardware clears TF0. The reload leaves TH0 unchanged. The next reload value may be changed at any time by writing to TH0 register.

Figure 17. Timer/Counter x (x = 0 or 1) in Mode 2

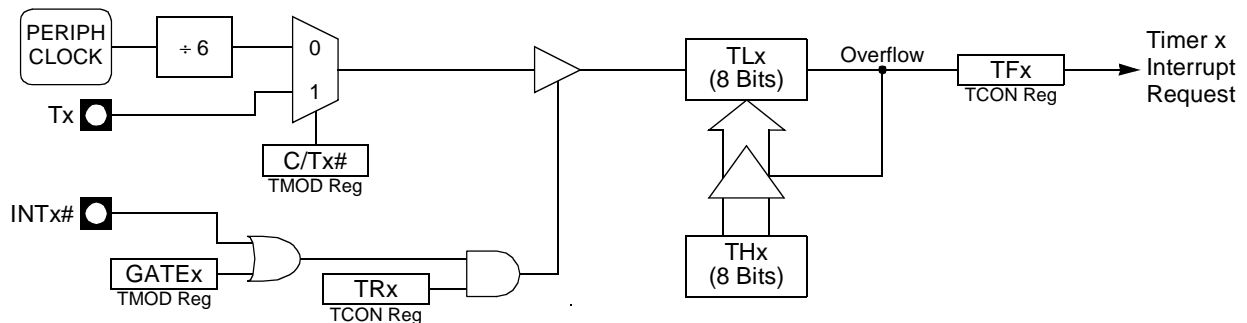

Mode 3 (Two 8-bit Timers)

Mode 3 configures Timer 0 such that registers TL0 and TH0 operate as separate 8-bit Timers (see Figure 18). This mode is provided for applications requiring an additional 8-bit Timer or Counter. TL0 uses the Timer 0 control bits C/T0# and GATE0 in TMOD register, and TR0 and TF0 in TCON register in the normal manner. TH0 is locked into a Timer function (counting $F_{PER} / 6$) and takes over use of the Timer 1 interrupt (TF1) and run control (TR1) bits. Thus, operation of Timer 1 is restricted when Timer 0 is in Mode 3.

Figure 18. Timer/Counter 0 in Mode 3: Two 8-bit Counters

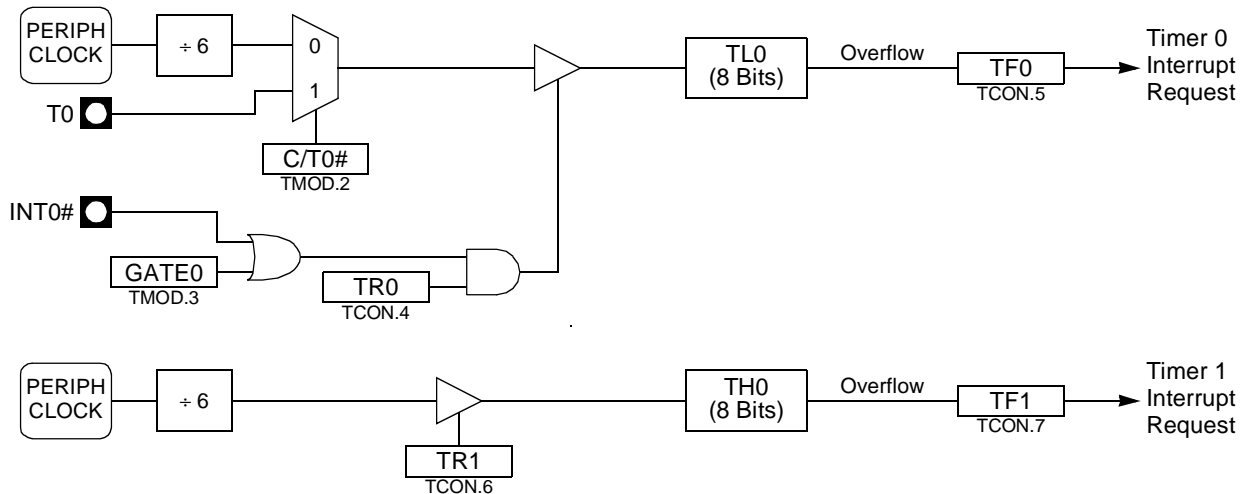

Timer 1

Timer 1 is identical to Timer 0 excepted for Mode 3 which is a hold-count mode. The following comments help to understand the differences:

- Timer 1 functions as either a Timer or event Counter in three modes of operation. Figure 15 through Figure 17 show the logical configuration for modes 0, 1, and 2. Timer 1's Mode 3 is a hold-count mode.
- Timer 1 is controlled by the four high-order bits of TMOD register (see Figure 15) and bits 2, 3, 6 and 7 of TCON register (see Figure 14). TMOD register selects the method of Timer gating (GATE1), Timer or Counter operation (C/T1#) and mode of operation (M11 and M01). TCON register provides Timer 1 control functions: overflow flag (TF1), run control bit (TR1), interrupt flag (IE1) and interrupt type control bit (IT1).
- Timer 1 can serve as the Baud Rate Generator for the Serial Port. Mode 2 is best suited for this purpose.
- For normal Timer operation (GATE1 = 0), setting TR1 allows TL1 to be incremented by the selected input. Setting GATE1 and TR1 allows external pin INT1# to control Timer operation.
- Timer 1 overflow (count rolls over from all 1s to all 0s) sets the TF1 flag generating an interrupt request.
- When Timer 0 is in Mode 3, it uses Timer 1's overflow flag (TF1) and run control bit (TR1). For this situation, use Timer 1 only for applications that do not require an interrupt (such as a Baud Rate Generator for the Serial Port) and switch Timer 1 in and out of Mode 3 to turn it off and on.
- It is important to stop Timer/Counter before changing mode.

Mode 0 (13-bit Timer)

Mode 0 configures Timer 1 as a 13-bit Timer, which is set up as an 8-bit Timer (TH1 register) with a modulo-32 prescaler implemented with the lower 5 bits of the TL1 register (see Figure 15). The upper 3 bits of TL1 register are ignored. Prescaler overflow increments TH1 register.

Mode 1 (16-bit Timer)

Mode 1 configures Timer 1 as a 16-bit Timer with TH1 and TL1 registers connected in cascade (see Figure 16). The selected input increments TL1 register.

Mode 2 (8-bit Timer with Auto-Reload)

Mode 2 configures Timer 1 as an 8-bit Timer (TL1 register) with automatic reload from TH1 register on overflow (see Figure 17). TL1 overflow sets TF1 flag in TCON register and reloads TL1 with the contents of TH1, which is preset by software. The reload leaves TH1 unchanged.

Mode 3 (Halt)

Placing Timer 1 in Mode 3 causes it to halt and hold its count. This can be used to halt Timer 1 when TR1 run control bit is not available i.e. when Timer 0 is in Mode 3.

Interrupt

Each Timer handles one interrupt source that is the timer overflow flag TF0 or TF1. This flag is set every time an overflow occurs. Flags are cleared when vectoring to the Timer interrupt routine. Interrupts are enabled by setting ETx bit in IE0 register. This assumes interrupts are globally enabled by setting EA bit in IE0 register.

Figure 19. Timer Interrupt System

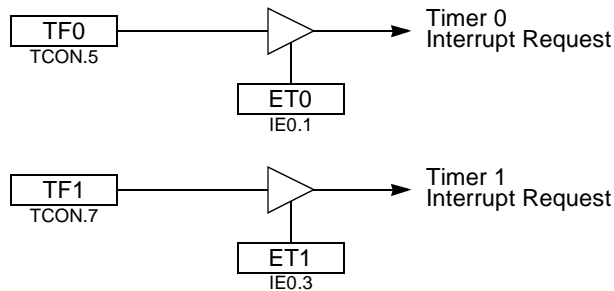

Registers

Table 14. TCON Register
 TCON (S:88h)
 Timer/Counter Control Register

7	6	5	4	3	2	1	0
TF1	TR1	TF0	TR0	IE1	IT1	IE0	IT0
Bit Number	Bit Mnemonic	Description					
7	TF1	Timer 1 Overflow Flag Cleared by hardware when processor vectors to interrupt routine. Set by hardware on Timer/Counter overflow, when Timer 1 register overflows.					
6	TR1	Timer 1 Run Control Bit Clear to turn off Timer/Counter 1. Set to turn on Timer/Counter 1.					
5	TF0	Timer 0 Overflow Flag Cleared by hardware when processor vectors to interrupt routine. Set by hardware on Timer/Counter overflow, when Timer 0 register overflows.					
4	TR0	Timer 0 Run Control Bit Clear to turn off Timer/Counter 0. Set to turn on Timer/Counter 0.					
3	IE1	Interrupt 1 Edge Flag Cleared by hardware when interrupt is processed if edge-triggered (see IT1). Set by hardware when external interrupt is detected on INT1# pin.					
2	IT1	Interrupt 1 Type Control Bit Clear to select low level active (level triggered) for external interrupt 1 (INT1#). Set to select falling edge active (edge triggered) for external interrupt 1.					
1	IE0	Interrupt 0 Edge Flag Cleared by hardware when interrupt is processed if edge-triggered (see IT0). Set by hardware when external interrupt is detected on INT0# pin.					
0	IT0	Interrupt 0 Type Control Bit Clear to select low level active (level triggered) for external interrupt 0 (INT0#). Set to select falling edge active (edge triggered) for external interrupt 0.					

Reset Value = 0000 0000b

Table 15. TMOD Register
 TMOD (S:89h)
 Timer/Counter Mode Control Register

	7	6	5	4	3	2	1	0
	GATE1	C/T1#	M11	M01	GATE0	C/T0#	M10	M00

Bit Number	Bit Mnemonic	Description
7	GATE1	Timer 1 Gating Control Bit Clear to enable Timer 1 whenever TR1 bit is set. Set to enable Timer 1 only while INT1# pin is high and TR1 bit is set.
6	C/T1#	Timer 1 Counter/Timer Select Bit Clear for Timer operation: Timer 1 counts the divided-down system clock. Set for Counter operation: Timer 1 counts negative transitions on external pin T1.
5	M11	Timer 1 Mode Select Bits <u>M11 M01 Operating mode</u> 0 0 Mode 0: 8-bit Timer/Counter (TH1) with 5-bit prescaler (TL1). 0 1 Mode 1: 16-bit Timer/Counter. 1 0 Mode 2: 8-bit auto-reload Timer/Counter (TL1). Reloaded from TH1 at overflow. 1 1 Mode 3: Timer 1 halted. Retains count.
4	M01	
3	GATE0	Timer 0 Gating Control Bit Clear to enable Timer 0 whenever TR0 bit is set. Set to enable Timer/Counter 0 only while INT0# pin is high and TR0 bit is set.
2	C/T0#	Timer 0 Counter/Timer Select Bit Clear for Timer operation: Timer 0 counts the divided-down system clock. Set for Counter operation: Timer 0 counts negative transitions on external pin T0.
1	M10	Timer 0 Mode Select Bit <u>M10 M00 Operating mode</u> 0 0 Mode 0: 8-bit Timer/Counter (TH0) with 5-bit prescaler (TL0). 0 1 Mode 1: 16-bit Timer/Counter. 1 0 Mode 2: 8-bit auto-reload Timer/Counter (TL0). Reloaded from TH0 at overflow. 1 1 Mode 3: TL0 is an 8-bit Timer/Counter. TH0 is an 8-bit Timer using Timer 1's TR0 and TF0 bits.
0	M00	

Reset Value = 0000 0000b

Table 16. TH0 Register
 TH0 (S:8Ch)
 Timer 0 High Byte Register

	7	6	5	4	3	2	1	0

Bit Number	Bit Mnemonic	Description
7:0		High Byte of Timer 0

Reset Value = 0000 0000b

Table 17. TL0 Register
 TL0 (S:8Ah)
 Timer 0 Low Byte Register

7	6	5	4	3	2	1	0
Bit Number	Bit Mnemonic	Description					
7:0		Low Byte of Timer 0					

Reset Value = 0000 0000b

Table 18. TH1 Register
 TH1 (S:8Dh)
 Timer 1 High Byte Register

7	6	5	4	3	2	1	0
Bit Number	Bit Mnemonic	Description					
7:0		High Byte of Timer 1					

Reset Value = 0000 0000b

Table 19. TL1 Register
 TL1 (S:8Bh)
 Timer 1 Low Byte Register

7	6	5	4	3	2	1	0
Bit Number	Bit Mnemonic	Description					
7:0		Low Byte of Timer 1					

Reset Value = 0000 0000b

Power Management

Table 20. PCON Register
PCON - Power Control Register (87h)

7	6	5	4	3	2	1	0
-	-	-	-	GF1	GF0	PD	IDL
Bit Number	Bit Mnemonic	Description					
7	-	Reserved The value read from this bit is indeterminate. Do not set this bit.					
6	-	Reserved The value read from this bit is indeterminate. Do not set this bit.					
5	-	Reserved The value read from this bit is indeterminate. Do not set this bit.					
4	-	Reserved The value read from this bit is indeterminate. Do not set this bit.					
3	GF1	General-purpose Flag Cleared by user for general purpose usage. Set by user for general purpose usage.					
2	GF0	General-purpose Flag Cleared by user for general purpose usage. Set by user for general purpose usage.					
1	PD	Power-Down Mode Bit Cleared by hardware when reset occurs. Set to enter power-down mode.					
0	IDL	Idle Mode Bit Cleared by hardware when interrupt or reset occurs. Set to enter idle mode.					

Reset Value = 00X1 0000b

Not bit addressable

Idle Mode

An instruction that sets PCON.0 indicates that it is the last instruction to be executed before going into the Idle mode. In the Idle mode, the internal clock signal is gated off to the CPU, but not to the interrupt, Timer, and Serial Port functions. The CPU status is preserved in its entirety: the Stack Pointer, Program Counter, Program Status Word, Accumulator and all other registers maintain their data during Idle. The port pins hold the logical states they had at the time Idle was activated.

There are two ways to terminate the Idle mode. Activation of any enabled interrupt will cause PCON.0 to be cleared by hardware, terminating the Idle mode. The interrupt will be serviced, and following RETI the next instruction to be executed will be the one following the instruction that put the device into idle.

The flag bits GF0 and GF1 can be used to give an indication if an interrupt occurred during normal operation or during an Idle. For example, an instruction that activates Idle can also set one or both flag bits. When Idle is terminated by an interrupt, the interrupt service routine can examine the flag bits.

The other way of terminating the Idle mode is with a hardware reset. Since the clock oscillator is still running, the hardware reset needs to be held active for only two machine cycles (24 oscillator periods) to complete the reset.

Power-down Mode

To save maximum power, a power-down mode can be invoked by software (refer to Table 13, PCON register).

In power-down mode, the oscillator is stopped and the instruction that invoked power-down mode is the last instruction executed. The internal RAM and SFRs retain their value until the power-down mode is terminated. V_{CC} can be lowered to save further power. Either a hardware reset or an external interrupt can cause an exit from power-down. To properly terminate power-down mode, the reset or external interrupt should not be executed before V_{CC} is restored to its normal operating level and must be held active long enough for the oscillator to restart and stabilize.

Only external interrupts $\overline{INT0}$, $\overline{INT1}$ are useful for exiting from power-down. For that, interrupt must be enabled and configured as level or edge sensitive interrupt input.

Holding the pin low restarts the oscillator but bringing the pin high completes the exit as detailed in Figure 20. When both interrupts are enabled, the oscillator restarts as soon as one of the two inputs is held low and power-down exit will be completed when the first input is released. In this case the higher priority interrupt service routine is executed. Once the interrupt is serviced, the next instruction to be executed after RETI will be the one following the instruction that put AT8xC5103 into power-down mode.

Figure 20. Power-Down Exit Waveform

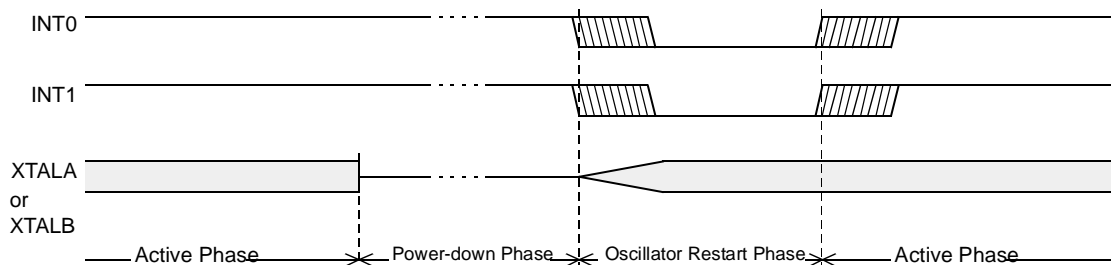

Exiting from power-down by reset redefines all the SFRs, exiting from power-down by external interrupt does not affect the SFRs.

Exiting from power-down by either reset or external interrupt does not affect the internal RAM content.

Note: If idle mode is activated with power-down mode (IDL and PD bits set), the exit sequence is unchanged, when execution is vectored to interrupt, PD and IDL bits are cleared and idle mode is not entered.

Table 21 shows the state of ports during idle and power-down modes.

Table 21. State of Ports⁽¹⁾

Mode	Program Memory	PORT1	PORT3
Idle	Internal	Port Data	Port Data
Power-down	Internal	Port Data	Port Data

Note: 1. Port 0 can force a 0 level. A 'one' will leave port floating.

Programmable Counter Array (PCA)

The PCA provides more timing capabilities with less CPU intervention than the standard timer/counters. Its advantages include reduced software overhead and improved accuracy. The PCA consists of a dedicated timer/counter which serves as the time base for an array of five compare/capture modules. Its clock input can be programmed to count any one of the following signals:

- Oscillator frequency $\div 12$ ($\div 6$ in X2 Mode)
- Oscillator frequency $\div 4$ ($\div 2$ in X2 Mode)
- Timer 0 overflow
- External input on ECI (P1.2)

Each compare/capture modules can be programmed in any one of the following modes:

- Rising and/or falling edge capture,
- Software timer
- High-speed output
- Pulse width modulator.

Module 4 can also be programmed as a watchdog timer.

When the compare/capture modules are programmed in the capture mode, software timer, or high speed output mode, an interrupt can be generated when the module executes its function. All five modules and the PCA timer overflow share one interrupt vector.

The PCA timer/counter and compare/capture modules share Port 1 for external I/O. These pins are listed below. If the port is not used for the PCA, it can still be used for standard I/O.

PCA Component	External I/O Pin
16-bit Counter	P1.2/ECI
16-bit Module 0	P1.3/CEX0
16-bit Module 1	P1.4/CEX1
16-bit Module 2	P1.5/CEX2
16-bit Module 3	P1.6/CEX3
16-bit Module 4	P1.7/CEX4

The PCA timer is a common time base for all five modules (See Figure 21). The timer count source is determined from the CPS1 and CPS0 bits in the CMOD SFR (see Table 22) and can be programmed to run at:

- 1/12 the oscillator frequency (or 1/6 in X2 Mode)
- 1/4 the oscillator frequency (or 1/2 in X2 Mode)
- The Timer 0 overflow
- The input on the ECI pin (P1.2)

PCA Timer

Figure 21. PCA Timer/Counter

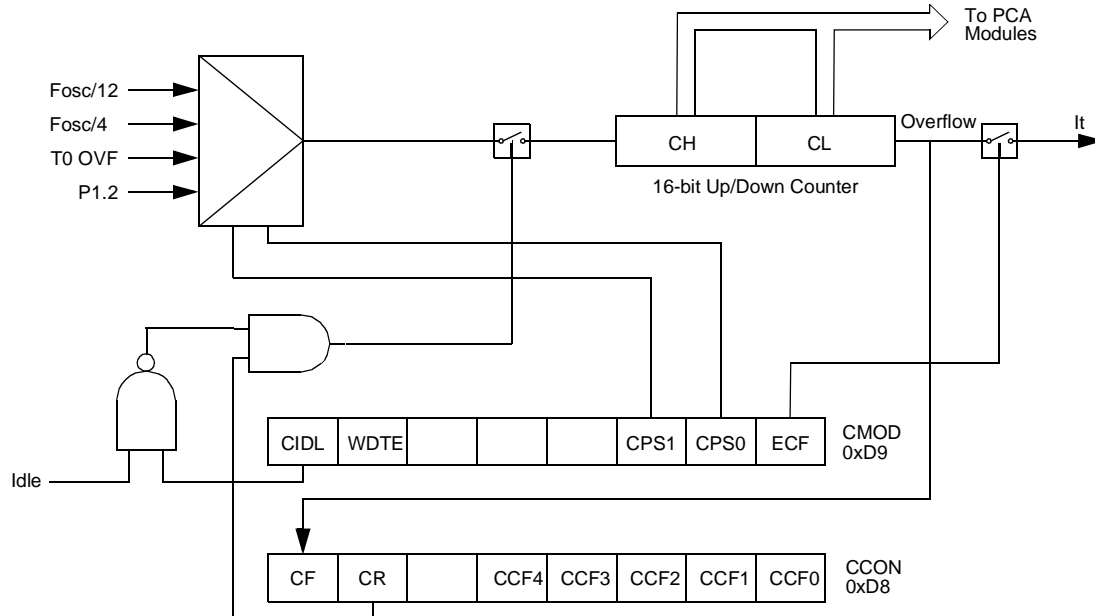

Table 22. CMOD: PCA Counter Mode Register

CMOD Address 0D9H	CIDL	WDTE	-	-	-	CPS1	CPS0	ECF
Reset value	0	0	X	X	X	0	0	0

Symbol	Function	
CIDL	Counter Idle control: CIDL = 0 programs the PCA Counter to continue functioning during idle Mode. CIDL = 1 programs it to be gated off during idle.	
WDTE	Watchdog Timer Enable: WDTE = 0 disables Watchdog Timer function on PCA Module 4. WDTE = 1 enables it.	
-	Not implemented, reserved for future use. ⁽¹⁾	
CPS1	PCA Count Pulse Select bit 1.	
CPS0	PCA Count Pulse Select bit 0.	
	CPS1 CPS0	Selected PCA input. ⁽²⁾
	0 0	Internal clock $f_{osc}/12$ (Or $f_{osc}/6$ in X2 Mode).
	0 1	Internal clock $f_{osc}/4$ (Or $f_{osc}/2$ in X2 Mode).
	1 0	Timer 0 Overflow
1 1	External clock at ECI/P1.2 pin (max rate = $f_{osc}/8$)	
ECF	PCA Enable Counter Overflow interrupt: ECF = 1 enables CF bit in CCON to generate an interrupt. ECF = 0 disables that function of CF.	

1. User software should not write 1s to reserved bits. These bits may be used in future 8051 family products to invoke new features. In that case, the reset or inactive value of the new bit will be 0, and its active value will be 1. The value read from a reserved bit is indeterminate.
2. f_{osc} = oscillator frequency

The CMOD SFR includes three additional bits associated with the PCA (See Figure 21 and Table 22).

- The CIDL bit which allows the PCA to stop during idle mode.
- The WDTE bit which enables or disables the watchdog function on module 4.
- The ECF bit which when set causes an interrupt and the PCA overflow flag CF (in the CCON SFR) to be set when the PCA timer overflows.

The CCON SFR contains the run control bit for the PCA and the flags for the PCA timer (CF) and each module (Refer to Table 23).

- Bit CR (CCON.6) must be set by software to run the PCA. The PCA is shut off by clearing this bit.
- Bit CF: The CF bit (CCON.7) is set when the PCA counter overflows and an interrupt will be generated if the ECF bit in the CMOD register is set. The CF bit can only be cleared by software.
- Bits 0 through 4 are the flags for the modules (bit 0 for module 0, bit 1 for module 1, etc.) and are set by hardware when either a match or a capture occurs. These flags also can only be cleared by software.

Table 23. CCON: PCA Counter Control Register

CCON Address 0D8H		CF	CR	-	CCF4	CCF3	CCF2	CCF1	CCF0
Reset Value		0	0	X	0	0	0	0	0

Symbol	Function
CF	PCA Counter Overflow flag. Set by hardware when the counter rolls over. CF flags an interrupt if bit ECF in CMOD is set. CF may be set by either hardware or software but can only be cleared by software.
CR	PCA Counter Run control bit. Set by software to turn the PCA counter on. Must be cleared by software to turn the PCA counter off.
-	Not implemented, reserved for future use. ⁽¹⁾
CCF4	PCA Module 4 interrupt flag. Set by hardware when a match or capture occurs. Must be cleared by software.
CCF3	PCA Module 3 interrupt flag. Set by hardware when a match or capture occurs. Must be cleared by software.
CCF2	PCA Module 2 interrupt flag. Set by hardware when a match or capture occurs. Must be cleared by software.
CCF1	PCA Module 1 interrupt flag. Set by hardware when a match or capture occurs. Must be cleared by software.
CCF0	PCA Module 0 interrupt flag. Set by hardware when a match or capture occurs. Must be cleared by software.

1. User software should not write 1s to reserved bits. These bits may be used in future 8051 family products to invoke new features. In that case, the reset or inactive value of the new bit will be 0, and its active value will be 1. The value read from a reserved bit is indeterminate.

The watchdog timer function is implemented in module 4 (See Figure 24).

The PCA interrupt system is shown in Figure 22.

Figure 22. PCA Interrupt System

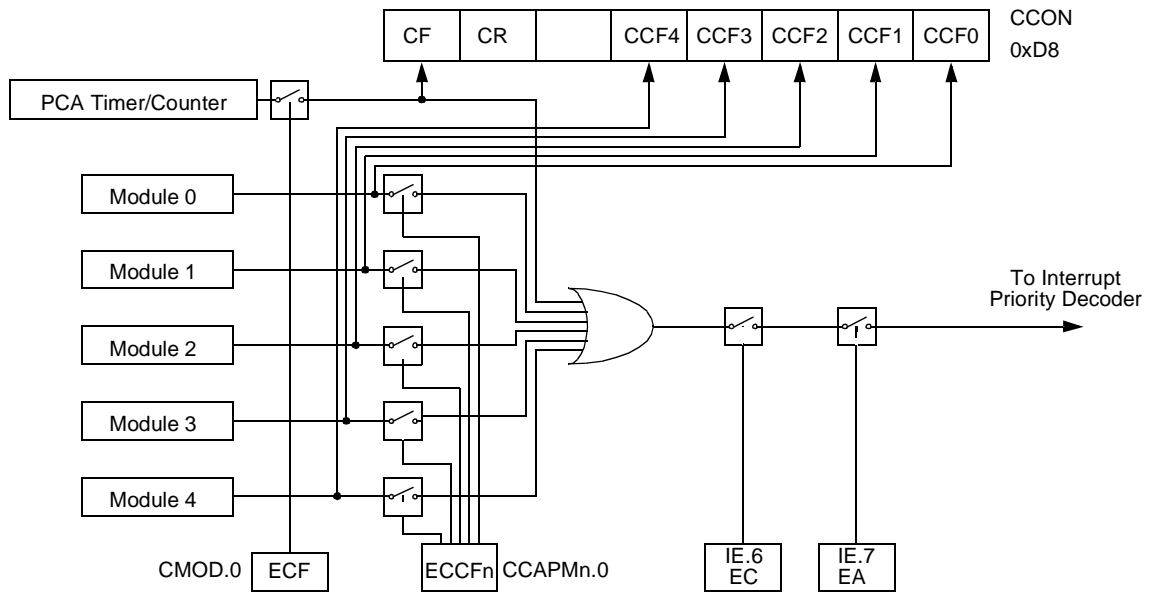

PCA Modules: each one of the five compare/capture modules has six possible functions. It can perform:

- 16-bit Capture, positive-edge triggered
- 16-bit Capture, negative-edge triggered
- 16-bit Capture, both positive and negative-edge triggered
- 16-bit Software Timer
- 16-bit High Speed Output
- 8-bit Pulse Width Modulator

In addition, module 4 can be used as a Watchdog Timer.

Each module in the PCA has a special function register associated with it. These registers are: CCAPM0 for module 0, CCAPM1 for module 1, etc. (See Table 24). The registers contain the bits that control the mode that each module will operate in.

- The ECCF bit (CCAPMn.0 where n = 0, 1, 2, 3, or 4 depending on the module) enables the CCF flag in the CCON SFR to generate an interrupt when a match or compare occurs in the associated module.
- PWM (CCAPMn.1) enables the pulse width modulation mode.
- The TOG bit (CCAPMn.2) when set causes the CEX output associated with the module to toggle when there is a match between the PCA counter and the module's capture/compare register.

- The match bit MAT (CCAPMn.3) when set will cause the CCFn bit in the CCON register to be set when there is a match between the PCA counter and the module's capture/compare register.
- The next two bits CAPN (CCAPMn.4) and CAPP (CCAPMn.5) determine the edge that a capture input will be active on. The CAPN bit enables the negative edge, and the CAPP bit enables the positive edge. If both bits are set both edges will be enabled and a capture will occur for either transition.
- The last bit in the register ECOM (CCAPMn.6) when set enables the comparator function.

Table 25 shows the CCAPMn settings for the various PCA functions.

Table 24. CCAPMn: PCA Modules Compare/Capture Control Registers

CCAPM0 = 0DAH
 CCAPM1 = 0DBH
 CCAPMn Address n = 0 - 4
 CCAPM2 = 0DCH
 CCAPM3 = 0DDH
 CCAPM4 = 0DEH

	-	ECOMn	CAPPn	CAPNn	MATn	TOGn	PWMm	ECCFn
Reset value	X	0	0	0	0	0	0	0

Symbol	Function
-	Not implemented, reserved for future use. ⁽¹⁾
ECOMn	Enable Comparator. ECOMn = 1 enables the comparator function.
CAPPn	Capture Positive, CAPPn = 1 enables positive edge capture.
CAPNn	Capture Negative, CAPNn = 1 enables negative edge capture.
MATn	Match. When MATn = 1, a match of the PCA counter with this module's compare/capture register causes the CCFn bit in CCON to be set, flagging an interrupt.
TOGn	Toggle. When TOGn = 1, a match of the PCA counter with this module's compare/capture register causes the CEXn pin to toggle.
PWMn	Pulse Width Modulation Mode. PWMn = 1 enables the CEXn pin to be used as a pulse width modulated output.
ECCFn	Enable CCF interrupt. Enables compare/capture flag CCFn in the CCON register to generate an interrupt.

1. User software should not write 1s to reserved bits. These bits may be used in future 8051 family products to invoke new features. In that case, the reset or inactive value of the new bit will be 0, and its active value will be 1. The value read from a reserved bit is indeterminate.

Table 25. PCA Module Modes (CCAPMn Registers)

ECOMn	CAPPn	CAPNn	MATn	TOGn	PWMm	ECCFn	Module Function
0	0	0	0	0	0	0	No Operation

ECOMn	CAPPn	CAPNn	MATn	TOGn	PWMm	ECCFn	Module Function
X	1	0	0	0	0	X	16-bit capture by a positive-edge trigger on CEXn
X	0	1	0	0	0	X	16-bit capture by a negative trigger on CEXn
X	1	1	0	0	0	X	16-bit capture by a transition on CEXn
1	0	0	1	0	0	X	16-bit Software Timer/Compare mode.
1	0	0	1	1	0	X	16-bit High Speed Output
1	0	0	0	0	1	0	8-bit PWM
1	0	0	1	X	0	X	Watchdog Timer (module 4 only)

There are two additional registers associated with each of the PCA modules. They are CCAPnH and CCAPnL and these are the registers that store the 16-bit count when a capture occurs or a compare should occur. When a module is used in the PWM mode these registers are used to control the duty cycle of the output (See Table 26 & Table 27)

Table 26. CCAPnH: PCA Modules Capture/Compare Registers High

CCAPnH Address n = 0 - 4
 CCAP0H = 0FAH
 CCAP1H = 0FBH
 CCAP2H = 0FCH
 CCAP3H = 0FDH
 CCAP4H = 0FEH

	7	6	5	4	3	2	1	0
Reset value	0	0	0	0	0	0	0	0

Table 27. CCAPnL: PCA Modules Capture/Compare Registers Low

CCAPnL Address n = 0 - 4
 CCAP0L = 0EAH
 CCAP1L = 0EBH
 CCAP2L = 0ECH
 CCAP3L = 0EDH
 CCAP4L = 0EEH

	7	6	5	4	3	2	1	0
Reset value	0	0	0	0	0	0	0	0

Table 28. CH: PCA Counter High

CH Address 0F9H

	7	6	5	4	3	2	1	0
Reset value	0	0	0	0	0	0	0	0

Table 29. CL: PCA Counter Low

CL
Address
0E9H

	7	6	5	4	3	2	1	0
Reset value	0	0	0	0	0	0	0	0

PCA Capture Mode

To use one of the PCA modules in the capture mode either one or both of the CCAPM bits CAPN and CAPP for that module must be set. The external CEX input for the module (on port 1) is sampled for a transition. When a valid transition occurs the PCA hardware loads the value of the PCA counter registers (CH and CL) into the module's capture registers (CCAPnL and CCAPnH). If the CCFn bit for the module in the CCON SFR and the ECCFn bit in the CCAPMn SFR are set then an interrupt will be generated (see Figure 23).

Figure 23. PCA Capture Mode

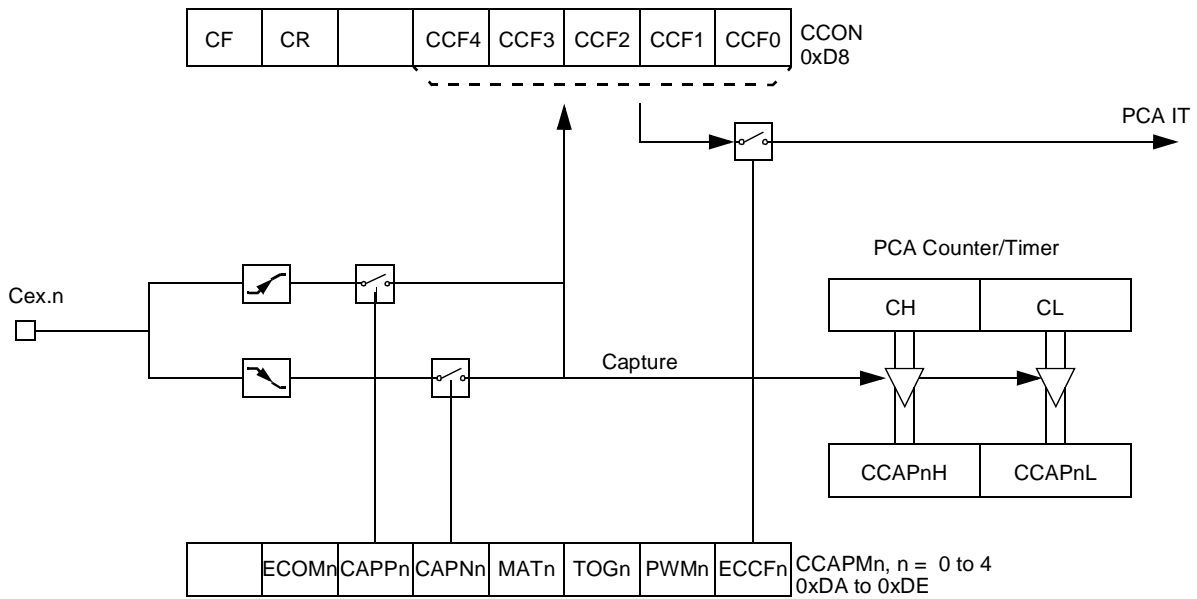

16-bit Software Timer/ Compare Mode

The PCA modules can be used as software timers by setting both the ECOM and MAT bits in the modules CCAPMn register. The PCA timer will be compared to the module's capture registers and when a match occurs an interrupt will occur if the CCFn (CCON SFR) and the ECCFn (CCAPMn SFR) bits for the module are both set (see Figure 24).

Figure 25. PCA High Speed Output Mode

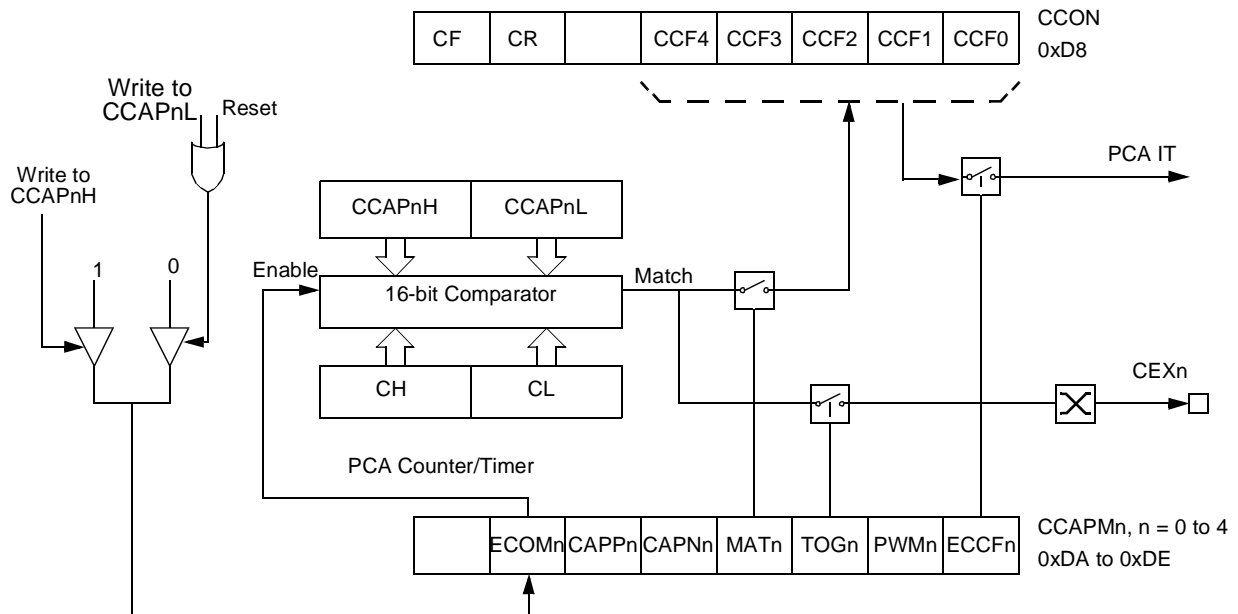

Before enabling ECOM bit, CCAPnL and CCAPnH should be set with a non zero value, other/wise an unwanted match could happen.

Once ECOM set, writing CCAPnL will clear ECOM so that an unwanted match doesn't occur while modifying the compare value. Writing to CCAPnH will set ECOM. For this reason, user software should write CCAPnL first, and then CCAPnH. Of course, the ECOM bit can still be controlled by accessing to CCAPMn register.

Pulse Width Modulator Mode

All of the PCA modules can be used as PWM outputs. Figure 26 shows the PWM function. The frequency of the output depends on the source for the PCA timer. All of the modules will have the same frequency of output because they all share the PCA timer. The duty cycle of each module is independently variable using the module's capture register CCAPL_n. When the value of the PCA CL SFR is less than the value in the module's CCAPL_n SFR the output will be low, when it is equal to or greater than the output will be high. When CL overflows from FF to 00, CCAPL_n is reloaded with the value in CCAPH_n. This allows updating the PWM without glitches. The PWM and ECOM bits in the module's CCAPM_n register must be set to enable the PWM mode.

Figure 26. PCA PWM Mode

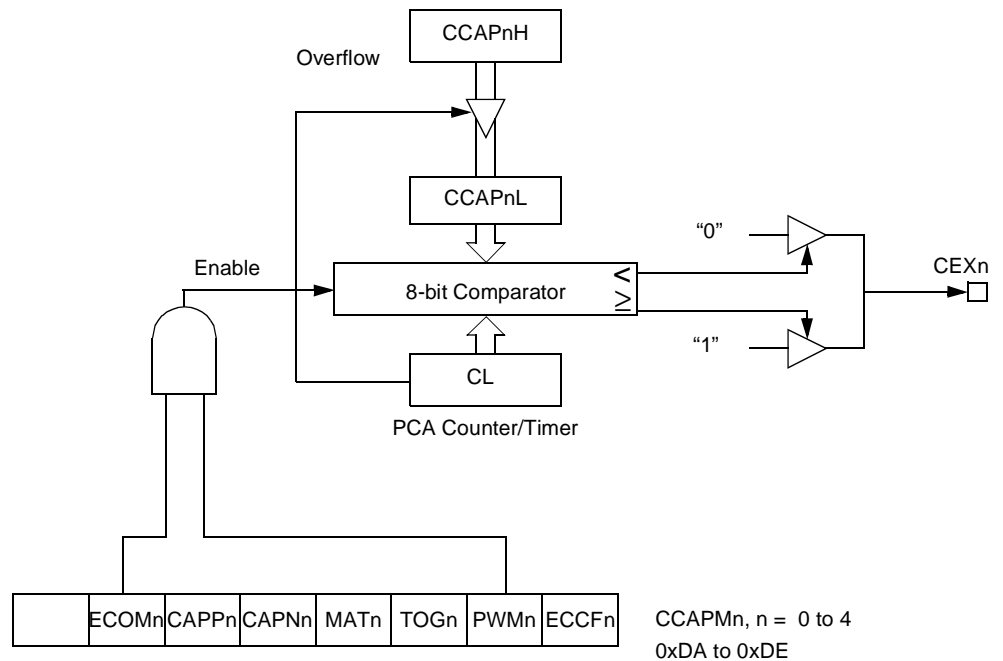

PCA Watchdog Timer

An on-board watchdog timer is available with the PCA to improve the reliability of the system without increasing chip count. Watchdog timers are useful for systems that are susceptible to noise, power glitches, or electrostatic discharge. Module 4 is the only PCA module that can be programmed as a watchdog. However, this module can still be used for other modes if the watchdog is not needed. Figure 24 shows a diagram of how the watchdog works. The user pre-loads a 16-bit value in the compare registers. Just like the other compare modes, this 16-bit value is compared to the PCA timer value. If a match is allowed to occur, an internal reset will be generated. This will not cause the RST pin to be driven high.

In order to hold off the reset, the user has three options:

1. Periodically change the compare value so it will never match the PCA timer.
2. Periodically change the PCA timer value so it will never match the compare values.
3. Disable the watchdog by clearing the WDTE bit before a match occurs and then re-enable it.

The first two options are more reliable because the watchdog timer is never disabled as in option #3. If the program counter ever goes astray, a match will eventually occur and cause an internal reset. The second option is also not recommended if other PCA modules are being used. Remember, the PCA timer is the time base for all modules; changing the time base for other modules would not be a good idea. Thus, in most applications the first solution is the best option.

This watchdog timer won't generate a reset out on the reset pin.

Interrupt System

The AT8xC5103 has a total of 5 interrupt vectors: one external interrupt $\overline{INT0}$, two timer interrupts (timers 0, 1), PCA and SPI. These interrupts are shown in Figure 27..

Figure 27. Interrupt Control System

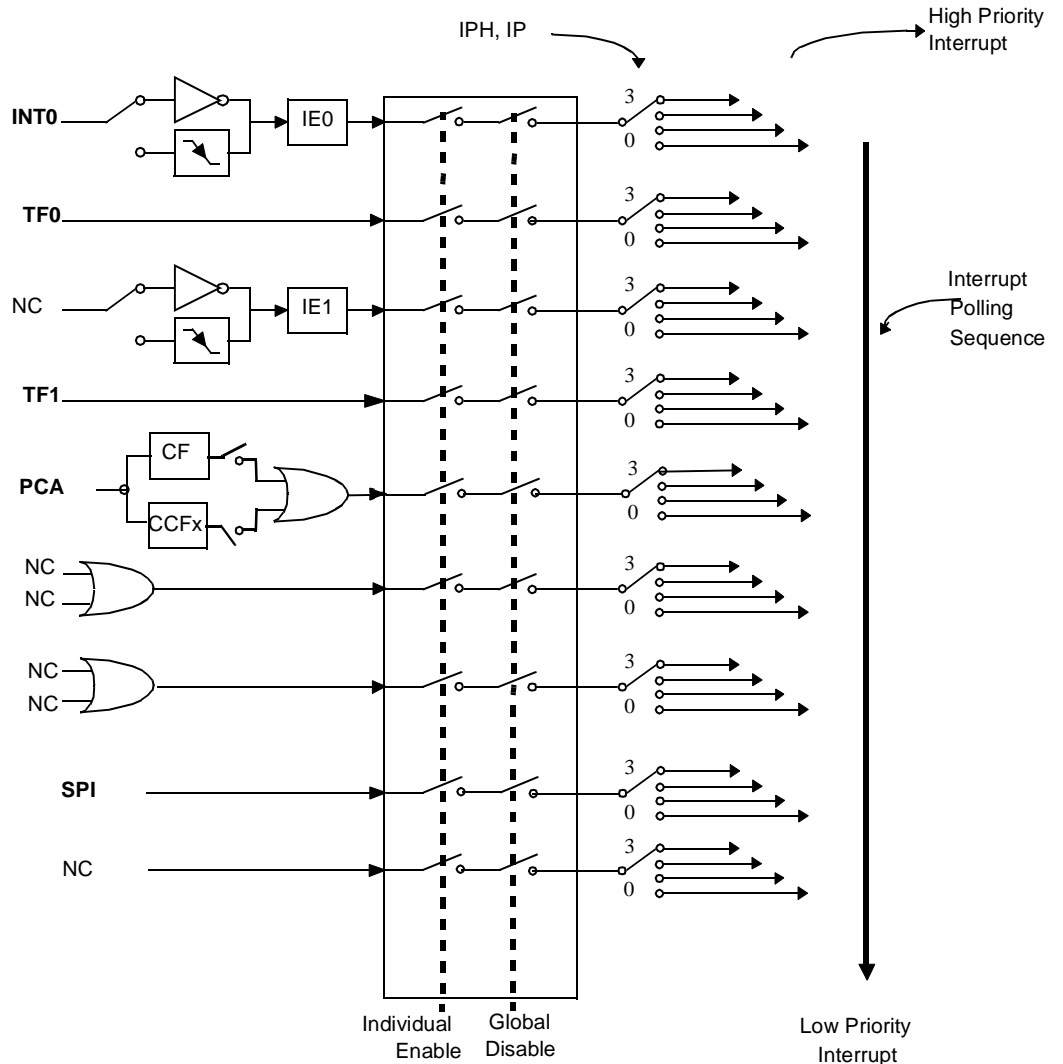

Each of the interrupt sources can be individually enabled or disabled by setting or clearing a bit in the Interrupt Enable register (see Table 31). This register also contains a global disable bit, which must be cleared to disable all interrupts at once.

Each interrupt source can also be individually programmed to one of four priority levels by setting or clearing a bit in the Interrupt Priority register (see Table 33) and in the Interrupt Priority High register (see Table 35). Table 30 shows the bit values and priority levels associated with each combination.

Table 30. Priority Level Bit Values

IPH.x	IPL.x	Interrupt Level Priority
0	0	0 (Lowest)
0	1	1
1	0	2
1	1	3 (Highest)

A low-priority interrupt can be interrupted by a high priority interrupt, but not by another low-priority interrupt. A high-priority interrupt can't be interrupted by any other interrupt source.

If two interrupt requests of different priority levels are received simultaneously, the request of higher priority level is serviced. If interrupt requests of the same priority level are received simultaneously, an internal polling sequence determines which request is serviced. Thus within each priority level there is a second priority structure determined by the polling sequence.

Interrupt Name	Interrupt Address Vector	Priority Number
External Interrupt (INT0)	0003h	1
Timer0 (TF0)	000Bh	2
Timer1 (TF1)	001Bh	3
PCA (CF or CCFn)	0033h	4
SPI	004Bh	5

Table 31. IE0 Register

IE0 (S:A8h)
Interrupt Enable Register

7	6	5	4	3	2	1	0
EA	EC	-	-	ET1	-	ET0	EX0

Bit Number	Bit Mnemonic	Description
7	EA	Enable All Interrupt Bit Clear to disable all interrupts. Set to enable all interrupts. If EA=1, each interrupt source is individually enabled or disabled by setting or clearing its interrupt enable bit.
6	EC	PCA Interrupt Enable Clear to disable the PCA interrupt. Set to enable the PCA interrupt.
5	-	Reserved The value read from this bit is indeterminate. Do not set this bit.
4	-	Reserved The value read from this bit is indeterminate. Do not set this bit.
3	ET1	Timer 1 overflow interrupt Enable bit Clear to disable timer 1 overflow interrupt. Set to enable timer 1 overflow interrupt.
2	-	Reserved The value read from this bit is indeterminate. Do not set this bit.
1	ET0	Timer 0 Overflow Interrupt Enable bit Clear to disable timer 0 overflow interrupt. Set to enable timer 0 overflow interrupt.
0	EX0	External Interrupt 0 Enable bit Clear to disable external interrupt 0. Set to enable external interrupt 0.

Reset Value = 00XX 0X00b

Bit addressable

Table 32. IE1 Register

IE1 (S:B1h)
Interrupt Enable Register

7	6	5	4	3	2	1	0
-	-	-	-	-	ESPI	-	-

Bit Number	Bit Mnemonic	Description
7	-	Reserved The value read from this bit is indeterminate. Do not set this bit.
6	-	Reserved The value read from this bit is indeterminate. Do not set this bit.
5	-	Reserved The value read from this bit is indeterminate. Do not set this bit.
4	-	Reserved The value read from this bit is indeterminate. Do not set this bit.
3	-	Reserved The value read from this bit is indeterminate. Do not set this bit.
2	ESPI	SPI Interrupt Enable bit Clear to disable the SPI interrupt. Set to enable the SPI interrupt.
1	-	Reserved The value read from this bit is indeterminate. Do not set this bit.
0	-	Reserved The value read from this bit is indeterminate. Do not set this bit.

Reset Value = XXXX X0XXb
No Bit addressable

Table 33. IPL0 Register
IPH0 - Interrupt Priority Low Register 0

7	6	5	4	3	2	1	0
-	PPCL	-	-	PT1L	-	PT0L	PX0L

Bit Number	Bit Mnemonic	Description
7	-	Reserved The value read from this bit is indeterminate. Do not set this bit.
6	PPCL	PCA Counter Interrupt Priority bit Refer to PPCH for priority level
5	-	Reserved The value read from this bit is indeterminate. Do not set this bit.
4	-	Reserved The value read from this bit is indeterminate. Do not set this bit.
3	PT1L	Timer 1 Overflow Interrupt Priority bit Refer to PT1H for priority level.
2	-	Reserved The value read from this bit is indeterminate. Do not set this bit.
1	PT0L	Timer 0 Overflow Interrupt Priority bit Refer to PT0H for priority level.
0	PX0L	External Interrupt 0 Priority bit Refer to PX0H for priority level.

Reset Value = X0XX 0X00b

Bit addressable.

Table 34. IPL1 Register

IPL1 (S:B2h)

IPL1 - Interrupt Priority Low Register 1

7	6	5	4	3	2	1	0
-	-	-	-	-	PSPIL	-	-

Bit Number	Bit Mnemonic	Description
7		
6	-	Reserved The value read from this bit is indeterminate. Do not set this bit.
5	-	Reserved The value read from this bit is indeterminate. Do not set this bit.
4	-	Reserved The value read from this bit is indeterminate. Do not set this bit.
3	-	Reserved The value read from this bit is indeterminate. Do not set this bit.
2	PSPIL	SPI Interrupt Priority Level Less Significant bit. Refer to PSPIH for priority level.
1	-	Reserved The value read from this bit is indeterminate. Do not set this bit.
0	-	Reserved The value read from this bit is indeterminate. Do not set this bit.

Reset Value = XXXX X0XXb

Not Bit addressable.

Table 35. IPH0 Register

IPH0 (S:B7h)

IPH0 - Interrupt Priority High Register 0

	7	6	5	4	3	2	1	0
	-	PPCH	-	-	PT1H	-	PT0H	PX0H

Bit Number	Bit Mnemonic	Description															
7	-	Reserved The value read from this bit is indeterminate. Do not set this bit.															
6	PPCH	PCA Counter Interrupt Priority Level Most Significant bit <table style="width: 100%; border-collapse: collapse;"> <tr> <td style="border: none;"><u>PPCH</u></td> <td style="border: none;"><u>PPCL</u></td> <td style="border: none;"><u>Priority level</u></td> </tr> <tr> <td style="border: none;">0</td> <td style="border: none;">0</td> <td style="border: none;">Lowest</td> </tr> <tr> <td style="border: none;">0</td> <td style="border: none;">1</td> <td style="border: none;"></td> </tr> <tr> <td style="border: none;">1</td> <td style="border: none;">0</td> <td style="border: none;"></td> </tr> <tr> <td style="border: none;">1</td> <td style="border: none;">1</td> <td style="border: none;">Highest priority</td> </tr> </table>	<u>PPCH</u>	<u>PPCL</u>	<u>Priority level</u>	0	0	Lowest	0	1		1	0		1	1	Highest priority
<u>PPCH</u>	<u>PPCL</u>	<u>Priority level</u>															
0	0	Lowest															
0	1																
1	0																
1	1	Highest priority															
5	-	Reserved The value read from this bit is indeterminate. Do not set this bit.															
4	-	Reserved The value read from this bit is indeterminate. Do not set this bit.															
3	PT1H	Timer 1 overflow interrupt Priority High bit <table style="width: 100%; border-collapse: collapse;"> <tr> <td style="border: none;"><u>PT1H</u></td> <td style="border: none;"><u>PT1L</u></td> <td style="border: none;"><u>Priority Level</u></td> </tr> <tr> <td style="border: none;">0</td> <td style="border: none;">0</td> <td style="border: none;">Lowest</td> </tr> <tr> <td style="border: none;">0</td> <td style="border: none;">1</td> <td style="border: none;"></td> </tr> <tr> <td style="border: none;">1</td> <td style="border: none;">0</td> <td style="border: none;"></td> </tr> <tr> <td style="border: none;">1</td> <td style="border: none;">1</td> <td style="border: none;">Highest</td> </tr> </table>	<u>PT1H</u>	<u>PT1L</u>	<u>Priority Level</u>	0	0	Lowest	0	1		1	0		1	1	Highest
<u>PT1H</u>	<u>PT1L</u>	<u>Priority Level</u>															
0	0	Lowest															
0	1																
1	0																
1	1	Highest															
2	-	Reserved The value read from this bit is indeterminate. Do not set this bit.															
1	PT0H	Timer 0 overflow interrupt Priority High bit <table style="width: 100%; border-collapse: collapse;"> <tr> <td style="border: none;"><u>PT0H</u></td> <td style="border: none;"><u>PT0L</u></td> <td style="border: none;"><u>Priority Level</u></td> </tr> <tr> <td style="border: none;">0</td> <td style="border: none;">0</td> <td style="border: none;">Lowest</td> </tr> <tr> <td style="border: none;">0</td> <td style="border: none;">1</td> <td style="border: none;"></td> </tr> <tr> <td style="border: none;">1</td> <td style="border: none;">0</td> <td style="border: none;"></td> </tr> <tr> <td style="border: none;">1</td> <td style="border: none;">1</td> <td style="border: none;">Highest</td> </tr> </table>	<u>PT0H</u>	<u>PT0L</u>	<u>Priority Level</u>	0	0	Lowest	0	1		1	0		1	1	Highest
<u>PT0H</u>	<u>PT0L</u>	<u>Priority Level</u>															
0	0	Lowest															
0	1																
1	0																
1	1	Highest															
0	PX0H	External interrupt 0 Priority High bit <table style="width: 100%; border-collapse: collapse;"> <tr> <td style="border: none;"><u>PX0H</u></td> <td style="border: none;"><u>PX0L</u></td> <td style="border: none;"><u>Priority Level</u></td> </tr> <tr> <td style="border: none;">0</td> <td style="border: none;">0</td> <td style="border: none;">Lowest</td> </tr> <tr> <td style="border: none;">0</td> <td style="border: none;">1</td> <td style="border: none;"></td> </tr> <tr> <td style="border: none;">1</td> <td style="border: none;">0</td> <td style="border: none;"></td> </tr> <tr> <td style="border: none;">1</td> <td style="border: none;">1</td> <td style="border: none;">Highest</td> </tr> </table>	<u>PX0H</u>	<u>PX0L</u>	<u>Priority Level</u>	0	0	Lowest	0	1		1	0		1	1	Highest
<u>PX0H</u>	<u>PX0L</u>	<u>Priority Level</u>															
0	0	Lowest															
0	1																
1	0																
1	1	Highest															

Reset Value = X0XX 0X00b

Not bit addressable

Table 36. IPH1 Register

IPH1 - Interrupt Priority High Register 1 (B3h)

	7	6	5	4	3	2	1	0
	-	-	-	-	-	PSPIH	-	-

Bit Number	Bit Mnemonic	Description															
7																	
6	-	Reserved The value read from this bit is indeterminate. Do not set this bit.															
5	-	Reserved The value read from this bit is indeterminate. Do not set this bit.															
4	-	Reserved The value read from this bit is indeterminate. Do not set this bit.															
3	-	Reserved The value read from this bit is indeterminate. Do not set this bit.															
2	PSPIH	SPI Interrupt Priority Level Most Significant bit <table border="1" style="width: 100%; border-collapse: collapse; margin-top: 5px;"> <thead> <tr> <th style="width: 15%;"><u>PSPIH</u></th> <th style="width: 15%;"><u>PSPIL Priority level</u></th> <th></th> </tr> </thead> <tbody> <tr> <td>0</td> <td>0</td> <td>Lowest</td> </tr> <tr> <td>0</td> <td>1</td> <td></td> </tr> <tr> <td>1</td> <td>0</td> <td></td> </tr> <tr> <td>1</td> <td>1</td> <td>Highest</td> </tr> </tbody> </table>	<u>PSPIH</u>	<u>PSPIL Priority level</u>		0	0	Lowest	0	1		1	0		1	1	Highest
<u>PSPIH</u>	<u>PSPIL Priority level</u>																
0	0	Lowest															
0	1																
1	0																
1	1	Highest															
1	-	Reserved The value read from this bit is indeterminate. Do not set this bit.															
0	-	Reserved The value read from this bit is indeterminate. Do not set this bit.															

Reset Value = XXXX X0XXb

Not bit addressable



Atmel Headquarters

Corporate Headquarters

2325 Orchard Parkway
San Jose, CA 95131
TEL 1(408) 441-0311
FAX 1(408) 487-2600

Europe

Atmel Sarl
Route des Arsenaux 41
Case Postale 80
CH-1705 Fribourg
Switzerland
TEL (41) 26-426-5555
FAX (41) 26-426-5500

Asia

Room 1219
Chinachem Golden Plaza
77 Mody Road Tsimhatsui
East Kowloon
Hong Kong
TEL (852) 2721-9778
FAX (852) 2722-1369

Japan

9F, Tonetsu Shinkawa Bldg.
1-24-8 Shinkawa
Chuo-ku, Tokyo 104-0033
Japan
TEL (81) 3-3523-3551
FAX (81) 3-3523-7581

Atmel Operations

Memory

2325 Orchard Parkway
San Jose, CA 95131
TEL 1(408) 441-0311
FAX 1(408) 436-4314

Microcontrollers

2325 Orchard Parkway
San Jose, CA 95131
TEL 1(408) 441-0311
FAX 1(408) 436-4314

La Chantrerie
BP 70602
44306 Nantes Cedex 3, France
TEL (33) 2-40-18-18-18
FAX (33) 2-40-18-19-60

ASIC/ASSP/Smart Cards

Zone Industrielle
13106 Rousset Cedex, France
TEL (33) 4-42-53-60-00
FAX (33) 4-42-53-60-01

1150 East Cheyenne Mtn. Blvd.
Colorado Springs, CO 80906
TEL 1(719) 576-3300
FAX 1(719) 540-1759

Scottish Enterprise Technology Park
Maxwell Building
East Kilbride G75 0QR, Scotland
TEL (44) 1355-803-000
FAX (44) 1355-242-743

RF/Automotive

Theresienstrasse 2
Postfach 3535
74025 Heilbronn, Germany
TEL (49) 71-31-67-0
FAX (49) 71-31-67-2340

1150 East Cheyenne Mtn. Blvd.
Colorado Springs, CO 80906
TEL 1(719) 576-3300
FAX 1(719) 540-1759

Biometrics/Imaging/Hi-Rel MPU/ High Speed Converters/RF Data- com

Avenue de Rochepleine
BP 123
38521 Saint-Egreve Cedex, France
TEL (33) 4-76-58-30-00
FAX (33) 4-76-58-34-80

e-mail

literature@atmel.com

Web Site

<http://www.atmel.com>

© Atmel Corporation 2002.

Atmel Corporation makes no warranty for the use of its products, other than those expressly contained in the Company's standard warranty which is detailed in Atmel's Terms and Conditions located on the Company's web site. The Company assumes no responsibility for any errors which may appear in this document, reserves the right to change devices or specifications detailed herein at any time without notice, and does not make any commitment to update the information contained herein. No licenses to patents or other intellectual property of Atmel are granted by the Company in connection with the sale of Atmel products, expressly or by implication. Atmel's products are not authorized for use as critical components in life support devices or systems.

ATMEL® is a registered trademark of Atmel.

Other terms and product names may be the trademarks of others.



Printed on recycled paper.

Hardware Byte: Lock bit

Table 37. Hardware Byte (HSB)

7	6	5	4	3	2	1	0
-	-	-	-	-	-	-	LB0
Bit Number	Bit Mnemonic	Description					
1:7	-	Reserved					
0	LB0	User Program EPROM Lock Bit Programmed (1) to protect memory from external read Unprogrammed (0), read or write is allowed					

The Lock system, when programmed, protects the on-chip program against software piracy. Only one level of protection for the on-chip code which when programmed are provided. If lock bit program, no read operation can be done, only CRC check.

This security bit is accessible only with hardware programmer.



Electrical Characteristics

Absolute Maximum Ratings⁽¹⁾

<p>Ambiant Temperature Under Bias:</p> <p>A = automotive..... -40°C to 125°C</p> <p>Storage Temperature -55°C to + 150°C</p> <p>Voltage on V_{CC} to V_{SS}.....-0.5V to + 3.63V</p> <p>Voltage on Any Pin to V_{SS}.....-0.5V to V_{CC} + 0.5V</p>	<p>Note: 1. Stresses at or above those listed under “Absolute Maximum Ratings” may cause permanent damage to the device. This is a stress rating only and functional operation of the device at these or any other conditions above those indicated in the operational sections of this specification is not implied. Exposure to absolute maximum rating conditions may affect device reliability.</p>
---	---

Power Consumption Measurement

Since the introduction of the first C51 device, every manufacturer made operating I_{CC} measurements under reset, which made sense for the designs where the CPU was running under reset. In our new devices, the CPU is no more active during reset, so the power consumption is very low but is not really representative of what will happen in the customer system. That’s why, while keeping measurements under Reset, we present a new way to measure the operating I_{CC}:

Using an internal test ROM, the following code is executed:

Label: SJMP Label (80 FE)

Ports 1 and 4 are disconnected, RST = V_{CC}, XTAL2 is not connected and XTAL1 is driven by the clock.

This is much more representative of the real operating I_{CC}.

DC Parameters

$T_A = -40^{\circ}\text{C}$ to $+125^{\circ}\text{C}$; $V_{SS} = 0\text{V}$; $V_{CC} = 3.3\text{V}$; $F = 0$ to 16 MHz

Table 38. DC Parameters for Low Voltage

Symbol	Parameter	Min	Typ	Max	Unit	Test Conditions
V_{IL}	Input Low Voltage	-0.5		$0.2 V_{CC} - 0.1$	V	
V_{IH}	Input High Voltage except XTAL1, RST	$0.2 V_{CC} + 0.9$		$V_{CC} + 0.5$	V	
V_{IH1}	Input High Voltage, XTAL1, RST	$0.7 V_{CC}$		$V_{CC} + 0.5$	V	
V_{hy}	Input hysteresis Voltage	145		400	mV	
V_{OL}	Output Low Voltage, ports 1 and 4 ⁽⁶⁾			0.4	V	$I_{OL} = 1.6\text{ mA}$
V_{OH}	Output High Voltage, ports 1 and 4. ⁽⁶⁾ Pseudo Bi-directional Mode	$V_{CC} - 1$			V	$I_{OH} = -1\text{ mA}$
T_r	Output Rise time (Push-pull mode)	8		1000	ns	Load = 10 pF
T_f	Output Fall time (Push-pull mode)	6		500	ns	Load = 10 pF
I_{LI}	Input Leakage Current			± 10	μA	$0.45\text{V} < V_{in} < V_{CC}$
R_{RST}	RST Pulldown Resistor	50	90 ⁽⁵⁾	200	k Ω	
CIO	Capacitance of I/O Buffer			15	pF	$F_c = 1\text{ MHz}$ $T_A = 25^{\circ}\text{C}$
I_{PD}	Power Down Current		10 ⁽⁵⁾	100	μA	
I_{CC} under RESET	Power Supply Current Maximum values, X1 mode: ⁽⁷⁾		to be confirmed		mA	$V_{CC} = 3.3\text{V}^{(1)}$
I_{CC} operating	Power Supply Current Maximum values, X1 mode: ⁽⁷⁾		to be confirmed	25 15	mA mA	$V_{CC} = 3.3\text{V}^{(8)}$ $F = 16\text{ Mhz}$ $F = 8\text{ Mhz}$
I_{CC} idle	Power Supply Current Maximum values, X1 mode: ⁽⁷⁾		to be confirmed		mA	$V_{CC} = 3.3\text{V}^{(2)}$
V_{RET}	Supply voltage during power-down mode	2			V	

- Notes:
- I_{CC} under reset is measured with all output pins disconnected; XTAL1 driven with T_{CLCH} , $T_{CHCL} = 5\text{ ns}$ (see Figure 32.), $V_{IL} = V_{SS} + 0.5\text{V}$
 $V_{IH} = V_{CC} - 0.5\text{V}$; XTAL2 N.C.; RST = V_{CC} . I_{CC} would be slightly higher if a crystal oscillator used
 - Idle I_{CC} is measured with all output pins disconnected; XTAL1 driven with T_{CLCH} , $T_{CHCL} = 5\text{ ns}$, $V_{IL} = V_{SS} + 0.5\text{V}$, $V_{IH} = V_{CC} - 0.5\text{V}$; XTAL2 N.C.; RST = V_{SS} (see Figure 30.).
 - Power Down I_{CC} is measured with all output pins disconnected; XTAL2 NC.; RST = V_{SS} (see Figure 31.).
 - Not Applicable
 - Typicals are based on a limited number of samples and are not guaranteed. The values listed are at room temperature and 5V.
 - If I_{OL} exceeds the test condition, V_{OL} may exceed the related specification. Pins are not guaranteed to sink current greater than the listed test conditions.
 - For other values, please contact your sales office.
 - Operating I_{CC} is measured with all output pins disconnected; XTAL1 driven with T_{CLCH} , $T_{CHCL} = 5\text{ ns}$ (see Figure 32.), $V_{IL} = V_{SS} + 0.5\text{V}$,
 $V_{IH} = V_{CC} - 0.5\text{V}$; XTAL2 N.C.; $\overline{\text{RST}} = V_{CC}$. The internal ROM runs the code 80 FE (label: SJMP label). I_{CC} would be slightly higher if a crystal oscillator is used.
 - $T_A = -40^{\circ}\text{C}$ to $+125^{\circ}\text{C}$; $V_{SS} = 0\text{V}$; $V_{CC} = 5\text{V}$; $F = 0$ to 16 MHz .
 - DC parameters will be fixed after full product characterization.

Figure 28. I_{CC} Test Condition, Under Reset

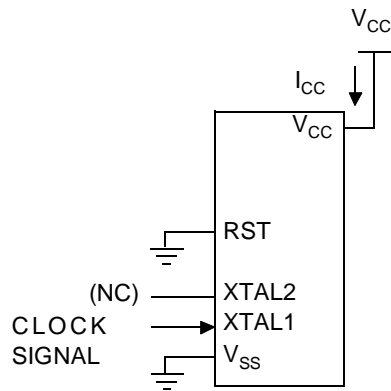

All other pins are disconnected.

Figure 29. Operating I_{CC} Test Condition

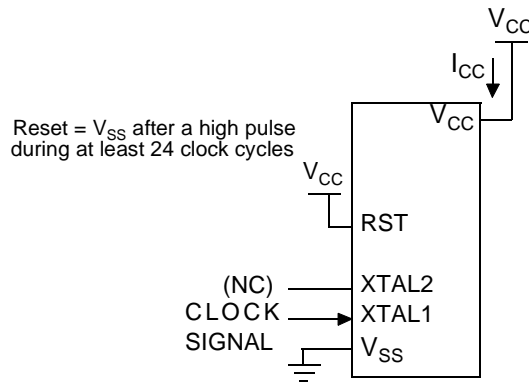

All other pins are disconnected.

Figure 30. I_{CC} Test Condition, Idle Mode

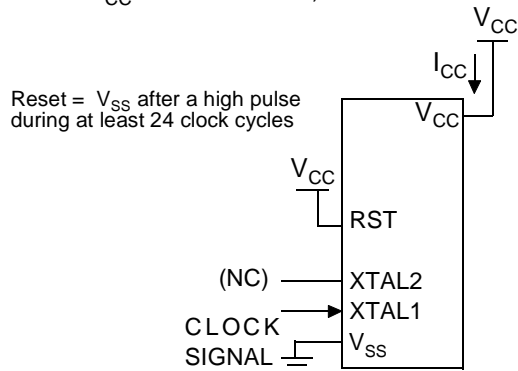

All other pins are disconnected

Figure 31. I_{CC} Test Condition, Power-Down Mode

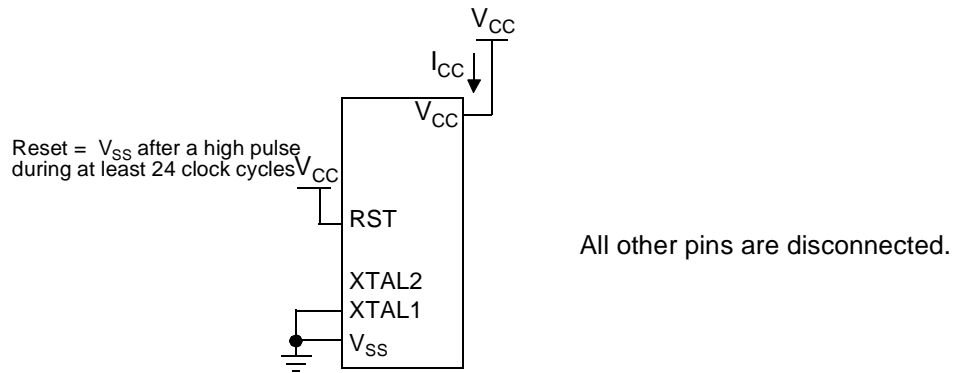
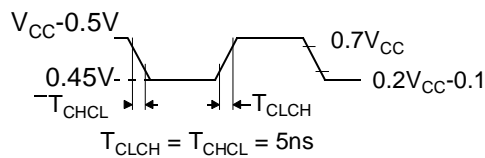

Figure 32. Clock Signal Waveform for I_{CC} Tests in Active and Idle Modes



AC Parameters

Explanation of the AC Symbols

Each timing symbol has 5 characters. The first character is always a “T” (stands for Time). The other characters, depending on their positions, stand for the name of a signal or the logical status of that signal. The following is a list of all the characters and what they stand for.

Example: T_{XHDV} = Time from clock rising edge to input data valid.

$T_A = -40^{\circ}C$ to $+125^{\circ}C$ (Automotive temperature range); $V_{SS} = 0V$; $3.135V < V_{CC} < 3.465V$

The maximum applicable load capacitance for Port 1 and 3 is 80 pF. Timings will be guaranteed if these capacitances are respected. Higher capacitance values can be used, but timings will then be degraded.

AC Testing Input/Output Waveforms

Figure 33. AC Testing Input/Output Waveforms

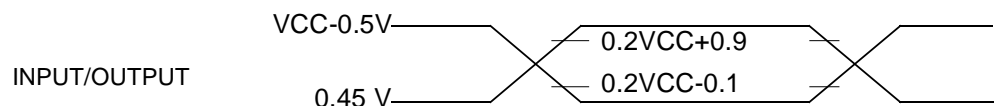

AC inputs during testing are driven at $V_{CC} - 0.5$ for a logic “1” and 0.45V for a logic “0”. Timing measurement are made at V_{IH} min for a logic “1” and V_{IL} max for a logic “0”.

Float Waveforms

Figure 34. Float Waveforms

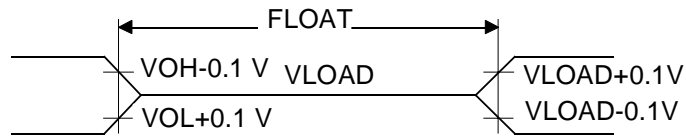

For timing purposes as port pin is no longer floating when a 100 mV change from load voltage occurs and begins to float when a 100 mV change from the loaded V_{OH}/V_{OL} level occurs. $I_{OL}/I_{OH} \geq \pm 20$ mA.

Clock Waveforms

Valid in normal clock mode. In X2 Mode XTAL2 signal must be changed to XTAL2 divided by 2.

Figure 35. Clock Waveforms

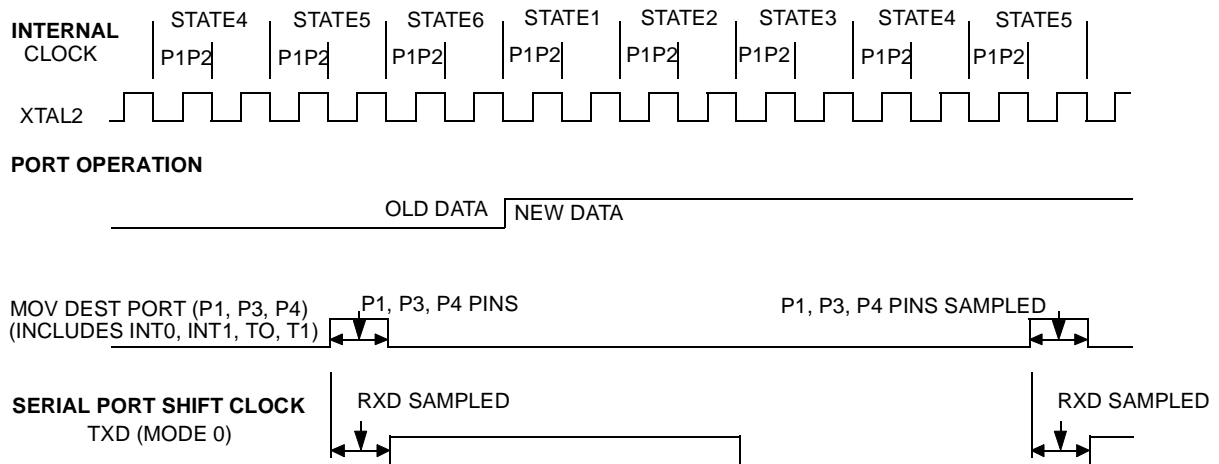

This diagram indicates when signals are clocked internally. The time it takes the signals to propagate to the pins, however, ranges from 25 to 125 ns. This propagation delay is dependent on variables such as temperature and pin loading. Propagation also varies from output to output and component. Typically though ($T_A=25^\circ\text{C}$ fully loaded) \overline{RD} and \overline{WR} propagation delays are approximately 50 ns. The other signals are typically 85 ns. Propagation delays are incorporated in the AC specifications.

Ordering Information

Part Number	Code Memory Size (Bytes)	Supply Voltage	Temperature Range	Max Frequency	Packing	Package
AT87C5103-IBSIL	12K OTP	2.7 - 5.5V	Industrial	16 MHz	Stick	SSOP16
AT87C5103-IBRIL	12K OTP	2.7 - 5.5V	Industrial	16 MHz	Reel	SSOP16
AT87C5103-ICSIL	12K OTP	2.7 - 5.5V	Industrial	16 MHz	Stick	SSOP24
AT87C5103-ICRIL	12K OTP	2.7 - 5.5V	Industrial	16 MHz	Reel	SSOP24
AT83C5103xxx-IBSIL	12K ROM	2.7 - 5.5V	Industrial	16 MHz	Stick	SSOP16
AT83C5103xxx-IBRIL	12K ROM	2.7 - 5.5V	Industrial	16 MHz	Reel	SSOP16
AT83C5103xxx-ICSIL	12K ROM	2.7 - 5.5V	Industrial	16 MHz	Stick	SSOP24
AT83C5103xxx-ICRIL	12K ROM	2.7 - 5.5V	Industrial	16 MHz	Reel	SSOP24

Package Drawing

SSOP 16 Leads

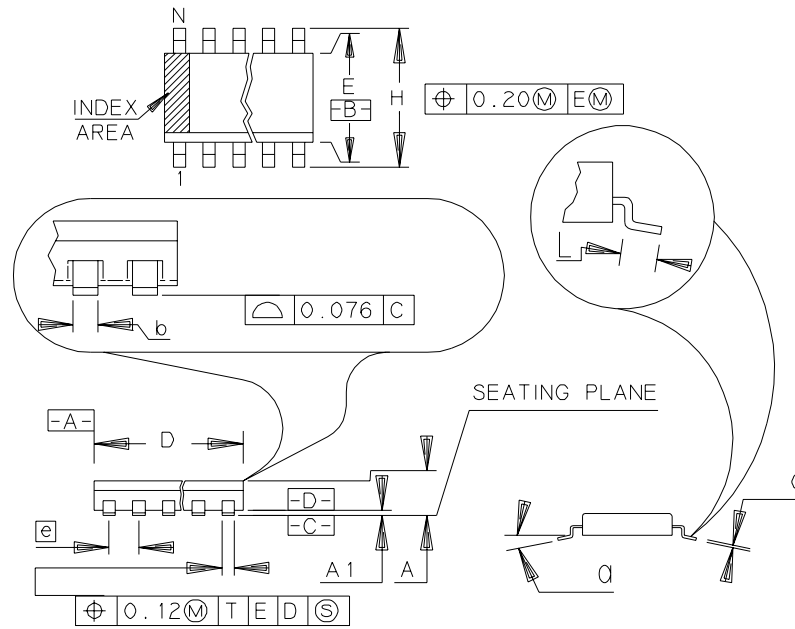

	MM		INCH	
	A	1.73	1.95	.068
A1	0.05	0.21	.002	.008
b	0.25	0.38	.010	.015
C	0.09	0.20	.004	.008
D	6.07	6.33	.239	.249
E	5.20	5.38	.205	.212
e	0.65	BSC	.0256	BSC
H	7.65	7.90	.301	.311
L	0.63	0.95	.025	.037
N	16		16	
α	0°		8°	

Package Drawing

SSOP 24 Leads

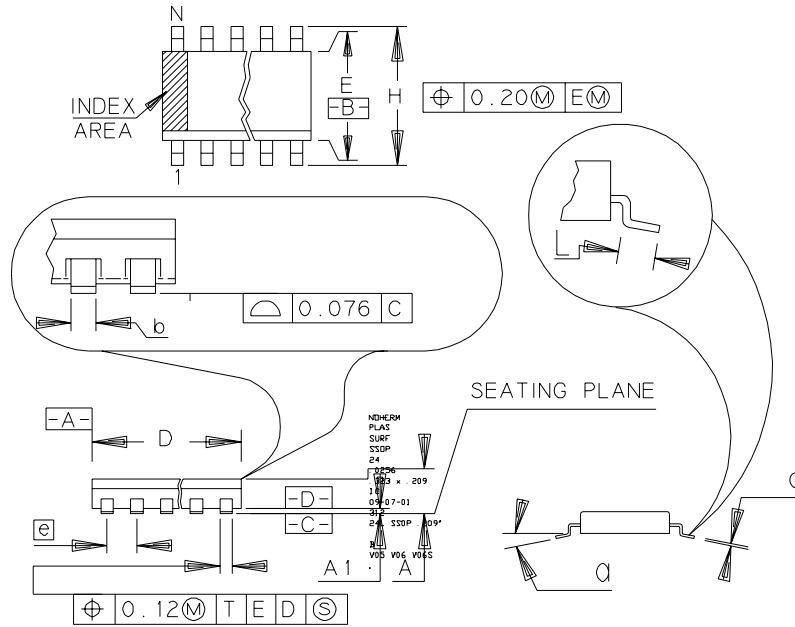

	MM		INCH	
	A	1.73	1.99	.068
A1	0.05	0.21	.002	.008
b	0.25	0.38	.010	.015
C	0.09	0.20	.004	.008
D	8.07	8.33	.318	.328
E	5.20	5.38	.205	.212
e	0.65	BSC	.0256	BSC
H	7.65	7.90	.301	.311
L	0.63	0.95	.025	.037
N	24		24	
a	0°	8°	0°	8°



Atmel Headquarters

Corporate Headquarters

2325 Orchard Parkway
San Jose, CA 95131
TEL 1(408) 441-0311
FAX 1(408) 487-2600

Europe

Atmel Sarl
Route des Arsenaux 41
Case Postale 80
CH-1705 Fribourg
Switzerland
TEL (41) 26-426-5555
FAX (41) 26-426-5500

Asia

Room 1219
Chinachem Golden Plaza
77 Mody Road Tsimhatsui
East Kowloon
Hong Kong
TEL (852) 2721-9778
FAX (852) 2722-1369

Japan

9F, Tonetsu Shinkawa Bldg.
1-24-8 Shinkawa
Chuo-ku, Tokyo 104-0033
Japan
TEL (81) 3-3523-3551
FAX (81) 3-3523-7581

Atmel Operations

Memory

2325 Orchard Parkway
San Jose, CA 95131
TEL 1(408) 441-0311
FAX 1(408) 436-4314

Microcontrollers

2325 Orchard Parkway
San Jose, CA 95131
TEL 1(408) 441-0311
FAX 1(408) 436-4314

La Chantrerie
BP 70602
44306 Nantes Cedex 3, France
TEL (33) 2-40-18-18-18
FAX (33) 2-40-18-19-60

ASIC/ASSP/Smart Cards

Zone Industrielle
13106 Rousset Cedex, France
TEL (33) 4-42-53-60-00
FAX (33) 4-42-53-60-01

1150 East Cheyenne Mtn. Blvd.
Colorado Springs, CO 80906
TEL 1(719) 576-3300
FAX 1(719) 540-1759

Scottish Enterprise Technology Park
Maxwell Building
East Kilbride G75 0QR, Scotland
TEL (44) 1355-803-000
FAX (44) 1355-242-743

RF/Automotive

Theresienstrasse 2
Postfach 3535
74025 Heilbronn, Germany
TEL (49) 71-31-67-0
FAX (49) 71-31-67-2340

1150 East Cheyenne Mtn. Blvd.
Colorado Springs, CO 80906
TEL 1(719) 576-3300
FAX 1(719) 540-1759

Biometrics/Imaging/Hi-Rel MPU/ High Speed Converters/RF Data- com

Avenue de Rochepleine
BP 123
38521 Saint-Egreve Cedex, France
TEL (33) 4-76-58-30-00
FAX (33) 4-76-58-34-80

e-mail

literature@atmel.com

Web Site

<http://www.atmel.com>

© Atmel Corporation 2002.

Atmel Corporation makes no warranty for the use of its products, other than those expressly contained in the Company's standard warranty which is detailed in Atmel's Terms and Conditions located on the Company's web site. The Company assumes no responsibility for any errors which may appear in this document, reserves the right to change devices or specifications detailed herein at any time without notice, and does not make any commitment to update the information contained herein. No licenses to patents or other intellectual property of Atmel are granted by the Company in connection with the sale of Atmel products, expressly or by implication. Atmel's products are not authorized for use as critical components in life support devices or systems.

ATMEL® is a registered trademark of Atmel.

Other terms and product names may be the trademarks of others.



Printed on recycled paper.