

Low Level and General Purpose Amplifiers

TYPE NO.	POLARITY	CASE	MAXIMUM RATINGS			H_{FE}				$V_{CE(SAT)}$		f_T min (MHz)	Cob max (pF)	N.F. max (dB)
			P_d (mW)	I_C (mA)	V_{CEO} (V)	min	max	I_C (mA)	VCE (V)	max (V)	I_C (mA)			
BC 251	P	TO-92F	300	100	45	125	900▲*	2	5	0.3	10	80	6	10
BC 252	P	TO-92F	300	100	25	125	900▲*	2	5	0.3	10	80	6	10
BC 253	P	TO-92F	300	100	25	125	900▲*	2	5	0.3	10	80	6	4
BC 256	P	TO-92F	300	100	64	125	500*	2	5	0.5	100	130+	6	10
BC 257	P	TO-92B	300	100	45	70	450*	2	5	0.3	10	130	6	10
BC 258	P	TO-92B	300	100	25	70	800*	2	5	0.3	10	130	6	10
BC 259	P	TO-92B	300	100	20	200	800*	2	5	0.3	10	130	6	4
BC 260	P	TO-18	300	100	20	35	600*	1	1	0.4+	30	100	6	—
BC 261	P	TO-18	300	100	45	125	900▲*	2	5	0.3	10	100	6	10
BC 262	P	TO-18	300	100	25	125	900▲*	2	5	0.3	10	100	6	10
BC 263	P	TO-18	300	100	25	125	900▲*	2	5	0.3	10	100	6	4
BC 266	P	TO-18	300	100	64	110	450*	2	5	0.3	10	150+	6	10
BC 267	N	TO-18	400	1000	45	110	450*	2	5	0.3	100	150	8.6+	3+
BC 268	N	TO-18	400	1000	20	110	800*	2	5	0.3	100	150	8.6+	3+
BC 269	N	TO-18	400	1000	30	220	800*	2	5	0.3	100	150	8.6+	4
BC 280	N	TO-18	360	100	40	180	600	1	5	0.7	10	—	2.8+	3
BC 282	N	TO-18	400	600	30	50	300	50	5	1	300	100	10	—
BC 283	P	TO-18	400	600	30	40	270	50	5	1	300	80+	7	—
BC 307	P	TO-92F	300	100	45	70	450*	2	5	0.3	10	100	6	10
BC 308	P	TO-92F	300	100	25	70	800*	2	5	0.3	10	100	6	10
BC 309	P	TO-92F	300	100	20	200	800*	2	5	0.3	10	100	6	4
BC 315	P	TO-92F	300	100	35	100	350	2	5	0.6	100	200	5+	2
BC 315L	P	TO-92B	300	100	35	100	350	2	5	0.6	100	200	5+	2
BC 317	N	TO-92A	310	150	45	110	450*	2	5	0.5	100	100	4	6
BC 318	N	TO-92A	310	150	30	110	800*	2	5	0.5	100	100	7	6
BC 319	N	TO-92A	310	150	20	200	800*	2	5	0.5	100	100	4	4
BC 320	P	TO-92A	310	150	45	70	450*	2	5	0.3	10	100	4	6
BC 321	P	TO-92A	310	150	30	70	800*	2	5	0.3	10	100	4	6
BC 322	P	TO-92A	310	150	20	200	800*	2	5	0.3	10	100	4	4
BC 326	P	TO-18	360	50	60	100	500	0.01	5	0.35	1	60	9	—
BC 330	N	TO-92F	250	30	45	220	—*	2	5	1	10	100	3	2
BC 332	N	TO-92F	250	30	45	100	—*	2	5	1	10	100	3	6
BC 333	N	TO-92F	310	50	25	100	1000*	0.1	5	0.6	10	50	4	—
BC 334	P	TO-92F	310	50	25	100	1000*	0.1	5	0.6	10	50	4	—
BC 335	N	TO-92F	310	50	25	100	1000*	0.1	5	0.6	10	50	4	—
BC 336	P	TO-92F	310	50	25	100	1000*	0.1	5	0.6	10	50	4	—
BC 347	N	TO-92A	300	100	45	40	450*	2	5	0.25	10	125	4	10
BC 348	N	TO-92A	300	100	30	40	450*	2	5	0.25	10	125	4	10
BC 349	N	TO-92A	300	100	20	40	450*	2	5	0.25	10	125	4	10
BC 350	N	TO-92A	300	100	45	40	450*	2	5	0.25	10	125	4	10
BC 351	P	TO-92A	300	100	30	40	450*	2	5	0.25	10	125	4	10
BC 352	P	TO-92A	300	100	20	40	450*	2	5	0.25	10	125	4	10
BC 357	P	TO-92F	310	100	25	100	500	10	10	0.25	10	200	10	—
BC 358	N	TO-92F	310	100	25	100	500	10	10	0.25	10	125	10	—
BC 382	N	TO-92F	300	100	45	100	900*	2	5	0.6	100	150	5	6
BC 382L	N	TO-92B	300	100	45	100	900*	2	5	0.6	100	150	5	6
BC 383	N	TO-92F	300	100	30	100	900*	2	5	0.6	100	150	5	6
BC 383L	N	TO-92B	300	100	30	100	900*	2	5	0.6	100	150	5	6
BC 384	N	TO-92F	300	100	30	250	900*	2	5	0.6	100	150	5	4
BC 384L	N	TO-92B	300	100	30	250	900*	2	5	0.6	100	150	5	4
BC 385	N	TO-92F	300	100	45	100	480	2	5	0.6	100	150	5	—
BC 386	N	TO-92F	300	100	20	100	850	2	5	0.6	100	150	5	—
BC 413	N	TO-92F	300	100	30	180	800*	2	5	0.6	100	200+	2.7+	2.5
BC 414	N	TO-92F	300	100	45	180	800*	2	5	0.6	100	200+	2.7+	2.5
BC 415	P	TO-92F	300	100	35	120	800*	2	5	0.6	100	200+	2.7+	2

* H_{FE} groupings available ▲ hfe @ 1 KHz + Typical value

Mechanical Outlines

TO-92

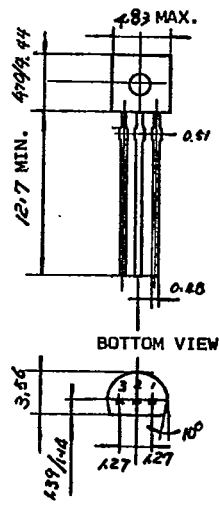

LEAD CODE	1	2	3
A	E	B	C
B	E	C	B
C	B	E	C
D	B	C	E
E*	C	E	B
F*	C	B	E
BA*	K	A	G
BF*	A	G	K
DA	B	G	D
DB	B	D	G
DC	D	G	B
DD	D	G	B
DE*	G	B	D
DF*	G	D	B
VOLTAGE REGULATOR			
D	O	G	L

*ALL LEAD FORM TO MELF-001 UNLESS OTHERWISE NOTED.

TO-92 LEAD FORM

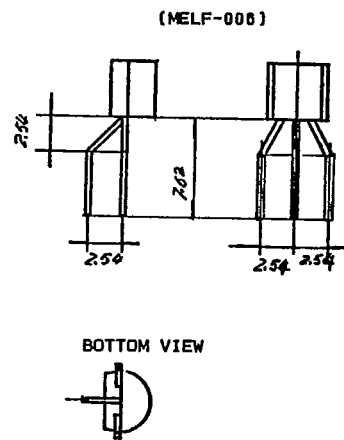
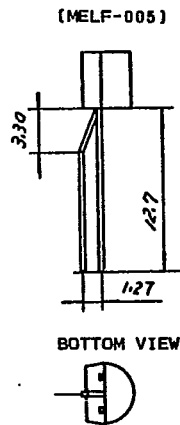
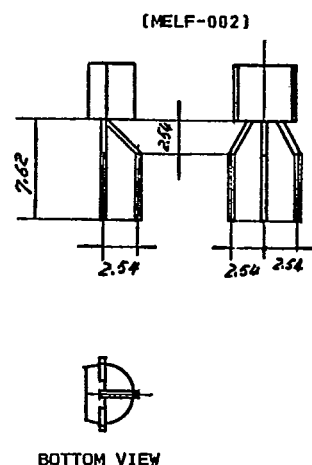
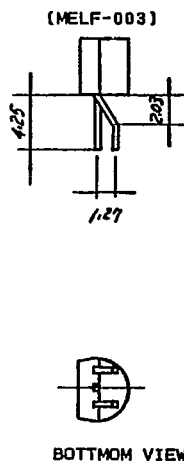
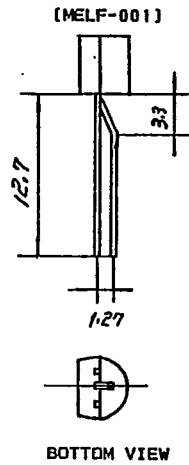

ALL DIMENSIONS IN mm

Mechanical Outlines

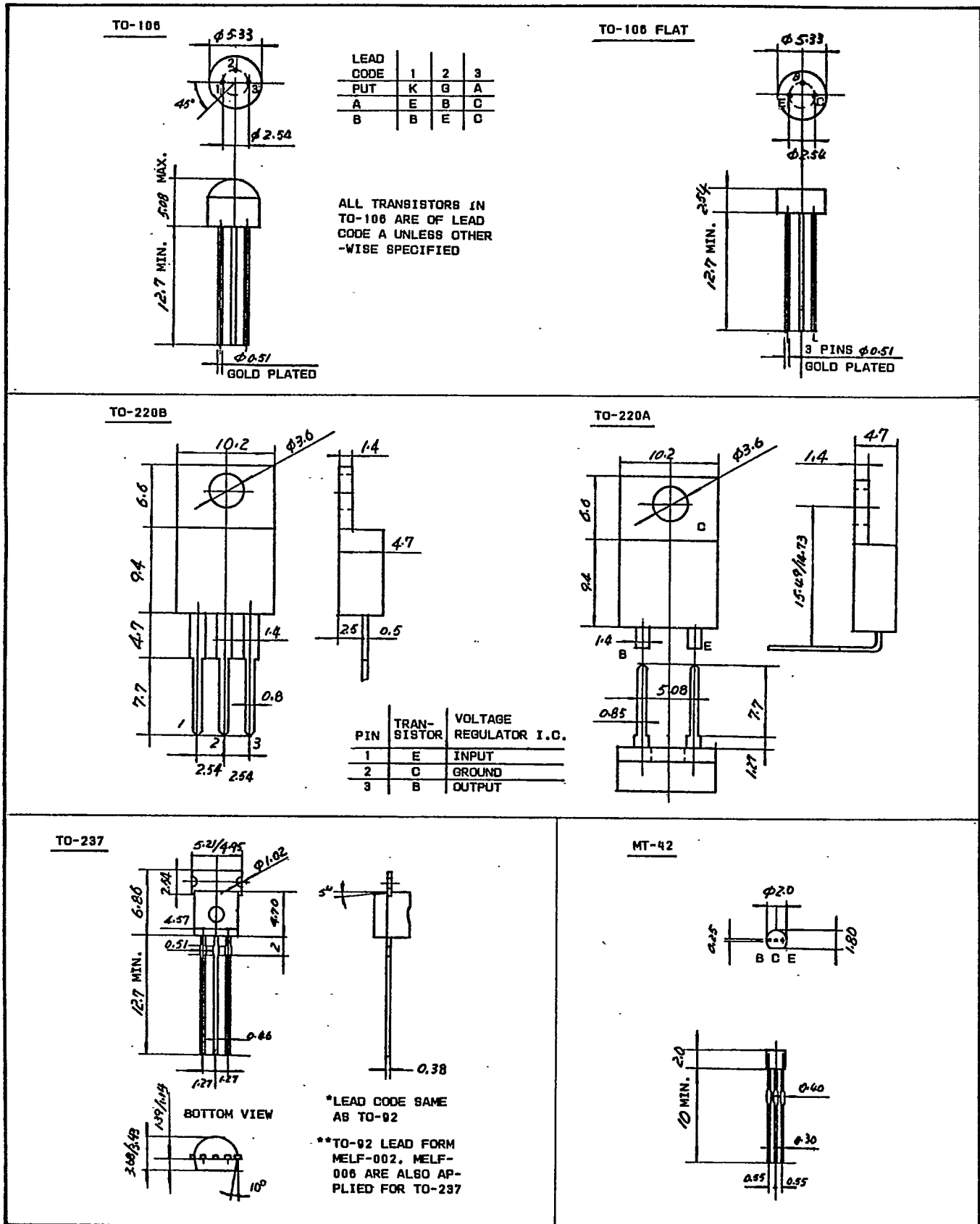

ALL DIMENSIONS IN mm

Mechanical Outlines

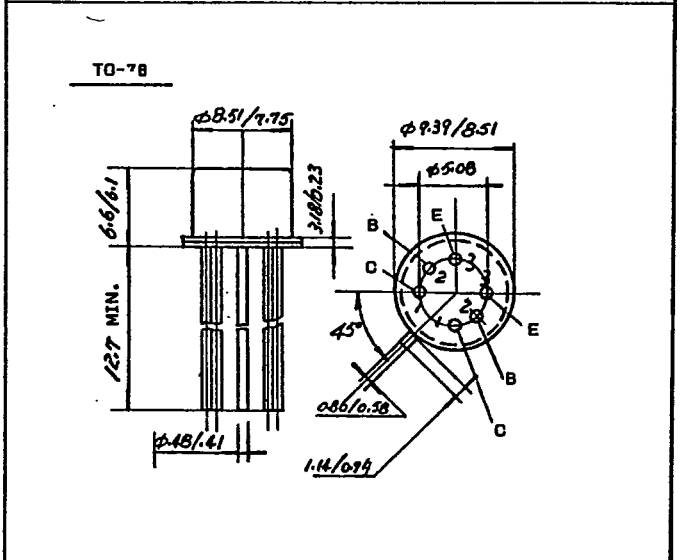
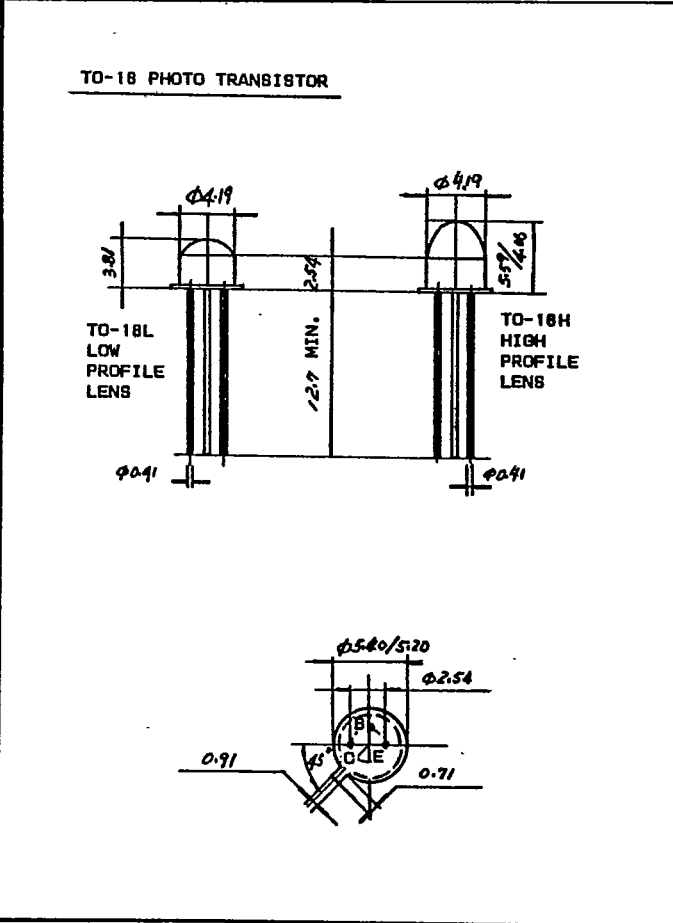
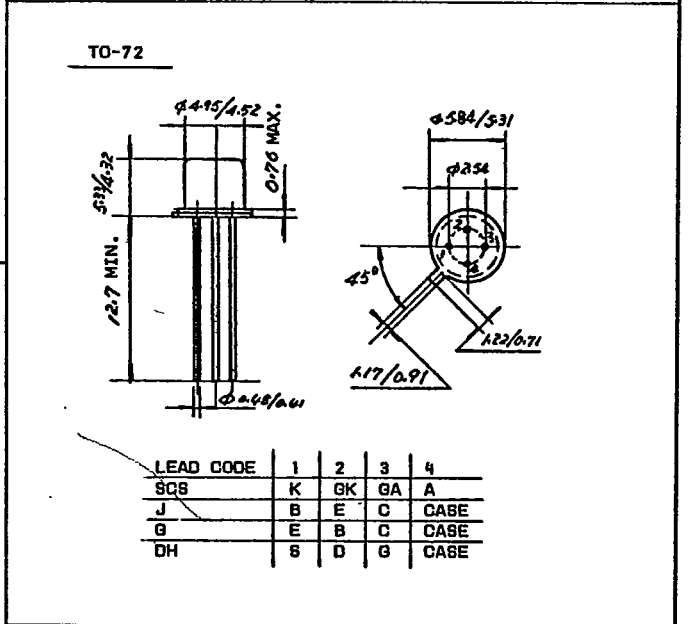
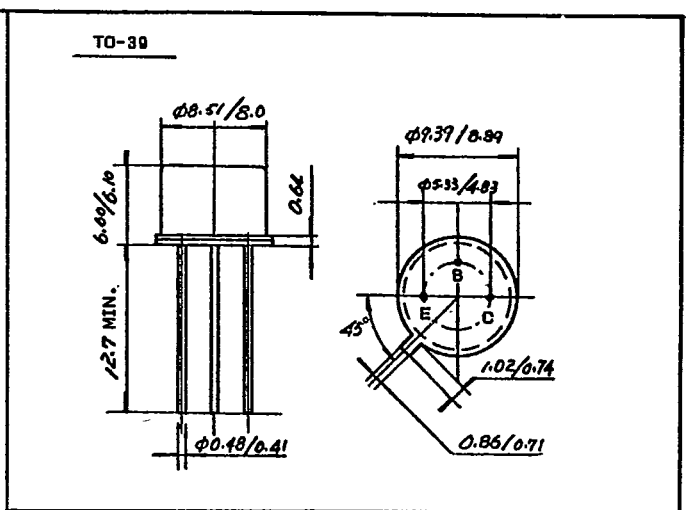
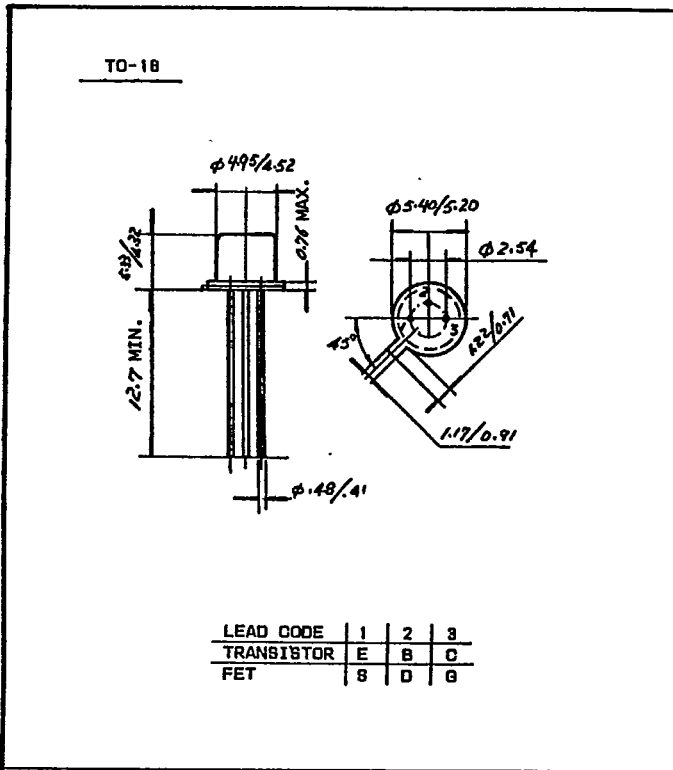

ALL DIMENSIONS IN mm