

2N/PN/SST4391 Series

N-Channel JFETs

2N4391	PN4391	SST4391
2N4392	PN4392	SST4392
2N4393	PN4393	SST4393

Product Summary

Part Number	V _{GS(off)} (V)	r _{DS(on)} Max (Ω)	I _{D(off)} Typ (pA)	t _{ON} Typ (ns)
2N/PN/SST4391	-4 to -10	30	5	4
2N/PN/SST4392	-2 to -5	60	5	4
2N/PN/SST4393	-0.5 to -3	100	5	4

Features

- Low On-Resistance: 4391 < 30 Ω
- Fast Switching—t_{ON}: 4 ns
- High Off-Isolation: I_{D(off)} with Low Leakage
- Low Capacitance: < 3.5 pF
- Low Insertion Loss

Benefits

- Low Error Voltage
- High-Speed Analog Circuit Performance
- Negligible “Off-Error,” Excellent Accuracy
- Good Frequency Response, Low Glitches
- Eliminates Additional Buffering

Applications

- Analog Switches
- Choppers
- Sample-and-Hold
- Normally “On” Switches
- Current Limiters
- Commutators

Description

The 2N/PN/SST4391 series features many of the superior characteristics of JFETs which make it a good choice for demanding analog switching applications and for specialized amplifier circuits.

The 2N series hermetically-sealed TO-206AA (TO-18) can be available with processing per MIL-S-19500 (see Military Information). Both the PN, TO-226AA (TO-92), and SST, TO-236 (SOT-23), series are available in tape-and-reel for automated assembly (see Packaging Information). For similar dual products, see the 2N5564/5565/5566 data sheet.

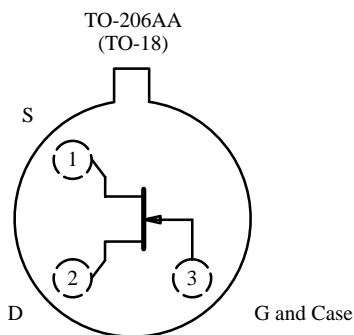

Top View

2N4391
2N4392
2N4393

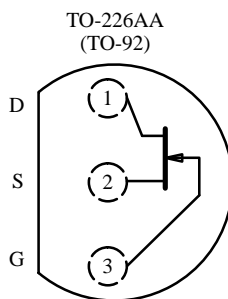

Top View

PN4391
PN4392
PN4393

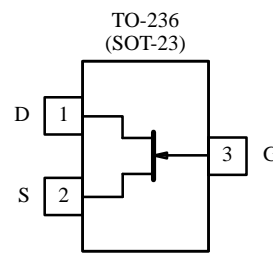

Top View

SST4391 (CA)*
SST4392 (CB)*
SST4393 (CC)*

*Marking Code for TO-236

Updates to this data sheet may be obtained via facsimile by calling Siliconix FaxBack, 1-408-970-5600. Please request FaxBack document #70241. Applications information may also be obtained via FaxBack, request document #70597 and 70599.

2N/PN/SST4391 Series

Absolute Maximum Ratings

Gate-Drain, Gate-Source Voltage:

(2N/PN Prefixes)	-40 V
(SST Prefix)	-35 V

Gate Current 50 mA

Lead Temperature 300 °C

Storage Temperature : (2N Prefix) -65 to 200 °C
 (PN/SST Prefixes) -55 to 150 °C

Operating Junction Temperature :

(2N Prefix)	-55 to 200 °C
(PN/SST Prefixes)	-55 to 150 °C

Power Dissipation :

(2N Prefix) ^a	(T _C = 25 °C) 1800 mW
(PN/SST Prefixes) ^b	350 mW

Notes

- a. Derate 10 mW/°C above 25 °C
- b. Derate 2.8 mW/°C above 25 °C

Specifications^a

Parameter	Symbol	Test Conditions	Typ ^b	Limits						Unit	
				4391		4392		4393			
				Min	Max	Min	Max	Min	Max		
Static											
Gate-Source Breakdown Voltage	V _{(BR)GSS}	I _G = -1 μA, V _{DS} = 0 V	-55	-40		-40		-40		V	
Gate-Source Cutoff Voltage	V _{GS(off)}	V _{DS} = 20 V 2N/PN: I _D = 1 nA		-4	-10	-2	-5	-0.5	-3	V	
		V _{DS} = 15 V SST: I _D = 10 nA									
Saturation Drain Current ^c	I _{DSS}	V _{DS} = 20 V, V _{GS} = 0 V	2N	50	150	25	75	5	30	mA	
			PN	50	150	25	100	5	60		
			SST	50		25		5			
Gate Reverse Current	I _{GSS}	V _{GS} = -20 V V _{DS} = 0 V	2N/SST	-5	-100		-100		-100	pA	
			PN	-5	-1000		-1000		-1000		
			2N: T _A = 150 °C	-13	-200		-200		-200	nA	
			PN: T _A = 100 °C	-1	-200		-200		-200		
	SST: T _A = 125 °C	-3									
Gate Operating Current	I _G	V _{DG} = 15 V, I _D = 10 mA	-5								
Drain Cutoff Current	I _{D(off)}	V _{DS} = 20 V	2N: V _{GS} = -5 V	5					100	pA	
			2N: V _{GS} = -7 V	5			100				
			2N: V _{GS} = -12 V	5	100						
			PN: V _{GS} = -5 V	0.005					1	nA	
			PN: V _{GS} = -7 V	0.005			1				
			PN: V _{GS} = -12 V	0.005	1						
			SST V _{DS} = 10 V, V _{GS} = -10 V	5	100		100		100	pA	
			V _{DS} = 20 V T _A = 150 °C	2N: V _{GS} = -5 V	13					200	nA
		2N: V _{GS} = -7 V		13			200				
		2N: V _{GS} = -12 V		13	200						
	V _{DS} = 20 V T _A = 100 °C	PN: V _{GS} = -5 V	1					200			
PN: V _{GS} = -7 V		1			200						
PN: V _{GS} = -12 V		1	200								
	V _{DS} = 10 V T _A = 125 °C	SST: V _{GS} = -10 V	3								
Drain-Source On-Voltage	V _{DS(on)}	V _{GS} = 0 V	I _D = 3 mA	0.25					0.4	V	
			I _D = 6 mA	0.3			0.4				
			I _D = 12 mA	0.35	0.4						

2N/PN/SST4391 Series

Specifications^a

Parameter	Symbol	Test Conditions	Typ ^b	Limits						Unit	
				4391		4392		4393			
				Min	Max	Min	Max	Min	Max		
Static (Cont'd)											
Drain-Source On-Resistance	$r_{DS(on)}$	$V_{GS} = 0\text{ V}, I_D = 1\text{ mA}$			30		60		100	Ω	
Gate-Source Forward Voltage	$V_{GS(F)}$	$I_G = 1\text{ mA}$ $V_{DS} = 0\text{ V}$	2N	0.7		1		1		1	V
			PN/SST	0.7							
Dynamic											
Common-Source Forward Transconductance	g_{fs}	$V_{DS} = 20\text{ V}, I_D = 1\text{ mA}, f = 1\text{ kHz}$		6							mS
Common-Source Output Conductance	g_{os}			25							μS
Drain-Source On-Resistance	$r_{DS(on)}$	$V_{GS} = 0\text{ V}, I_D = 0\text{ mA}, f = 1\text{ kHz}$			30		60		100	Ω	
Common-Source Input Capacitance	C_{iss}	$V_{DS} = 20\text{ V}, V_{GS} = 0\text{ V}$ $f = 1\text{ MHz}$	2N	12		14		14		14	
			PN	12		16		16		16	
			SST	13							
Common-Source Reverse Transfer Capacitance	C_{rss}	$V_{DS} = 0\text{ V}$ $f = 1\text{ MHz}$	2N: $V_{GS} = -5\text{ V}$	3.3						3.5	pF
			2N: $V_{GS} = -7\text{ V}$	3.2				3.5			
			2N: $V_{GS} = -12\text{ V}$	2.8		3.5					
			PN: $V_{GS} = -5\text{ V}$	3.5						5	
			PN: $V_{GS} = -7\text{ V}$	3.4				5			
			PN: $V_{GS} = -12\text{ V}$	3.0		5					
			SST: $V_{GS} = -5\text{ V}$	3.6							
SST: $V_{GS} = -7\text{ V}$	3.5										
SST: $V_{GS} = -12\text{ V}$	3.1										
Equivalent Input Noise Voltage	\bar{e}_n	$V_{DS} = 10\text{ V}, I_D = 10\text{ mA}$ $f = 1\text{ kHz}$		3						$\text{nV}/\sqrt{\text{Hz}}$	
Switching											
Turn-On Time	$t_{d(on)}$	$V_{DD} = 10\text{ V}$ $V_{GS(H)} = 0\text{ V}$ See Switching Circuit	2N/PN	2		15		15		15	ns
			SST	2							
	t_r		2N/PN	2		5		5		5	
			SST	2							
Turn-Off Time	$t_{d(off)}$		2N/PN	6		20		35		50	
			SST	6							
	t_f	2N/PN	13		15		20		30		
		SST	13								

Notes

- $T_A = 25^\circ\text{C}$ unless otherwise noted.
- Typical values are for DESIGN AID ONLY, not guaranteed nor subject to production testing.
- Pulse test: $PW \leq 300\ \mu\text{s}$ duty cycle $\leq 3\%$.

NCB

2N/PN/SST4391 Series

Typical Characteristics

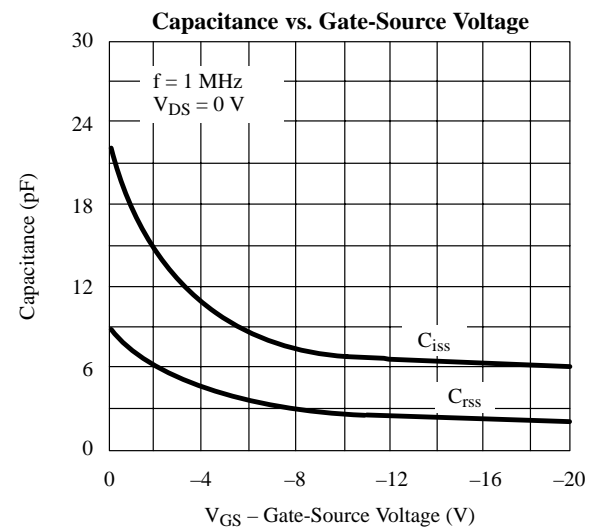
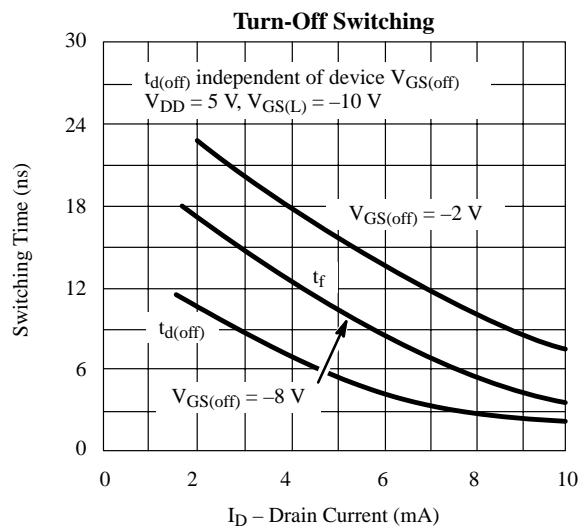
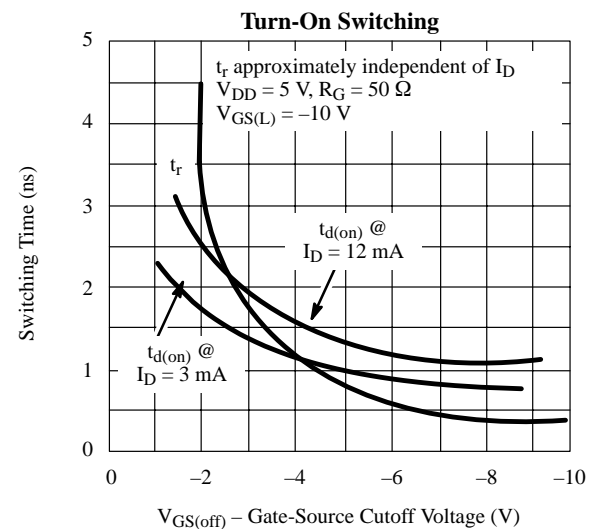
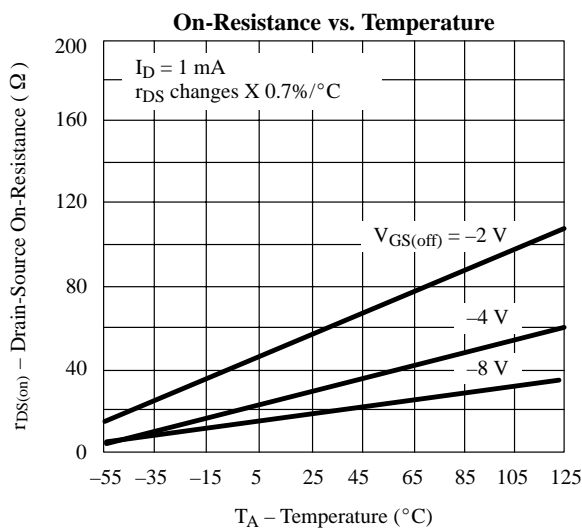
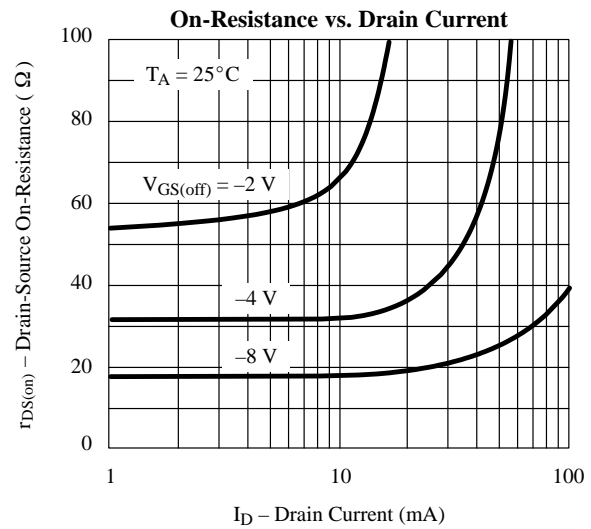
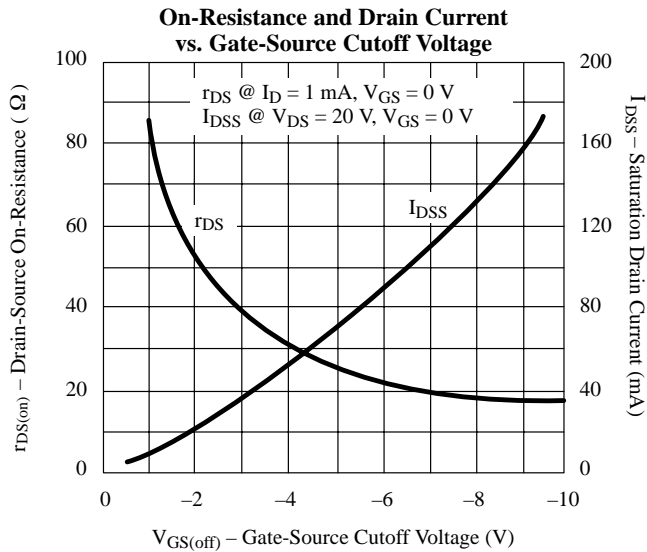

Typical Characteristics (Cont'd)

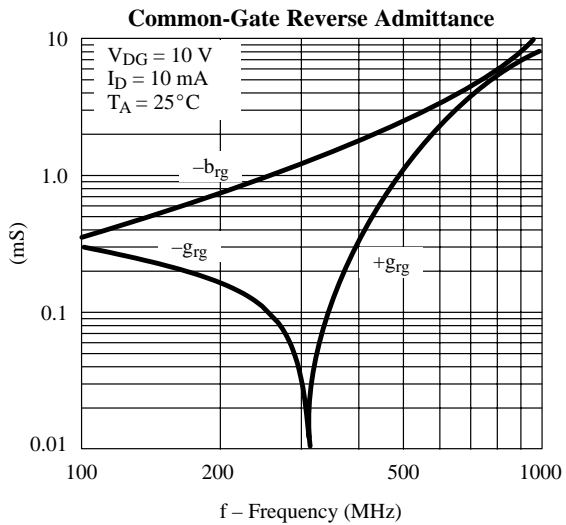
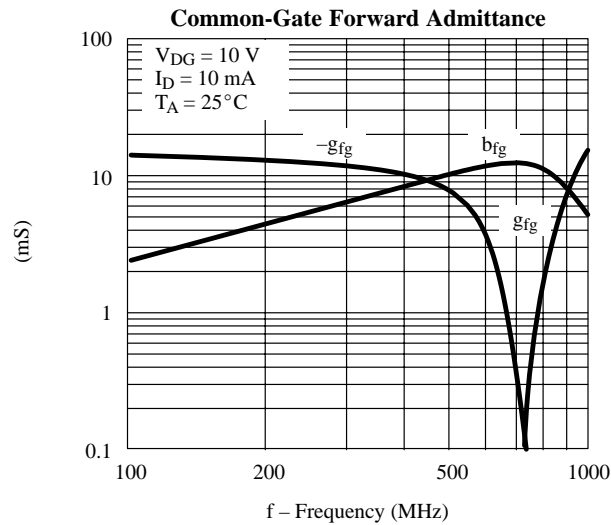
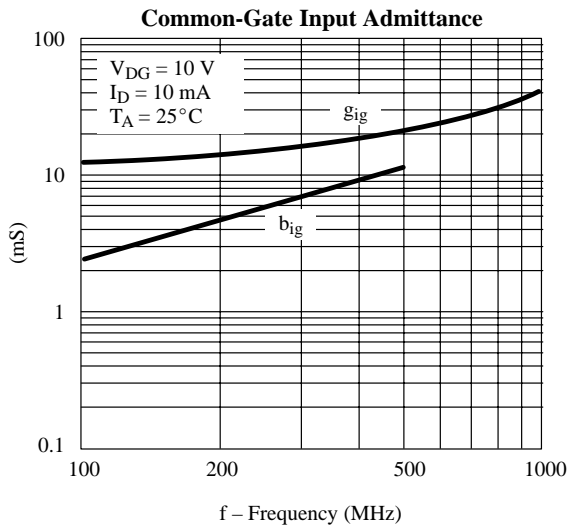
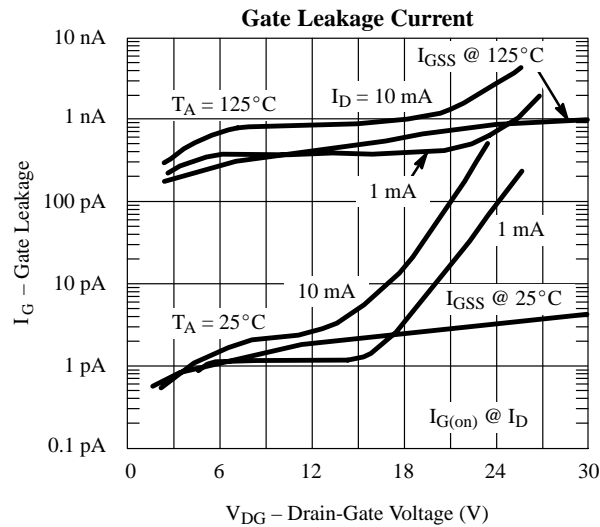
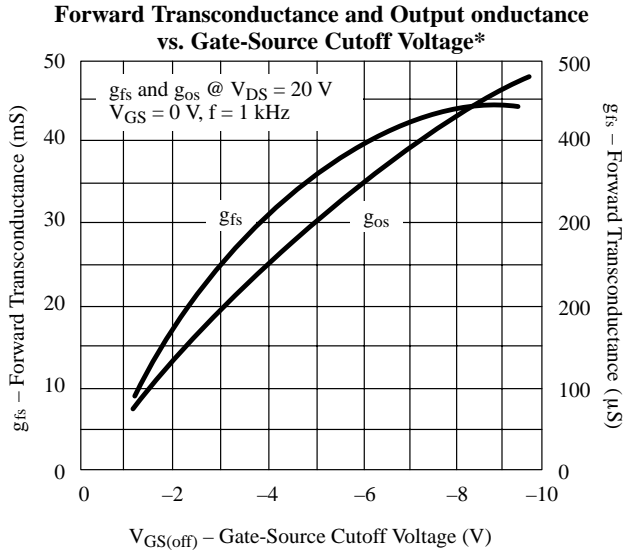
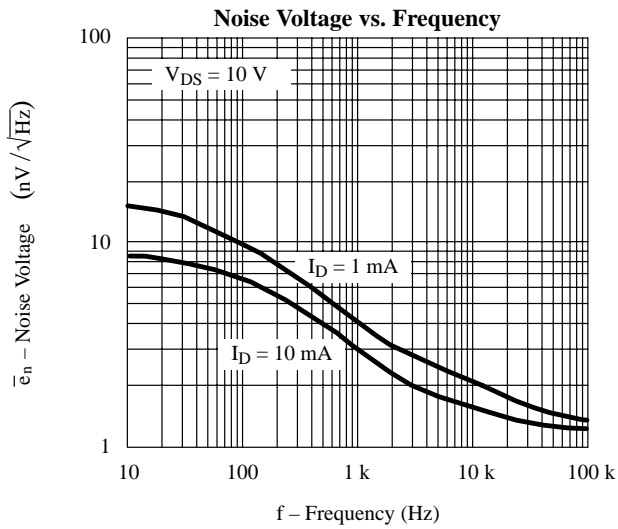

2N/PN/SST4391 Series

Typical Characteristics (Cont'd)

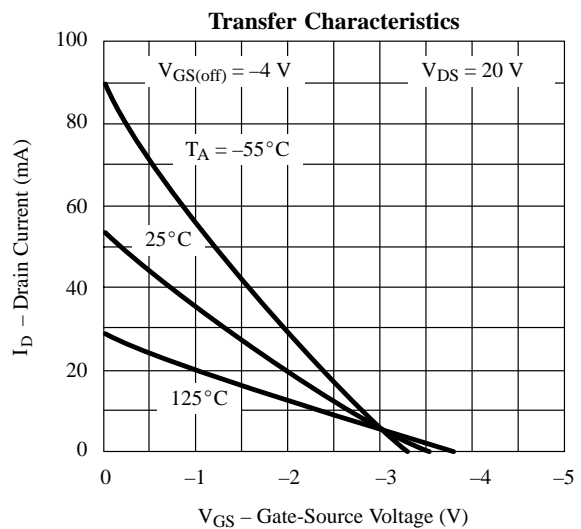
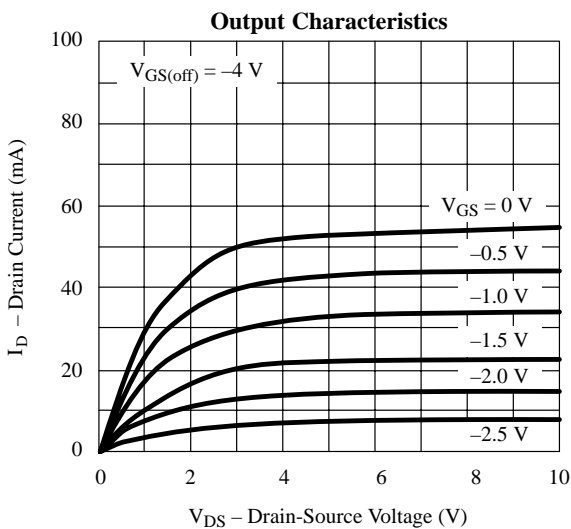
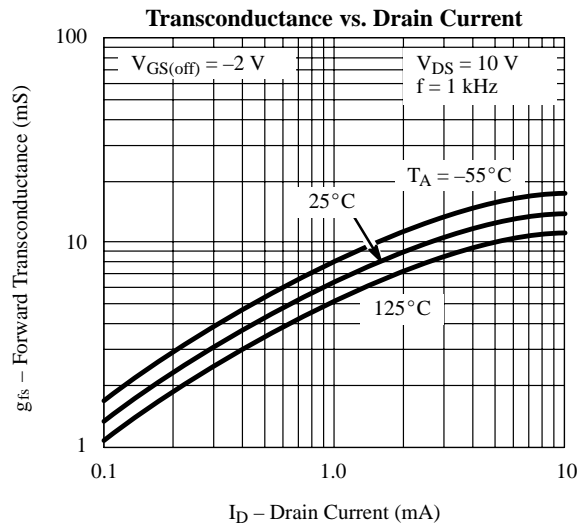
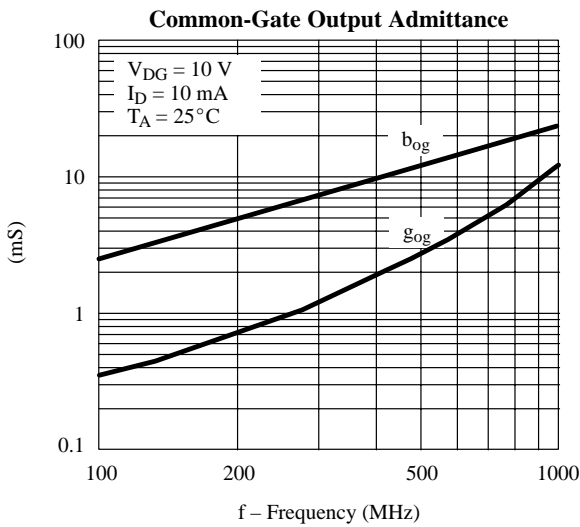

Switching Time Test Circuit

	4391	4392	4393
$V_{GS(L)}$	-12 V	-7 V	-5 V
R_L^*	800 Ω	1600 Ω	3000 Ω
$I_{D(on)}$	12 mA	6 mA	3 mA

*Non-inductive

Input Pulse

Rise Time < 1 ns
Fall Time < 1 ns
Pulse Width 100 ns
PRF 1 MHz

Sampling Scope

Rise Time 0.4 ns
Input Resistance 10 M Ω
Input Capacitance 1.5 pF

See Typical Characteristics curves for changes.

