

Features

- Supports optomechanical mouse
- In M+ mode, compatible with Plug and Play
- Fit a defined Windows 95 class name in M+ mode
- Uses 32.768kHz crystal
- Crystal oscillator circuits on chip
- 1200/9600 baud rate serial output
- Power directly from RS-232C without external power supply
- Three key-switches and four photo-coupler inputs
- Compatible with both M+ and Mouse systems
- Microsoft system mode with middle key supported
- Mouse mode (M+/PC) changeable during power on reset
- RXD with heavy NMOS open drain output

General Description

The HT6513B is specially designed for PnP compatible mouse controller. Capable of driving up to 3 key-switches and 4 photo-couplers (optomechanical mouse) directly into a standard

RS-232C line, and it can be operated without an external power supply. It is compatible with both M+ and Mouse systems with false entries being prevented by internal debounce circuits.

Block Diagram

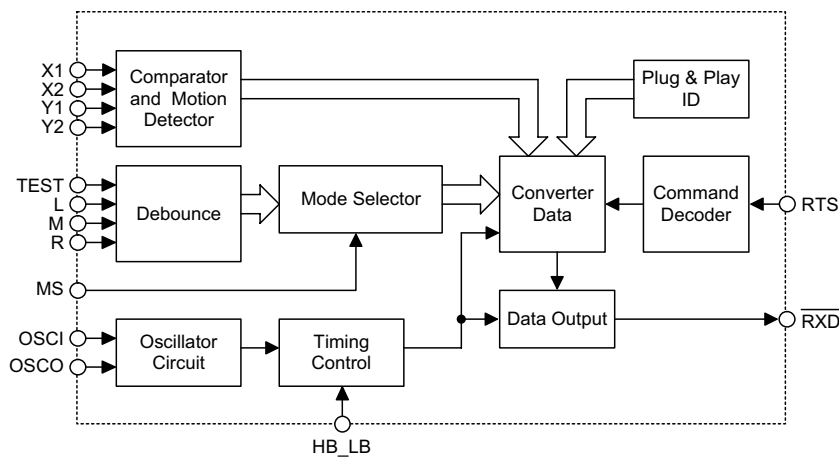

Pin Assignment

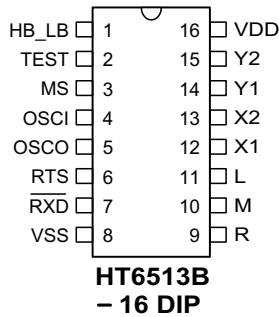

Pad Description

Pad No.	Pad Name	I/O	Description
1	HB_LB	I	If this pin is connected to high level, the $\overline{\text{RXD}}$ can transmit data at 9600 baud rate. The $\overline{\text{RXD}}$ is transmitted at 1200 baud rate while it is connected to low level or floating.
2	TEST	I	For IC test only. The test pin must be connected to V_{SS} , while the chip is under normal usage.
3	MS	I	When this pin is connected to V_{DD} , operation is under M+ mode. If the pin is connected to V_{SS} , then it will operate under the mouse system mode. If MS pin is "floating", the product is under the power-on initiation mode.
4	OSCI	I	Oscillator input pin
5	OSCO	O	Oscillator output pin
6	RTS	I	When a rising edge is sent to RTS the mouse will return a series ID code to identify the mouse mode. The RTS must be kept high while the mouse is in normal operation.
7	$\overline{\text{RXD}}$	O	NMOS, Serial data output
8	VSS	I	Negative power supply
9~11	R M L	I	Three key-switches have seven different combinations. Both key-pressed and key-released signals will be sent accompanied with horizontal and vertical status. The status of the key-switches, the values of horizontal or vertical counter will be present at $\overline{\text{RXD}}$ pin.
12~15	X1 X2 Y1 Y2	I	Four photo-couplers/micro-switch signals denote UP, DOWN, LEFT and RIGHT state. During the scanning period, as long as the photo-couplers/micro-switch change their states, the value of vertical or horizontal counter will increase or decrease accordingly.
16	VDD	I	Positive power supply

Approximate internal connections

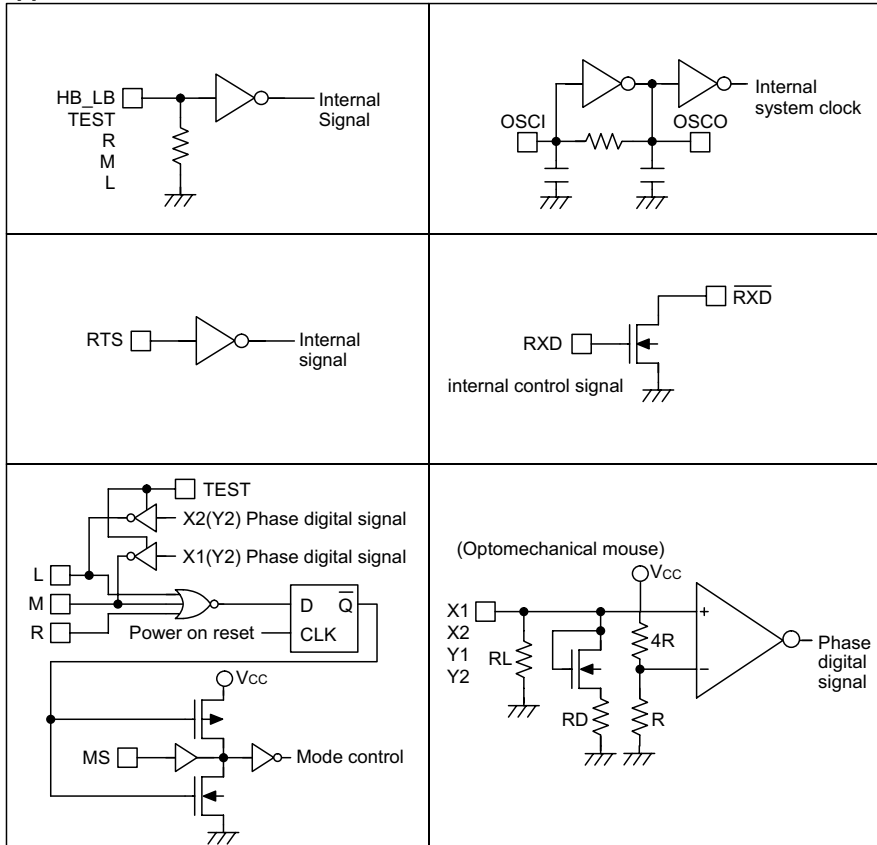

X1/X2/Y1/Y2 Input pin I/V curve (optomechanical mouse)

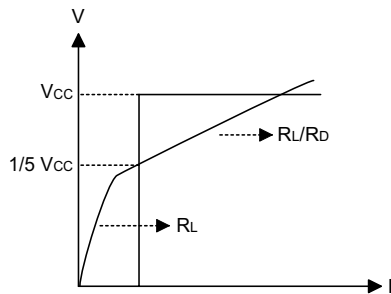

Absolute Maximum Ratings

Supply Voltage-0.3V to 6.5V Storage Temperature.....-50°C to 125°C
 Input Voltage $V_{SS}-0.3V$ to $V_{DD}+0.3V$ Operating Temperature-25°C to 70°C

Note: These are stress ratings only. Stresses exceeding the range specified under "Absolute Maximum Ratings" may cause substantial damage to the device. Functional operation of this device at other conditions beyond those listed in the specification is not implied and prolonged exposure to extreme conditions may affect device reliability.

D.C. Characteristics
 $T_a=25^\circ\text{C}$

Symbol	Parameter	Test Conditions		Min.	Typ.	Max.	Unit
		V_{DD}	Conditions				
V_{DD}	Operating Voltage	—	—	3.5	—	6	V
I_{DD}	Operating Current	5.6V	No load	—	400	600	μA
V_{IL}	X1, X2, Y1, Y2 Input Low Voltage	5.6V	—	0	—	1.0	V
V_{IH}	X1, X2, Y1, Y2 Input High Voltage	5.6V	—	1.4	—	5.6	V
V_{IL1}	Input Low Voltage, Other Pin	5.6V	—	0	—	1	V
V_{IH1}	Input High Voltage, Other Pin	5.6V	—	3.5	—	5.6	V
I_{OL1}	$\overline{\text{RXD}}$ Output Sink Current	5.6V	$V_{OL}=0.56\text{V}$	5	10	—	mA
V_{OH}	$\overline{\text{RXD}}$ High-level Output Voltage	—	—	—	—	16	V
R_{PL}	Pull-low Resistance	5.6V	L, M, R key-switches	65	—	200	$\text{k}\Omega$
R_L	X1, X2, Y1, Y2 Pull-low Resistance	5.6V	$V_I=0.2\text{V}$	—	60	—	$\text{k}\Omega$

A.C. Characteristics

Ta=25°C

Symbol	Parameter	Test Conditions		Min.	Typ.	Max.	Unit
		V _{DD}	Conditions				
f _{SYS}	System Clock	5.6V	Crystal oscillator	30.8	32.768	34.2	kHz
f _P	Photo-Couple Input Frequency	5.6V	—	—	—	8.2	kHz
f _N	Photo-Couple Operation frequency	5.6V	—	0	—	8	kHz
t _{KD}	Key Debounce	5.6V	—	—	52	—	ms
t _{MS}	Transmission Time	5.6V	Mouse system (1200)	—	41.3	—	ms
		5.6V	Mouse system (9600)	—	5.3	—	ms
t _{MI}	Transmission Time	5.6V	Microsoft (1200)	—	24.8	—	ms
		5.6V	Microsoft (9600)	—	3.18	—	ms
t _{MP}	Transmission Time	5.6V	Microsoft + (1200)	—	33.1	—	ms
		5.6V	Microsoft + (9600)	—	4.2	—	ms
t _S	Start Bit Time	5.6V	(1200)	—	0.85	—	ms
			(9600)	—	0.106	—	ms
t _D	Data Bit Time	5.6V	(1200)	—	0.82	—	ms
			(9600)	—	0.106	—	ms
t _P	Stop Bit Time	5.6V	(1200)	—	0.82	—	ms
			(9600)	—	0.106	—	ms
t _{RD}	Mode Code Delay Time (f _{SYS} =32.768kHz)	5.6V	(1200)	15	—	14	ms
			(9600)	1.9	—	1.7	ms
t _r	Rising Edge Crossed Width	5.6V	—	31	—	—	μs
t _f	Falling Edge Crossed Width	5.6V	—	31	—	—	μs

Functional Description

Mouse system mode

Any change of state of the mouse key-switches or photo-couplers will be detected by the chip and transmitted over the RS-232C. The mouse system protocol will send five words at a 1200/9600 baud rate with each word containing 10 bits, 1 start bit, 1 stop bit and 8 data bits.

The first, second and third words correspond to key switch-status, horizontal counter and vertical counter respectively. The auto-speed sensing circuits ensure detection of higher mouse speeds resulting in the use of the 4th and 5th words for extra horizontal and vertical overflow counts respectively. For lower mouse speeds the 4th and 5th words remain at zero.

Output word format

Bit No.	Mouse system word structures							
	7	6	5	4	3	2	1	0
1st word	1	0	0	0	0	L'	M'	R'
2nd word	H7	H6	H5	H4	H3	H2	H1	H0
3rd word	V7	V6	V5	V4	V3	V2	V1	V0
4th word	EH7	EH6	EH5	EH4	EH3	EH2	EH1	EH0
5th word	EV7	EV6	EV5	EV4	EV3	EV2	EV1	EV0

' : denotes complement value

H0~H7: Horizontal counter value

V0~V7: Vertical counter value

EH0~EH7: Extra horizontal counter value

EV0~EV7: Extra vertical counter value

Microsoft plus (M+) mode

Three words are transmitted with each word divided into 1 start bit, 7 data bits and 2 stop bits. The "L" and "R" switch status together with the two most significant bits of both vertical and horizontal counters are transferred in this first word. The second and third word represent the horizontal and vertical counters respectively. Note that this vertical data is recorded in 2's complement format.

When the "M" Switch is pressed or released it will trigger the fourth word active.

Output word format

Bit No.	Microsoft M+ word structures						
	6	5	4	3	2	1	0
1st word	1	L	R	V7'	V6'	H7	H6
2nd word	0	H5	H4	H3	H2	H1	H0
3rd word	0	V5'	V4'	V3'	V2'	V1'	V0'
4th word	0	M	0	0	0	0	0

Win 95 PnP ID fields

For compatibility with old serial mouse drivers, all mouse-compatible pointing devices must restrict themselves to a 6 bit character set, for all fields except the mouse ID. Therefore, all

old-mouse-compatible strings are limited to values of 0x00 to 0x3f, character strings are ASCIIcodes from 0x20 to 0x5f, offset by subtracting 0x20.

M+ mode

Field Name	Size	Field Data	Description
Old Mouse ID	1	4D, 33	Identifies a mouse for old microsoft mode drivers
Begin Pnp	1	08	"(" indicates PnP IDs will follow
Pnp Rev	2	01, 24	Identifies PnP version 1.0
EISA ID	3	28, 34, 2B	"HTK" (A mouse company)
Product ID	4	10, 10, 10, 11	"0001" (Unique product identifier)
Extended	1	3C	"\"
Class Name	6	3C, 2D,2F, 35, 33, 25	"\MOUSE" fits a defined Windows 95 class name
Driver ID	8	3C, 30, 2E, 30, 10, 26,10, 23	"\PNP0F0C" fits a defined Windows 95 microsoft mouse compatible ID
Check sum	2	19, 12	Check all characters from Begin PnP to End PnP, exclusive of the checksum characters themselves.
End PnP	1	09	")" indicates PnP IDs complete

Mouse system mode

6D

Timing Diagrams

Word structure :

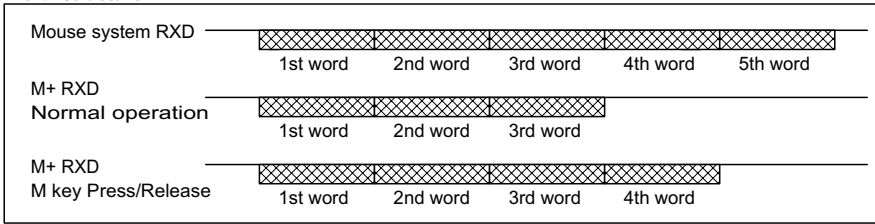

Key output :

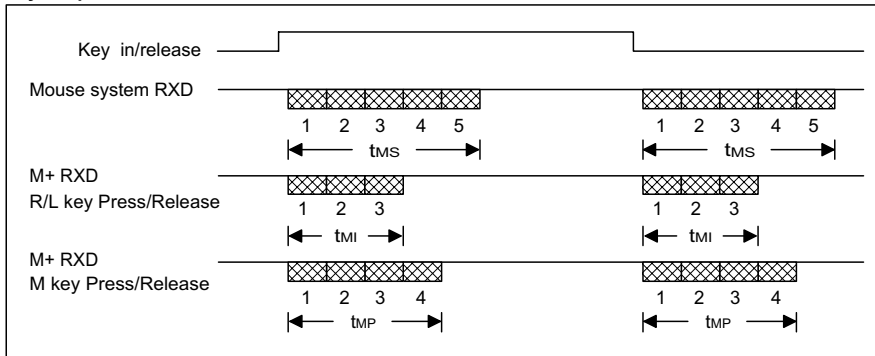

Bit Structure :

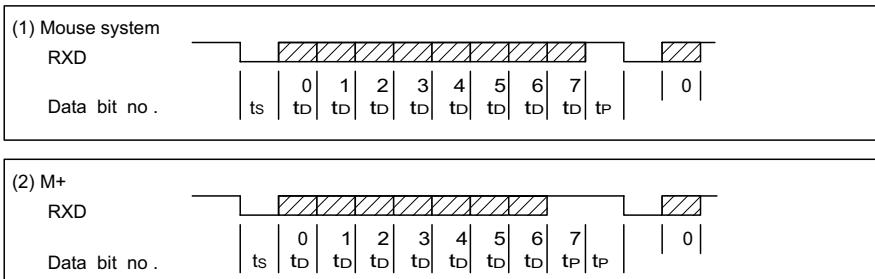

Note: RXD is complement of \overline{RXD} .

Mode selection timing

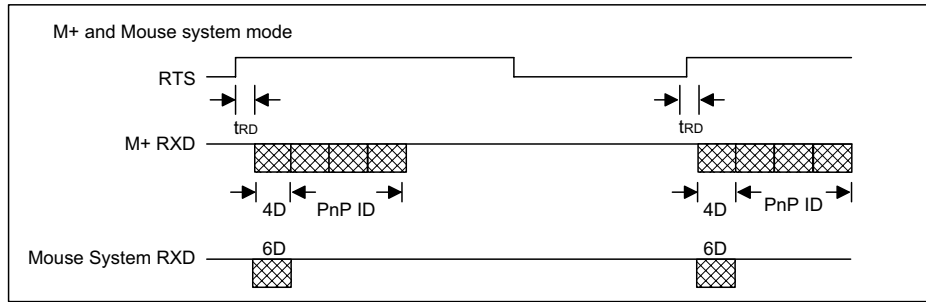

PnP COM Enumerator timing

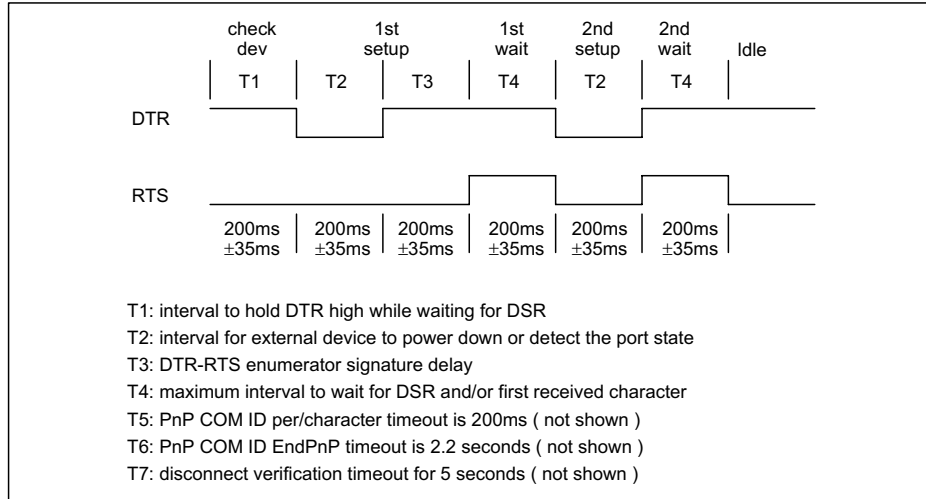
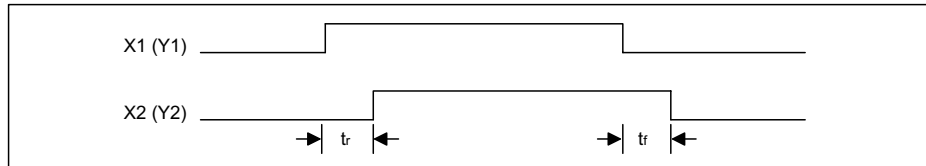
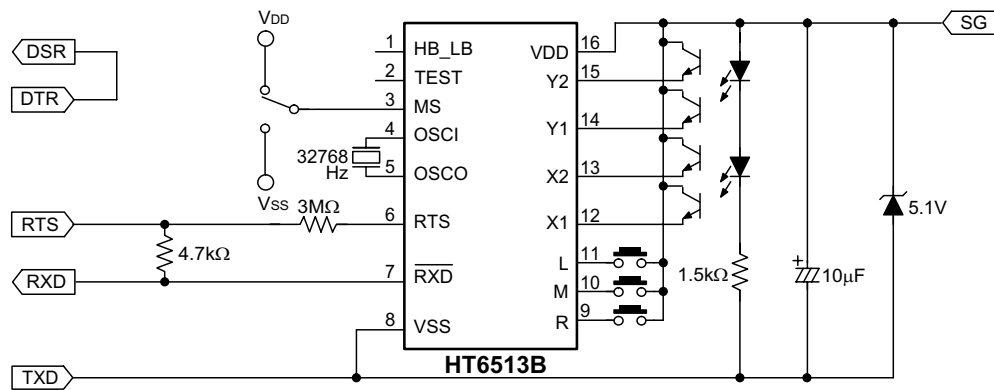

Photo-coupler crossed width



Application Circuits



Holtek Semiconductor Inc. (Headquarters)

No.3 Creation Rd. II, Science-based Industrial Park, Hsinchu, Taiwan, R.O.C.
Tel: 886-3-563-1999
Fax: 886-3-563-1189

Holtek Semiconductor Inc. (Taipei Office)

5F, No.576, Sec.7 Chung Hsiao E. Rd., Taipei, Taiwan, R.O.C.
Tel: 886-2-2782-9635
Fax: 886-2-2782-9636
Fax: 886-2-2782-7128 (International sales hotline)

Holtek Semiconductor (Hong Kong) Ltd.

RM.711, Tower 2, Cheung Sha Wan Plaza, 833 Cheung Sha Wan Rd., Kowloon, Hong Kong
Tel: 852-2-745-8288
Fax: 852-2-742-8657

Copyright © 2000 by HOLTEK SEMICONDUCTOR INC.

The information appearing in this Data Sheet is believed to be accurate at the time of publication. However, Holtek assumes no responsibility arising from the use of the specifications described. The applications mentioned herein are used solely for the purpose of illustration and Holtek makes no warranty or representation that such applications will be suitable without further modification, nor recommends the use of its products for application that may present a risk to human life due to malfunction or otherwise. Holtek reserves the right to alter its products without prior notification. For the most up-to-date information, please visit our web site at <http://www.holtek.com.tw>.