

Synchronous PWM Controller

■ Features

- Single or Dual Supply Application
- $0.8V \pm 1.0\%$ Voltage Reference.
- Fast transient response.
- Synchronous operation for high efficiency (95%)
- On-chip power good, OVP protect.
- Small size with minimum external components
- Soft Start and enable functions
- Industrial temperature range
- Under Voltage Lockout function
- SOP-14L package

■ Applications

- Microprocessor core supply
- Low cost synchronous applications
- Voltage Regulator Modules (VRM)
- DDR termination supplies
- Networking power supplies
- Sequenced power supplies

■ Pin Assignment

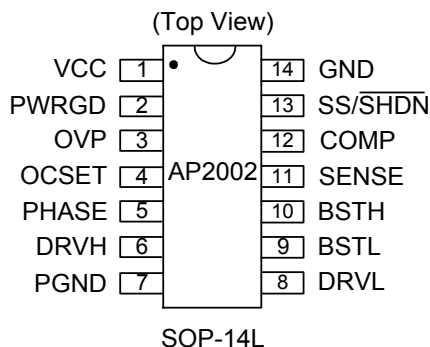

■ Ordering Information

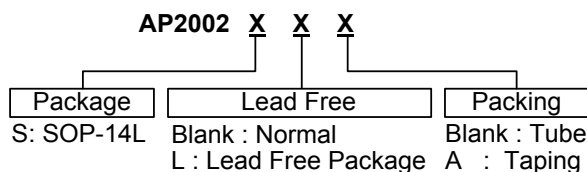

■ General Description

The AP2002 is a low-cost, full featured, and synchronous voltage-mode controller designed for use in single ended power supply applications where efficiency is of primary concern. This synchronous operation allows the elimination of heat sinks in many applications. The AP2002 is ideal for implementing DC/DC converters that is needed for the power advanced microprocessors in low cost systems, or in distributed power applications where efficiency is important. Internal level-shift, high-side drive circuitry, and preset shoot-thru control, allows the use of inexpensive N-channel power switches.

AP2002 features include temperature compensated voltage reference, an internal 200Khz virtual frequency oscillator, under voltage lockout protection, soft-start function and current sense comparator circuitry. Power good signaling, shutdown, and over voltage protection are also provided by AP2002.

■ Pin Descriptions

Name	Description
VCC	Chip supply voltage
PWRGD	Logic high indicates correct output voltage (open drain output)
OVP	Over voltage protection
OCSET	Sets the converter over-current trip point
PHASE	Input from the phase node between the MOSFETs
DRVH	High side driver output
PGND	Power ground
DRVL	Low side driver output
BSTL	Bootstrap, low side driver
BSTH	Bootstrap, high side driver
SENSE	Voltage sense input
COMP	Compensation pin
SS/SHDN	Soft start, a capacitor to ground sets the slow start time
GND	Signal ground

■ Block Diagram

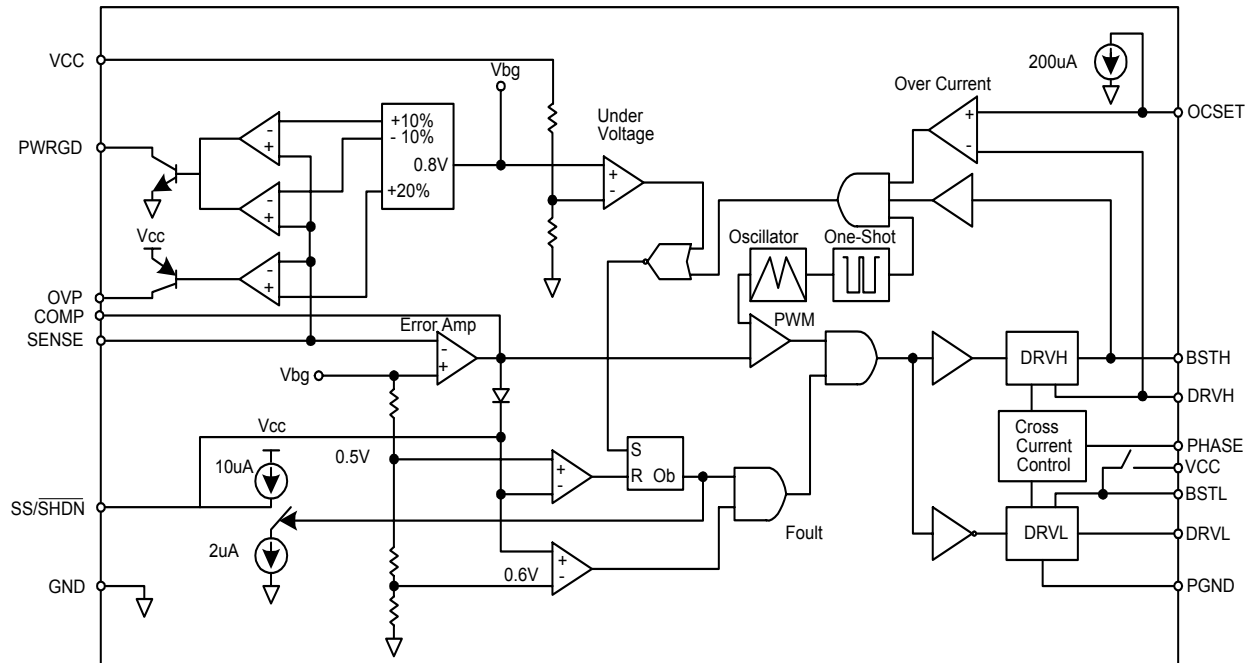

■ Absolute Maximum Ratings

Symbol	Parameter	Max.	Unit
V_{IN}	VCC, BSTL to GND	-1 to 14	V
V_{PHASE}	PGND to GND	± 0.5	V
	PHASE to GND	-1 to 18	V
	BSTH to PHASE	14	V
θ_{JC}	Thermal Resistance Junction to Case	45	$^{\circ}C/W$
θ_{JA}	Thermal Resistance Junction to Ambient	115	$^{\circ}C/W$
T_{OP}	Operating Temperature Range	-40 to +85	$^{\circ}C$
T_{ST}	Storage Temperature Range	-65 to +150	$^{\circ}C$
T_{LEAD}	Lead Temperature (Soldering) 10 Sec.	300	$^{\circ}C$



■ Electrical Characteristics

Unless specified: $V_{CC} = 4.75V$ to $12.6V$; $GND = PGND = 0V$; $FB = V_O$; $V_{BSTL} = 12V$; $V_{BSTH-PHASE} = 12V$; $T_J = 25^\circ C$

Symbol	Parameter	Conditions	Min.	Typ.	Max.	Unit
--------	-----------	------------	------	------	------	------

Power Supply

V_{CC}	Supply Voltage	V_{CC}	4.2		12.6	V
I_{CC}	Supply Current			6	10	mA
ΔV_{LINE}	Line Regulation	$VO = 2.5V$		0.5		%

Error Amplifier

A_{OL}	Gain (A_{OL})			50		dB
I_B	Input Bias			5	8	μA

Oscillator

F_{OSC}	Oscillator Frequency		180	200	220	KHz
DC_{MAX}	Oscillator Max Duty Cycle		90	95		%

MOSFET Drivers

I_{DRVH}	DRVH Source/Sink	$V_{BSTH} - V_{DRVH} = 4.5V$ $V_{DRVH} - V_{PHASE} = 2V$	1			A
I_{DRVL}	DRVL Source/Sink	$V_{BSTH} - V_{DRVL} = 4.5V$ $V_{DRVL} - V_{PGND} = 2V$	1			A

Protection

D_{TH}	OVP Threshold			20		%
I_{OVP}	OVP Source Current	$V_{OVP} = 3V$	10			mA
D_{PG}	Power Good Threshold		88		112	%
T_{DEAD}	Dead Time		45		100	nS
I_{OCSET}	Over Current Set Isink	$2.0V \leq V_{OCSET} \leq 12V$	180	200	220	μA

Reference

V_{REF}	Reference Voltage	$0^\circ C$ to $70^\circ C$	0.792	0.8	0.808	V
	Accuracy		-1		+1	%

Soft Start

I_{SSC}	Charge Current	$V_{SS} = 1.5V$	8.0	10	12	μA
I_{SSD}	Discharge Current	$V_{SS} = 1.5V$	1.3	2	2.7	μA

Under voltage lockout (UVLO)

V_{UT}	Upper threshold voltage (V_{CC})	$I_{O(REF)} = 0.1mA$ $T_A = 25^\circ C$		4.2	4.4	V
V_{LWT}	Lower threshold voltage (V_{CC})			4.0		V
V_{HT}	Hysteresis (V_{CC})			200		mV

Note 1. Specification refers to Typical Application Circuit.

Note 2. This device is ESD sensitive. Use of standard ESD handling precautions is required.

■ Typical Application Circuit

(1)

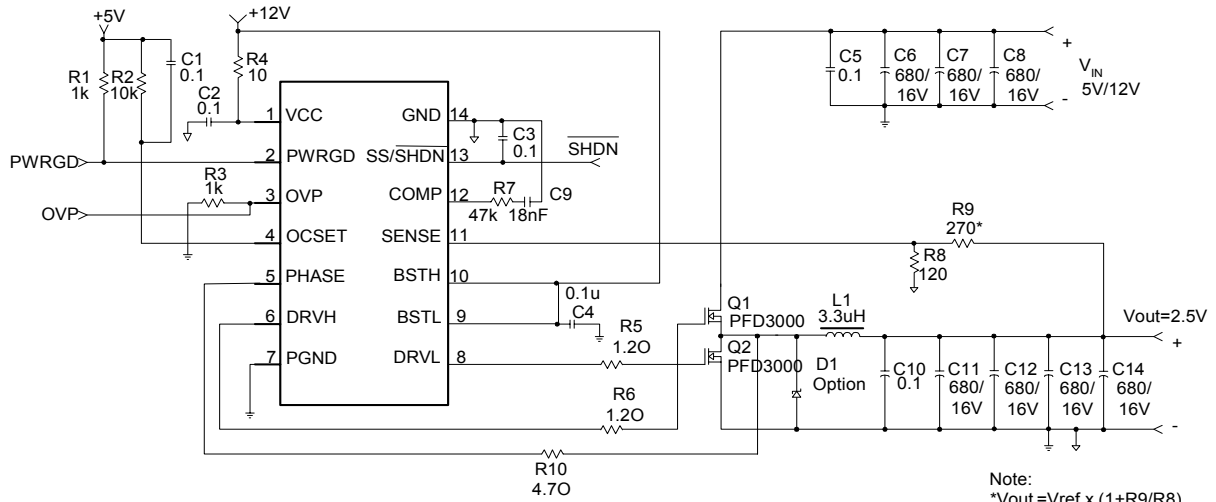

5V & 12V dual input circuit

(2)

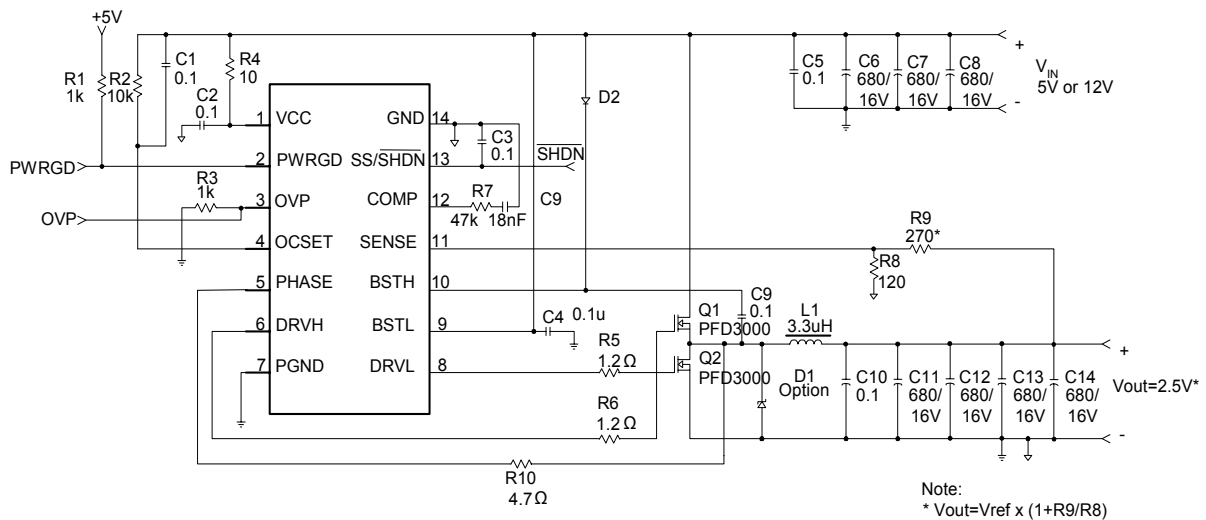

5V or 12V input with Bootstrapped BSTH

Synchronous PWM Controller

■ Function Description

Synchronous Buck Converter

Primary V_{CORE} power is provided by a synchronous, voltage-mode pulse width modulated (PWM) controller. This section has all the features required to build a high efficiency synchronous buck converter, including “Power Good” flag, shutdown, and cycle-by-cycle current limit.

The output voltage of the synchronous converter is set and controlled by the output of the error amplifier. The external resistive divider reference voltage is derived from an internal trimmed band-gap voltage reference. The inverting input of the error amplifier receives its voltage from the SENSE pin.

The internal oscillator uses an on-chip capacitor and trimmed precision current sources to set the oscillation frequency to 200KHz. The triangular output of the oscillator sets the reference voltage at the inverting input of the comparator. When the oscillator output voltage drops below the error amplifier output voltage, the comparator output goes high. This pulls DRV_L low, turning off the low-side FET, and DRV_H is pulled high, turning on the high-side FET (once the cross-current control allows it). When the oscillator voltage rises back above the error amplifier output voltage, the comparator output goes low. This pulls DRV_H low, turning off the high-side FET, and DRV_L is pulled high, turning on the low-side FET (once the cross-current control allows it).

As SENSE increases, the output voltage of the error amplifier decreases. This causes a reduction in the on-time of the high-side MOSFET connected to DRV_H, hence lowering the output voltage.

Under Voltage Lockout

The under voltage lockout circuit of the AP2002 assures that the high-side MOSFET driver outputs remain in the off state whenever the supply voltage drops below set parameters. Lockout occurs if V_{CC} falls below 4.1V. Normal operation resumes once V_{CC} rises above 4.2V.

Over-Voltage Protection

The over-voltage protection pin (OVP) is high only when the voltage at SENSE is 20% higher than the target value programmed by the external resistor divider. The OVP pin is internally connected to a PNP's collector.

Power Good

The power good function is to confirm that the regulator outputs are within +/- 10% of the programmed level. PWRGD remains high as long as this condition is met. PWRGD is connected to an internal open collector NPN transistor.

Soft Start

Initially, SS/SHDN sources 10uA of current to charge an external capacitor. The outputs of the error amplifiers are clamped to a voltage proportional to the voltage on SS/SHDN. This limits the on-time of the high-side MOSFET, thus leading to a controlled ramp-up of the output voltages.

$R_{DS(ON)}$ Current Limiting

The current limit threshold is setting by connecting an external resistor from V_{CC} supply to OCSET. The voltage drop across this resistor is due to the 200uA internal sink sets the voltage at the pin. This voltage is compared to the voltage at the PHASE node. This comparison is made only when the high-side drive is high to avoid false current limit triggering due to un-contributing measurements from the MOSFETs off-voltage. When the voltage at PHASE is less than the voltage at OCSET, an over-current condition occurs and the soft start cycle is initiated. The synchronous switch turns off and SS/SHDN starts to sink 2uA. When SS/SHDN reaches 0.8V, it then starts to source 10uA and a new cycle begins.

Synchronous PWM Controller

■ Function Description (Continued)

Hiccup Mode

During power up, the SS/ $\overline{\text{SHDN}}$ pin is internally pulled low until V_{CC} reaches the under-voltage lockout level of 4.2V. Once V_{CC} has reached 4.2V, the SS/ $\overline{\text{SHDN}}$ pin is released and begins to source 10uA of current to the external soft-start capacitor. As the soft-start voltage rises, the output of the internal error amplifier is clamped to this voltage. When the error signal reaches the level of the internal triangular oscillator, which swings from 1V to 2V at a fixed frequency of 200KHz, switching occurs. As the error signal crosses over the oscillator signal, the duty cycle of the PWM signal continues to increase until the output comes into regulation. If an over-current condition has not occurred the soft-start voltage will continue to rise and level off at about 2.2V.

An over-current condition occurs when the high-side drive is turned on, but the PHASE node does not reach the voltage level set at the OCSET pin. The PHASE node is sampled only once per cycle during the valley of the triangular oscillator. Once an over-current occurs, the high-side drive is turned off and the low-side drive turns on and the SS/ $\overline{\text{SHDN}}$ pin begins to sink 2uA. The soft-start

voltage will begin to decrease as the 2uA of current discharge the external capacitor. When the soft-start voltage reaches 0.8V, the SS/ $\overline{\text{SHDN}}$ pin will begin to source 10uA and begin to charge the external capacitor causing the soft-start voltage to rise again. Again, when the soft-start voltage reaches the level of the internal oscillator, switching will occur.

If the over-current condition is no longer present, normal operation will continue. If the over-current condition is still present, the SS/ $\overline{\text{SHDN}}$ pin will again begin to sink 2uA. This cycle will continue indefinitely until the over-current condition is removed.

In conclusion, above is shown a typical "12V Application Circuit" which has a BSTH voltage derived by bootstrapping input voltage to the PHASE node through diode D1. This circuit is very useful in cases where only input power of 5V(or 12V) is available.

In order to prevent substrate glitching, a small-signal diode should be placed in close proximity to the chip with cathode connected to PHASE and anode connected to PGND.

■ Marking Information

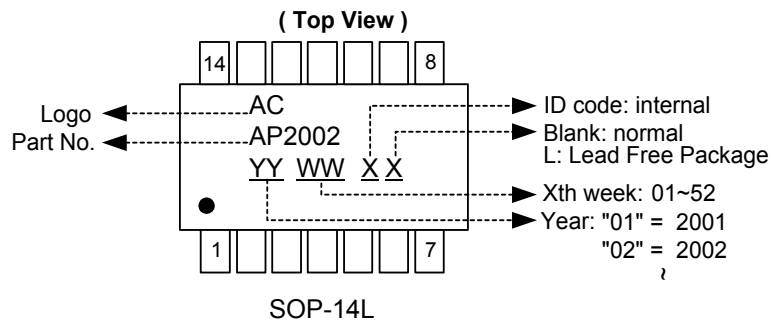

■ Package Information

(1) Package Type: SOP-14L

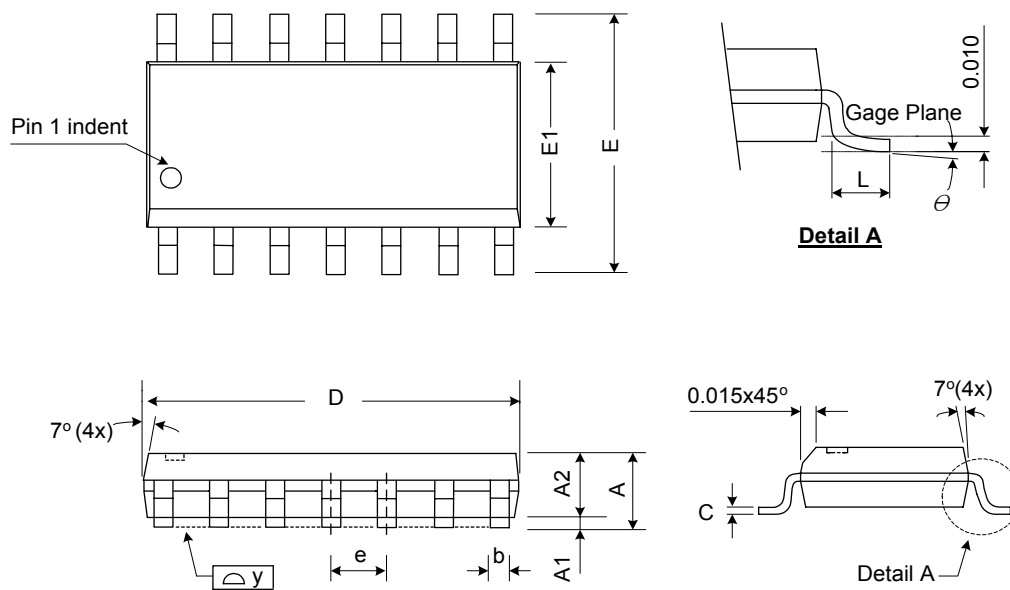

Symbol	Dimensions In Millimeters			Dimensions In Inches		
	Min.	Nom.	Max.	Min.	Nom.	Max.
A	1.47	1.60	1.730	0.0580	0.063	0.0680
A1	0.10	-	0.250	0.0040	-	0.0100
A2	-	1.45	-	-	0.057	-
b	0.33	0.41	0.510	0.0130	0.016	0.0200
C	0.19	0.20	0.250	0.0075	0.008	0.0098
D	8.53	8.64	8.740	0.3360	0.340	0.3440
E	5.80	6.00	6.200	0.2283	0.236	0.2441
E1	3.80	3.90	3.990	0.1496	0.153	0.1571
e	-	1.27	-	-	0.050	-
L	0.38	0.71	1.270	0.0150	0.028	0.0500
Y	-	-	0.076	-	-	0.0030
θ	0°	-	8°	0°	-	8°