

## ***HIGH-CURRENT HALF-BRIDGE PRINthead/MOTOR DRIVER—WITH INTERNAL CURRENT SENSING AND CONTROL***

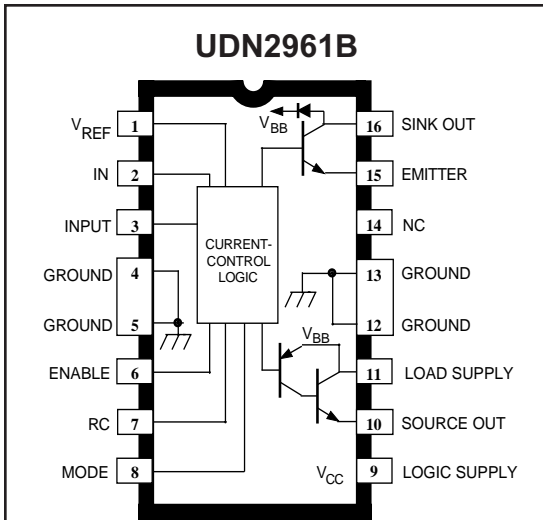

Dwg. PP-035

### **ABSOLUTE MAXIMUM RATINGS**

Supply Voltage, $V_{BB}$ .....	<b>45 V</b>
Output Current, $I_{OUT}$ (continuous) .	<b><math>\pm 3.4</math> A</b>
( $t_w \leq 20 \mu s$ , 10% duty cycle) ..	<b><math>\pm 4.0</math> A</b>
Logic Supply Voltage, $V_{CC}$ .....	<b>7.0 V</b>
Input Voltage Range,	
$V_{IN}$ .....	<b>-0.3 V to +7.0 V</b>
Package Power Dissipation,	
$P_D$ .....	<b>See Graph</b>
Operating Temperature Range,	
$T_A$ .....	<b>-20°C to +85°C</b>
Junction Temperature, $T_J$ .....	<b>+150°C*</b>
Storage Temperature Range,	
$T_S$ .....	<b>-55°C to +150°C</b>

Output current rating may be restricted to a value determined by system concerns and factors. These include: system duty cycle and timing, ambient temperature, and use of any heatsinking and/or forced cooling. For reliable operation, the specified maximum junction temperature should not be exceeded.

\* Fault conditions that produce excessive junction temperature will activate device thermal shutdown circuitry. These conditions can be tolerated, but should be avoided.

The UDN2961B and UDN2961W are 3.4 A half bridges designed specifically for driving solenoid printheads, stepper motors, and dc motors. The UDN2961B/W consists of a power source driver output, a power sink driver output, a flyback recovery diode, internal current sensing circuitry, and a user-selectable fixed off-time chopper circuit.

The output drivers are capable of sustaining 45 V with continuous currents of  $\pm 3.4$  A and peak transient currents of  $\pm 4$  A permitted. The outputs have been optimized for a low output saturation voltage (typically 2.6 V total source plus sink drops at 3.4 A).

For output current control, load current is sensed internally and limited by chopping the output driver(s) in a user-selectable fixed off-time PWM mode. The maximum output current is determined by the user's selection of a reference voltage. The MODE pin determines whether the current control circuitry will chop in a slow current-decay mode (only the source driver switching) or in a fast current-decay mode (source and sink switching). A user-selectable blanking window prevents false triggering of the current control circuitry during chopping.

The UDN2961B is supplied in a 16-pin dual in-line plastic batwing package with a copper lead-frame and heat sinkable tabs for improved power dissipation capabilities. For higher power dissipation requirements, the UDN2961W is supplied in a 12-pin single in-line power tab package.

### **FEATURES**

- 3.4 A, 45 V Source and Sink Drivers
- Internal Current Sensing
- User-Selectable Fixed Off-Time PWM Current Control
- Internal Flyback Diode
- Low Output Saturation Voltage
- Chip Enable
- Fast or Slow Current-Decay Modes
- Programmable Blanking Window
- Internal Thermal Shutdown Circuitry

Always order by complete part number:

Part Number	Package
UDN2961B	16-Pin DIP
UDN2961W	12-Pin Power-Tab SIP

# 2961 HIGH-CURRENT HALF-BRIDGE PRINthead/MOTOR DRIVER

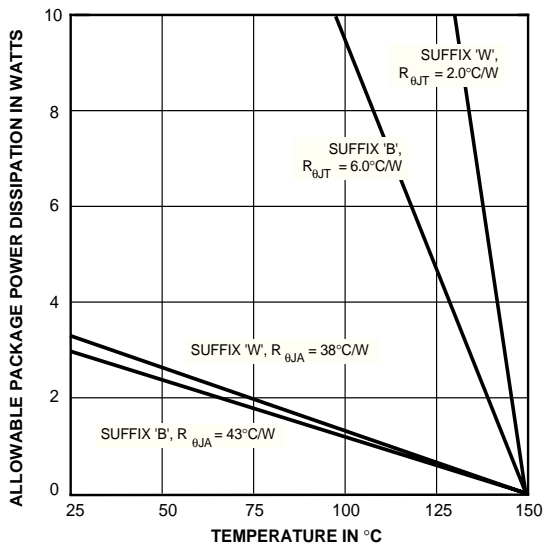

Dwg. GP-032A

## FUNCTIONAL BLOCK DIAGRAM

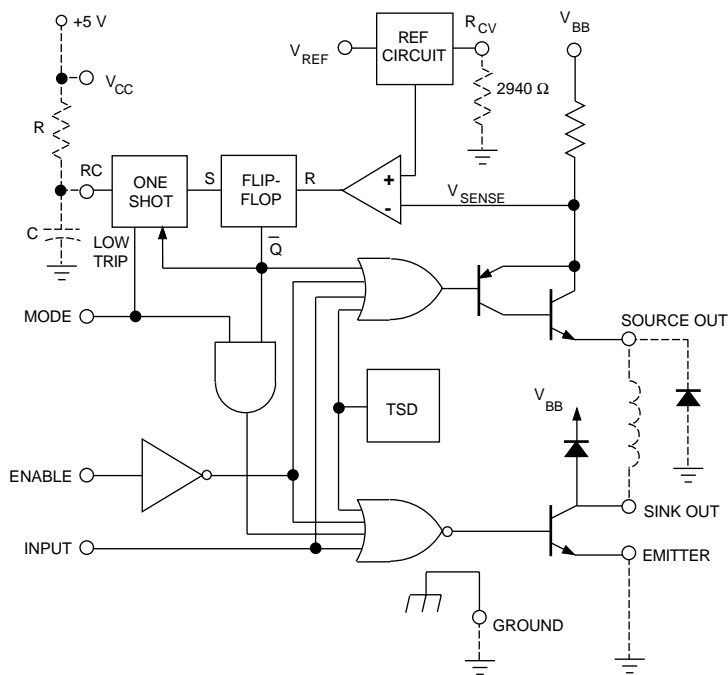

Dwg. FP-019A

## UDN2961W

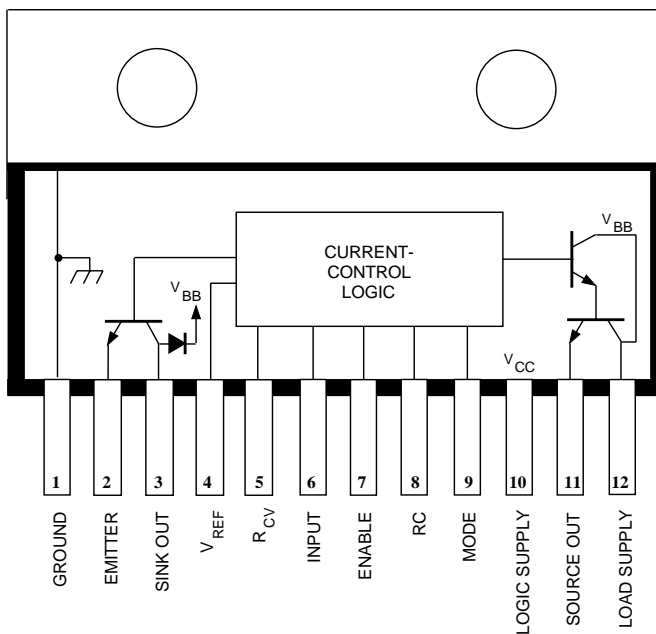

Dwg. PP-036

# 2961 HIGH-CURRENT HALF-BRIDGE PRINthead/MOTOR DRIVER

**ELECTRICAL CHARACTERISTICS** at  $T_A = +25^\circ\text{C}$ ,  $V_{BB} = 45\text{ V}$ ,  
 $V_{CC} = 4.75\text{ V to } 5.25\text{ V}$ ,  $R_{CV} = 2940\ \Omega$  (unless otherwise noted).

Characteristic	Symbol	Test Conditions	Limits			
			Min.	Typ.	Max.	Units

## Output Drivers

Output Leakage Current	$I_{CEX}$	$V_{EN} = 0.8\text{ V}$ , $V_{SOURCE} = 0\text{ V}$	—	<-1.0	-100	$\mu\text{A}$
		$V_{EN} = 0.8\text{ V}$ , $V_{SINK} = 45\text{ V}$	—	<1.0	100	$\mu\text{A}$
Output Saturation Voltage	$V_{CE(SAT)}$	Source Driver, $I_{OUT} = -3.4\text{ A}$	—	1.6	2.2	V
		Source Driver, $I_{OUT} = -3.0\text{ A}$	—	1.5	—	V
		Sink Driver, $I_{OUT} = 3.4\text{ A}$	—	1.0	1.4	V
		Sink Driver, $I_{OUT} = 3.0\text{ A}$	—	0.9	—	V
Output Sustaining Voltage	$V_{CE(sus)}$	$I_{OUT} = \pm 3.4\text{ A}$ , $L = 3\text{ mH}$	45	—	—	V
Recovery Diode Leakage Current	$I_R$	$V_R = 45\text{ V}$	—	<1.0	100	$\mu\text{A}$
Recovery Diode Forward Voltage	$V_F$	$I_F = 3.4\text{ A}$	—	—	2.0	V
Motor Supply Current	$I_{BB(on)}$	$V_{EN} = 2.0\text{ V}$ , $V_{IN} = 0.8\text{ V}$ , No Load	—	—	70	mA
	$I_{BB(off)}$	$V_{EN} = 0.8\text{ V}$	—	—	2.5	mA
Output Rise Time	$t_r$	Source Driver, $I_{OUT} = -3.4\text{ A}$	—	—	600	ns
		Sink Driver, $I_{OUT} = 3.4\text{ A}$	—	—	600	ns
Output Fall Time	$t_f$	Source Driver, $I_{OUT} = -3.4\text{ A}$	—	—	600	ns
		Sink Driver, $I_{OUT} = 3.4\text{ A}$	—	—	600	ns

## Control Logic

Logic Input Voltage	$V_{IN(1)}$		2.0	—	—	V
	$V_{IN(0)}$		—	—	0.8	V
Logic Input Current	$I_{IN(1)}$	$V_{IN} = 5.0\text{ V}$	—	—	10	$\mu\text{A}$
	$I_{IN(0)}$	$V_{IN} = 0\text{ V}$	—	—	-1.0	mA
Reference Input Current	$I_{REF}$	$V_{REF} = 5.0\text{ V}$	—	—	50	$\mu\text{A}$
Transconductance	$I_{TRIP}/V_{REF}$	$V_{REF} = 1.0\text{ V}$	0.9	1.0	1.1	A/V
		$V_{REF} = 3.2\text{ V}$	0.9	1.0	1.1	A/V
Logic Supply Current	$I_{CC}$	$V_{EN} = 2.0\text{ V}$ , $V_{IN} = 0.8\text{ V}$ , No Load	—	—	160	mA
		$V_{EN} = 0.8\text{ V}$	—	—	15	mA
Turn On Delay	$t_{pd(on)}$	Source Driver	—	—	600	ns
		Sink Driver	—	—	600	ns
Turn Off Delay	$t_{pd(off)}$	Source Driver	—	—	2.0	$\mu\text{s}$
		Sink Driver	—	—	2.0	$\mu\text{s}$
Thermal Shutdown Temperature	$T_J$		—	165	—	$^\circ\text{C}$

Negative current is defined as coming out of (sourcing) the specified device terminal.

# 2961 HIGH-CURRENT HALF-BRIDGE PRINthead/MOTOR DRIVER

## APPLICATIONS INFORMATION

The UDN2961B/W is a high current half-bridge designed to drive a number of inductive loads such as printer solenoids, stepper motors, and dc motors. Load current is sensed internally and is controlled by pulse-width modulating (PWM) the output driver(s) in a fixed off-time, variable-frequency format. The peak current level is set by the user's selection of a reference voltage. A slow current-decay mode (chopping only the source driver) or a fast current-decay mode (chopping both the source and sink drivers) can be selected via the MODE pin.

### PWM CURRENT CONTROL

A logic low on the MODE pin sets the current-control circuitry into the slow-decay mode. The RS flip-flop is set initially, and both the source driver and the sink driver are turned ON when the INPUT pin is at a logic low. As current in the load increases, it is sensed by the internal sense resistor until the sense voltage equals the trip voltage of the comparator. At this time, the flip-flop is reset and the source driver is turned OFF. Over the range of  $V_{REF} = 0.8\text{ V}$  to  $3.4\text{ V}$ , the output current trip point transfer function is a direct linear function of the reference voltage:

$$I_{TRIP} = V_{REF}$$

To ensure an accurate chop current level ( $\pm 10\%$ ), an external  $2940\ \Omega \pm 1\%$  resistor ( $R_{CV}$ ) is used. The actual load current peak will be slightly higher than the trip point (especially for low-inductance loads) because of the internal logic and switching delays (typically  $1.5\ \mu\text{s}$ ). After the source driver turns OFF, the load current decays, circulating through an external ground clamp diode, the load, and the sink transistor. The source driver's OFF time (and therefore the magnitude of the current decrease) is determined by the one-shot's external RC timing components:

$$t_{OFF} = RC$$

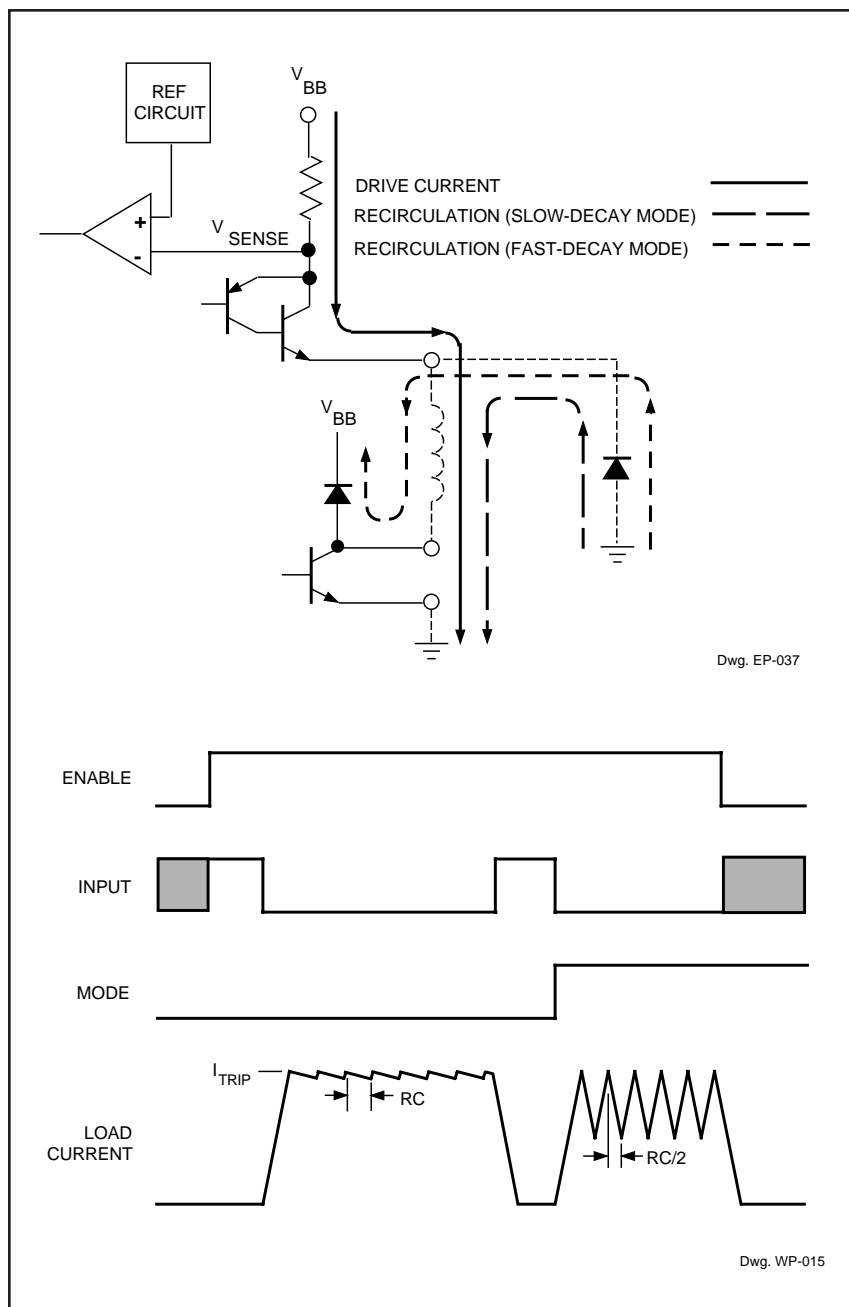

within the range of  $20\text{ k}\Omega$  to  $100\text{ k}\Omega$  and  $100\text{ pF}$  to  $1000\text{ pF}$ . When the one-shot times out, the flip-flop is set again, the source driver is re-enabled, and the load current again is allowed to rise to the set peak value and trip the comparator. This cycle repeats itself, maintaining the average load current at the desired level.

# 2961 HIGH-CURRENT HALF-BRIDGE PRINthead/MOTOR DRIVER

A logic high on the MODE pin sets the current-control circuitry into the fast-decay mode. When the peak current threshold is detected, the flip-flop is reset and both the source driver and the sink driver turn OFF. Load current decays quickly through the external ground clamp diode, the load, and the internal flyback diode. In the fast-decay mode, the OFF time period is one-half the time that is set by the external RC network for the slow-decay mode:

$$t_{\text{OFF}} = \frac{RC}{2}$$

The amount of ripple current, when chopping in the fast-decay mode, is considerably higher than when chopping in the slow-decay mode.

The frequency of the PWM current control is determined by the time required for the load current to reach the set peak threshold (a function of the load characteristics and  $V_{\text{BB}}$ ) plus the OFF time of the switching driver(s) (set by the external RC components).

To prevent false resetting of the flip-flop, due to switching transients and noise, a blanking time for the comparator can be set by the user where  $t_{\text{B}} \approx 3600 \times C$  in the slow-decay mode or  $t_{\text{B}} \approx 2400 \times C$  in the fast-decay mode. For C between 100 pF and 1000 pF,  $t_{\text{B}}$  is in  $\mu\text{s}$ .

## POWER CONSIDERATIONS

The UDN2961B/W outputs are optimized for low power dissipation. The sink driver has a maximum saturation voltage drop of only 1.4 V at 3.4 A, while the source driver has a 2.2 V drop at -3.4 A. Device power dissipation is minimized in the slow-decay mode, as the chopping driver (the source driver) is ON for less than 50% of the chop period. When the source driver is OFF during a chop cycle, power is dissipated on chip only by the sink driver; the rest of the power is dissipated through the external ground clamp diode. In the fast-decay mode, the ON time of the chopping drivers (both the source driver

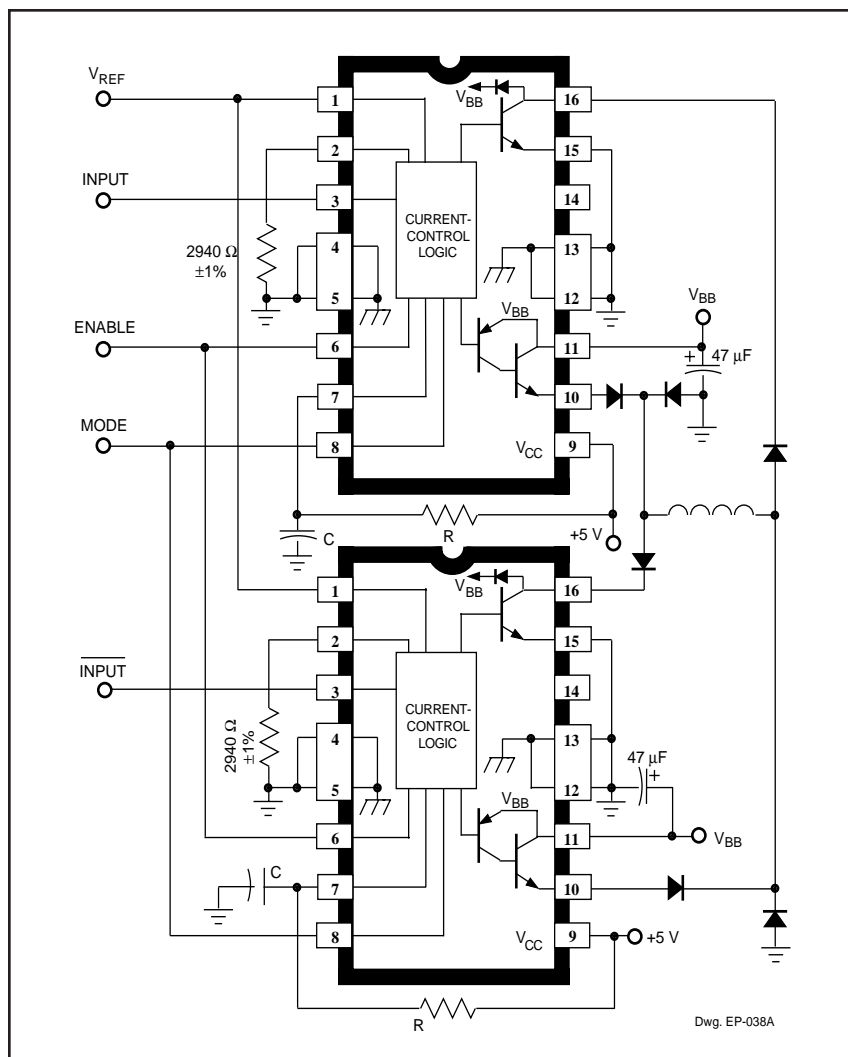

and the sink driver) may be greater than 50%, and the power dissipation will be greater.

## GENERAL

A logic low on the ENABLE pin prevents the source driver and the sink driver from turning ON, regardless of the state of the INPUT pin or the supply voltages. With the ENABLE pin high, a logic low on the INPUT pin turns ON the output drivers.

To protect against inductive load voltage transients, an external ground clamp diode is required. A fast-recovery diode is recommended to reduce power dissipation in the UDN2961B/W. The blanking time prevents false triggering of the current sense comparator, which can be caused by the recovery current spike of the ground clamp diode when the chopping source driver turns ON.

# 2961 HIGH-CURRENT HALF-BRIDGE PRINthead/MOTOR DRIVER

The load supply ( $V_{BB}$ ) should be well decoupled with a capacitor placed as close as possible to the device.

The EMITTER pin should be connected to a high-current power ground.

Thermal shutdown protection circuitry is activated and turns OFF both output drivers at a junction temperature of typically  $+165^{\circ}\text{C}$ . It is intended only to protect the device from catastrophic failures due to excessive junction temperatures and should not imply that output short circuits are permitted. The output drivers are re-enabled when the junction temperature cools down to approximately  $+145^{\circ}\text{C}$ .

## MOTOR DRIVER APPLICATIONS

Two UDN2961B/Ws can be cross connected as shown to form a full-bridge driver circuit. Two full-bridge circuits are needed to drive a two-phase bipolar stepper motor. When in a full-bridge configuration, one INPUT signal must be logically inverted from the other INPUT signal to prevent the simultaneous conduction of a source driver from one half-bridge and the sink driver from the other half-bridge. In order to prevent crossover currents, a turn-ON delay time of  $3\ \mu\text{s}$  is needed between the time an INPUT signal for one of the half bridges goes high and the INPUT signal for the other half bridge goes low.

In addition to the two external ground clamp diodes, diodes in series with the load to the SINK OUT are needed in a full-bridge configuration. These series diodes prevent the sink drivers from conducting on the inverse mode, which can occur when the opposite half-bridge ground clamp diode is conducting and forces the sink driver collector below ground.

If fast current decay is used (MODE = logic high) or pulse width modulation of the load-current direction is used, diodes in series with the load to the SOURCE OUT are needed. These series diodes prevent the SOURCE OUT from inverse conducting during the recirculation period and thereby prevent shoot-through currents from occurring as the drivers turn back ON.



# 2961 HIGH-CURRENT HALF-BRIDGE PRINTHEAD/MOTOR DRIVER

## UDN2961B Dimensions in Inches (controlling dimensions)

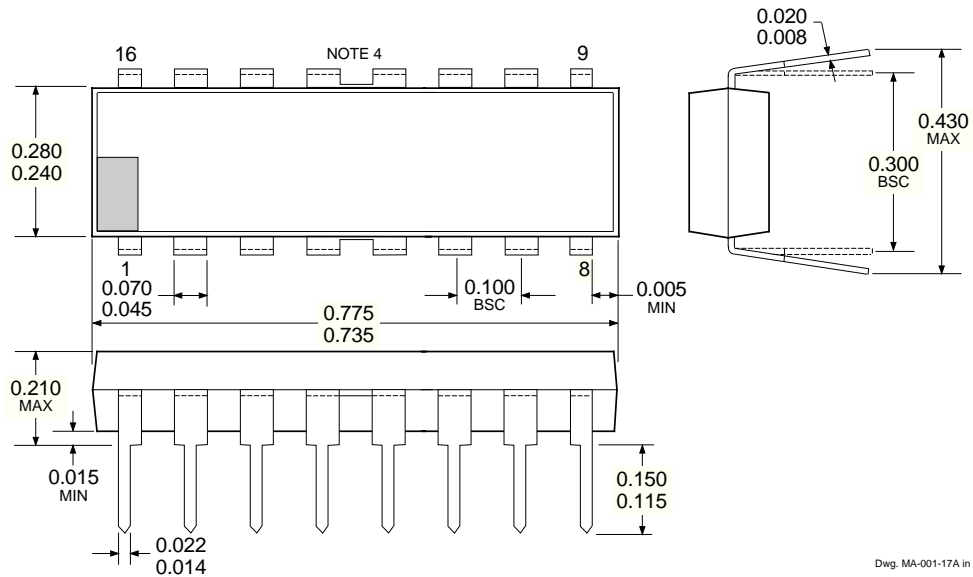

Dwg. MA-001-17A in

## Dimensions in Millimeters (for reference only)

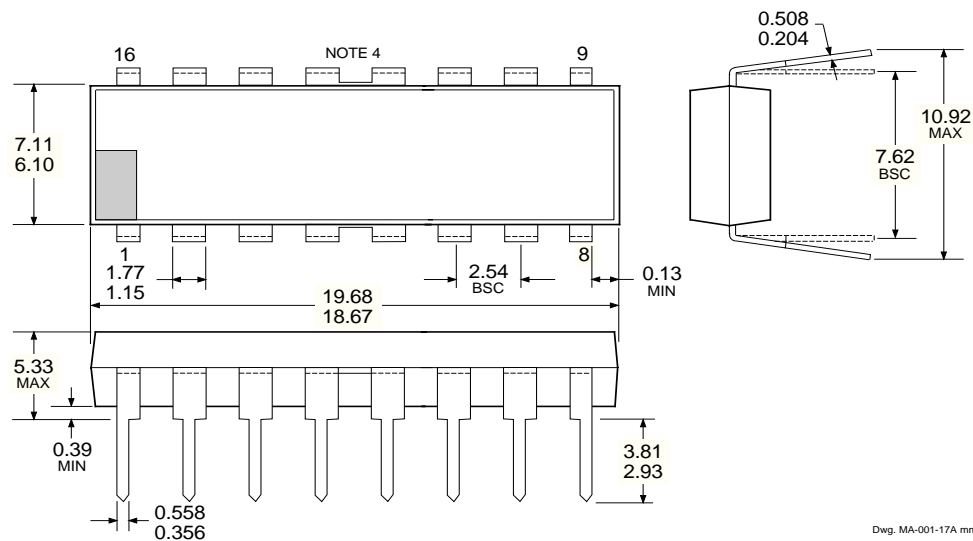

Dwg. MA-001-17A mm

- NOTES:
1. Exact body and lead configuration at vendor's option within limits shown.
  2. Lead spacing tolerance is non-cumulative
  3. Lead thickness is measured at seating plane or below.
  4. Webbed lead frame. Leads 4, 5, 12, and 13 are internally one piece.

**2961**  
**HIGH-CURRENT**  
**HALF-BRIDGE**  
**PRINTHEAD/MOTOR DRIVER**

**UDN2961W**  
 Dimensions in Inches  
 (controlling dimensions)

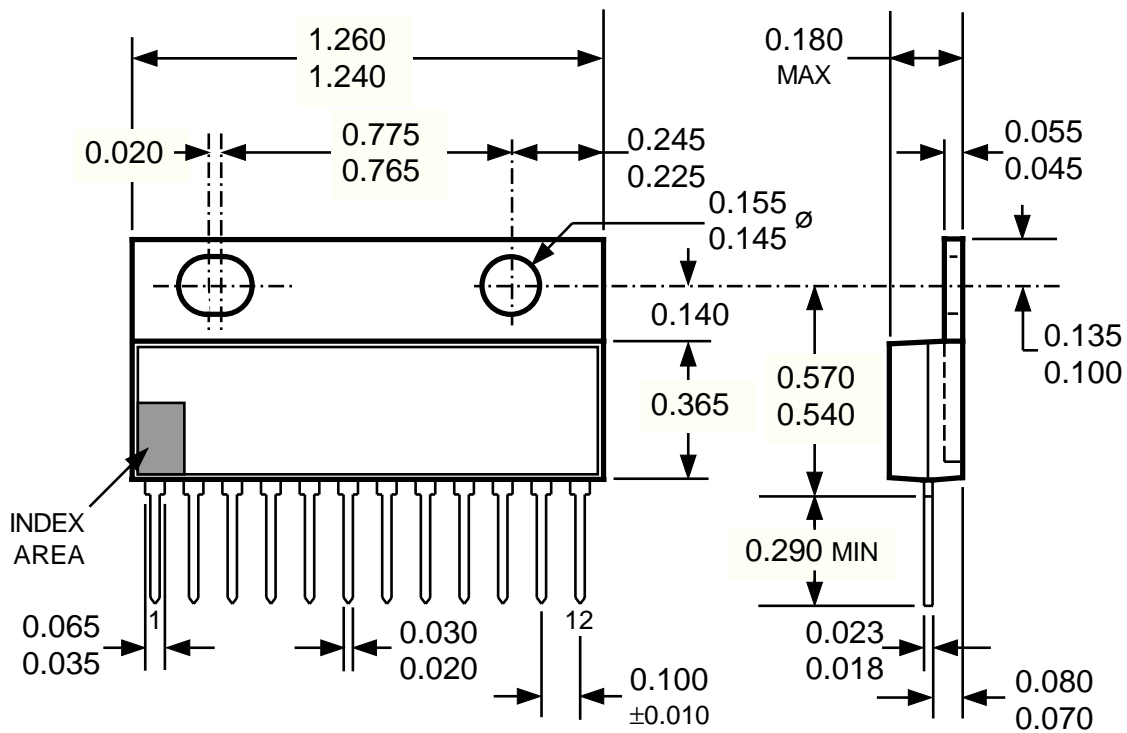

Dwg. MP-007 in

- NOTES:
1. Lead thickness is measured at seating plane or below.
  2. Lead spacing tolerance is non-cumulative
  3. Exact body and lead configuration at vendor's option within limits shown.
  4. Lead gauge plane is 0.030" below seating plane.



**2961**  
**HIGH-CURRENT**  
**HALF-BRIDGE**  
**PRINTHEAD/MOTOR DRIVER**

**UDN2961W**  
 Dimensions in Millimeters  
 (for reference only)

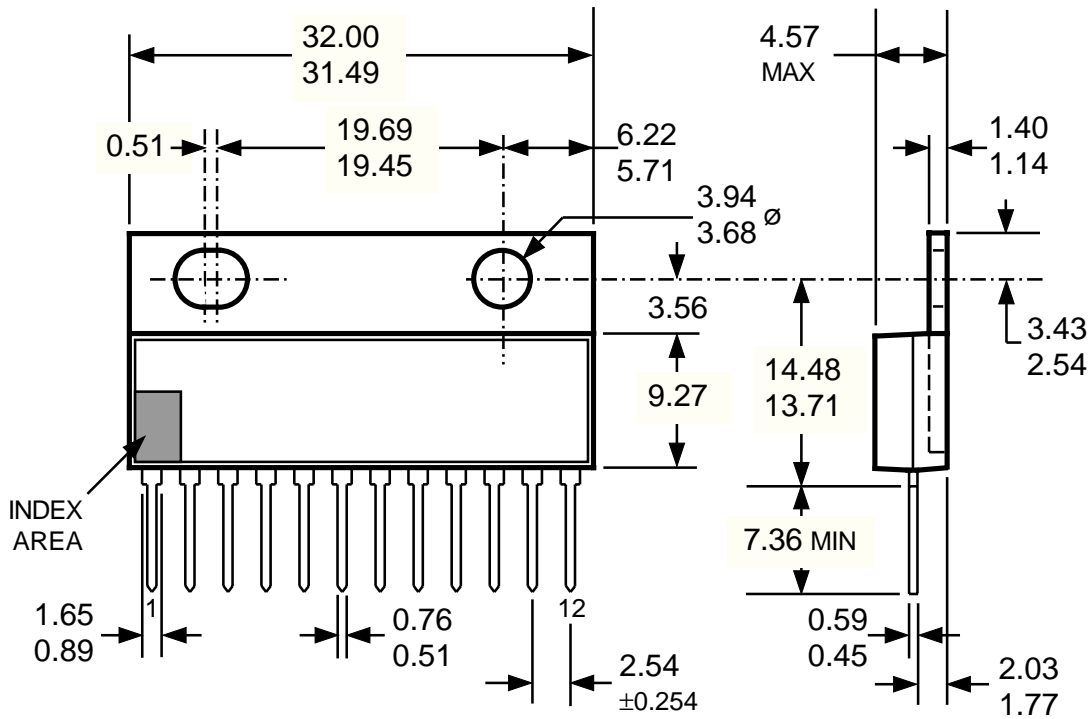

Dwg. MP-007 mm

- NOTES:
1. Lead thickness is measured at seating plane or below.
  2. Lead spacing tolerance is non-cumulative
  3. Exact body and lead configuration at vendor's option within limits shown.
  4. Lead gauge plane is 0.762 mm below seating plane.

**2961**  
***HIGH-CURRENT***  
***HALF-BRIDGE***  
***PRINthead/MOTOR DRIVER***

This page intentionally left blank



115 Northeast Cutoff, Box 15036  
Worcester, Massachusetts 01615-0036 (508) 853-5000

**2961**  
***HIGH-CURRENT***  
***HALF-BRIDGE***  
***PRINTHEAD/MOTOR DRIVER***

This page intentionally left blank

---

**2961**  
**HIGH-CURRENT**  
**HALF-BRIDGE**  
**PRINthead/MOTOR DRIVER**

**MOTOR DRIVERS SELECTION GUIDE**

Function	Output Ratings *		Part Number †
<b>INTEGRATED CIRCUITS FOR BRUSHLESS DC MOTORS</b>			
3-Phase Controller/Drivers	±2.0 A	45 V	2936 and 2936-120
Hall-Effect Latched Sensors	10 mA	24 V	3175 and 3177
2-Phase Hall-Effect Sensor/Controller	20 mA	25 V	3235
Hall-Effect Complementary-Output Sensor	20 mA	25 V	3275
2-Phase Hall-Effect Sensor/Driver	900 mA	14 V	3625
2-Phase Hall-Effect Sensor/Driver	400 mA	26 V	3626
Hall-Effect Complementary-Output Sensor/Driver	300 mA	60 V	5275
3-Phase Back-EMF Controller/Driver	±900 mA	14 V	8902-A
3-Phase Controller/DMOS Driver	±4.0 A	14 V	8925
3-Phase Back-EMF Controller/Driver	±1.0 A	7 V	8984
<b>INTEGRATED BRIDGE DRIVERS FOR DC AND BIPOLAR STEPPER MOTORS</b>			
PWM Current-Controlled Dual Full Bridge	±750 mA	45 V	2916
PWM Current-Controlled Dual Full Bridges	±1.5 A	45 V	2917 and 2918
PWM Current-Controlled Dual Full Bridge	±750 mA	45 V	2919
Dual Full-Bridge Driver	±2.0 A	50 V	2998
PWM Current-Controlled Full Bridge	±2.0 A	50 V	3952
PWM Current-Controlled Full Bridge	±1.3 A	50 V	3953
PWM Current-Controlled Microstepping Full Bridges	±1.5 A	50 V	3955 and 3957
PWM Current-Controlled Dual Full Bridge	±800 mA	33 V	3964
PWM Current-Controlled Dual Full Bridge	±650 mA	30 V	3966 and 3968
PWM Current-Controlled Dual Full Bridge	±750 mA	45 V	6219
<b>OTHER INTEGRATED CIRCUIT &amp; PMCM MOTOR DRIVERS</b>			
Unipolar Stepper-Motor Quad Driver	1.8 A	50 V	2544
Unipolar Stepper-Motor Translator/Driver	1.25 A	50 V	5804
Unipolar Stepper-Motor Quad Drivers	1 A	46 V	7024 and 7029
Unipolar Microstepper-Motor Quad Driver	1.2 A	46 V	7042
Voice-Coil Motor Driver	±500 mA	6 V	8932-A
Voice-Coil Motor Driver	±800 mA	16 V	8958
Voice-Coil (and Spindle) Motor Driver	±350 mA	7 V	8984

\* Current is maximum specified test condition, voltage is maximum rating. See specification for sustaining voltage limits or over-current protection voltage limits. Negative current is defined as coming out of (sourcing) the output.

† Complete part number includes additional characters to indicate operating temperature range and package style.

*Allegro MicroSystems, Inc. reserves the right to make, from time to time, such departures from the detail specifications as may be required to permit improvements in the design of its products.*

*The information included herein is believed to be accurate and reliable. However, Allegro MicroSystems, Inc. assumes no responsibility for its use; nor for any infringements of patents or other rights of third parties which may result from its use.*



115 Northeast Cutoff, Box 15036  
 Worcester, Massachusetts 01615-0036 (508) 853-5000