

**DESCRIPTION**

The MGF1601B, medium-power GaAs FET with an N-channel Schottky gate, is designed for use in S to X band amplifiers and oscillators. The hermetically sealed metalceramic package assures minimum parasitic losses, and has a configuration suitable for microstrip circuits.

**FEATURES**

- High output power at 1dB gain compression  
 $P_{1dB}=21.8dBm(TYP.)$  @ $f=8GHz$
- High linear power gain  
 $GLP=8dB(TYP.)$  @ $f=8GHz$

**APPLICATION**

S to X band medium-power amplifiers and oscillators.

**QUALITY GRADE**

- GG

**RECOMMENDED BIAS CONDITIONS**

- $V_{DS}=6V$
- $I_D=100mA$
- Refer to Bias Procedure

**OUTLINE DRAWING**

Unit: millimeters

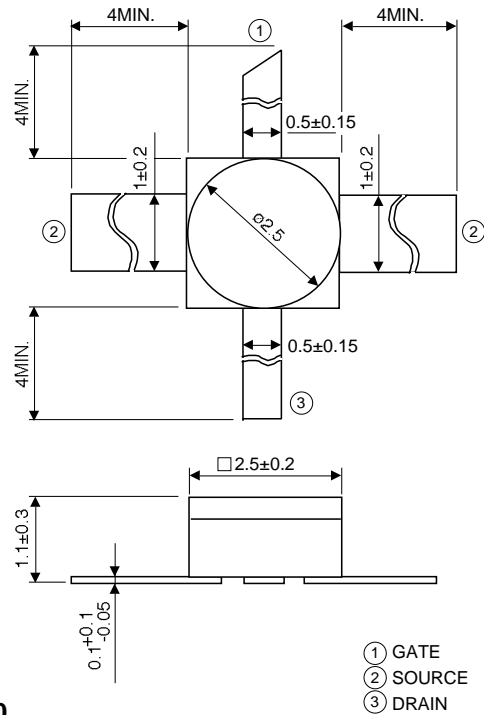

**GD-10**

**ABSOLUTE MAXIMUM RATINGS** ( $T_a=25^{\circ}C$ )

Symbol	Parameter	Ratings	Unit
$V_{GDO}$	Gate to drain voltage	-8	V
$V_{GSO}$	Gate to source voltage	-8	V
$I_D$	Drain current	250	mA
$I_{GR}$	Reverse gate current	-0.6	mA
$I_{GF}$	Forward gate current	1.5	mA
$P_T$	Total power dissipation *1	1.2	W
$T_{ch}$	Channel temperature	175	$^{\circ}C$
$T_{stg}$	Storage temperature	-65 to +175	$^{\circ}C$

\*1:  $T_C=25^{\circ}C$

**ELECTRICAL CHARACTERISTICS** ( $T_a=25^{\circ}C$ )

Symbol	Parameter	Test conditions	Limits			Unit
			Min	Typ	Max	
$V_{(BR)GDO}$	Gate to drain breakdown voltage	$I_G=-200\mu A$	-8	-	-	V
$V_{(BR)GSO}$	Gate to source breakdown voltage	$I_G=-200\mu A$	-8	-	-	V
$I_{GSS}$	Gate to source leakage current	$V_{GS}=-3V, V_{DS}=0V$	-	-	20	$\mu A$
$I_{DSS}$	Saturated drain current	$V_{GS}=0V, V_{DS}=3V$	150	200	250	mA
$V_{GS(off)}$	Gate source cut-off voltage	$V_{DS}=3V, I_D=100\mu A$	-1.5	-	-4.5	V
$g_m$	Transconductance	$V_{DS}=3V, I_D=100mA$	70	90	-	mS
$GLP$	Linear power gain	$V_{DS}=6V, I_D=100mA, f=8GHz$	6	8	-	dB
$P_{1dB}$	Output power at 1dB gain compression	$V_{DS}=6V, I_D=100mA, f=8GHz$	20.8	21.8	-	dBm
$R_{th(ch-c)}$	Thermal resistance *1	$V_f$ method	-	-	125	$^{\circ}C/W$

\*1: Channel to ambient

**TYPICAL CHARACTERISTICS** ( $T_a=25^\circ\text{C}$ )

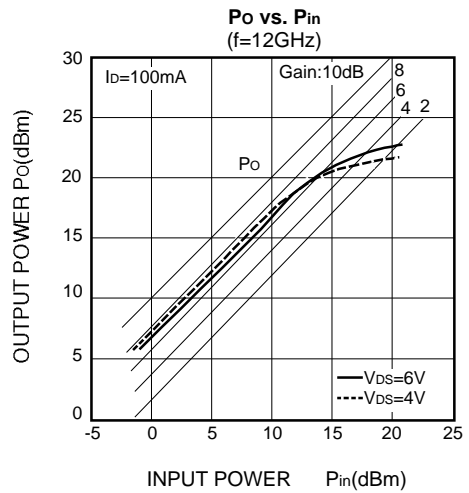
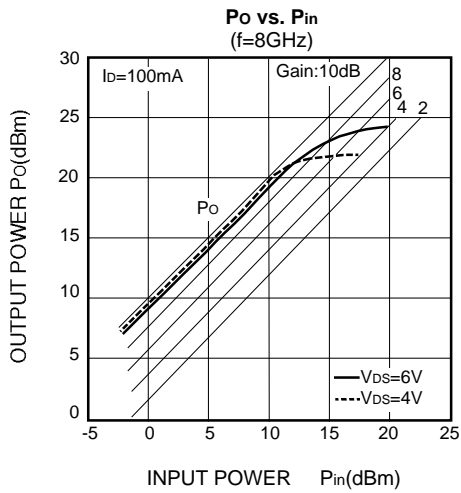
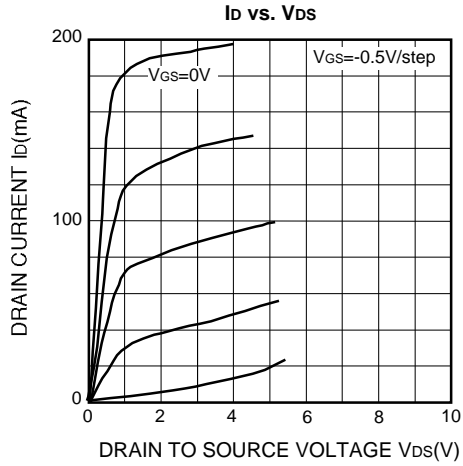

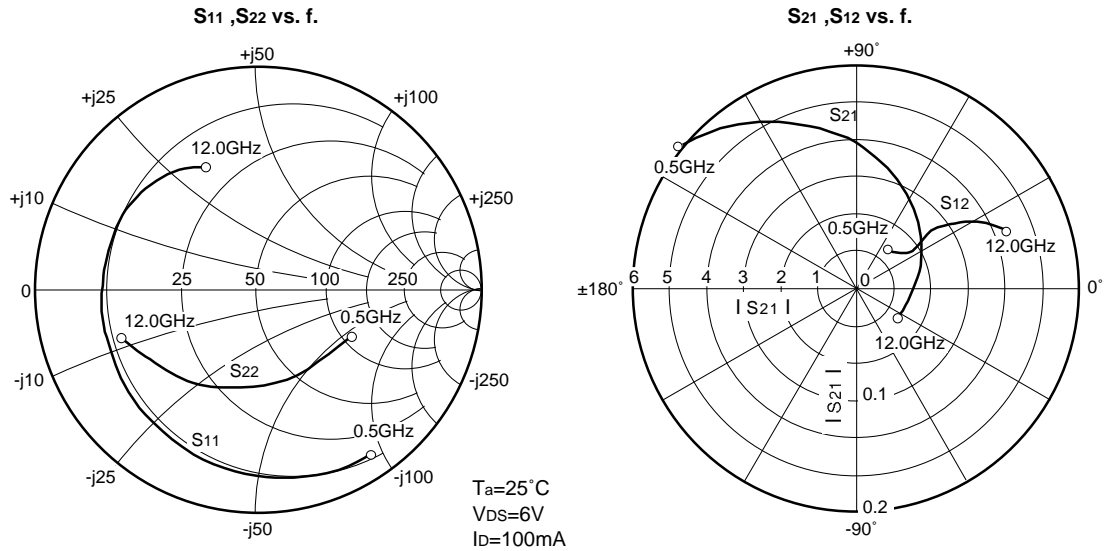

**S PARAMETERS** ( $T_a=25^\circ\text{C}, V_{DS}=6\text{V}, I_D=100\text{mA}$ )

Freq. (GHz)	S11		S21		S12		S22		K	MSG/MAG (dB)
	Magn.	Angle(deg.)	Magn.	Angle(deg.)	Magn.	Angle(deg.)	Magn.	Angle(deg.)		
0.5	0.899	-56.8	6.115	140.3	0.047	52.1	0.471	-25.2	0.371	21.2
1.0	0.874	-69.4	5.682	130.4	0.049	49.3	0.462	-32.7	0.394	20.7
1.5	0.848	-82.1	5.248	120.5	0.050	46.4	0.452	-40.1	0.431	20.2
2.0	0.822	-94.7	4.815	110.6	0.052	43.6	0.442	-47.5	0.485	19.7
2.5	0.796	-107.4	4.382	100.6	0.054	40.8	0.432	-54.9	0.558	19.1
3.0	0.771	-120.0	3.949	90.8	0.056	38.0	0.422	-62.4	0.657	18.5
3.5	0.745	-132.7	3.515	80.9	0.057	35.1	0.413	-69.8	0.789	17.9
4.0	0.719	-145.3	3.082	71.0	0.059	32.3	0.403	-77.2	0.964	17.2
4.5	0.713	-153.3	2.863	63.3	0.060	33.3	0.412	-84.2	1.006	16.3
5.0	0.706	-161.3	2.645	55.6	0.062	34.3	0.421	-91.1	1.064	14.8
5.5	0.700	-169.3	2.426	47.9	0.063	35.2	0.431	-98.1	1.142	13.6
6.0	0.694	-177.3	2.207	40.2	0.064	36.2	0.440	-105.0	1.245	12.4
6.5	0.691	176.9	2.090	33.9	0.068	37.6	0.458	-110.3	1.202	12.1
7.0	0.689	171.1	1.973	27.5	0.073	39.0	0.476	-115.5	1.172	11.8
7.5	0.686	165.2	1.856	21.2	0.077	40.4	0.494	-120.8	1.153	11.5
8.0	0.683	159.4	1.739	14.8	0.081	41.8	0.512	-126.0	1.146	11.0
8.5	0.677	153.1	1.671	8.5	0.089	40.5	0.530	-130.8	1.072	11.1
9.0	0.670	146.9	1.602	2.1	0.096	39.3	0.549	-135.5	1.011	11.6
9.5	0.664	140.6	1.534	-4.3	0.104	38.0	0.567	-140.3	0.962	11.7
10.0	0.657	134.3	1.466	-10.6	0.111	36.7	0.585	-145.0	0.922	11.2
10.5	0.645	127.8	1.413	-17.0	0.118	33.2	0.601	-149.4	0.893	10.8
11.0	0.632	121.3	1.360	-23.4	0.126	29.8	0.618	-153.9	0.867	10.4
11.5	0.620	114.8	1.308	-29.7	0.133	26.3	0.635	-158.3	0.844	9.9
12.0	0.608	108.3	1.255	-36.1	0.140	22.8	0.651	-162.7	0.823	9.5