HD74AC374/HD74ACT374

Octal D-Type Flip-Flops with 3-State Output

HITACHI

Description

The HD74AC374/HD74ACT374 is a high-speed, low-power octal D-type flip-flop featuring separate D-type inputs for each flip-flop and 3-state outputs for bus-oriented applications. A buffered Clock (CP) and Output Enable (\overline{OE}) are common to all flip-flops.

Features

- Buffered Positive Edge-Triggered Clock
- 3-State Outputs for Bus-Oriented Applications
- Outputs Source/Sink 24 mA
- See HD74AC273/HD74ACT273 for Reset Version
- See HD74AC373/HD74ACT373 for Transparent Latch Version
- See HD74AC574/HD74ACT574 for Broadside Pinout Version
- See HD74AC564/HD74ACT564 for Broadside
- Pinout Version with Inverted Outputs
- HD74ACT374 has TTL-Compatible Inputs

HD74AC374/HD74ACT374

Pin Arrangement

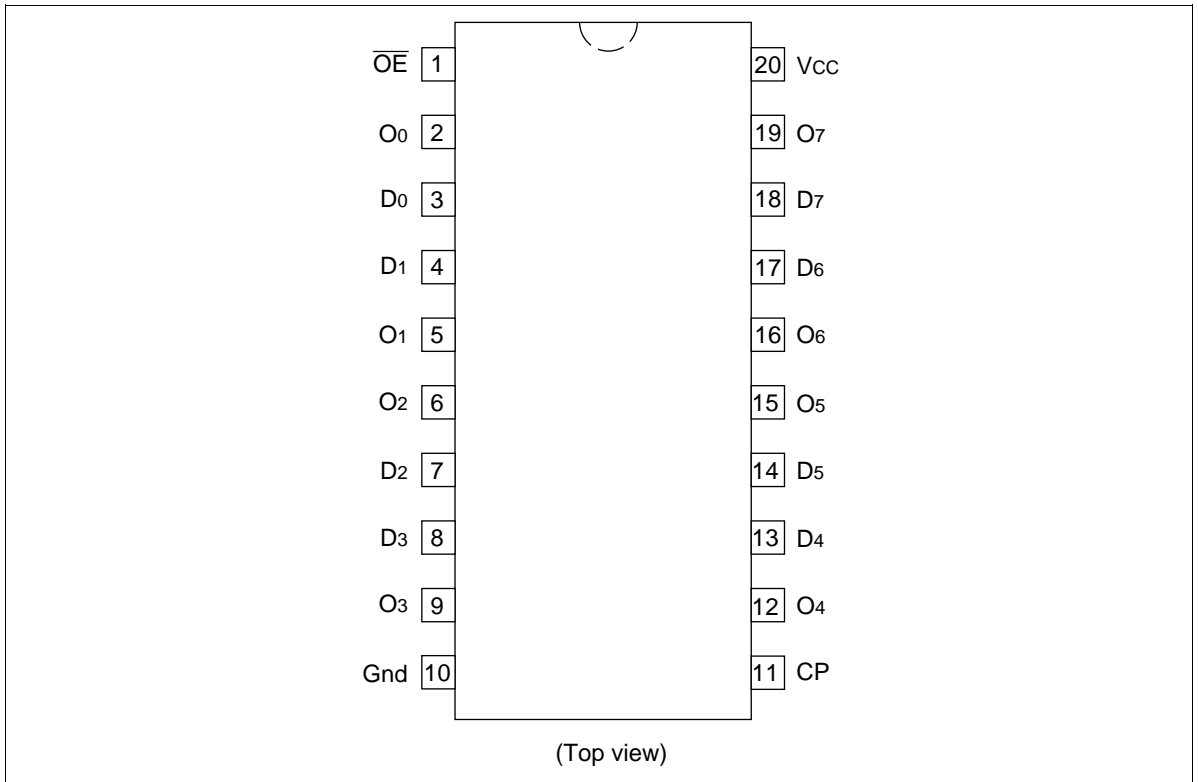

Logic Symbol

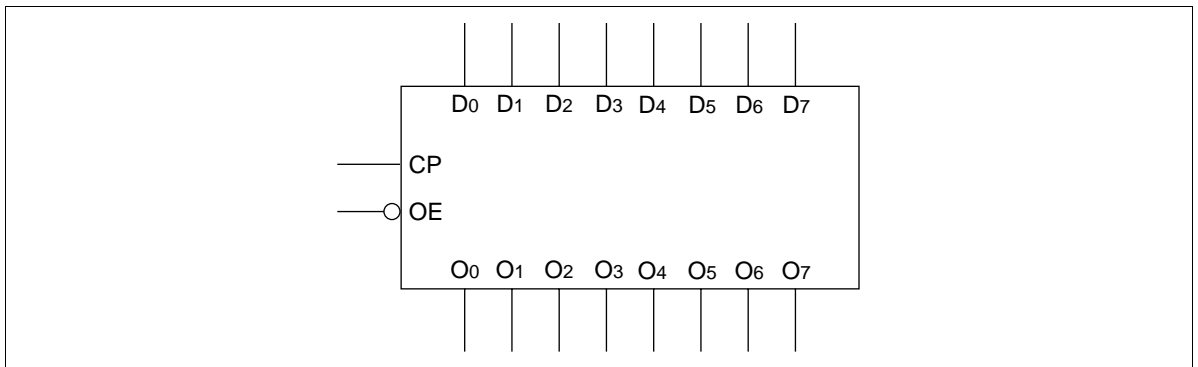

Pin Names



- D₀ – D₇ Data Inputs
- CP Clock Pulse Input
- \overline{OE} 3-State Output Enable Input
- O₀ – O₇ 3-State Outputs

HITACHI

Functional Description

The HD74AC374/HD74ACT374 consists of eight edge-triggered flip-flops with individual D-type inputs and 3-state true outputs. The buffered clock and buffered Output Enable are common to all flip-flops. The eight flip-flops will store the state of their individual D inputs that meet the setup and hold time requirements on the Low-to-High Clock (CP) transition. With the Output Enable (\overline{OE}) Low, the contents of the eight flip-flops are available at the outputs. When the \overline{OE} is High, the outputs go to the high impedance state. Operation of the \overline{OE} input does not affect the state of the flip-flops.

Truth Table

Inputs			Outputs
D_n	CP	\overline{OE}	O_n
H		L	H
L		L	L
X	X	H	Z

H : High Voltage Level

L : Low Voltage Level

X : Immaterial

Z : High Impedance

 : Low-to-High Transition

Logic Diagram

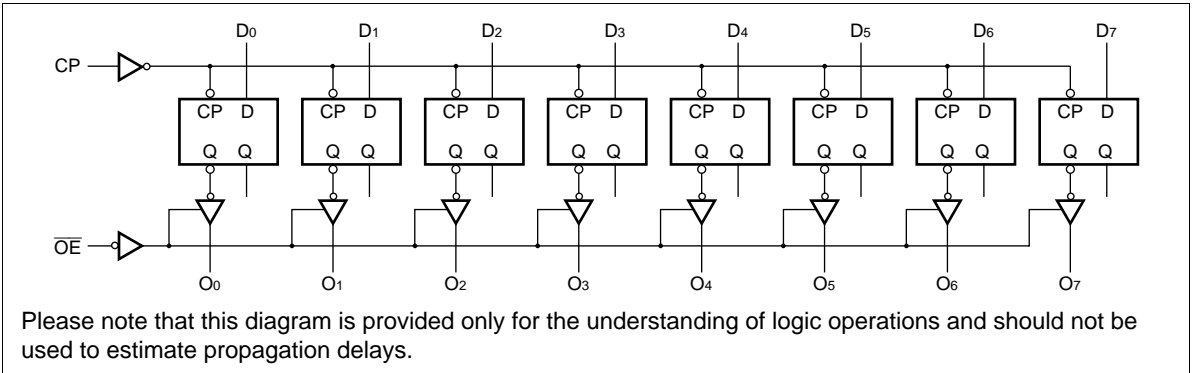

HD74AC374/HD74ACT374

DC Characteristics (unless otherwise specified)

Item	Symbol	Max	Unit	Condition
Maximum quiescent supply current	I_{CC}	80	μA	$V_{IN} = V_{CC}$ or ground, $V_{CC} = 5.5\text{ V}$, $T_a = \text{Worst case}$
Maximum quiescent supply current	I_{CC}	8.0	μA	$V_{IN} = V_{CC}$ or ground, $V_{CC} = 5.5\text{ V}$, $T_a = 25^\circ\text{C}$
Maximum I_{CC}/input (HD74ACT374)	I_{CCT}	1.5	mA	$V_{IN} = V_{CC} - 2.1\text{ V}$, $V_{CC} = 5.5\text{ V}$, $T_a = \text{Worst case}$

AC Characteristics: HD74AC374

Item	Symbol	$V_{CC} (\text{V})^{*1}$	$T_a = +25^\circ\text{C}$ $C_L = 50\text{ pF}$			$T_a = -40^\circ\text{C to } +85^\circ\text{C}$ $C_L = 50\text{ pF}$		Unit
			Min	Typ	Max	Min	Max	
Maximum clock frequency	f_{max}	3.3	60	110	—	60	—	MHz
		5.0	100	155	—	100	—	
Propagation delay CP to O_n	t_{PLH}	3.3	1.0	11.0	13.5	1.0	15.5	ns
		5.0	1.0	8.0	9.5	1.0	10.5	
Propagation delay CP to O_n	t_{PHL}	3.3	1.0	10.0	12.5	1.0	14.0	ns
		5.0	1.0	7.0	9.0	1.0	10.0	
Output enable time	t_{PZH}	3.3	1.0	9.5	11.5	1.0	13.0	ns
		5.0	1.0	7.0	8.5	1.0	9.5	
Output enable time	t_{PZL}	3.3	1.0	9.0	11.5	1.0	13.0	ns
		5.0	1.0	6.5	8.5	1.0	9.5	
Output disable time	t_{PHZ}	3.3	1.0	10.5	12.5	1.0	14.5	ns
		5.0	1.0	8.0	11.0	1.0	12.5	
Output disable time	t_{PLZ}	3.3	1.0	8.0	11.5	1.0	12.5	ns
		5.0	1.0	6.5	8.5	1.0	10.0	

Note: 1. Voltage Range 3.3 is $3.3\text{ V} \pm 0.3\text{ V}$
Voltage Range 5.0 is $5.0\text{ V} \pm 0.5\text{ V}$

AC Operating Requirements: HD74AC374

Item	Symbol	V _{CC} (V)*1	Ta = +25°C	Ta = -40°C		Unit
			C _L = 50 pF	to +85°C	C _L = 50 pF	
			Typ	Guaranteed Minimum		
Setup time, HIGH or LOW	t _{su}	3.3	2.0	5.5	6.0	ns
D _n to CP		5.0	1.0	4.0	4.5	
Hold time, HIGH or LOW	t _h	3.3	-1.0	1.0	1.0	ns
D _n to CP		5.0	-4.0	1.5	1.5	
CP pulse width, HIGH or LOW	t _w	3.3	4.0	5.5	6.0	ns
		5.0	2.5	4.0	4.5	

Note: 1. Voltage Range 3.3 is 3.3 V ± 0.3 V
Voltage Range 5.0 is 5.0 V ± 0.5 V

AC Characteristics: HD74ACT374

Item	Symbol	V _{CC} (V)*1	Ta = +25°C			Ta = -40°C to +85°C		Unit
			C _L = 50 pF			C _L = 50 pF		
			Min	Typ	Max	Min	Max	
Maximum clock frequency	f _{max}	5.0	100	160	—	90	—	MHz
Propagation delay CP to O _n	t _{PLH}	5.0	1.0	8.5	10.0	1.0	11.5	ns
Propagation delay CP to O _n	t _{PHL}	5.0	1.0	8.0	9.5	1.0	11.0	ns
Output enable time	t _{PZH}	5.0	1.0	8.0	9.5	1.0	10.5	ns
Output enable time	t _{PZL}	5.0	1.0	8.0	9.0	1.0	10.5	ns
Output disable time	t _{PHZ}	5.0	1.0	8.5	11.5	1.0	12.5	ns
Output disable time	t _{PLZ}	5.0	1.0	7.0	8.5	1.0	10.0	ns

Note: 1. Voltage Range 5.0 is 5.0 V ± 0.5 V

HD74AC374/HD74ACT374

AC Operating Requirements: HD74ACT374

Item	Symbol	V_{CC} (V)*1	Ta = +25°C CL = 50 pF		Ta = -40°C to +85°C CL = 50 pF	
			Typ	Guaranteed Minimum	Guaranteed Minimum	Unit
Setup time, HIGH or LOW D _n to CP	t _{su}	5.0	1.0	7.0	5.5	ns
Hold time, HIGH or LOW D _n to CP	t _h	5.0	0.0	1.5	1.5	ns
CP pulse width, HIGH or LOW	t _w	5.0	2.0	7.0	5.0	ns

Note: 1. Voltage Range 5.0 is 5.0 V ± 0.5 V

Capacitance

Item	Symbol	Typ	Unit	Condition
Input capacitance	C _{IN}	4.5	pF	V _{CC} = 5.5 V
Power dissipation capacitance	C _{PD}	80.0	pF	V _{CC} = 5.0 V

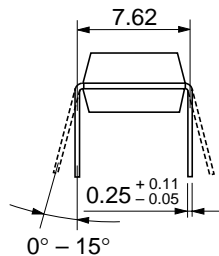
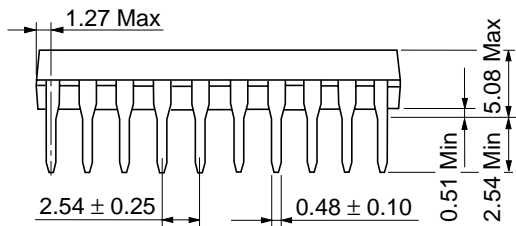
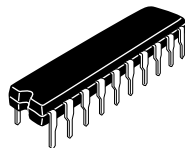
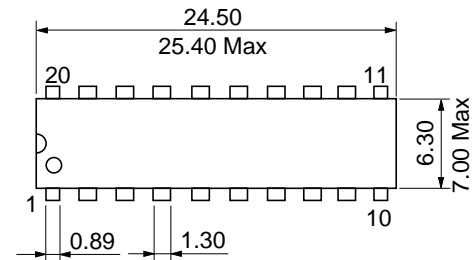

Hitachi Code	DP-20N
JEDEC	—
EIAJ	Conforms
Weight (reference value)	1.26 g

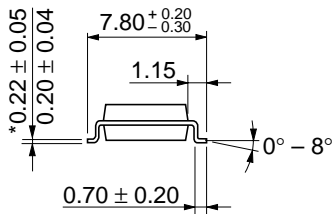
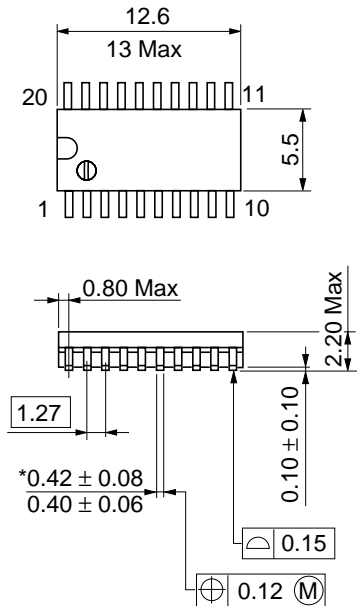

Hitachi Code	FP-20DA
JEDEC	—
EIAJ	Conforms
Weight (reference value)	0.31 g

*Dimension including the plating thickness
Base material dimension

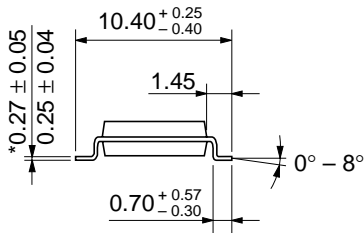
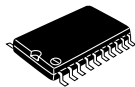
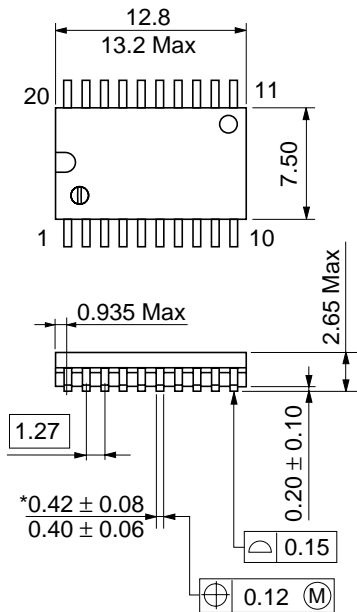

Hitachi Code	FP-20DB
JEDEC	Conforms
EIAJ	—
Weight (reference value)	0.52 g

*Dimension including the plating thickness
 Base material dimension

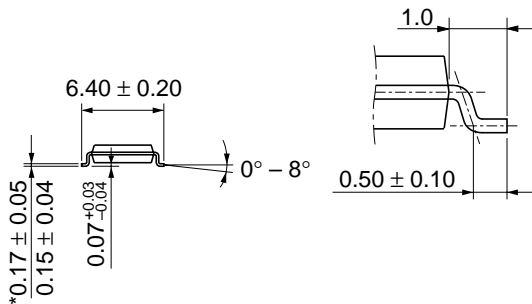
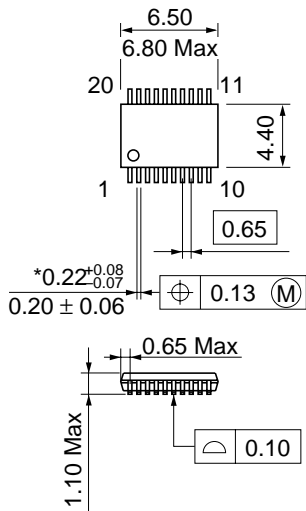

*Dimension including the plating thickness
Base material dimension

Hitachi Code	TTP-20DA
JEDEC	—
EIAJ	—
Weight (reference value)	0.07 g

Cautions

1. Hitachi neither warrants nor grants licenses of any rights of Hitachi's or any third party's patent, copyright, trademark, or other intellectual property rights for information contained in this document. Hitachi bears no responsibility for problems that may arise with third party's rights, including intellectual property rights, in connection with use of the information contained in this document.
2. Products and product specifications may be subject to change without notice. Confirm that you have received the latest product standards or specifications before final design, purchase or use.
3. Hitachi makes every attempt to ensure that its products are of high quality and reliability. However, contact Hitachi's sales office before using the product in an application that demands especially high quality and reliability or where its failure or malfunction may directly threaten human life or cause risk of bodily injury, such as aerospace, aeronautics, nuclear power, combustion control, transportation, traffic, safety equipment or medical equipment for life support.
4. Design your application so that the product is used within the ranges guaranteed by Hitachi particularly for maximum rating, operating supply voltage range, heat radiation characteristics, installation conditions and other characteristics. Hitachi bears no responsibility for failure or damage when used beyond the guaranteed ranges. Even within the guaranteed ranges, consider normally foreseeable failure rates or failure modes in semiconductor devices and employ systemic measures such as fail-safes, so that the equipment incorporating Hitachi product does not cause bodily injury, fire or other consequential damage due to operation of the Hitachi product.
5. This product is not designed to be radiation resistant.
6. No one is permitted to reproduce or duplicate, in any form, the whole or part of this document without written approval from Hitachi.
7. Contact Hitachi's sales office for any questions regarding this document or Hitachi semiconductor products.

HITACHI

Hitachi, Ltd.

Semiconductor & Integrated Circuits.
Nippon Bldg., 2-6-2, Ohte-machi, Chiyoda-ku, Tokyo 100-0004, Japan
Tel: Tokyo (03) 3270-2111 Fax: (03) 3270-5109

URL North America : <http://semiconductor.hitachi.com/>
 Europe : <http://www.hitachi-eu.com/hel/ecg>
 Asia (Singapore) : <http://www.has.hitachi.com.sg/grp3/sicd/index.htm>
 Asia (Taiwan) : http://www.hitachi.com.tw/E/Product/SICD_Frame.htm
 Asia (HongKong) : <http://www.hitachi.com.hk/eng/bo/grp3/index.htm>
 Japan : <http://www.hitachi.co.jp/Sicd/indx.htm>

For further information write to:

Hitachi Semiconductor
(America) Inc.
179 East Tasman Drive,
San Jose, CA 95134
Tel: <1> (408) 433-1990
Fax: <1> (408) 433-0223

Hitachi Europe GmbH
Electronic components Group
Dornacher Straße 3
D-85622 Feldkirchen, Munich
Germany
Tel: <49> (89) 9 9180-0
Fax: <49> (89) 9 29 30 00

Hitachi Europe Ltd.
Electronic Components Group.
Whitebrook Park
Lower Cookham Road
Maidenhead
Berkshire SL6 8YA, United Kingdom
Tel: <44> (1628) 585000
Fax: <44> (1628) 778322

Hitachi Asia Pte. Ltd.
16 Collyer Quay #20-00
Hitachi Tower
Singapore 049318
Tel: 535-2100
Fax: 535-1533

Hitachi Asia Ltd.
Taipei Branch Office
3F, Hung Kuo Building, No.167,
Tun-Hwa North Road, Taipei (105)
Tel: <886> (2) 2718-3666
Fax: <886> (2) 2718-8180

Hitachi Asia (Hong Kong) Ltd.
Group III (Electronic Components)
7/F., North Tower, World Finance Centre,
Harbour City, Canton Road, Tsim Sha Tsui,
Kowloon, Hong Kong
Tel: <852> (2) 735 9218
Fax: <852> (2) 730 0281
Telex: 40815 HITEC HX

Copyright ' Hitachi, Ltd., 1999. All rights reserved. Printed in Japan.

HITACHI