



# ITA6V1U1

Application Specific Discretes  
A.S.D.<sup>TM</sup>

## TRANSIL<sup>TM</sup> ARRAY FOR DATALINE PROTECTION

### APPLICATIONS

Data transmission lines protection :

- Unipolar signal up to 5.5V
- Bipolar signal in the +/- 2.5V range

### FEATURES

- HIGH SURGE CAPABILITY TRANSIL ARRAY  
 $I_{PP} = 40\text{ A}$  (8/20 $\mu\text{s}$ )
- PEAK PULSE POWER : 300 W (8/20 $\mu\text{s}$ )
- UP TO 6 UNIDIRECTIONAL TRANSIL FUNCTIONS
- LOW CLAMPING FACTOR ( $V_{CL} / V_{BR}$ ) AT HIGH CURRENT LEVEL
- LOW LEAKAGE CURRENT
- ESD PROTECTION UP TO 15kV

### DESCRIPTION

Transil diode arrays provide high overvoltage protection by clamping action. Their instantaneous response to transient overvoltages makes them particularly suited to protect voltage sensitive devices such as MOS Technology and low voltage supplied IC's.

The ITA series allies high surge capability against energetic pulses with high voltage performance against ESD.

### COMPLIES WITH THE FOLLOWING STANDARDS :

IEC 1000-4-2 : level 4  
IEC 1000-4-4 : level 4  
IEC 1000-4-5 : level 2

MIL STD 883C - Method 3015-6 : class 3  
(human body model)

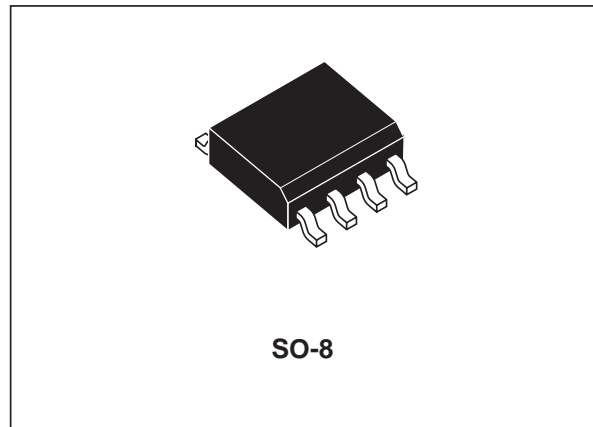

### FUNCTIONAL DIAGRAM

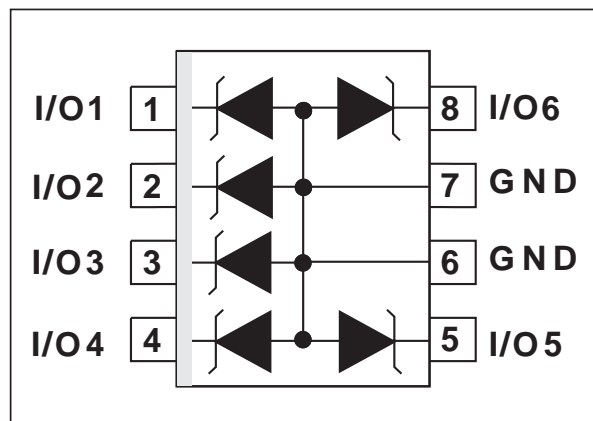

# ITA6V1U1

## ABSOLUTE MAXIMUM RATINGS (T<sub>amb</sub> = 25°C)

Symbol	Parameter		Value	Unit
P <sub>PP</sub>	Peak pulse power dissipation (8/20μs) (see note 1)	T <sub>j</sub> initial = T <sub>amb</sub>	300	W
I <sub>PP</sub>	Peak pulse current (8/20μs) (see note 1)	T <sub>j</sub> initial = T <sub>amb</sub>	40	A
I <sup>2</sup> t	Wire I <sup>2</sup> t value (see note 1)		0.6	A <sup>2</sup> s
T <sub>stg</sub> T <sub>j</sub>	Storage temperature range Maximum operating junction temperature		- 55 to + 150 125	°C °C
T <sub>L</sub>	Maximum lead temperature for soldering during 10s		260	°C

**Note 1 :** For surges greater than the specified maximum value, the I/O will first present a short-circuit and after an open circuit caused by the wire melting.

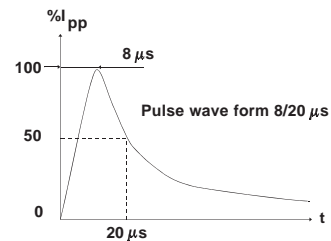

## ELECTRICAL CHARACTERISTICS (T<sub>amb</sub> = 25°C)

Symbol	Parameter
V <sub>RM</sub>	Stand-off voltage
V <sub>BR</sub>	Breakdown voltage
V <sub>CL</sub>	Clamping voltage
I <sub>RM</sub>	Leakage current @ V <sub>RM</sub>
I <sub>PP</sub>	Peak pulse current
αT	Voltage temperature coefficient
C	Junction capacitance
V <sub>F</sub>	Forward voltage drop

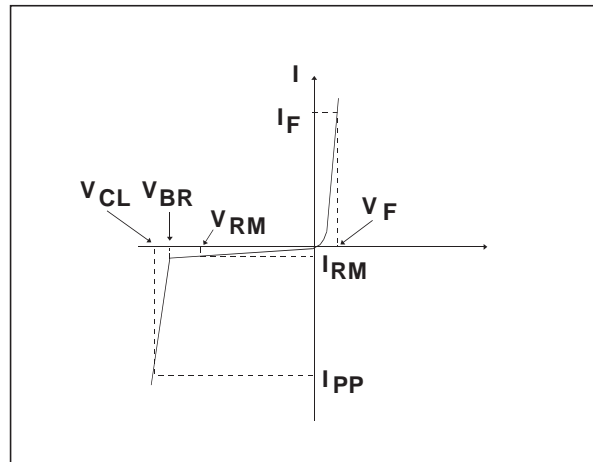

Types	I <sub>RM</sub> @ V <sub>RM</sub>	V <sub>BR</sub> @ I <sub>R</sub>	V <sub>CL</sub> @ I <sub>PP</sub>	V <sub>CL</sub> @ I <sub>PP</sub>	αT	C	V <sub>F</sub> @ I <sub>F</sub>	
	max.	min.	max.	max.			max.	max.
	μA	V	V	V	10 <sup>-4</sup> /°C	pF	V	A
ITA6V1U1	10	6.1	10	12	4	1500	1.3	1

**Note 2 :** Between I/O pin and ground.

**Note 3 :** Between I/O pin and ground, at 0V Bias. F = 1MHz.

**Fig. 1 :** Typical peak power versus exponential pulse duration.

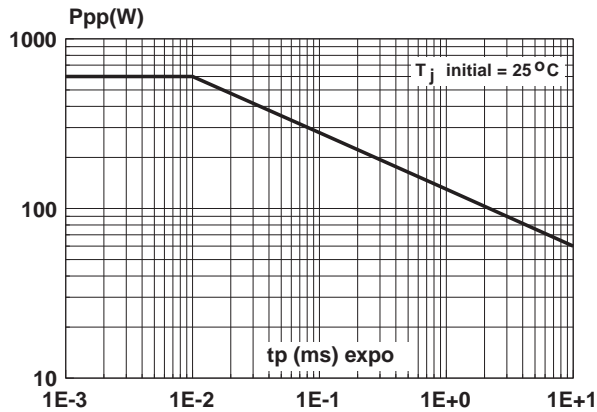

**Fig. 2 :** Clamping voltage versus peak pulse current (exponential waveform 8/20 μs).

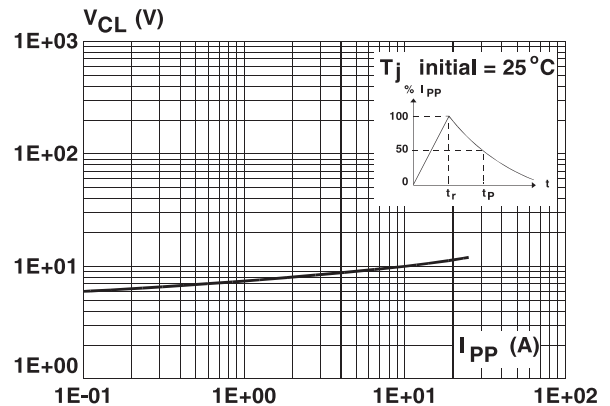

**Fig. 3 :** Peak current I<sub>DC</sub> inducing open circuit of the wire for one input/output versus pulse duration (typical values).

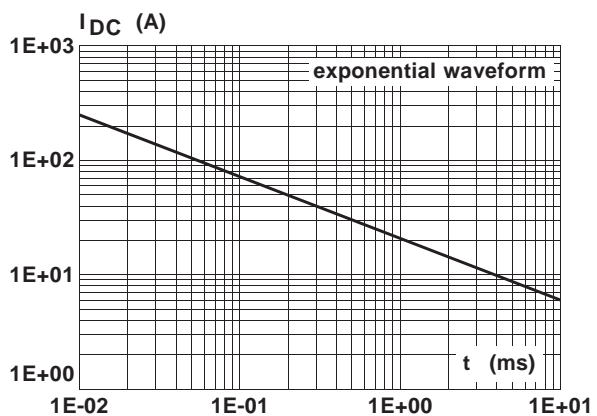

**Fig. 4 :** Junction capacitance versus reverse applied voltage for one input/output (typical values).

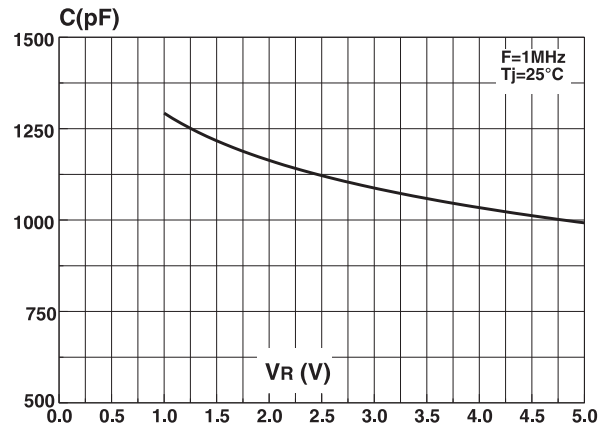

**Fig. 5 :** Relative variation of leakage current versus junction temperature

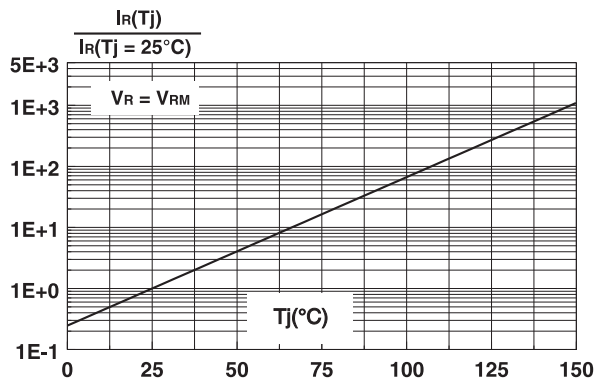

# ITA6V1U1

## APPLICATION INFORMATION

### Typical application 1 : $\mu$ P I/O lines

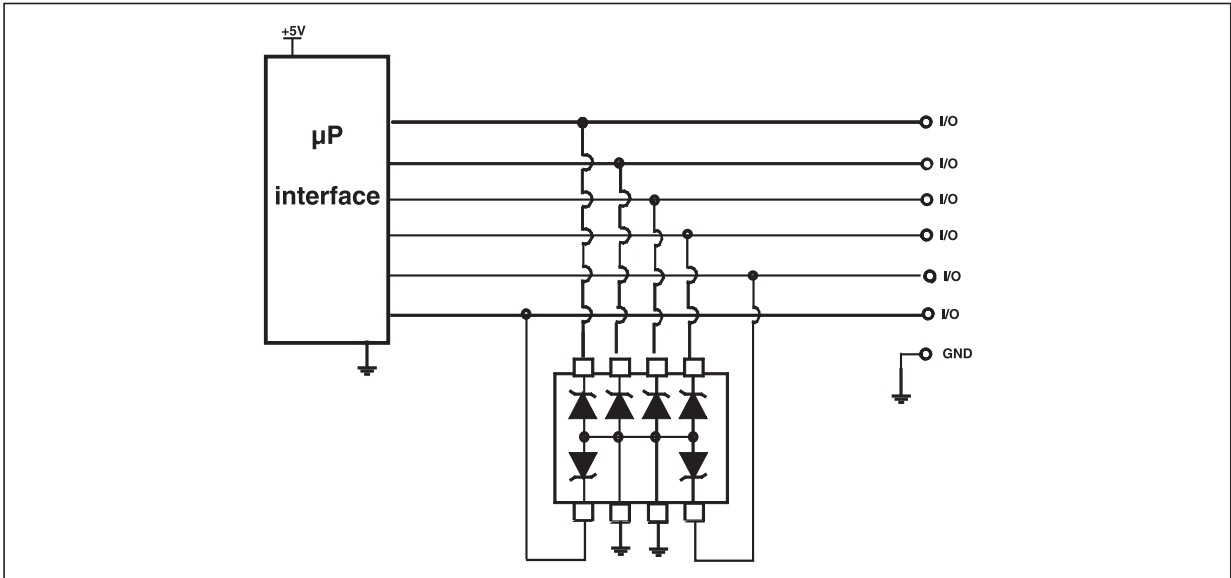

### Typical application 2 : +/-2.5V Data lines

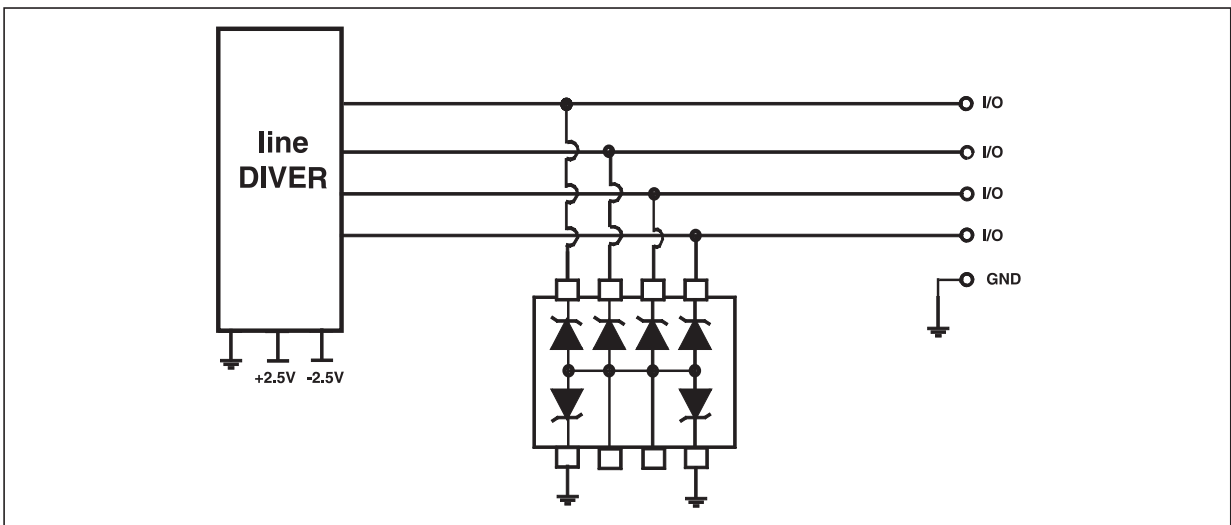

## ORDER CODE

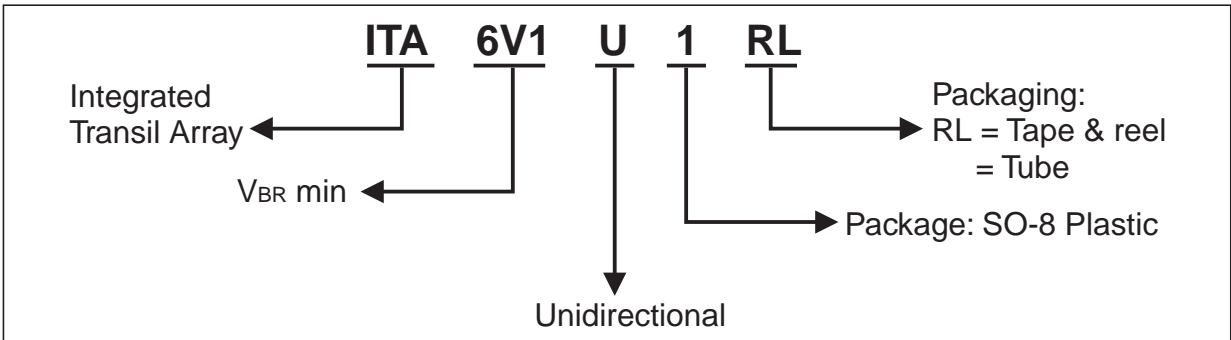

**MARKING**

TYPE	MARKING
ITA6V1U1	6V1U1

**Packaging :** Preferred packaging is tape and reel.  
**Weight :** 0.08g.

**PACKAGE MECHANICAL DATA**  
 SO-8 (Plastic)

REF.	DIMENSIONS					
	Millimetres			Inches		
	Min.	Typ.	Max.	Min.	Typ.	Max.
A			1.75			0.069
a1	0.1		0.25	0.004		0.010
a2			1.65			0.065
b	0.35		0.48	0.014		0.019
b1	0.19		0.25	0.007		0.010
C		0.50			0.020	
c1	45° (typ)					
D	4.8		5.0	0.189		0.197
E	5.8		6.2	0.228		0.244
e		1.27			0.050	
e3		3.81			0.150	
F	3.8		4.0	0.15		0.157
L	0.4		1.27	0.016		0.050
M			0.6			0.024
S	8° (max)					

Information furnished is believed to be accurate and reliable. However, STMicroelectronics assumes no responsibility for the consequences of use of such information nor for any infringement of patents or other rights of third parties which may result from its use. No license is granted by implication or otherwise under any patent or patent rights of STMicroelectronics. Specifications mentioned in this publication are subject to change without notice. This publication supersedes and replaces all information previously supplied. STMicroelectronics products are not authorized for use as critical components in life support devices or systems without express written approval of STMicroelectronics.

The ST logo is a registered trademark of STMicroelectronics  
 © 2001 STMicroelectronics - Printed in Italy - All rights reserved.

STMicroelectronics GROUP OF COMPANIES  
 Australia - Brazil - China - Finland - France - Germany - Hong Kong - India - Italy - Japan - Malaysia  
 Malta - Morocco - Singapore - Spain - Sweden - Switzerland - United Kingdom - U.S.A.

<http://www.st.com>

