

5-Bit, 4-Port Bus Exchange Switch

Features

- Near-Zero propagation delay
- 5Ω switches connect inputs to outputs
- Direct bus connection when switches are ON
- Ultra-low quiescent power (0.2μA typical)
 - Ideally suited for notebook applications
- Packaging (Pb-free & Green available):
 - 24-pin 173-mil wide plastic TSSOP (L)
 - 24-pin 150-mil wide plastic QSOP (Q)
 - 24-pin 300-mil wide plastic SOIC (S)

Description

The PI5C3383 is a 5-bit, 4-port bus switch with exchange designed with a low On-Resistance allowing inputs to be connected directly to outputs. The switch creates no additional propagational delay or additional ground bounce noise. The switch is turned ON by the Bus Enable (\overline{BE}) input signal, and the Bus Exchange (BX) input signal offers nibble swapping of the AB and CD pairs of signals. This exchange configuration allows byte swapping of buses in systems. It can also be used as a quad 2-to-1 multiplexer and to create low delay barrel shifters, etc.

Block Diagram

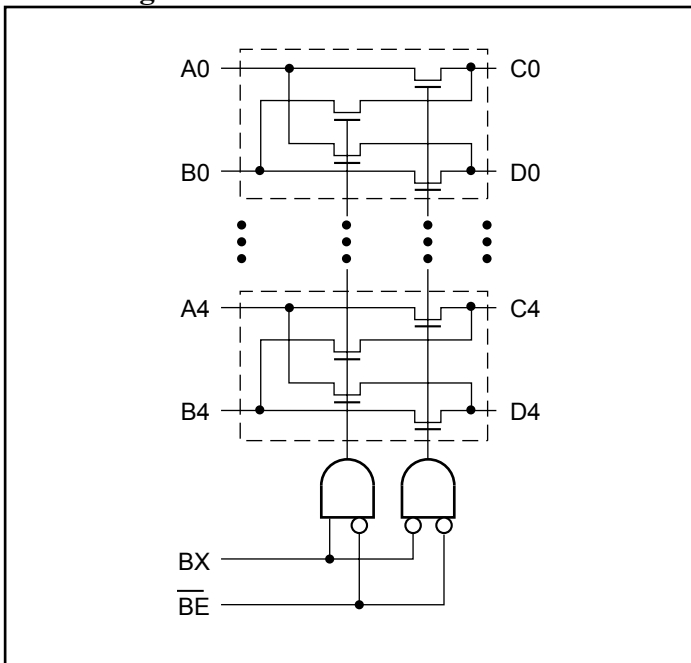

Pin Configuration

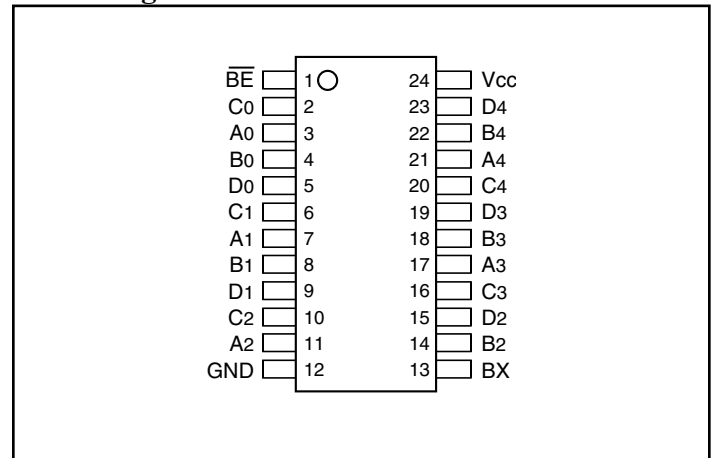

Truth Table⁽¹⁾

Function	\overline{BE}	BX	A0-A4	B0-B4
Disconnect	H	X	Hi-Z	Hi-Z
Connect	L	L	C0-C4	D0-D4
Exchange	L	H	D0-D4	C0-C4

Note:

1. H = High Voltage Level, X = Don't Care
L = Low Voltage Level, Hi-Z = High Impedance

Pin Description

Pin Name	Description
\overline{BE}	Bus Enable Input (Active LOW)
B _X	Bus Exchange Input
A _X	Bus A
B _X	Bus B
C _X	Bus C
D _X	Bus D
GND	Ground
V _{CC}	Power

Maximum Ratings

(Above which the useful life may be impaired. For user guidelines, not tested.)

Storage Temperature	-65°C to +150°C
Ambient Temperature with Power Applied	-40°C to +85°C
Supply Voltage to Ground Potential (Inputs & V _{CC} Only)...	-0.5V to +7.0V
Supply Voltage to Ground Potential (Outputs & D/O Only)	-0.5V to +7.0V
DC Input Voltage	-0.5V to +7.0V
DC Output Current.....	120 mA
Power Dissipation	0.5W

Note:

Stresses greater than those listed under MAXIMUM RATINGS may cause permanent damage to the device. This is a stress rating only and functional operation of the device at these or any other conditions above those indicated in the operational sections of this specification is not implied. Exposure to absolute maximum rating conditions for extended periods may affect reliability.

DC Electrical Characteristics (Over the Operating Range, T_A = -40°C to +85°C, V_{CC} = 5V ±5%)

Parameters	Description	Test Conditions ⁽¹⁾	Min.	Typ. ⁽²⁾	Max	Units
V _{IH}	Input HIGH Voltage	Guaranteed Logic HIGH Level	2.0	-	-	V
V _{IL}	Input LOW Voltage	Guaranteed Logic LOW Level	-0.5	-	0.8	
I _{IH}	Input HIGH Current	V _{CC} = Max., V _{IN} = V _{CC}	-	-	±1	μA
I _{IL}	Input LOW Current	V _{CC} = Max., V _{IN} = GND	-	-	±1	
I _{OZH}	High Impedance Output Current	0 ≤ A B, CD ≤ V _{CC}	-	-	±1	
V _{IK} V	Clamp Diode Voltage	V _{CC} = Min., I _{IN} = -18mA		-	-0.7	-1.2
I _{OS}	Short Circuit Current ⁽³⁾	AB (CD) = 0V, CD (AB) = V _{CC}	100	-	-	mA
V _H	Input Hysteresis at Control Pins		-	150	-	mV
R _{ON}	Switch On-Resistance ⁽⁴⁾	V _{CC} = Min., V _{IN} = 0.0V, I _{ON} = 48mA	-	5	7	Ω
		V _{CC} = Min., V _{IN} = 2.4V, I _{ON} = 15mA	-	10	15	

Capacitance (T_A = 25°C, f = 1 MHz)

Parameters ⁽⁵⁾	Description	Test Conditions	Typ.	Units
C _{IN}	Input Capacitance	V _{IN} = 0V	6	pF
C _{OFF}	AB/CD Capacitance, Switch OFF		8	
C _{ON}	AB/CD Capacitance, Switch ON		14	

Notes:

- For Max. or Min. conditions, use appropriate value specified under Electrical Characteristics for the applicable device type.
- Typical values are at V_{CC} = 5.0V, T_A = 25°C ambient and maximum loading.
- Not more than one output should be shorted at one time. Duration of the test should not exceed one second.
- Measured by the voltage drop between AB and CD pin at indicated current through the switch. On-Resistance is determined by the lower of the voltages on the two (A or B, C or D) pins.
- This parameter is determined by device characterization but is not production tested.

Power Supply Characteristics

Parameters	Description	Test Conditions ⁽¹⁾		Min.	Typ.	Max.	Units
I _{CC}	Quiescent Power Supply Current	V _{CC} = Max.	V _{IN} = GND or V _{CC}	-	0.1	3.0	μA
ΔI _{CC}	Supply Current per Input @ TTL HIGH	V _{CC} = Max.	V _{IN} = 3.4V ⁽³⁾	-	-	2.5	mA
I _{CCD}	Supply Current per Input per MHz ⁽⁴⁾	V _{CC} = Max., AB and CD pins Open BE = GND Control Input Toggling 50% Duty Cycle		-	-	0.25	mA/ MHz

Notes:

1. For Max. or Min. conditions, use appropriate value specified under Electrical Characteristics for the applicable device.
2. Typical values are at V_{CC} = 5.0V, +25°C ambient.
3. Per TTL driven input (V_{IN} = 3.4V, control inputs only); A, B, C, and D pins do not contribute to I_{CC}.
4. This current applies to the control inputs only and represent the current required to switch internal capacitance at the specified frequency. The A, B, C, and D inputs generate no significant AC or DC currents as they transition. This parameter is not tested, but is guaranteed by design.

Switching Characteristics over Operating Range

Parameters	Description	Conditions ⁽¹⁾	Com			Units
			Min.	Typ.	Max	
t _{PLH} t _{PHL}	Propagation Delay ^(2, 3) Ax to Cx, Bx to Dx	C _L = 50pF R _L = 500Ω	-	0.25	-	ns
t _{PZH} t _{PZL}	Bus Enable Time \overline{BE} to Cx or Dx		1.5	-	6.5	
t _{PHZ} t _{PLZ}	Bus Disable Time \overline{BE} to Cx or Dx		1.5	-	5.5	
t _{BX}	Bus Exchange Time BX to Cx or Dx		1.5	-	6.5	

Notes:

1. See test circuit and waveforms.
2. This parameter is guaranteed but not tested on Propagation Delays.
3. The bus switch contributes no propagational delay other than the RC delay of the On-Resistance of the switch and the load capacitance. The time constant for the switch alone is of the order of 0.25ns for 50pF load. Since this time constant is much smaller than the rise/fall times of typical driving signals, it adds very little propagational delay to the system. Propagational delay of the bus switch when used in a system is determined by the driving circuit on the driving side of the switch and its interaction with the load on the driven side.

Applications

Logic Inputs

The logic control inputs can be driven up to +5.5V regardless of the supply voltage. For example, given a 5.0V supply, the control or select pins may be driven low to 0V and high to 5.5V. Driving the control or select pins Rail-toRail minimizes power consumption.

Power-Supply Sequencing

Proper power-supply sequencing is recommended for all CMOS devices. Always apply V_{CC} before applying signals to the input/output or control pins.

Packaging Mechanical: 24-Pin TSSOP (L)

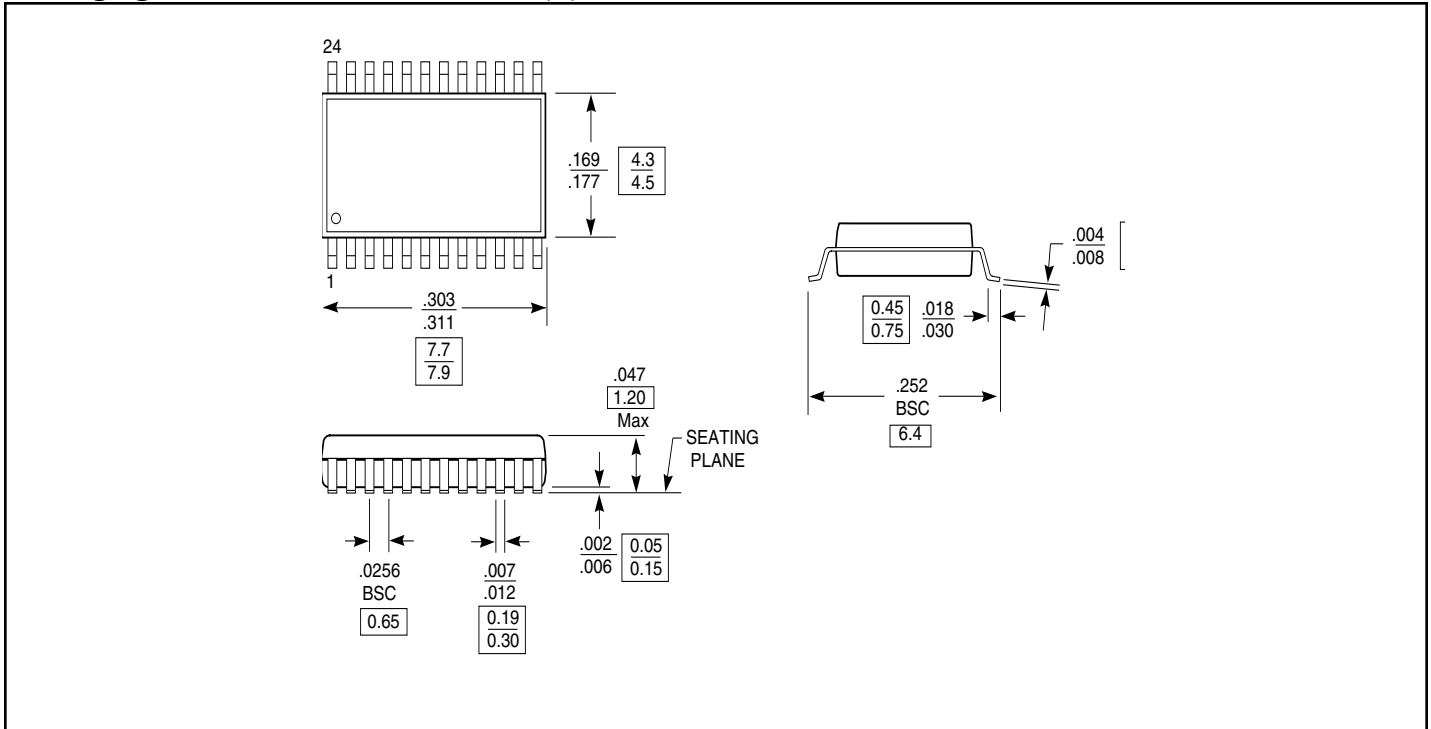

Packaging Mechanical: 24-Pin QSOP (Q)

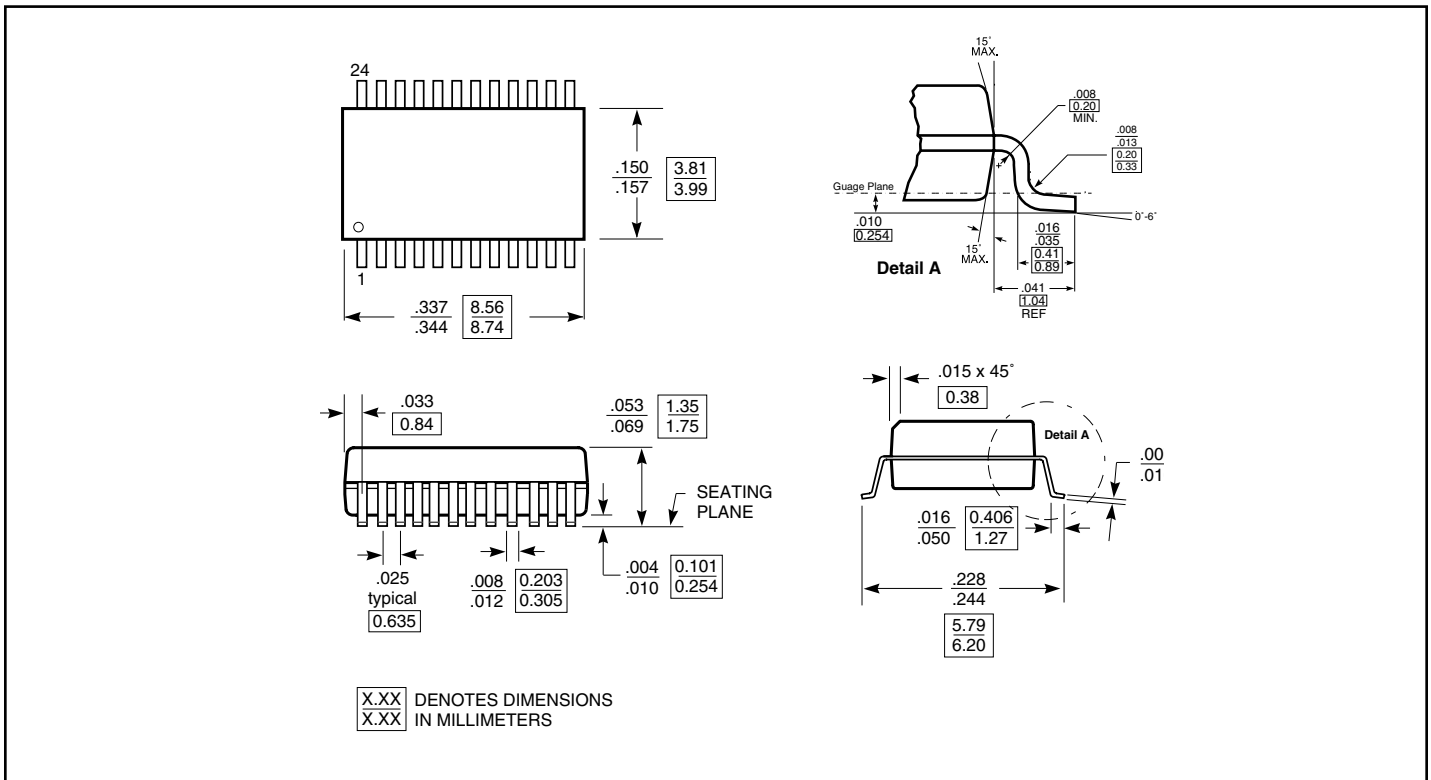

X.XX DENOTES DIMENSIONS
X.XX IN MILLIMETERS

Packaging Mechanical: 24-Pin SOIC (S)

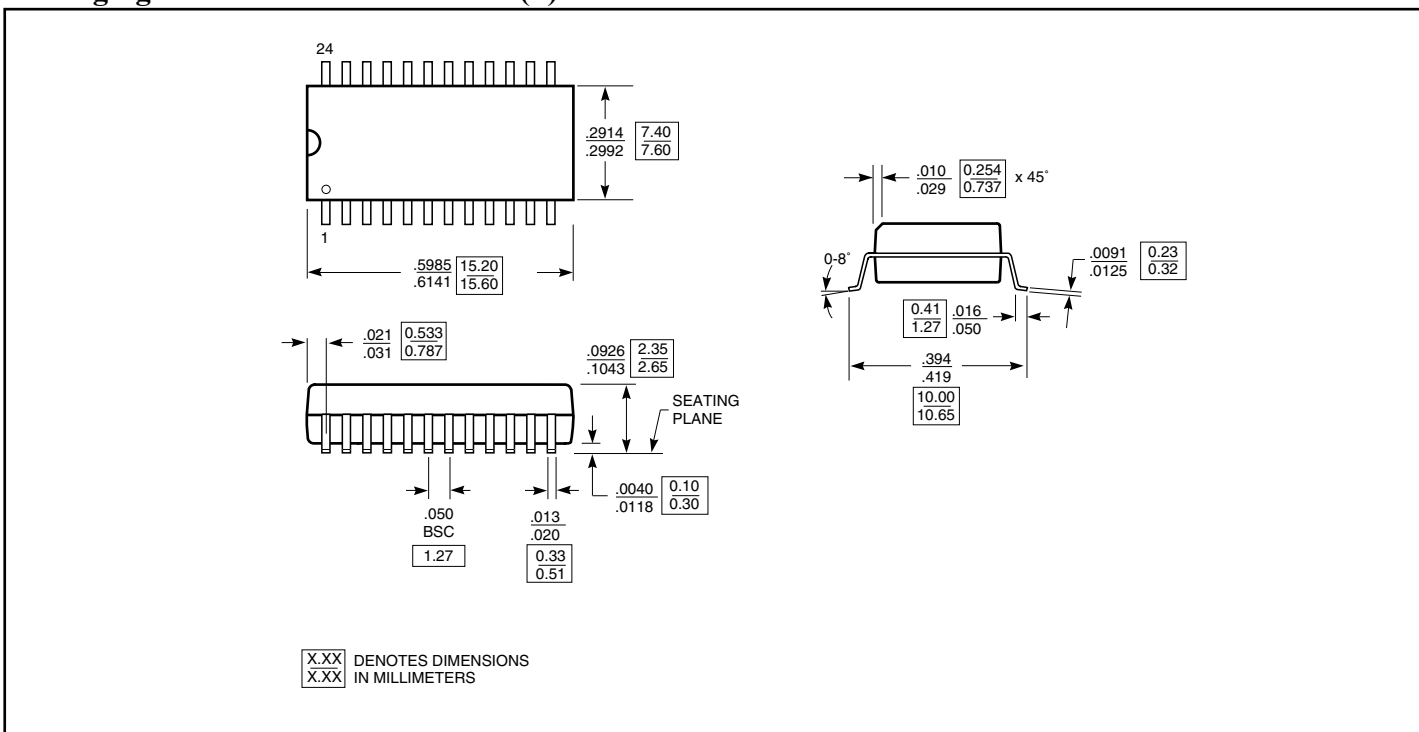

Ordering Information

Ordering Code	Packaging Code	Package Type
PI5C3383L	L	24-pin 173-mil wide plastic TSSOP
PI5C3383LE	L	Pb-free & Green, 24-pin 173-mil wide plastic TSSOP
PI5C3383Q	Q	24-pin 150-mil wide plastic QSOP
PI5C3383QE	Q	Pb-free & Green, 24-pin 150-mil wide plastic QSOP
PI5C3383S	S	24-pin 300-mil wide plastic SOIC
PI5C3383SE	S	Pb-free & Green, 24-pin 300-mil wide plastic SOIC

Notes:

1. Thermal characteristics can be found on the company web site at www.pericom.com/packaging/