

General Description

The MIC5891 latched driver is a high-voltage, high current integrated circuit comprised of eight CMOS data latches, CMOS control circuitry for the common STROBE and OUTPUT ENABLE, and bipolar Darlington transistor drivers for each latch.

Bipolar/MOS construction provides extremely low power latches with maximum interface flexibility.

The MIC5891 will typically operate at 5MHz with a 5V logic supply.

The CMOS inputs are compatible with standard CMOS, PMOS, and NMOS logic levels. TTL circuits may be used with appropriate pull-up resistors to ensure a proper logic-high input.

A CMOS serial data output allows additional drivers to be cascaded when more than 8 bits are required.

The MIC5891 has open-emitter outputs with suppression diodes for protection against inductive load transients. The output transistors are capable of sourcing 500mA and will sustain at least 35V in the on-state.

Simultaneous operation of all drivers at maximum rated current requires a reduction in duty cycle due to package power limitations. Outputs may be paralleled for higher load current capability.

The MIC5891 is available in a 16-pin plastic DIP package (N) and 16-pin wide SOIC package (WM).

Features

- High-voltage, high-current outputs
- Output transient protection diodes
- CMOS-, PMOS-, NMOS-, and TTL-compatible inputs
- 5MHz typical data input rate
- Low-power CMOS latches

Applications

- Alphanumeric and bar graph displays
- LED and incandescent displays
- Relay and solenoid drivers
- Other high-power loads

Ordering Information

Part Number	Temperature Range	Package
MIC5891BN	-40°C to +85°C	16-Pin Plastic DIP
MIC5891BWM	-40°C to +85°C	16-pin Wide SOIC

Functional Diagram

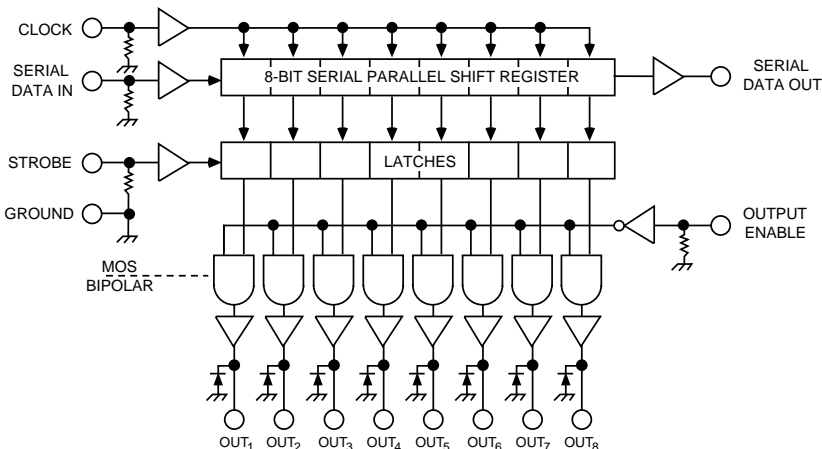

Pin Configurations

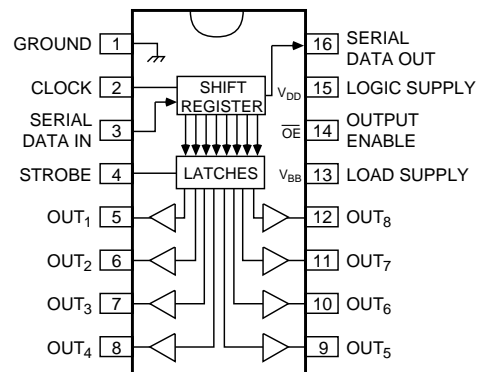

Typical Circuits

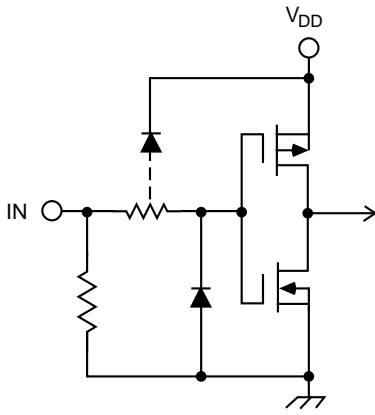

Typical Input Circuit

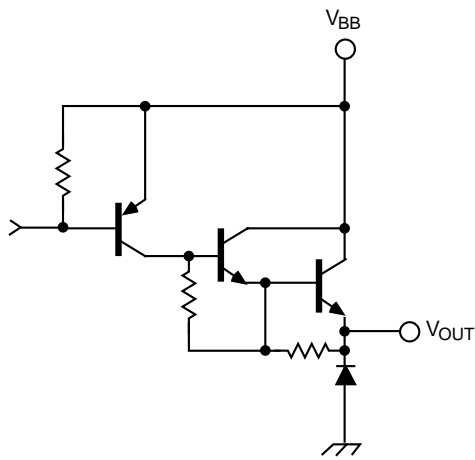

Typical Output Circuit

Absolute Maximum Ratings (Notes 1, 2, 3)

- Output Voltage (V_{OUT}) 50V
- Logic Supply Voltage Range (V_{DD}) 4.5V to 15V
- Load Supply Voltage Range (V_{BB}) 5.0V to 50V
- Input Voltage Range (V_{IN}) $-0.3V$ to $V_{DD}+0.3V$
- Continuous Collector Current (I_C) 500mA
- Package Power Dissipation *see graph*
- Operating Temperature Range (T_A) $-55^{\circ}C$ to $+125^{\circ}C$
- Storage Temperature Range (T_S) $-65^{\circ}C$ to $+150^{\circ}C$

Note 1: $T_A = 25^{\circ}C$

Note 2: Derate at the rate of 20mW/ $^{\circ}C$ above $T_A = 25^{\circ}C$.

Note 3: Micrel CMOS devices have input-static protection but are susceptible to damage when exposed to extremely high static electrical charges.

Allowable Duty Cycles

Number of Outputs ON at $I_{OUT} = -200\text{ mA}$	Max. Allowable Duty Cycles at T_A of:		
	50°C	60°C	70°C
8	53%	47%	41%
7	60%	54%	48%
6	70%	64%	56%
5	83%	75%	67%
4	100%	94%	84%
3	100%	100%	100%
2	100%	100%	100%
1	100%	100%	100%

Allowable Package Power Dissipation vs. Temp.

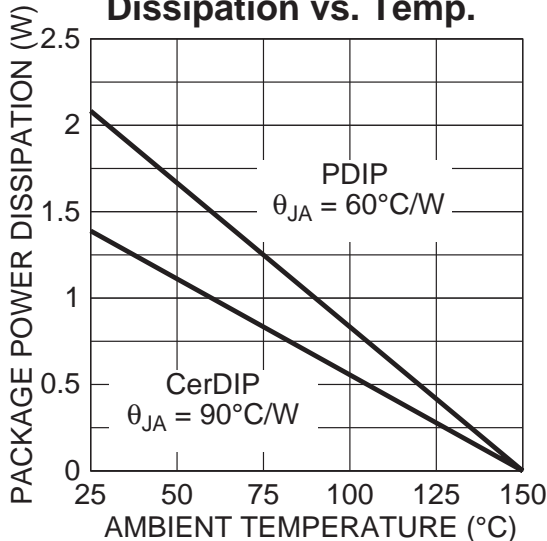

Electrical Characteristics

$V_{BB} = 50V$, $V_{DD} = 5V$ to $12V$; $T_A = +25^\circ C$; unless noted.

Characteristic	Symbol	V_{BB}	Test Conditions	Limits		
				Min.	Max.	Units
Output Leakage Current	I_{CEX}	50V	$T_A = +25^\circ C$		-50	μA
			$T_A = +85^\circ C$		-100	μA
Output Saturation Voltage	$V_{CE(SAT)}$	50V	$I_{OUT} = -100mA$, $T_A = +85^\circ C$		1.8	V
			$I_{OUT} = -225mA$, $T_A = +85^\circ C$		1.9	V
			$I_{OUT} = -350mA$, $T_A = +85^\circ C$		2.0	V
Output Sustaining Voltage	$V_{CE(SUS)}$	50V	$I_{OUT} = -350mA$, $L = 2mH$	35		V
Input Voltage	$V_{IN(1)}$	50V	$V_{DD} = 5.0V$	3.5	$V_{DD}+0.3$	V
			$V_{DD} = 12V$	10.5	$V_{DD}+0.3$	V
	$V_{IN(0)}$	50V	$V_{DD} = 5V$ to $12V$	$V_{SS}-0.3$	0.8	V
Input Current	$I_{IN(1)}$	50V	$V_{DD} = V_{IN} = 5.0V$		50	μA
			$V_{DD} = 12V$		240	μA
Input Impedance	Z_{IN}	50V	$V_{DD} = 5.0V$	100		$k\Omega$
			$V_{DD} = 12V$	50		$k\Omega$
Maximum Clock Frequency	f_c	50V		3.3		MHz
Serial Data Output Resistance	R_{OUT}	50V	$V_{DD} = 5.0V$		20	$k\Omega$
			$V_{DD} = 12V$		6.0	$k\Omega$
Turn-On Delay	t_{PLH}	50V	Output Enable to Output, $I_{OUT} = -350mA$		2.0	μs
Turnoff Delay	t_{PHL}	50V	Output Enable to Output, $I_{OUT} = -350mA$		10	μs
Supply Current	I_{BB}	50V	all outputs on, all outputs open		10	mA
			all outputs off		200	μA
	I_{DD}	50V	$V_{DD} = 5V$, all outputs off, inputs = 0V		100	μA
			$V_{DD} = 12V$, all outputs off, inputs = 0V		200	μA
			$V_{DD} = 5V$, one output on, all inputs = 0V		1.0	mA
$V_{DD} = 12V$, one output on, all inputs = 0V		3.0	mA			
Diode Leakage Current	I_H	Max	$T_A = +25^\circ C$		50	μA
			$T_A = +85^\circ C$		100	μA
Diode Forward Voltage	V_F	Open	$I_F = 350mA$		2.0	V

Note 4: Positive (negative) current is defined as going into (coming out of) the specified device pin.

Note 5: Operation of these devices with standard TTL may require the use of appropriate pull-up resistors.

Timing Conditions

($V_{DD} = 5.0V$, Logic Levels are V_{DD} and Ground)

- A. Minimum data active time before clock pulse (data set-up time) 75ns
- B. Minimum data active time after clock pulse (data hold time) 75ns
- C. Minimum data pulse width 150ns
- D. Minimum clock pulse width 150ns
- E. Minimum time between clock activation and strobe 300ns
- F. Minimum strobe pulse width 100ns
- G. Typical time between strobe activation and output transition 1.0 μs
- H. Turnoff delay see Electrical Characteristics
- I. Turn-on delay see Electrical Characteristics

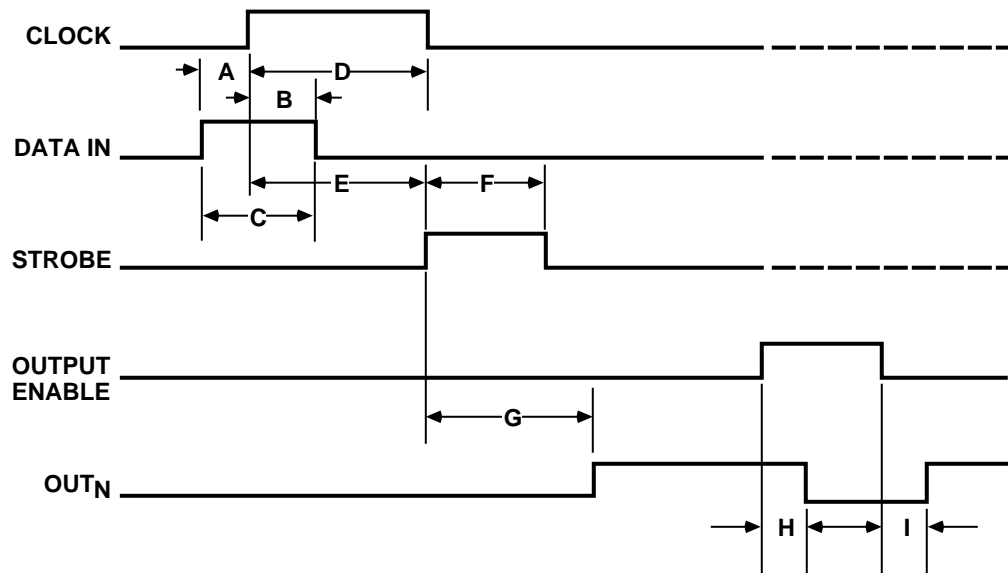

Timing Conditions

Truth Table

Serial Data Input	Clock Input	Shift Register Contents						Serial Data Output	Strobe Input	Latch Contents						Output Enable	Output Content					
		I ₁	I ₂	I ₃	...	I _{N-1}	I _N			I ₁	I ₂	I ₃	...	I _{N-1}	I _N		I ₁	I ₂	I ₃	...	I _{N-1}	I _N
H	⌋	H	R ₁	R ₂	...	R _{N-2}	R _{N-1}	R _{N-1}														
L	⌋	L	R ₁	R ₂	...	R _{N-2}	R _{N-1}	R _{N-1}														
X	⌋	R ₁	R ₂	R ₃	...	R _{N-1}	R _N	R _N														
		X	X	X	...	X	X	X	L	R ₁	R ₂	R ₃	...	R _{N-1}	R _N							
		P ₁	P ₂	P ₃	...	P _{N-1}	P _N	P _N	H	P ₁	P ₂	P ₃	...	P _{N-1}	P _N	L						
										X	X	X	...	X	X	H	L	L	L	...	L	L

L = Low Logic Level
 H = High Logic Level
 X = Irrelevant
 P = Present State
 R = Previous State

Applications Information

Serial data present at the input is transferred into the shift register on the rising edge of the CLOCK input pulse. Additional CLOCK pulses shift data information towards the SERIAL DATA OUTPUT. The serial data must appear at the input prior to the rising edge of the CLOCK input waveform.

The 8 bits present in the shift register are transferred to the respective latches when the STROBE is high (serial-to-parallel conversion). The latches will continue to accept new

data as long as the STROBE is held high. Most applications where the latching feature is not used (STROBE tied high) require the OUTPUT ENABLE input to be high during serial data entry.

Outputs are active (controlled by the latch state) when the OUTPUT ENABLE is low. All Outputs are low (disabled) when the OUTPUT ENABLE is high. OUTPUT ENABLE does not affect the data in the shift register or latch.