



# Low-Power, Single-/Dual-Level Battery Monitors with Hysteresis and Integrated $\mu$ P Reset

**MAX6439-MAX6442**

## General Description

The MAX6439–MAX6442 are a family of ultra-low-power battery monitors with integrated microprocessor ( $\mu$ P) supervisors. The battery monitors are offered with single or dual low-battery output options that can be used to signal when the battery is OK (enabling full system operation), when the battery is low (for low-power system operation), and when the battery is dead (to disable system operation). These devices also have an independent  $\mu$ P supervisor that monitors  $V_{CC}$  and provides an active-low reset output. A manual reset function is available to reset the  $\mu$ P with a push-button. No external components are required.

The MAX6439–MAX6442 are offered with several factory-trimmed low-battery threshold combinations ideal for single-cell lithium-ion (Li+) or multicell alkaline/NiCd/NiMH applications. When the battery voltage drops below each specified low threshold, the low-battery outputs are asserted to alert the system. When the voltage rises above the specified high thresholds, the outputs are deasserted after a 150ms minimum timeout period, ensuring the voltages have stabilized before power circuitry is activated or providing microprocessor reset timing. The low and high thresholds provide hysteresis in battery-operated systems to eliminate output chattering.

The MAX6439/MAX6440 offer factory-trimmed battery monitors with a single output. The MAX6441/MAX6442 offer factory-trimmed battery monitors with dual outputs. All battery monitors have open-drain low-battery outputs.

The MAX6439–MAX6442 monitor system voltages ( $V_{CC}$ ) from 1.8V to 3.3V with seven fixed reset threshold options. Each device is offered with two minimum reset timeout periods of 150ms or 1200ms. The MAX6439/MAX6441 are offered with an open-drain  $\overline{\text{RESET}}$  output and the MAX6440/MAX6442 are offered with a push-pull  $\overline{\text{RESET}}$  output.

The MAX6439–MAX6442 are offered in a SOT23 package and are fully specified over a  $-40^{\circ}\text{C}$  to  $+85^{\circ}\text{C}$  temperature range.

## Applications

- Battery-Powered Systems (Single-Cell Li+ or Two-/Three-Cell NiMH, NiCd, Alkaline)
- Cell Phones/Cordless Phones
- Portable Medical Devices
- Electronic Toys
- Pagers
- PDAs
- MP3 Players

## Features

- ◆ Factory-Trimmed  $V_{\text{BATT}}$  Threshold Options for Monitoring Single-Cell Li+ or Multicell Alkaline/NiCd/NiMH Applications
- ◆ Immune to Short Battery Voltage Transients
- ◆ Low Current (2.5 $\mu$ A typ at 3.6V)
- ◆ Single and Dual Low-Battery Output Options
- ◆ 150ms Minimum  $\overline{\text{LBO}}$  Timeout Period
- ◆ Independent  $\mu$ P Reset with Manual Reset
- ◆ Factory-Set Reset Thresholds for Monitoring  $V_{CC}$  from 1.8V to 3.3V
- ◆ Available with 150ms (min) and 1.2s (min)  $V_{CC}$  Reset Timeout Period Options
- ◆  $-40^{\circ}\text{C}$  to  $+85^{\circ}\text{C}$  Operating Temperature Range
- ◆ Small 6- and 8-Pin SOT23 Packages
- ◆ No External Components

## Ordering Information

PART	TEMP RANGE	PIN-PACKAGE
MAX6439UT__ _D_-T	$-40^{\circ}\text{C}$ to $+85^{\circ}\text{C}$	6 SOT23-6
MAX6440UT__ _D_-T	$-40^{\circ}\text{C}$ to $+85^{\circ}\text{C}$	6 SOT23-6
MAX6441KA__ _D_-T	$-40^{\circ}\text{C}$ to $+85^{\circ}\text{C}$	8 SOT23-8
MAX6442KA__ _D_-T	$-40^{\circ}\text{C}$ to $+85^{\circ}\text{C}$	8 SOT23-8

**Note:** The first two “\_” are placeholders for the battery monitor voltage levels. Desired threshold levels are set by the part number suffix found in Tables 1 and 2. The third “\_” is the  $V_{CC}$  reset threshold level suffix found in Table 3. The “\_” after the D is a placeholder for the reset timeout period suffix found in Table 4. All devices are available in tape-and-reel only. There is a 2500-piece minimum order increment for standard versions. Sample stock is typically held on standard versions only. Nonstandard versions require a minimum order increment of 10,000 pieces. Contact factory for availability.

## Pin Configurations

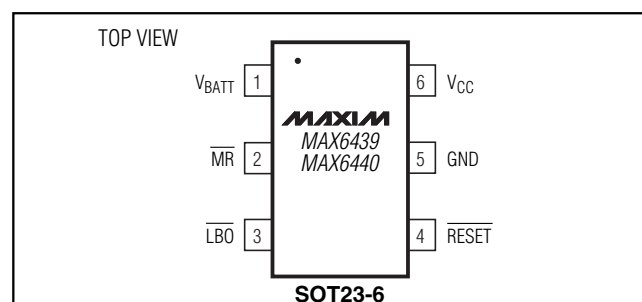

Pin Configurations continued at end of data sheet.



# Low-Power, Single-/Dual-Level Battery Monitors with Hysteresis and Integrated $\mu$ P Reset

## ABSOLUTE MAXIMUM RATINGS

$V_{BATT}$ , $V_{CC}$ to GND.....	-0.3V to +6V*
Open-Drain $\overline{LBO}$ , $\overline{LBOH}$ , $\overline{LBOL}$ , $\overline{LBOLH}$ to GND ...	-0.3V to +6V*
Open-Drain $\overline{RESET}$ to GND .....	-0.3V to +6V*
Push-Pull $\overline{RESET}$ to GND.....	-0.3V to ( $V_{CC} + 0.3V$ )
$\overline{MR}$ to GND .....	-0.3V to ( $V_{CC} + 0.3V$ )
Input/Output Current, All Pins .....	20mA
Continuous Power Dissipation ( $T_A = +70^\circ\text{C}$ )	
6-Pin SOT23 (derate 8.7mW/ $^\circ\text{C}$ above +70 $^\circ\text{C}$ ).....	695mW
8-Pin SOT23 (derate 8.9mW/ $^\circ\text{C}$ above +70 $^\circ\text{C}$ ).....	714mW

Operating Temperature Range .....	-40 $^\circ\text{C}$ to +85 $^\circ\text{C}$
Junction Temperature .....	+150 $^\circ\text{C}$
Storage Temperature Range .....	-65 $^\circ\text{C}$ to +150 $^\circ\text{C}$
Lead Temperature (soldering, 10s) .....	+300 $^\circ\text{C}$

\*Applying 7V for a duration of 1ms does not damage the device.

Stresses beyond those listed under "Absolute Maximum Ratings" may cause permanent damage to the device. These are stress ratings only, and functional operation of the device at these or any other conditions beyond those indicated in the operational sections of the specifications is not implied. Exposure to absolute maximum rating conditions for extended periods may affect device reliability.

## ELECTRICAL CHARACTERISTICS

( $V_{BATT} = 1.2V$  to 5.5V,  $V_{CC} = 1.2V$  to 5.5V,  $T_A = -40^\circ\text{C}$  to +85 $^\circ\text{C}$ , unless otherwise specified. Typical values are at  $T_A = +25^\circ\text{C}$ .) (Note1)

PARAMETER	SYMBOL	CONDITIONS	MIN	TYP	MAX	UNITS
$V_{BATT}$ Operating Voltage Range	$V_{BATT}$	$T_A = 0^\circ\text{C}$ to +85 $^\circ\text{C}$	1.0		5.5	V
		$T_A = -40^\circ\text{C}$ to +85 $^\circ\text{C}$	1.2		5.5	
$V_{CC}$ Operating Voltage Range	$V_{CC}$	$T_A = 0^\circ\text{C}$ to +85 $^\circ\text{C}$	1.0		5.5	V
		$T_A = -40^\circ\text{C}$ to +85 $^\circ\text{C}$	1.2		5.5	
$V_{CC} + V_{BATT}$ Supply Current	$I_{CC} + I_{BATT}$	$V_{BATT} = 3.6V$ , $V_{CC} = 3.3V$ , no load (Note 2)		2.5	7	$\mu\text{A}$
<b><math>V_{BATT}</math> THRESHOLDS</b>						
HTH Threshold	HTH	MAX6439UT_J, MAX6440UT_J	3.510	3.60	3.690	V
		MAX6439UT_I, MAX6440UT_I	3.413	3.50	3.588	
		MAX6439UT_H, MAX6440UT_H	3.315	3.40	3.485	
		MAX6439UT_G, MAX6440UT_G	3.218	3.30	3.383	
		MAX6439UT_T, MAX6440UT_T	2.535	2.60	2.665	
		MAX6439UT_S, MAX6440UT_S	2.438	2.50	2.563	
		MAX6439UT_R, MAX6440UT_R	2.340	2.40	2.460	
LTH Threshold	LTH	MAX6439UTF, MAX6440UTF	3.023	3.10	3.178	V
		MAX6439UTE, MAX6440UTE	2.925	3.00	3.075	
		MAX6439UTD, MAX6440UTD	2.828	2.90	2.973	
		MAX6439UTC, MAX6440UTC	2.730	2.80	2.870	
		MAX6439UTB, MAX6440UTB	2.633	2.70	2.768	
		MAX6439UTA, MAX6440UTA	2.535	2.60	2.665	
		MAX6439UTP, MAX6440UTP	2.048	2.10	2.153	
		MAX6439UTO, MAX6440UTO	1.950	2.00	2.050	
		MAX6439UTN, MAX6440UTN	1.853	1.90	1.948	
		MAX6439UTM, MAX6440UTM	1.755	1.80	1.845	
		MAX6439UTL, MAX6440UTL	1.658	1.70	1.743	
		MAX6439UTK, MAX6440UTK	1.560	1.60	1.640	

# Low-Power, Single-/Dual-Level Battery Monitors with Hysteresis and Integrated $\mu$ P Reset

**MAX6439-MAX6442**

## ELECTRICAL CHARACTERISTICS (continued)

( $V_{BATT} = 1.2V$  to  $5.5V$ ,  $V_{CC} = 1.2V$  to  $5.5V$ ,  $T_A = -40^\circ C$  to  $+85^\circ C$ , unless otherwise specified. Typical values are at  $T_A = +25^\circ C$ .) (Note1)

PARAMETER	SYMBOL	CONDITIONS	MIN	TYP	MAX	UNITS
HTH- Threshold	HTH-	MAX6441UT_J, MAX6442UT_J	3.510	3.600	3.690	V
		MAX6441UT_I, MAX6442UT_I	3.413	3.500	3.588	
		MAX6441UT_H, MAX6442UT_H	3.315	3.400	3.485	
		MAX6441UT_G, MAX6442UT_G	3.218	3.300	3.383	
		MAX6441UT_T, MAX6442UT_T	2.535	2.600	2.665	
		MAX6441UT_S, MAX6442UT_S	2.438	2.500	2.563	
		MAX6441UT_R, MAX6442UT_R	2.340	2.400	2.460	
		MAX6441UT_Q, MAX6442UT_Q	2.243	2.300	2.358	
HTH+ Threshold	HTH+	MAX6441UT_J, MAX6442UT_J	3.686	3.780	3.875	V
		MAX6441UT_I, MAX6442UT_I	3.583	3.675	3.767	
		MAX6441UT_H, MAX6442UT_H	3.481	3.570	3.659	
		MAX6441UT_G, MAX6442UT_G	3.378	3.465	3.552	
		MAX6441UT_T, MAX6442UT_T	2.662	2.730	2.798	
		MAX6441UT_S, MAX6442UT_S	2.559	2.625	2.691	
		MAX6441UT_R, MAX6442UT_R	2.457	2.520	2.583	
		MAX6441UT_Q, MAX6442UT_Q	2.355	2.415	2.476	
LTH- Threshold	LTH-	MAX6441UTF, MAX6442UTF	3.023	3.100	3.178	V
		MAX6441UTE, MAX6442UTE	2.925	3.000	3.075	
		MAX6441UTD, MAX6442UTD	2.828	2.900	2.973	
		MAX6441UTC, MAX6442UTC	2.730	2.800	2.870	
		MAX6441UTB, MAX6442UTB	2.633	2.700	2.768	
		MAX6441UTA, MAX6442UTA	2.535	2.600	2.665	
		MAX6441UTP, MAX6442UTP	2.048	2.100	2.153	
		MAX6441UTO, MAX6442UTO	1.950	2.000	2.050	
		MAX6441UTN, MAX6442UTN	1.853	1.900	1.948	
		MAX6441UTM, MAX6442UTM	1.755	1.800	1.845	
		MAX6441UTL, MAX6442UTL	1.658	1.700	1.743	
		MAX6441UTK, MAX6442UTK	1.560	1.600	1.640	
LTH+ Threshold	LTH+	MAX6441UTF, MAX6442UTF	3.174	3.255	3.337	V
		MAX6441UTE, MAX6442UTE	3.071	3.150	3.229	
		MAX6441UTD, MAX6442UTD	2.969	3.045	3.121	
		MAX6441UTC, MAX6442UTC	2.867	2.940	3.014	
		MAX6441UTB, MAX6442UTB	2.764	2.835	2.906	
		MAX6441UTA, MAX6442UTA	2.662	2.730	2.798	
		MAX6441UTP, MAX6442UTP	2.150	2.205	2.260	
		MAX6441UTO, MAX6442UTO	2.048	2.100	2.153	
		MAX6441UTN, MAX6442UTN	1.945	1.995	2.045	
		MAX6441UTM, MAX6442UTM	1.843	1.890	1.937	
		MAX6441UTL, MAX6442UTL	1.740	1.785	1.830	
		MAX6441UTK, MAX6442UTK	1.638	1.680	1.722	

# Low-Power, Single-/Dual-Level Battery Monitors with Hysteresis and Integrated $\mu$ P Reset

## ELECTRICAL CHARACTERISTICS (continued)

( $V_{BATT} = 1.2V$  to  $5.5V$ ,  $V_{CC} = 1.2V$  to  $5.5V$ ,  $T_A = -40^\circ C$  to  $+85^\circ C$ , unless otherwise specified. Typical values are at  $T_A = +25^\circ C$ .) (Note 1)

PARAMETER	SYMBOL	CONDITIONS	MIN	TYP	MAX	UNITS
$\overline{LBO}$ , $\overline{LBOL}$ , $\overline{LBOH}$ , $\overline{LBOLH}$ Timeout Period	$t_{LBOP}$	$V_{BATT}$ rising above threshold	150	225	300	ms
$\overline{LBO}$ , $\overline{LBOL}$ , $\overline{LBOH}$ , $\overline{LBOLH}$ Delay Time	$t_{LBOD}$	$V_{BATT}$ falling below threshold		100		$\mu s$
$\overline{LBO}$ , $\overline{LBOL}$ , $\overline{LBOH}$ , $\overline{LBOLH}$ Output Low (Open Drain)	$V_{OL}$	( $V_{BATT}$ or $V_{CC}$ ) $\geq 1.2V$ , $I_{SINK} = 50\mu A$ , asserted low			0.3	V
		( $V_{BATT}$ or $V_{CC}$ ) $\geq 1.6V$ , $I_{SINK} = 100\mu A$ , asserted low			0.3	
		( $V_{BATT}$ or $V_{CC}$ ) $\geq 2.7V$ , $I_{SINK} = 1.2mA$ , asserted low			0.3	
		( $V_{BATT}$ or $V_{CC}$ ) $\geq 4.5V$ , $I_{SINK} = 3.2mA$ , asserted low			0.3	
$\overline{LBO}$ , $\overline{LBOL}$ , $\overline{LBOH}$ , $\overline{LBOLH}$ Output Open-Drain Leakage Current	$I_{LKG}$	Output deasserted			500	nA
$V_{CC}$ Reset Threshold	$V_{TH}$	MAX64_-----T	3.000	3.075	3.150	V
		MAX64_-----S	2.850	2.925	3.000	
		MAX64_-----R	2.550	2.625	2.700	
		MAX64_-----Z	2.250	2.313	2.375	
		MAX64_-----Y	2.125	2.188	2.250	
		MAX64_-----W	1.620	1.665	1.710	
		MAX64_-----V	1.530	1.575	1.620	
$V_{CC}$ Reset Hysteresis				0.3		%
$V_{CC}$ to $\overline{RESET}$ Delay		$V_{CC}$ falling at $10mV/\mu s$ from ( $V_{TH} + 100mV$ ) to ( $V_{TH} - 100mV$ )		50		$\mu s$
$V_{CC}$ to $\overline{RESET}$ Timeout Period	$t_{RP}$	MAX64_-----D3	150	225	300	ms
		MAX64_-----D7	1200	1800	2400	
$\overline{MR}$ Input Voltage	$V_{IL}$			$0.3 \times V_{CC}$		V
	$V_{IH}$		$0.7 \times V_{CC}$			
$\overline{MR}$ Minimum Pulse Width	$t_{MPW}$		1			$\mu s$
$\overline{MR}$ Glitch Rejection				100		ns
$\overline{MR}$ to $\overline{RESET}$ Delay				200		ns
$\overline{MR}$ Reset Timeout Period	$t_{MRP}$		150	225	300	ms
$\overline{MR}$ Pullup Resistance		$\overline{MR}$ to $V_{CC}$	750	1500	2250	$\Omega$
$\overline{MR}$ Rising Debounce Period	$t_{DEB}$	(Note 3)	150	225	300	ms

# Low-Power, Single-/Dual-Level Battery Monitors with Hysteresis and Integrated $\mu$ P Reset

## ELECTRICAL CHARACTERISTICS (continued)

( $V_{BATT} = 1.2V$  to  $5.5V$ ,  $V_{CC} = 1.2V$  to  $5.5V$ ,  $T_A = -40^{\circ}C$  to  $+85^{\circ}C$ , unless otherwise specified. Typical values are at  $T_A = +25^{\circ}C$ .) (Note1)

PARAMETER	SYMBOL	CONDITIONS	MIN	TYP	MAX	UNITS
$\overline{RESET}$ Output High (Push-Pull)	$V_{OH}$	$V_{CC} \geq 1.53V$ , $I_{SOURCE} = 100\mu A$ , $\overline{RESET}$ deasserted	$0.8 \times V_{CC}$			V
		$V_{CC} \geq 2.55V$ , $I_{SOURCE} = 500\mu A$ , $\overline{RESET}$ deasserted	$0.8 \times V_{CC}$			
$\overline{RESET}$ Output Low	$V_{OL}$	$V_{CC} \geq 1.0V$ , $I_{SINK} = 50\mu A$ , $\overline{RESET}$ asserted	0.3			V
		$V_{CC} \geq 1.2V$ , $I_{SINK} = 100\mu A$ , $\overline{RESET}$ asserted	0.3			
		$V_{CC} \geq 2.12V$ , $I_{SINK} = 1.2mA$ , $\overline{RESET}$ asserted	0.3			
$\overline{RESET}$ Output Leakage Current (Open Drain)		$\overline{RESET}$ deasserted	500			nA

**Note 1:** Production testing done at  $T_A = +25^{\circ}C$ ; limits over temperature guaranteed by design only.

**Note 2:** The device is powered up by the highest voltage between  $V_{BATT}$  and  $V_{CC}$ .

**Note 3:**  $\overline{MR}$  input ignores falling input pulses, which occur within the  $\overline{MR}$  debounce period ( $t_{DEB}$ ) after a valid  $\overline{MR}$  reset assertion. This prevents invalid reset assertion due to switch bounce.

## Typical Operating Characteristics

( $V_{BATT} = 1.2V$  to  $5.5V$ ,  $V_{CC} = 1.2V$  to  $5.5V$ , unless otherwise specified. Typical values are at  $T_A = +25^{\circ}C$ .)

**SUPPLY CURRENT vs. TEMPERATURE**  
 $V_{CC} = 3.3V$ ,  $V_{BATT} = 3.6V$

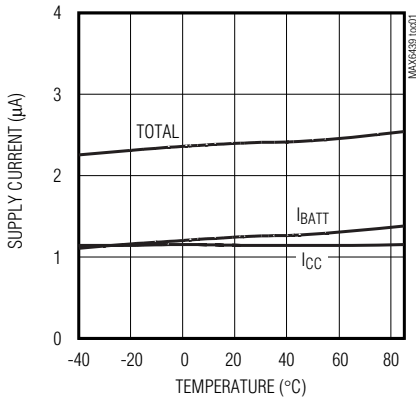

**NORMALIZED  $\overline{LBO}$  TIMEOUT PERIOD vs. TEMPERATURE**

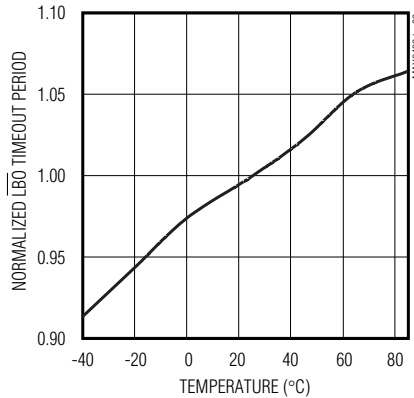

**NORMALIZED  $\overline{RESET}$  TIMEOUT PERIOD vs. TEMPERATURE**

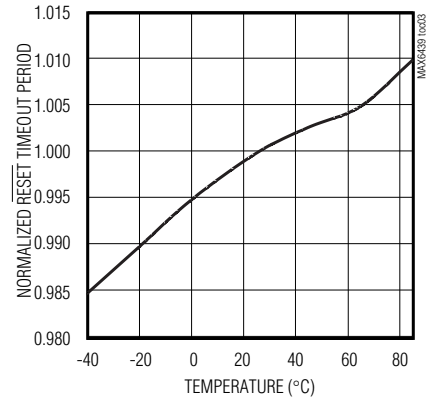

# Low-Power, Single-/Dual-Level Battery Monitors with Hysteresis and Integrated $\mu P$ Reset

## Typical Operating Characteristics (continued)

( $V_{BATT} = 1.2V$  to  $5.5V$ ,  $V_{CC} = 1.2V$  to  $5.5V$ , unless otherwise specified. Typical values are at  $T_A = +25^\circ C$ .)

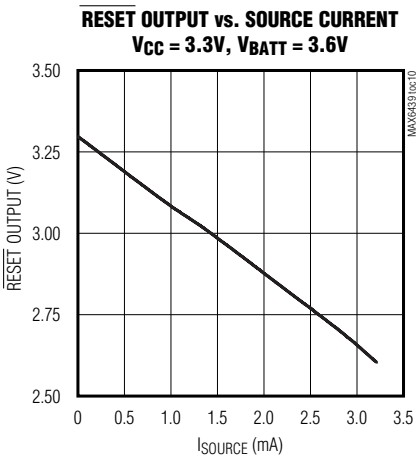
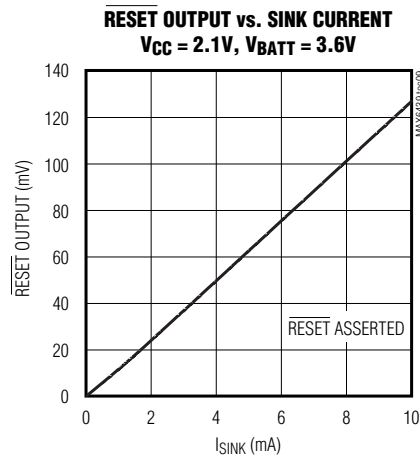
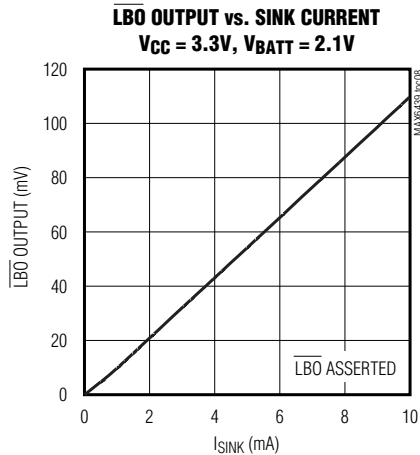
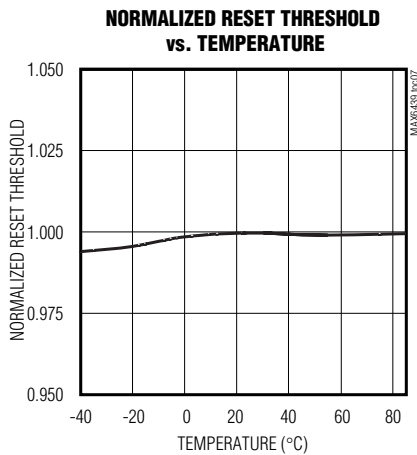
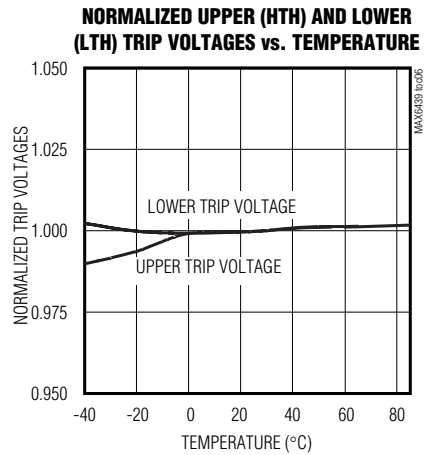
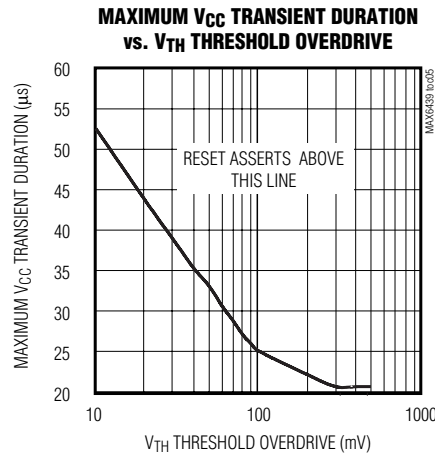
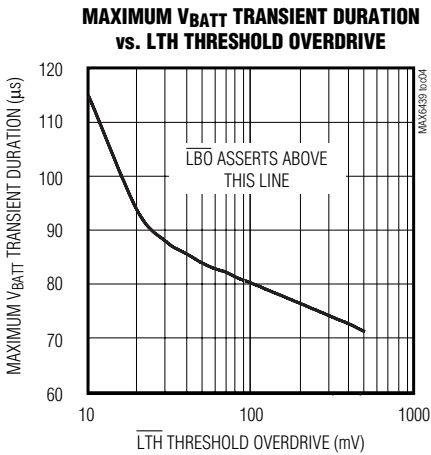

# Low-Power, Single-/Dual-Level Battery Monitors with Hysteresis and Integrated $\mu$ P Reset

## Pin Description

MAX6439-MAX6442

PIN		NAME	FUNCTION
MAX6439/ MAX6440	MAX6441/ MAX6442		
1	1	V <sub>BATT</sub>	Battery Voltage Input. Input for battery voltage threshold monitors and device power supply if V <sub>BATT</sub> is greater than V <sub>CC</sub> .
2	3	$\overline{\text{MR}}$	Manual Reset Input, Active-Low, Internal 1.5k $\Omega$ Pullup to V <sub>CC</sub> . Pull low to assert a one-shot edge-triggered $\overline{\text{RESET}}$ output for the $\overline{\text{MR}}$ reset timeout period. Leave unconnected or connect to V <sub>CC</sub> if unused. The $\overline{\text{MR}}$ input is debounced for $\overline{\text{MR}}$ rising edges to prevent false reset events.
3	—	$\overline{\text{LBO}}$	Low-Battery Output, Active Low, Open Drain. $\overline{\text{LBO}}$ is asserted when V <sub>BATT</sub> drops below the LTH specification and remains asserted until V <sub>BATT</sub> rises above the HTH specification for at least 150ms.
4	5	$\overline{\text{RESET}}$	Reset Output, Active Low, Push-Pull or Open Drain. $\overline{\text{RESET}}$ changes from high to low when the V <sub>CC</sub> input drops below the selected reset threshold and remains low for the V <sub>CC</sub> reset timeout period after V <sub>CC</sub> exceeds the reset threshold. $\overline{\text{RESET}}$ is one-shot edge-trigger pulsed low for the $\overline{\text{MR}}$ reset timeout period when the $\overline{\text{MR}}$ input is pulled low. $\overline{\text{RESET}}$ is an open-drain output for the MAX6439/MAX6441, and a push-pull output for the MAX6440/MAX6442. The push-pull outputs are referenced to V <sub>CC</sub> . $\overline{\text{RESET}}$ is guaranteed to be in the correct logic state for V <sub>BATT</sub> or V <sub>CC</sub> > 1.0V.
5	2	GND	Ground
6	8	V <sub>CC</sub>	V <sub>CC</sub> Voltage Input. Input for V <sub>CC</sub> reset threshold monitor and device power supply if V <sub>CC</sub> is greater than V <sub>BATT</sub> .
—	6	$\overline{\text{LBOH}}$	Low-Battery Output High, Active Low, Open Drain. $\overline{\text{LBOH}}$ is asserted when V <sub>BATT</sub> drops below the HTH- specification. $\overline{\text{LBOH}}$ is deasserted when V <sub>BATT</sub> rises above the HTH+ specification for at least 150ms.
—	7	$\overline{\text{LBOL}}$	Low-Battery Output Low, Active Low, Open Drain. $\overline{\text{LBOL}}$ is asserted when V <sub>BATT</sub> drops below the LTH- specification. $\overline{\text{LBOL}}$ is deasserted when V <sub>BATT</sub> rises above the LTH+ specification for at least 150ms.
—	4	$\overline{\text{LBOLH}}$	Low-Battery Output Low/High, Active Low, Open Drain. $\overline{\text{LBOLH}}$ is asserted when V <sub>BATT</sub> drops below the LTH- specification. $\overline{\text{LBOLH}}$ is deasserted when V <sub>BATT</sub> rises above the HTH+ specification for at least 150ms.

### Detailed Description

The MAX6439-MAX6442 family is available with several monitoring options. The factory-trimmed thresholds eliminate the requirement for external components. The MAX6439/MAX6440 have single low-battery outputs and the MAX6441/MAX6442 have dual low-battery outputs (see Figure 1a and Figure 1b).

The MAX6439-MAX6442 combine a 1.23V reference with two comparators, logic, and timing circuitry to provide the user with information about the charge state of the power-supply batteries. The MAX6441/MAX6442

monitor separate high-voltage and low-voltage thresholds to determine battery status. The output(s) can be used to signal when the battery is charged, when the battery is low, and when the battery is empty. Factory-trimmed thresholds are ideal for monitoring single-cell Li+ or multicell alkaline/NiCd/NiMH power supplies.

When the power-supply voltage drops below the specified low threshold, the low-battery output asserts. When the voltage rises above the specified high threshold following a 150ms (min) timeout period, the low-battery output is deasserted. This ensures the supply voltage

# Low-Power, Single-/Dual-Level Battery Monitors with Hysteresis and Integrated $\mu$ P Reset

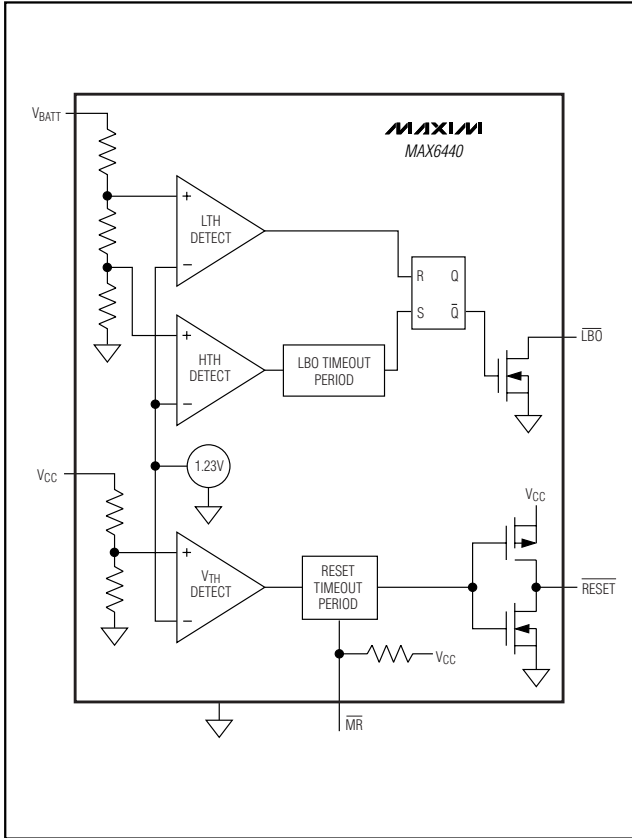

Figure 1a. Functional Diagram

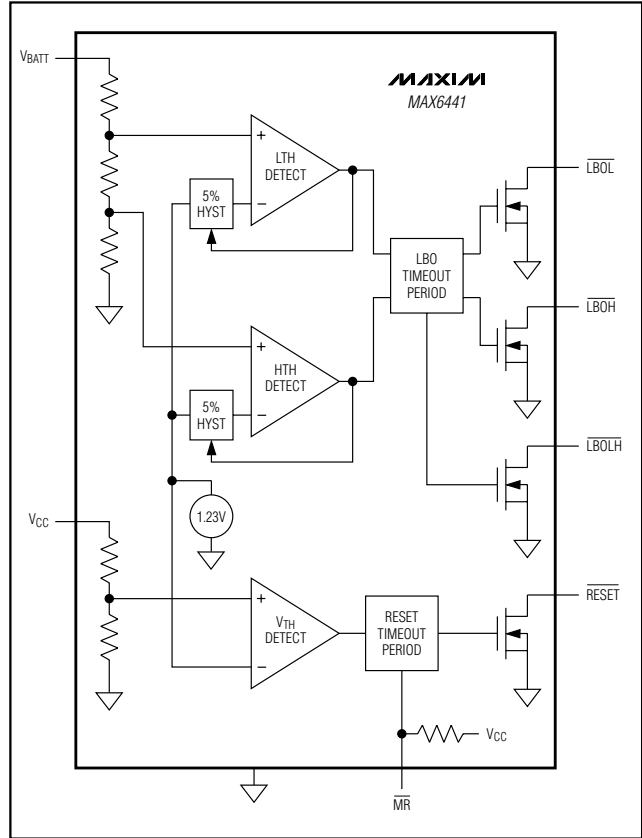

Figure 1b. Functional Diagram

has stabilized before power-converter or microprocessor activity is enabled.

These devices also have an independent  $\mu$ P supervisor that monitors  $V_{CC}$  and provides an active-low reset output. A manual reset function is available to allow the user to reset the  $\mu$ P with a push-button.

### Low-Battery Output

The low-battery outputs are available in active-low ( $\overline{LBO}$ ,  $\overline{LBOL}$ ,  $\overline{LBOH}$ ,  $\overline{LBOLH}$ ), open-drain configurations. The low-battery outputs can be pulled to a voltage independent of  $V_{CC}$  or  $V_{BATT}$ , up to 5.5V. This allows the device to monitor and operate from direct battery voltage while interfacing to higher voltage microprocessors.

The MAX6439/MAX6440 single-output voltage monitors provide a single low-battery output,  $\overline{LBO}$ . These fixed-threshold devices assert  $\overline{LBO}$  when  $V_{BATT}$  drops below  $V_{LTH}$  and remain asserted for at least 150ms after  $V_{BATT}$  rises above  $V_{HTH}$  (see Figure 2). The MAX6441/MAX6442 triple-output voltage monitors provide three

low-battery outputs:  $\overline{LBOH}$ ,  $\overline{LBOL}$ , and  $\overline{LBOLH}$ .  $\overline{LBOH}$  asserts when  $V_{BATT}$  drops below  $V_{HTH-}$  and remains asserted for at least 150ms after  $V_{BATT}$  rises above  $V_{HTH+}$ .  $\overline{LBOL}$  asserts when  $V_{BATT}$  drops below  $V_{LTH-}$  and remains asserted for at least 150ms after  $V_{BATT}$  rises above  $V_{LTH+}$ .  $\overline{LBOLH}$  asserts when  $V_{BATT}$  drops below  $V_{LTH-}$  and remains asserted for at least 150ms after  $V_{BATT}$  rises above  $V_{HTH+}$  (see Figure 3). For fast-rising  $V_{BATT}$  input, the  $\overline{LBOL}$  timeout period must complete before the  $\overline{LBOH}/\overline{LBOLH}$  timeout period begins.

### Reset Output

The MAX6439-MAX6442 provide an active-low reset output ( $\overline{RESET}$ ).  $\overline{RESET}$  is asserted when the voltage at  $V_{CC}$  falls below the reset threshold level. Reset remains asserted for the reset timeout period after  $V_{CC}$  exceeds the threshold. If  $V_{CC}$  goes below the reset threshold before the reset timeout period is completed, the internal timer restarts. The MAX6439/MAX6441 have open-drain reset outputs, while the MAX6440/MAX6442 have push-pull reset outputs (see Figure 4).



# Low-Power, Single-/Dual-Level Battery Monitors with Hysteresis and Integrated $\mu$ P Reset

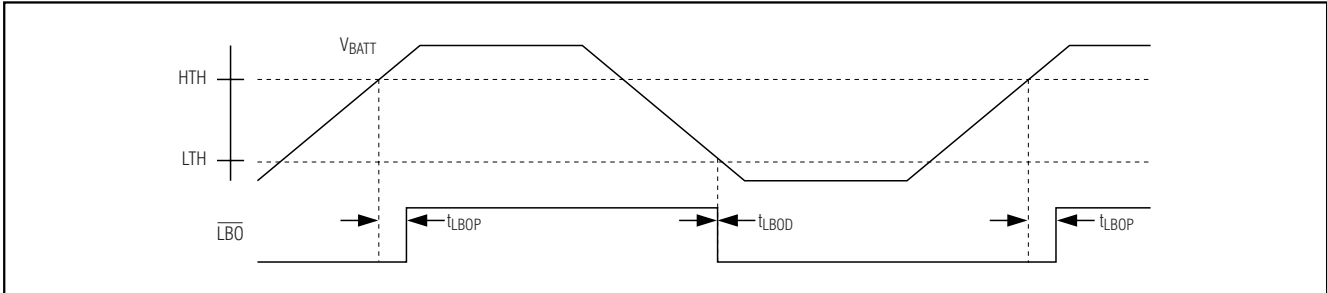

Figure 2. Single Low-Battery Output Timing

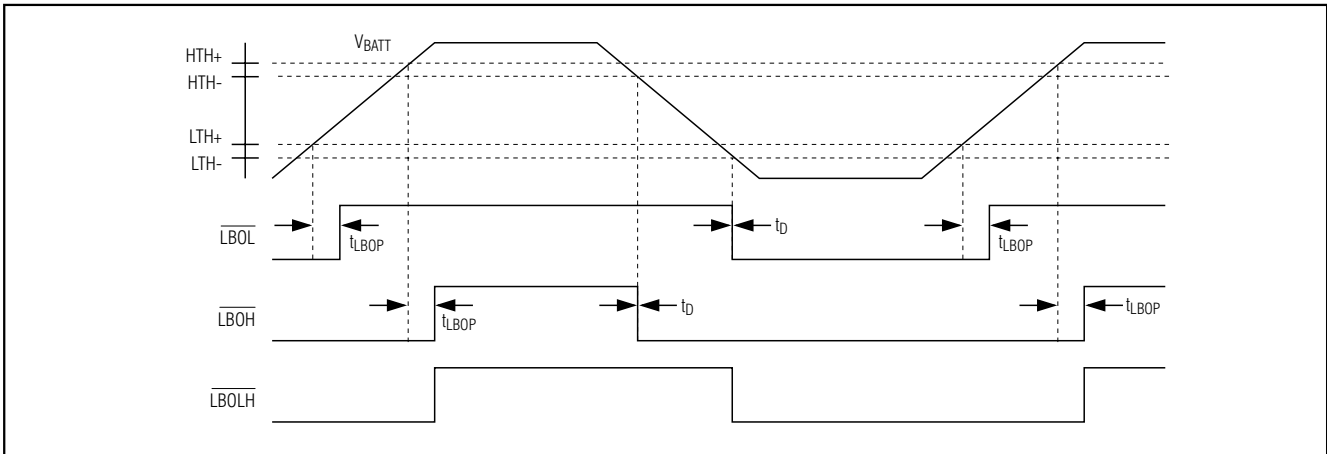

Figure 3. Dual Low-Battery Output Timing

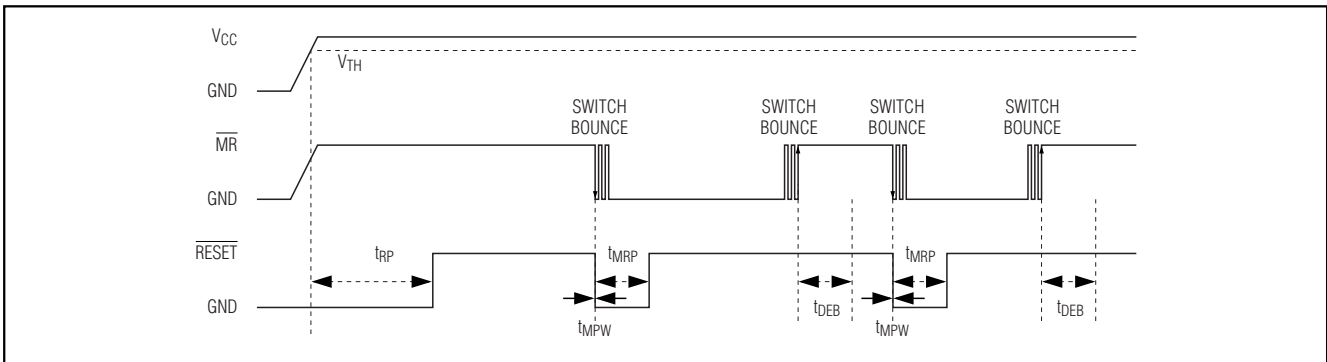

Figure 4.  $\overline{\text{RESET}}$  Timing Diagram

# Low-Power, Single-/Dual-Level Battery Monitors with Hysteresis and Integrated $\mu$ P Reset

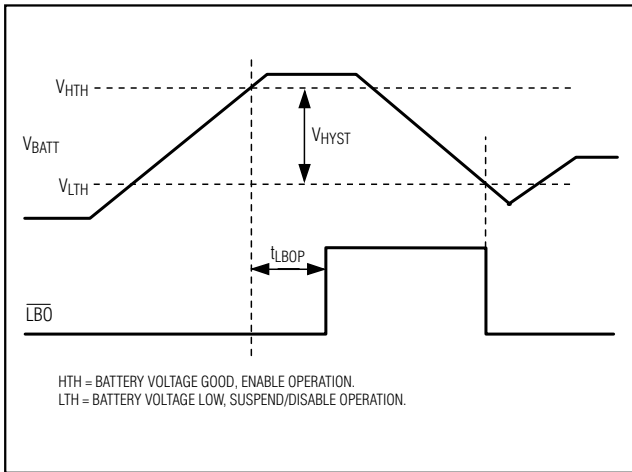

Figure 5. Hysteresis

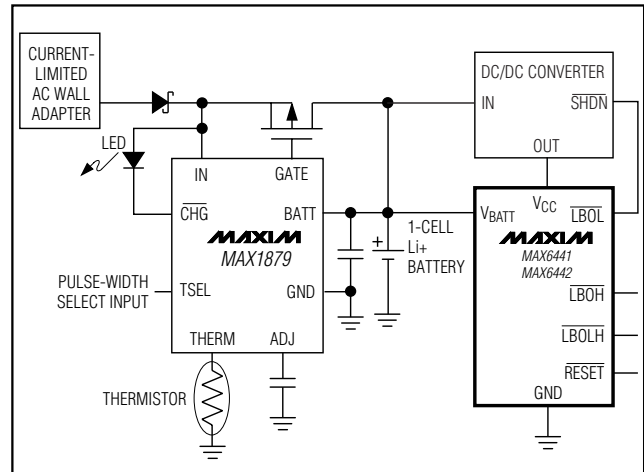

Figure 6. Li+ Charger Application (Using MAX1879)

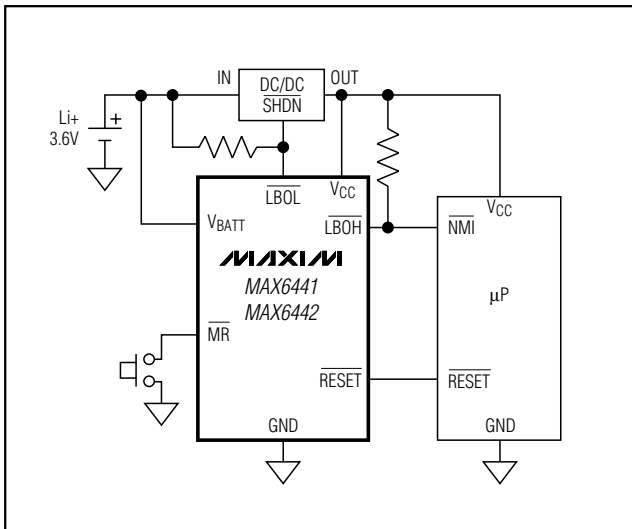

Figure 7. DC-to-DC Converter Application

### Manual Reset

Many microprocessor-based products require manual reset capability, allowing the operator, a test technician, or external logic circuitry to initiate a reset while the monitored supplies remain above their reset thresholds. These devices have a dedicated active-low  $\overline{\text{MR}}$  pin. When  $\overline{\text{MR}}$  is pulled low,  $\overline{\text{RESET}}$  asserts a one-shot low pulse for the  $\overline{\text{MR}}$  reset timeout period. The  $\overline{\text{MR}}$  input has an internal  $1.5\text{k}\Omega$  pullup resistor to  $V_{\text{CC}}$  and can be left unconnected if not used.  $\overline{\text{MR}}$  can be driven with CMOS-

logic levels, open-drain/open-collector outputs, or a momentary push-button switch to GND (the MR function is internally debounced for the  $t_{\text{DEB}}$  timeout period) to create a manual reset function. If  $\overline{\text{MR}}$  is driven from long cables, or if the device is used in a noisy environment, connect a  $0.1\mu\text{F}$  capacitor from  $\overline{\text{MR}}$  to GND to provide additional noise immunity (see Figure 4).

### Hysteresis

Hysteresis increases the comparator's noise margin by increasing the upper threshold or decreasing the lower threshold. The hysteresis prevents the output from oscillating (chattering) when  $V_{\text{BATT}}$  is near the low-battery threshold. This is especially important for applications where the load on the battery creates significant fluctuations in battery voltages (see Figure 5).

## Applications Information

### Li+ Battery Charger Application

The MAX6441/MAX6442 dual-output battery monitors can be used in conjunction with a battery charger to provide a system with additional information about the battery charge state. Many battery chargers, such as the MAX1879, provide the user with a CHG output, which tells the system when the battery is charged. The MAX6441/MAX6442 dual-output battery monitors provide three outputs, which can be used to relay the battery condition to the system. This information is useful in determining which system resources can be powered by the battery at the current charge state (see Figure 6).

# Low-Power, Single-/Dual-Level Battery Monitors with Hysteresis and Integrated $\mu$ P Reset

**Table 1. Factory-Trimmed Lower and Upper Threshold Combinations for Single-Cell Li+ or Three-Cell Alkaline/NiCd/NiMH Applications**

LOWER THRESHOLD (LTH)	VOLTAGES	UPPER THRESHOLD (HTH)			
		3.3V	3.4V	3.5V	3.6V
2.6V	AG	AH	AI	AJ	
2.7V	BG	BH	BI	BJ	
2.8V	CG	CH	CI	CJ	
2.9V	DG	DH	DI	DJ	
3.0V	EG	EH	EI	EJ	
3.1V	FG	FH	FI	FJ	

**Table 2. Factory-Trimmed Lower and Upper Threshold Combinations for Two-Cell Alkaline/NiCd/NiMH Applications**

LOWER THRESHOLD (LTH)	VOLTAGES	UPPER THRESHOLD (HTH)			
		2.3V	2.4V	2.5V	2.6V
1.6V	KQ	KR	KS	KT	
1.7V	LQ	LR	LS	LT	
1.8V	MQ	MR	MS	MT	
1.9V	NQ	NR	NS	NT	
2.0V	OQ	OR	OS	OT	
2.1V	PQ	PR	PS	PT	

**Table 3. Factory-Trimmed VCC Reset Threshold Levels**

PART NO. SUFFIX ( _ )	VCC NOMINAL RESET THRESHOLD (V)
T	3.075
S	2.925
R	2.625
Z	2.313
Y	2.188
W	1.665
V	1.575

### DC-to-DC Converter Application

The MAX6441/MAX6442 triple-output battery monitors can be used in conjunction with a DC-to-DC converter to power microprocessor systems using a single Li+ cell or two to three alkaline/NiCd/NiMH cells. The LBOH output indicates that the battery voltage is weak, and is used to warn the microprocessor of potential problems. Armed with this information, the microprocessor can

**Table 4. VCC Reset Timeout Period Suffix Guide**

TIMEOUT PERIOD SUFFIX	ACTIVE TIMEOUT PERIOD (ms)	
	MIN	MAX
D3	150	300
D7	1200	2400

reduce system power consumption. The  $\overline{\text{LBOL}}$  output indicates the battery is empty, and system power should be disabled. By connecting  $\overline{\text{LBOL}}$  to the SHDN pin of the DC-to-DC converter, power to the microprocessor is removed. Microprocessor power does not return until the battery has recharged to a voltage greater than  $V_{\text{LTH+}}$  (see Figure 7).

# Low-Power, Single-/Dual-Level Battery Monitors with Hysteresis and Integrated $\mu$ P Reset

## Selector Guide

PART	OPEN-DRAIN RESET	PUSH-PULL RESET	SINGLE LOW-BATTERY OUTPUT	DUAL LOW-BATTERY OUTPUT
MAX6439	X	—	X	—
MAX6440	—	X	X	—
MAX6441	X	—	—	X
MAX6442	—	X	—	X

## Standard Versions Table

PART	TOP MARK
MAX6439UTDHRD3	ABMN
MAX6439UTDHSD3	ABMO
MAX6439UTEHRD3	ABMP
MAX6439UTEHSD3	ABMQ
MAX6439UTEIRD3	ABMR
MAX6439UTEISD3	ABMS
MAX6440UTDHRD3	ABMT
MAX6440UTDHSD3	ABMU
MAX6440UTEHRD3	ABMV
MAX6440UTEHSD3	ABMW
MAX6440UTEIRD3	ABMX
MAX6440UTEISD3	ABMY
MAX6441KADHRD3	AEEI
MAX6441KADHSD3	AEEJ
MAX6441KAEHRD3	AEEK
MAX6441KAEHSD3	AEEL
MAX6441KAEIRD3	AEEM
MAX6441KAEISD3	AEEN
MAX6442KADHRD3	AEEQ
MAX6442KADHSD3	AEEP
MAX6442KAEHRD3	AEEQ
MAX6442KAEHSD3	AEER
MAX6442KAEIRD3	AEES
MAX6442KAEISD3	AEET

## Typical Application Circuit

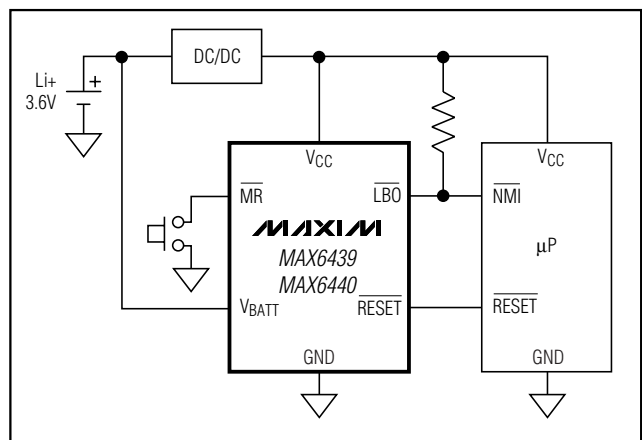

## Pin Configurations (continued)

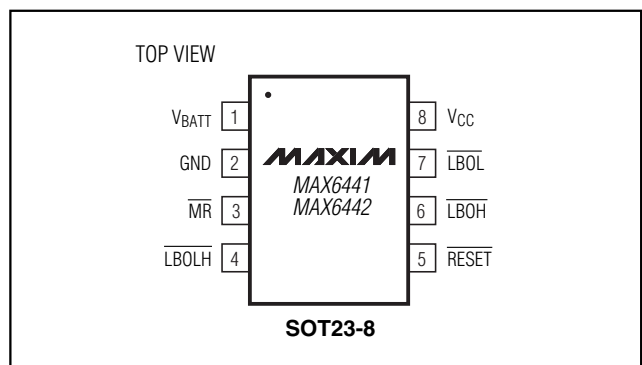

## Chip Information

TRANSISTOR COUNT: 1478  
 PROCESS: BiCMOS

# Low-Power, Single-/Dual-Level Battery Monitors with Hysteresis and Integrated $\mu$ P Reset

## Package Information

(The package drawing(s) in this data sheet may not reflect the most current specifications. For the latest package outline information, go to [www.maxim-ic.com/packages](http://www.maxim-ic.com/packages).)

MAX6439-MAX6442

6LSOT.EPS

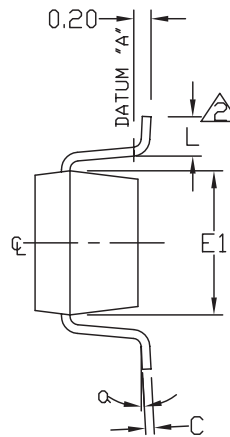
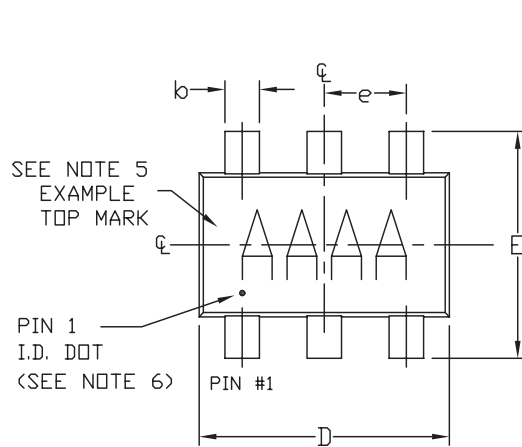

SYMBOL	MIN	MAX
A	0.90	1.45
A1	0.00	0.15
A2	0.90	1.30
b	0.35	0.50
C	0.08	0.20
D	2.80	3.00
E	2.60	3.00
E1	1.50	1.75
L	0.35	0.55
e	0.95 REF	
$\alpha$	0°	10°

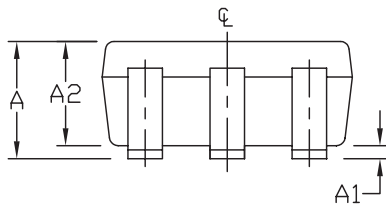

### NOTES:

1. ALL DIMENSIONS ARE IN MILLIMETERS.
2.  $\triangle$  FOOT LENGTH MEASURED AT INTERCEPT POINT BETWEEN DATUM A & LEAD SURFACE.
3. PACKAGE OUTLINE EXCLUSIVE OF MOLD FLASH & METAL BURR.
4. PACKAGE OUTLINE INCLUSIVE OF SOLDER PLATING.
5. PIN 1 IS LOWER LEFT PIN WHEN READING TOP MARK FROM LEFT TO RIGHT. (SEE EXAMPLE TOP MARK)
6. PIN 1 I.D. DOT IS 0.3 MM  $\phi$  MIN. LOCATED ABOVE PIN 1.
7. MEETS JEDEC MO178.

<b>MAXIM</b>			
PROPRIETARY INFORMATION			
TITLE:			
PACKAGE OUTLINE, SOT-23, 6L			
APPROVAL	DOCUMENT CONTROL NO.	REV	1/1
	21-0058	E	

# Low-Power, Single-/Dual-Level Battery Monitors with Hysteresis and Integrated $\mu$ P Reset

## Package Information (continued)

(The package drawing(s) in this data sheet may not reflect the most current specifications. For the latest package outline information, go to [www.maxim-ic.com/packages](http://www.maxim-ic.com/packages).)

SOT23, 8LEPS

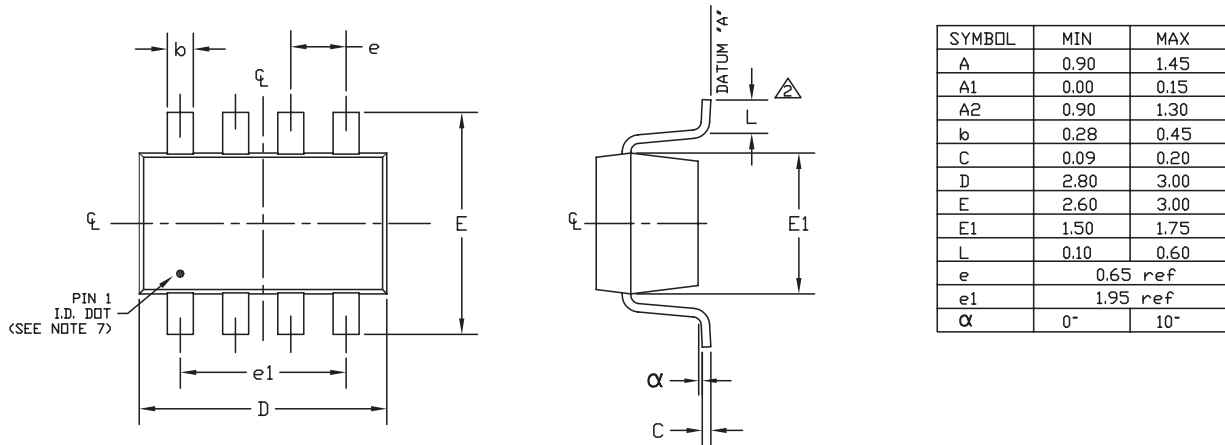

- NOTE:
1. ALL DIMENSIONS ARE IN MILLIMETERS.
  2.  $\triangle$  FOOT LENGTH MEASURED REFERENCE TO FLAT FOOT SURFACE PARALLEL TO DATUM 'A'.
  3. PACKAGE OUTLINE EXCLUSIVE OF MOLD FLASH & METAL BURR.
  4. PACKAGE OUTLINE INCLUSIVE OF SOLDER PLATING.
  5. EIAJ REF. NUMBER SC-74 (6 LEAD VERSION)
  6. COPLANARITY 4 MILS. MAX.
  7. PIN 1 I.D. DOT IS 0.3 MM  $\phi$  MIN. LOCATED ABOVE PIN 1.
  8. MEETS JEDEC MO178.

<b>MAXIM</b>		
<small>PROPRIETARY INFORMATION</small>		
<small>TITLE</small>		
PACKAGE OUTLINE, SOT-23, 8L		
<small>APPROVAL</small>	<small>DOCUMENT CONTROL NO.</small>	<small>REV</small>
	21-0078	C 1/1

Maxim cannot assume responsibility for use of any circuitry other than circuitry entirely embodied in a Maxim product. No circuit patent licenses are implied. Maxim reserves the right to change the circuitry and specifications without notice at any time.

14 \_\_\_\_\_ **Maxim Integrated Products, 120 San Gabriel Drive, Sunnyvale, CA 94086 408-737-7600**