



# CAT5114

## 32-Tap Digitally Programmable Potentiometer (DPP)

### FEATURES

- 32 Position Linear Taper Potentiometer
- Nonvolatile Wiper Storage
- Low Power CMOS Technology
- Single Supply Operation: 2.5V-6.0V
- Increment Up/Down Serial Interface
- Resistance Values: 10K, 20K, 50K and 100K  $\Omega$
- Available in PDIP, SOIC, TSSOP and MSOP packages

### APPLICATIONS

- Automated Product Calibration
- Remote Control Adjustments
- Offset, Gain and Zero Control Systems
- Tamper-Proof Calibrations
- Contrast, Brightness and Volume Controls
- Motor Controls and Feedback Systems
- Programmable Analog Functions

### DESCRIPTION

The CAT5114 is a single digitally programmable potentiometer (DPP) designed as an electronic replacement for mechanical potentiometers and trim pots. Ideal for automated adjustments on high volume production lines, they are also well suited for applications where equipment requiring periodic adjustment is either difficult to access or located in a hazardous or remote environment.

The CAT5114 contains a 32-tap series resistor array connected between two terminals  $R_H$  and  $R_L$ . An up/down counter and decoder that are controlled by three input pins, determines which tap is connected to the wiper,  $R_W$ . The wiper setting, stored in nonvolatile memory, is not lost when the device is powered down and is automatically reinstated when power is returned. The wiper can be adjusted to test

new system values without effecting the stored setting. Wiper-control of the CAT5114 is accomplished with three input control pins,  $\overline{CS}$ ,  $U/\overline{D}$ , and  $\overline{INC}$ . The  $\overline{INC}$  input increments the wiper in the direction which is determined by the logic state of the  $U/\overline{D}$  input. The  $\overline{CS}$  input is used to select the device and also store the wiper position prior to power down.

The digitally programmable potentiometer can be used as a three-terminal resistive divider or as a two-terminal variable resistor. DPPs bring variability and programmability to a wide variety of applications including control, parameter adjustments, and signal processing.

### FUNCTIONAL DIAGRAM

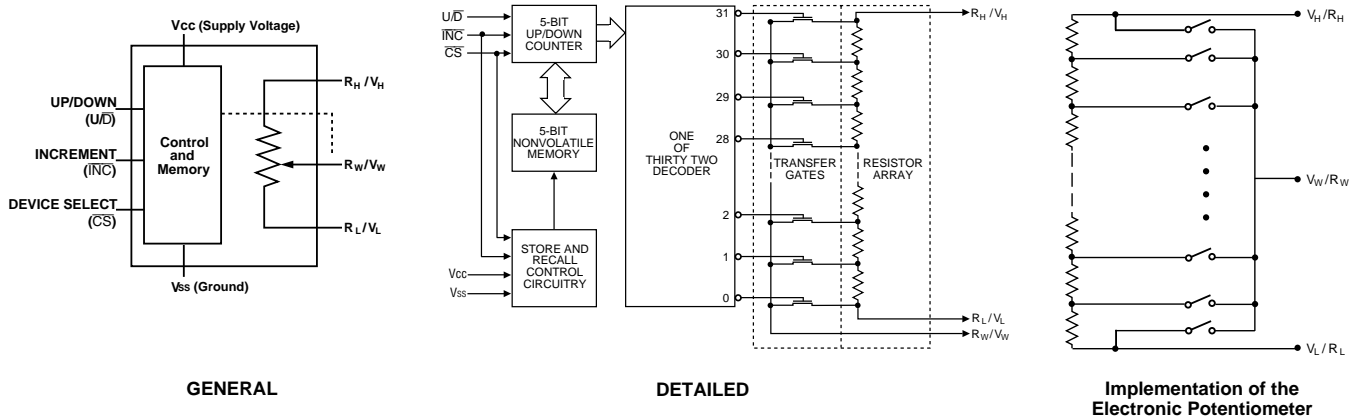

## PIN CONFIGURATION

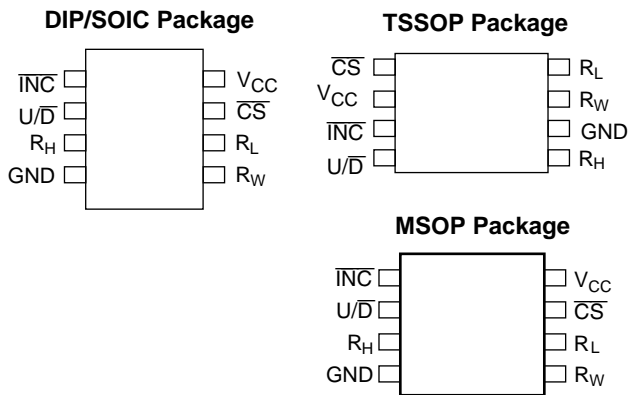

## PIN DESCRIPTIONS

 **$\overline{INC}$ :** Increment Control Input

The  $\overline{INC}$  input moves the wiper in the up or down direction determined by the condition of the  $U/\overline{D}$  input.

 **$U/\overline{D}$ :** Up/Down Control Input

The  $U/\overline{D}$  input controls the direction of the wiper movement. When in a high state and  $\overline{CS}$  is low, any high-to-low transition on  $\overline{INC}$  will cause the wiper to move one increment toward the  $R_H$  terminal. When in a low state and  $\overline{CS}$  is low, any high-to-low transition on  $\overline{INC}$  will cause the wiper to move one increment towards the  $R_L$  terminal.

 **$R_H$ :** High End Potentiometer Terminal

$R_H$  is the high end terminal of the potentiometer. It is not required that this terminal be connected to a potential greater than the  $R_L$  terminal. Voltage applied to the  $R_H$  terminal cannot exceed the supply voltage,  $V_{CC}$  or go below ground, GND.

 **$R_W$ :** Wiper Potentiometer Terminal

$R_W$  is the wiper terminal of the potentiometer. Its position on the resistor array is controlled by the control inputs,  $\overline{INC}$ ,  $U/\overline{D}$  and  $\overline{CS}$ . Voltage applied to the  $R_W$  terminal cannot exceed the supply voltage,  $V_{CC}$  or go below ground, GND.

 **$R_L$ :** Low End Potentiometer Terminal

$R_L$  is the low end terminal of the potentiometer. It is not required that this terminal be connected to a potential less than the  $R_H$  terminal. Voltage applied to the  $R_L$  terminal cannot exceed the supply voltage,  $V_{CC}$  or go below ground, GND.  $R_L$  and  $R_H$  are electrically interchangeable.

 **$\overline{CS}$ :** Chip Select

The chip select input is used to activate the control input

## PIN FUNCTIONS

Pin Name	Function
$\overline{INC}$	Increment Control
$U/\overline{D}$	Up/Down Control
$R_H$	Potentiometer High Terminal
GND	Ground
$R_W$	Potentiometer Wiper Terminal
$R_L$	Potentiometer Low Terminal
$\overline{CS}$	Chip Select
$V_{CC}$	Supply Voltage

of the CAT5114 and is active low. When in a high state, activity on the  $\overline{INC}$  and  $U/\overline{D}$  inputs will not affect or change the position of the wiper.

## DEVICE OPERATION

The CAT5114 operates like a digitally controlled potentiometer with  $R_H$  and  $R_L$  equivalent to the high and low terminals and  $R_W$  equivalent to the mechanical potentiometer's wiper. There are 32 available tap positions including the resistor end points,  $R_H$  and  $R_L$ . There are 31 resistor elements connected in series between the  $R_H$  and  $R_L$  terminals. The wiper terminal is connected to one of the 32 taps and controlled by three inputs,  $\overline{INC}$ ,  $U/\overline{D}$  and  $\overline{CS}$ . These inputs control a five-bit up/down counter whose output is decoded to select the wiper position. The selected wiper position can be stored in nonvolatile memory using the  $\overline{INC}$  and  $\overline{CS}$  inputs.

With  $\overline{CS}$  set LOW the CAT5114 is selected and will respond to the  $U/\overline{D}$  and  $\overline{INC}$  inputs. HIGH to LOW transitions on  $\overline{INC}$  will increment or decrement the wiper (depending on the state of the  $U/\overline{D}$  input and five-bit counter). The wiper, when at either fixed terminal, acts like its mechanical equivalent and does not move beyond the last position. The value of the counter is stored in nonvolatile memory whenever  $\overline{CS}$  transitions HIGH while the  $\overline{INC}$  input is also HIGH. When the CAT5114 is powered-down, the last stored wiper counter position is maintained in the nonvolatile memory. When power is restored, the contents of the memory are recalled and the counter is set to the value stored.

With  $\overline{INC}$  set low, the CAT5114 may be de-selected and powered down without storing the current wiper position in nonvolatile memory. This allows the system to always power up to a preset value stored in nonvolatile memory.

**OPERATION MODES**

$\overline{INC}$	$\overline{CS}$	U/D	Operation
High to Low	Low	High	W toward H
High to Low	Low	Low	W toward L
High	Low to High	X	Store Wiper Position
Low	Low to High	X	No Store, Return to Standby
X	High	X	Standby

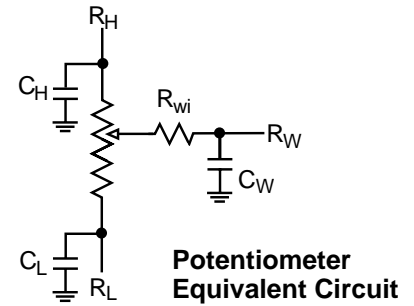

**ABSOLUTE MAXIMUM RATINGS**

Supply Voltage  
 $V_{CC}$  to GND ..... -0.5V to +7V

Inputs

$\overline{CS}$ to GND	-0.5V to $V_{CC} + 0.5V$
$\overline{INC}$ to GND	-0.5V to $V_{CC} + 0.5V$
U/D to GND	-0.5V to $V_{CC} + 0.5V$
H to GND	-0.5V to $V_{CC} + 0.5V$
L to GND	-0.5V to $V_{CC} + 0.5V$
W to GND	-0.5V to $V_{CC} + 0.5V$

Operating Ambient Temperature

Commercial ('C' suffix)	0°C to +70°C
Industrial ('I' suffix)	-40°C to +85°C
Junction Temperature	+150°C
Storage Temperature	-65°C to +150°C
Lead Soldering (10 sec max)	+300°C

\* Stresses above those listed under Absolute Maximum Ratings may cause permanent damage to the device. Absolute Maximum Ratings are limited values applied individually while other parameters are within specified operating conditions, and functional operation at any of these conditions is NOT implied. Device performance and reliability may be impaired by exposure to absolute rating conditions for extended periods of time.

**RELIABILITY CHARACTERISTICS**

Symbol	Parameter	Min	Max	Units	Test Method
$V_{ZAP}^{(1)}$	ESD Susceptibility	2000		Volts	MIL-STD-883, Test Method 3015
$I_{LTH}^{(1)(2)}$	Latch-Up	100		mA	JEDEC Standard 17
$T_{DR}$	Data Retention	100		Years	MIL-STD-883, Test Method 1008
$N_{END}$	Endurance	1,000,000		Stores	MIL-STD-883, Test Method 1003

**DC Electrical Characteristics:  $V_{CC} = +2.5V$  to  $+6.0V$  unless otherwise specified**

**Power Supply**

Symbol	Parameter	Conditions	Min	Typ	Max	Units
$V_{CC}$	Operating Voltage Range		2.5	—	6.0	V
$I_{CC1}$	Supply Current (Increment)	CAT5114 $V_{CC} = 6V, f = 1MHz, I_W=0$ $V_{CC} = 6V, f = 250KHz, I_W=0$	—	—	100 50	$\mu A$
$I_{CC2}$	Supply Current (Write)	Programming, $V_{CC} = 6V$ $V_{CC} = 3V$	—	—	1 500	mA $\mu A$
$ISB_1^{(2)}$	Supply Current (Standby)	CAT5114 $CS = V_{CC} - 0.3V$ $U/D, INC = V_{CC} - 0.3V$ or GND	—	—	1	$\mu A$

**Logic Inputs**

Symbol	Parameter	Conditions	Min	Typ	Max	Units
$I_{IH}$	Input Leakage Current	$V_{IN} = V_{CC}$	—	—	10	$\mu A$
$I_{IL}$	Input Leakage Current	$V_{IN} = 0V$	—	—	-10	$\mu A$
$V_{IH1}$	TTL High Level Input Voltage	$4.5V \leq V_{CC} \leq 5.5V$	2	—	$V_{CC}$	V
$V_{IL1}$	TTL Low Level Input Voltage		0	—	0.8	V
$V_{IH2}$	CMOS High Level Input Voltage	$2.5V \leq V_{CC} \leq 6V$	$V_{CC} \times 0.7$	—	$V_{CC} + 0.3$	V
$V_{IL2}$	CMOS Low Level Input Voltage		-0.3	—	$V_{CC} \times 0.2$	V

- NOTES:**
- (1) This parameter is tested initially and after a design or process change that affects the parameter.
  - (2) Latch-up protection is provided for stresses up to 100mA on address and data pins from -1V to  $V_{CC} + 1V$
  - (3)  $I_W$ =source or sink
  - (4) These parameters are periodically sampled and are not 100% tested.

## Potentiometer Parameters

Symbol	Parameter	Conditions	Min	Typ	Max	Units
R <sub>POT</sub>	Potentiometer Resistance			10K $\Omega$ 20K $\Omega$ 50K $\Omega$ 100K $\Omega$		
	Pot Resistance Tolerance				$\pm 15$	%
V <sub>RH</sub>	Voltage on R <sub>H</sub> pin		OV		V <sub>CC</sub>	V
V <sub>RL</sub>	Voltage on R <sub>L</sub> pin		OV		V <sub>CC</sub>	V
	Resolution			3.2		%
INL	Integral Linearity Error	I <sub>W</sub> $\leq$ 2 $\mu$ A		0.5	1	LSB
DNL	Differential Linearity Error	I <sub>W</sub> $\leq$ 2 $\mu$ A		0.25	.5	LSB
R <sub>Wi</sub>	Wiper Resistance	V <sub>CC</sub> = 5V, I <sub>W</sub> = 1mA			400	$\Omega$
		V <sub>CC</sub> = 2.5V, I <sub>W</sub> = 1mA			1K	$\Omega$
I <sub>W</sub>	Wiper Current				1	mA
TC <sub>R<sub>POT</sub></sub>	TC of Pot Resistance					ppm/ $^{\circ}$ C
TC <sub>R<sub>RATIO</sub></sub>	Ratiometric TC					ppm/ $^{\circ}$ C
R <sub>ISO</sub>	Isolation Resistance					$\Omega$
V <sub>N</sub>	Noise					nV/ $\sqrt{\text{Hz}}$
C <sub>H</sub> /C <sub>L</sub> /C <sub>W</sub>	Potentiometer Capacitances			10/10/25		pF

**AC CONDITIONS OF TEST**

V <sub>CC</sub> Range	2.5V ≤ V <sub>CC</sub> ≤ 6V
Input Pulse Levels	0.2V <sub>CC</sub> to 0.7V <sub>CC</sub>
Input Rise and Fall Times	10ns
Input Reference Levels	0.5V <sub>CC</sub>

**AC OPERATING CHARACTERISTICS:**

V<sub>CC</sub> = +2.5V to +6.0V, V<sub>H</sub> = V<sub>CC</sub>, V<sub>L</sub> = 0V, unless otherwise specified

Symbol	Parameter	Limits			Units
		Min	Typ <sup>(1)</sup>	Max	
t <sub>CI</sub>	$\overline{CS}$ to INC Setup	100	—	—	ns
t <sub>DI</sub>	U/ $\overline{D}$ to $\overline{INC}$ Setup	50	—	—	ns
t <sub>DD</sub>	U/ $\overline{D}$ to $\overline{INC}$ Hold	100	—	—	ns
t <sub>IL</sub>	$\overline{INC}$ LOW Period	250	—	—	ns
t <sub>IH</sub>	$\overline{INC}$ HIGH Period	250	—	—	ns
t <sub>IC</sub>	$\overline{INC}$ Inactive to $\overline{CS}$ Inactive	1	—	—	μs
t <sub>CPH</sub>	$\overline{CS}$ Deselect Time (NO STORE)	100	—	—	ns
t <sub>CPH</sub>	$\overline{CS}$ Deselect Time (STORE)	10	—	—	ms
t <sub>IW</sub>	$\overline{INC}$ to V <sub>OUT</sub> Change	—	1	5	μs
t <sub>CYC</sub>	$\overline{INC}$ Cycle Time	1	—	—	μs
t <sub>R</sub> , t <sub>F</sub> <sup>(2)</sup>	$\overline{INC}$ Input Rise and Fall Time	—	—	500	μs
t <sub>PU</sub> <sup>(2)</sup>	Power-up to Wiper Stable	—	—	1	msec
t <sub>R</sub> V <sub>CC</sub> <sup>(2)</sup>	V <sub>CC</sub> Power-up Rate	0.2	—	50	V/ms
t <sub>WR</sub>	Store Cycle	—	5	10	ms

**A. C. TIMING**

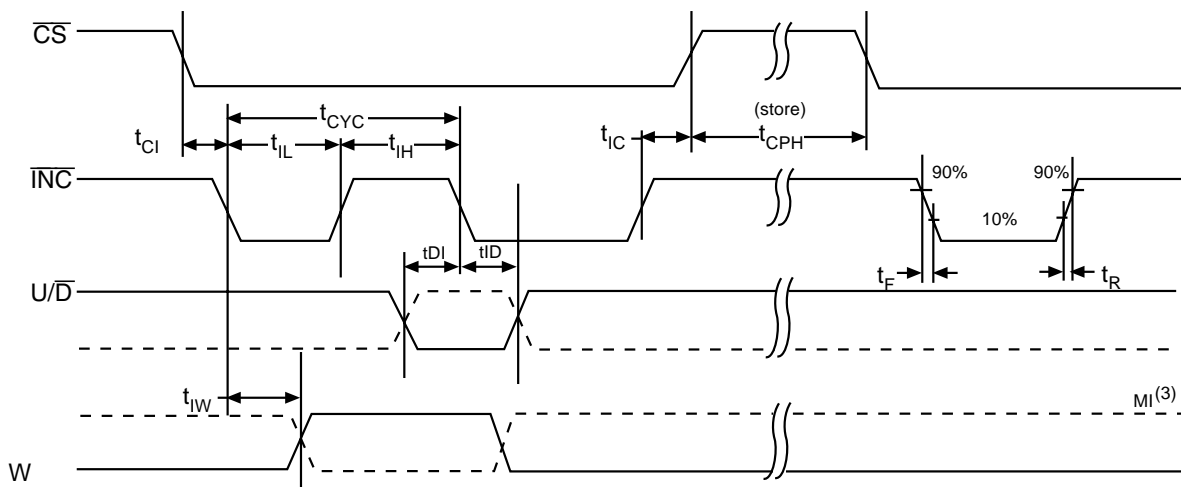

(1) Typical values are for T<sub>A</sub>=25°C and nominal supply voltage.  
 (2) This parameter is periodically sampled and not 100% tested.  
 (3) MI in the A.C. Timing diagram refers to the minimum incremental change in the W output due to a change in the wiper position.

**ORDERING INFORMATION**

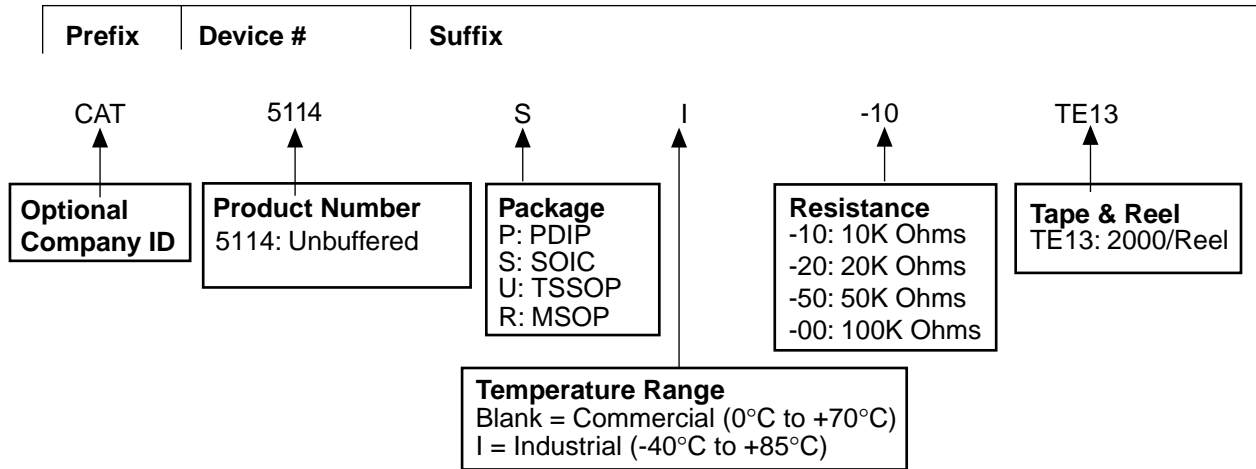

Notes:

(1) The device used in the above example is a CAT5114 SI-10TE13 (SOIC, 10K Ohms, Industrial Temperature, Tape & Reel)