



AS2214

Primary Side PWM Controller

Features

- Low Startup Current
- Bulk and AC sensing
- Soft Start
- Single-start or auto-restart modes
- Oscillator trimmed for precision duty cycle clamp
- Standard temperature range extended to 105°C
- Remote on / off control
- Buffered Ramp for slope compensation
- Standard current mode control

Description

The AS2214 is a full featured, pulse width modulation controller. Based on an improved AS3842, the AS2214 provides additional features that reduce component count and improve specifications in a wide range of power supply designs. The added functionality includes AC power and bulk voltage sensing, over-voltage input, as well as the ability to latch off or bounce through different fault conditions.

The PWM function is controlled by the current sense comparator for normal current mode control and a second comparator for voltage mode soft start. A buffered RAMP signal is available for slope compensation without loading the oscillator. The output stage is a high current totem pole output that sees only 85 ns delay from the PWM comparator.

The AS2214 requires less than 10µA of startup current. The undervoltage lockout (UVLO) thresholds are nominally 13.8V for turn on and 8 V for turn off. A precision 2.5 V bandgap reference serves as an input for the error amplifier. The oscillator discharge current is trimmed to provide guaranteed duty cycle clamping.

Pin Configuration — Top view

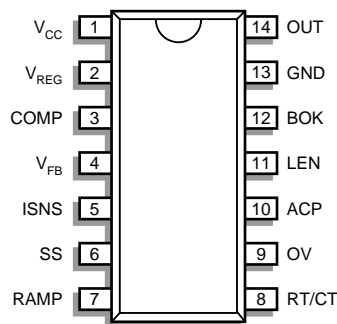

Ordering Information

Package	Temperature Range	Order Code
14-Pin Plastic DIP	0 to 105° C	AS2214N

Functional Block Diagram

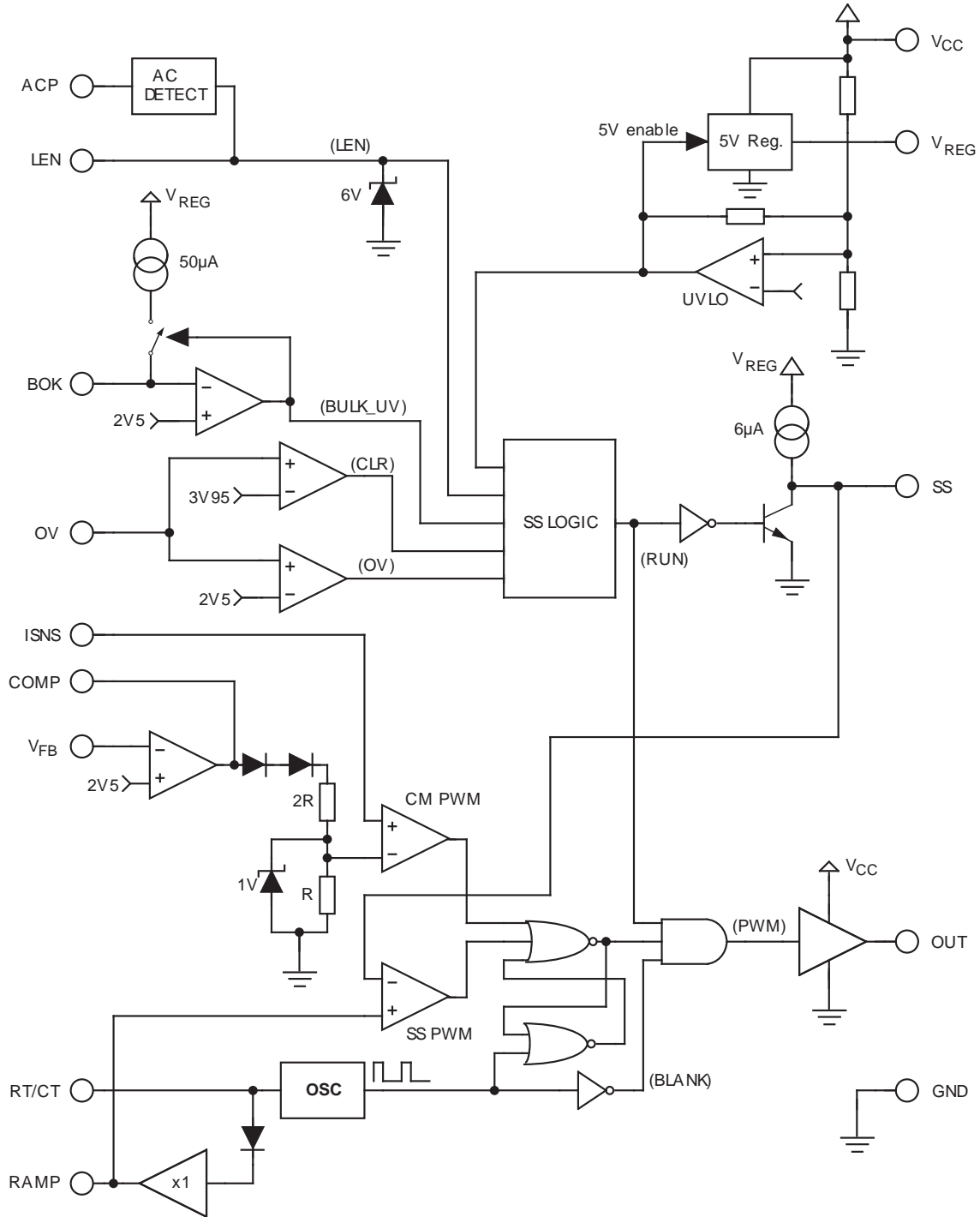

AS2214 Soft Start Logic

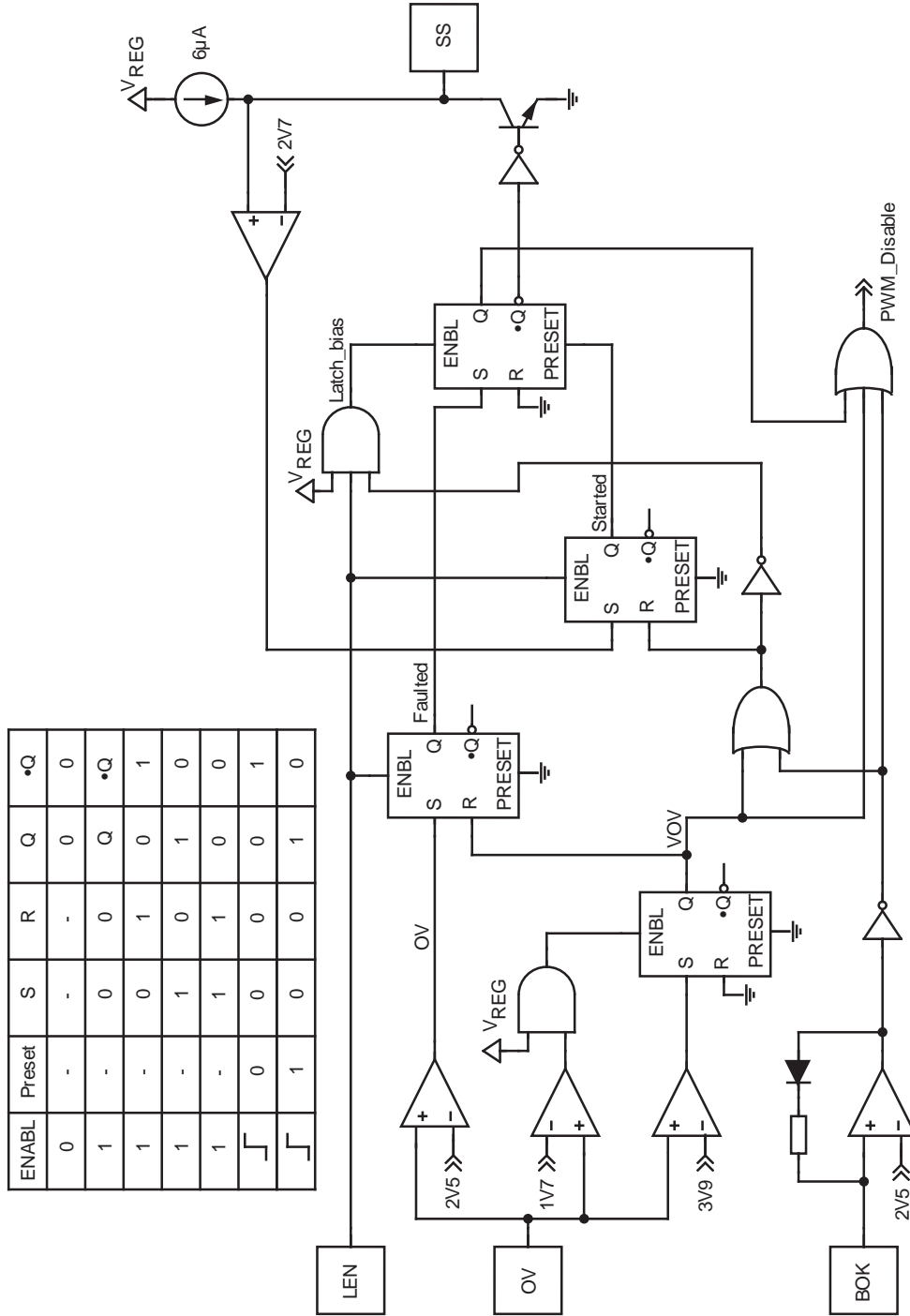

Pin Function Description

Pin Number	Function	Description
1	V _{CC}	Positive supply voltage for the IC.
2	V _{REG}	Output of 5V series regulator.
3	COMP	This pin is the error amplifier output. Typically used to provide loop compensation to maintain V _{FB} at 2.5 V.
4	V _{FB}	Inverting input of the error amplifier. The non-inverting input is a trimmed 2.5 V bandgap reference.
5	ISNS	A voltage proportional to inductor current is connected to this pin. The PWM uses this information to terminate the gate drive of the output.
6	SS	This pin provides a 6μA current source to linearly charge an external capacitor. This pin is compared to the RAMP pin in the soft start comparator, terminating output pulses when RAMP goes above the SS voltage.
7	RAMP	This pin is a level-shifted and buffered oscillator signal used to provide slope compensation to the current sense signal. The pin also serves as the non-inverting input of the soft-start comparator.
8	RT/CT	Oscillator frequency and maximum duty cycle are set by connecting a resistor (R _T) to V _{REG} and a capacitor (C _T) to ground.
9	OV	This pin latches SS low when pulled above 2.5 V. The latch can be reset by pulling OV above 4 V then back to ground.
10	ACP	This pin detects the presence of AC signal and drives LEN high.
11	LEN	This pin must be high to enable starting. The pin can also clear all latches by going low then high.
12	BOK	This pin monitors the bulk voltage through a resistor divider and, when BOK exceeds 2.5 V, provides a 50μA current source for hysteresis. When BOK drops below 2.5V, SS is pulled low and the hysteresis current is turned off. Auto-restart after a brown-out is possible.
13	GND	Circuit common ground.
14	OUT	This totem pole output is designed to directly drive a power MOSFET switch capable of sourcing and sinking peak currents up to 1 A.

Absolute Maximum Ratings

Parameter	Symbol	Rating	Unit
Reference Current	I _{REF}	200	mA
Output Current	I _{OUT}	1	A
Supply Voltage	V _{CC}	20	V
Output Voltage	V _{OUT}	20	V
Continuous Power Dissipation at 25° C	P _D	500	mW
Junction Temperature	T _J	150	°C
Storage Temperature Range	T _{STG}	-65 to 150	°C
Lead Temperature, Soldering 10 Seconds	T _L	300	°C

Stresses greater than those listed under ABSOLUTE MAXIMUM RATINGS may cause permanent damage to the device. This is a stress rating only and functional operation of the device at these or any other conditions above indicated in the operational sections of this specification is not implied. Exposure to absolute maximum rating conditions for extended periods may affect reliability.

Recommended Conditions

Parameter	Symbol	Rating	Unit
Supply Voltage	V _{CC}	10 - 15	V
Oscillator	F _{OSC}	50 - 250	kHz

Typical Thermal Resistance

Package	θ _{JA}	θ _{JC}	Typical Derating
14L PDIP	85° C/W	40° C/W	11.7 mW/°C

Electrical Characteristics

Electrical Characteristics are guaranteed over full junction temperature range (0 to 105° C). Ambient temperature must be derated based on power dissipation and package thermal characteristics. Unless otherwise specified, the conditions of test are V_{CC} = 15 V; BOK = 3 V; OV = 0V; R_T = 680 Ω; C_T = 10 nF. To override UVLO, V_{CC} should be raised above 18 V prior to test.

Parameter	Symbol	Test Condition	Min	Typ	Max	Unit
Error Amplifier						
Input Voltage	V _{FB}	T _J = 25°C	2.465	2.500	2.535	V
Input Bias Current	I _{BIAS}			-0.1	-1	μA
Voltage Gain	A _{VOL}	2 ≤ V _{COMP} ≤ 4 V	65	90		dB
Transconductance	G _m			1		mA/mV
Unity Gain Bandwidth	GBW		0.8	1.2		MHz
Power Supply Rejection Ratio	PSRR	12 ≤ V _{CC} ≤ 18 V	60	70		dB
Output Sink Current	I _{COMPL}	V _{FB} = 2.7 V; V _{COMP} = 1.1 V	2	6		mA
Output Source Current	I _{COMPH}	V _{FB} = 2.3 V; V _{COMP} = 5 V	0.5	1.0		mA
Output Swing High	I _{COMPH}	V _{FB} = 2.3 V; R _L = 15 Ω to GND	5	5.5		V
Output Swing Low	I _{COMPL}	V _{FB} = 2.7 V; R _L = 15 Ω to V _{REG}		0.7	1.1	V

Electrical Characteristics (cont'd)

Electrical Characteristics are guaranteed over full junction temperature range (0 to 105° C). Ambient temperature must be derated based on power dissipation and package thermal characteristics. Unless otherwise specified, the conditions of test are $V_{CC} = 15\text{ V}$; $BOK = 3\text{ V}$; $OV = 0\text{ V}$; $R_T = 680\ \Omega$; $C_T = 10\text{ nF}$. To override UVLO, V_{CC} should be raised above 18 V prior to test.

Parameter	Symbol	Test Condition	Min	Typ	Max	Unit
5 V Regulator						
Output Voltage	V_{REG}	$I_{REG} = 1\text{ mA}$, $T_J = 25^\circ\text{C}$	4.90	5.00	5.10	V
Line Regulation	PSRR	$12 \leq V_{CC} \leq 18\text{ V}$		5	15	mV
Load Regulation		$1 \leq I_{REG} \leq 20\text{ mA}$		5	15	mV
Temperature Stability	TC_{REG}			0.2	0.4	mV/°C
Total Output Variation		Line, Load, Temperature	4.85		5.15	V
Long-Term Stability		Over 1,000 hrs at 25°C		5	25	mV
Output Noise Voltage	V_{NOISE}	$10 \leq f \leq 100\text{ kHz}$, $T_J = 25^\circ\text{C}$		50		μV
Maximum Source Current	I_{MAX}	$V_{REG} = 4.8\text{ V}$	30	120	180	mA
Oscillator						
Initial Accuracy	F_{OSC}	$T_J = 25^\circ\text{C}$	108	120	132	kHz
Voltage Stability		$12 \leq V_{CC} \leq 18\text{ V}$		0.2	1	%
Temperature Stability	TC_F	$T_{MIN} \leq T_J \leq T_{MAX}$		5		%
Amplitude	V_{OSC}	VRT/CT peak-to-peak		1.55		V
Upper Trip Point	V_H			2.80		V
Lower Trip Point	V_L			1.25		V
Discharge Current	I_{DSC}		7.50	8.70	9.50	mA
Duty cycle Limit		$R_T = 680\ \Omega$, $C_T = 10\text{ nF}$, $T_J = 25^\circ\text{C}$	46	50	54	%
Over-Temperature Shutdown	T_{OT}			140		°C
Soft Start Comparator						
SS Charge Current	I_{SS}	$V_{SS} \leq V_{RAMP}$	-4	-6	-10	μA
SS Discharge Current	$I_{DSC\ SS}$	$V_{SS} = 1\text{ V}$, $V_{OV} > 2.5\text{ V}$	2	8		mA
SS Lower Clamp	$V_{SS\ Low}$			0.6		V
RAMP High Level	V_{RAMPH}	$T_J = 25^\circ\text{C}$		2.15		V
RAMP Low Level	V_{RAMPL}	$T_J = 25^\circ\text{C}$		0.6		V
RAMP Levels TC		Note: RAMP waveform is the same as the RT/CT waveform, but level shifted down one diode drop		-2		mV/°C
RAMP Sink Current	I_{RAMPL}	$T_J = 25^\circ\text{C}$	-0.1	-0.2		mA
RAMP Source Current	I_{RAMPH}	$T_J = 25^\circ\text{C}$	1			mA
Propagation Delay to Output	t_{PB}			85	150	ns

Electrical Characteristics (cont'd)

Electrical Characteristics are guaranteed over full junction temperature range (0 to 105° C). Ambient temperature must be derated based on power dissipation and package thermal characteristics. Unless otherwise specified, the conditions of test are $V_{CC} = 15\text{ V}$; $BOK = 3\text{ V}$; $OV = 0\text{ V}$; $R_T = 680\ \Omega$; $C_T = 10\text{ nF}$. To override UVLO, V_{CC} should be raised above 18 V prior to test.

Parameter	Symbol	Test Condition	Min	Typ	Max	Unit
Housekeeping						
BOK UV Threshold	$V_{BOK\ UV}$	$V_{REG} = 5\text{ V}$	2.500	2.537	2.575	V
BOK UV Hysteresis Current	$I_{HYST\ BOK}$	$V_{BOK} = 2.6\text{ V}$	42	50	58	μA
BOK Input Bias Current	$I_{OFF\ BOK}$	$V_{BOK} = 2.4\text{ V}$		0.1	1.0	μA
OV Threshold	V_{OV}		2.50	2.80	3.10	V
OV Clear Threshold	V_{OVH}		3.80	4.00	4.50	V
OV Reset Threshold	V_{OVL}		1.10	1.75	2.20	V
OV Bias Current	$I_{BIAS\ OV}$	$V_{REG} = 5\text{ V}$, $V_{OV} \leq OV\ Threshold$ * For $V_{OV} > OV\ Reset\ Threshold$, see characteristic curve	-1	-0.2	1	μA
ACP Voltage	V_{ACP}	$I_{ACP} = 10\ \mu\text{A}$		1.3		V
ACP Voltage	V_{ACP}	$I_{ACP} = -10\ \mu\text{A}$		-1.2		V
LEN Charge Current	I_{LEN}	$I_{ACP} = 10\ \mu\text{A}$; $V_{LEN} = 0\text{ V}$	-30	-45	-65	μA
LEN Charge Current	I_{LEN}	$I_{ACP} = -10\ \mu\text{A}$; $V_{LEN} = 0\text{ V}$	-30	-50	-65	μA
Minimum Voltage for LEN Functionality	$V_{LEN\ MIN}$			3.6	4.5	V
LEN Logic Reset Voltage	V_{LEN}	This level reflects one diode drop of hysteresis from $V_{LEN\ min}$		3.0		V
LEN Regeneration Current	$I_{LEN\ rgn}$			-10		μA
LEN Clamp	V_{LEN}	$I_{ACP} = 5\ \mu\text{A}$	5.2	5.9	6.6	V
LEN Bias Current	$I_{BIAS\ LEN}$	$V_{LEN} = 5\text{ V}$, $I_{ACP} = 0\ \mu\text{A}$ * For LEN input current over full range, see characteristic curve.		8		μA
Current Sense Comparator						
Transfer Gain	A_{VISNS}	$-0.2 \leq V_{ISNS} \leq 0.8\text{ V}$	2.85	3.00	3.15	V/V
I_{SNS} Level Shift	V_{LS}	$V_{ISNS} = 0\text{ V}$		1.50		V
Maximum Input Signal		$V_{COMP} = +5\text{ V}$	1.00	1.08	1.20	V
Power Supply Rejection Ratio	PSRR	$12 \leq V_{CC} \leq 18\text{ V}$		70		dB
Input Bias Current	I_{BIAS}			-1	-10	μA
Propagation Delay to Output	t_{PB}			85	150	ns

Electrical Characteristics (cont'd)

Electrical Characteristics are guaranteed over full junction temperature range (0 to 105° C). Ambient temperature must be derated based on power dissipation and package thermal characteristics. Unless otherwise specified, the conditions of test are $V_{CC} = 15\text{ V}$; $BOK = 3\text{ V}$; $OV = 0\text{ V}$; $R_T = 680\ \Omega$; $C_T = 10\text{ nF}$. To override UVLO, V_{CC} should be raised above 18 V prior to test.

Parameter	Symbol	Test Condition	Min	Typ	Max	Unit
Under Voltage Lockout						
Startup Threshold	$V_{CC(ON)}$		12.5	14.0	15.8	V
Minimum Operating Voltage after Trun-on	$V_{CC(OFF)}$		7.3	8.0	8.5	V
Startup Current	I_{CC}	$V_{CC} = 12\text{ V}$; $V_{ACP} = V_{LEN} = 0\text{ V}$		2	10	μA
Startup Current	I_{CC}	$V_{CC} = 12\text{ V}$; $I_{ACP} = 5\ \mu\text{A}$		225	300	μA
Operating Supply Current	I_{CC}			12	20	mA
Maximum Operating Supply Voltage	$V_{CC\text{ Max}}$				18	V
Output Impedance to GND in UVLO State	Z_{OUT}	$V_{CC} = 6\text{ V}$		22.0		$\text{k}\Omega$
Output						
Output Low Level	V_{OL}	$I_{SINK} = 20\text{ mA}$		0.1	0.4	V
Output Low Level	V_{OL}	$I_{SINK} = 150\text{ mA}$		1.5	2.2	V
Output High Level	V_{OH}	$I_{SOURCE} = 20\text{ mA}$	13	13.5		V
Output High Level	V_{OH}	$I_{SOURCE} = 150\text{ mA}$	12	13		V
Rise Time	t_R	$C_L = 1\text{ nF}$		50	150	ns
Fall Time	t_F	$C_L = 1\text{ nF}$		50	150	ns
Maximum Duty Cycle	D_{MAX}		94	97	100	%
Minimum Duty Cycle	D_{MIN}		0			%

ASTEC reserves the right to make changes without further notice to any products described herein to improve reliability, function, or design. ASTEC does not assume any liability arising out of the application or use of any product or circuit described herein; neither does it convey any license under its patent rights or the rights of others. ASTEC products are not authorized for use as components in life support devices or systems intended for surgical implant into the body or intended to support or sustain life. Buyer agrees to notify ASTEC of any such intended end use whereupon ASTEC will determine availability and suitability of its products for the intended use. ASTEC and the ASTEC logo are trademarks of ASTEC (BSR) PLC.

ASTEC SEMICONDUCTOR

255 Sinclair Frontage Road • Milpitas, California 95035 • Tel. (408) 263-8300 • FAX (408) 263-8340