

# Infrared IrDA<sup>®</sup> Compliant Transceiver

## Technical Data

### Features

- **Low Cost Infrared Data Link**
- **Guaranteed to Meet IrDA Physical Layer Specifications**
  - 1 cm to 1 Meter Operating Distance
  - 30° Viewing Angle
  - 2.4 Kbd to 115.2 Kbd Data Rate
- **Daylight Cancellation**
- **Easily Implemented Direct Connection to Various I/O Chips**
- **Small Form Factor**
- **Several Lead and Shipping Configurations Available**
- **Excellent EMI Immunity (> 10 V/m)**

### Applications

- **Data Comm: Serial Data Transfer Between:**
  - Notebook Computers
  - Subnotebooks

- Desktop PCs
- PDA's
- Printers
- Other Peripheral Devices
- **Telecom:**
  - Modem, Fax, Pager, Phone
- **Industrial:**
  - Data Collection Devices
- **Medical:**
  - Patient and Pharmaceutical Data Collection

### Description:

The HSDL-1000 serial infrared module performs low cost, low power, point-to-point, through the air data transfer in a serial, half-duplex mode.

The module has been designed to the IrDA (Infrared Data Association) Physical Layer Specifications. The module is designed to

### HSDL-1000

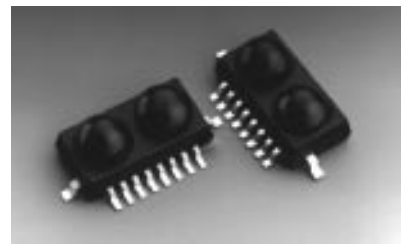

operate from 0 to 1 meter at a data rate of 115.2 Kbd per second at a 30° viewing angle.

The HSDL-1000 contains a high speed, high efficiency TS AlGaAs 875 nm LED, a PIN Silicon photodiode and an integrated circuit. The IC contains an LED driver, amplifiers and a quantizer.

The module is designed to interface directly with selected I/O chips that incorporate logic which performs pulse width modulation/demodulation.

### Schematic

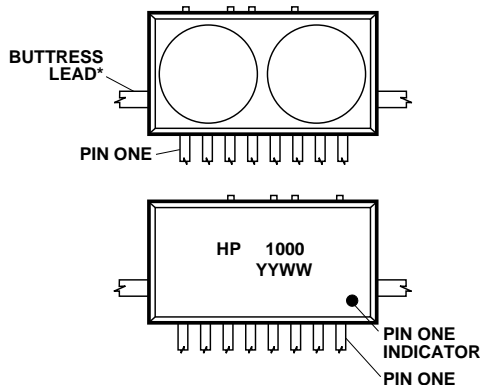

\* SIDE BUTTRESS LEADS ARE FOR MECHANICAL STABILITY AND SHOULD NOT BE CONNECTED TO ANY ELECTRICAL POTENTIAL.

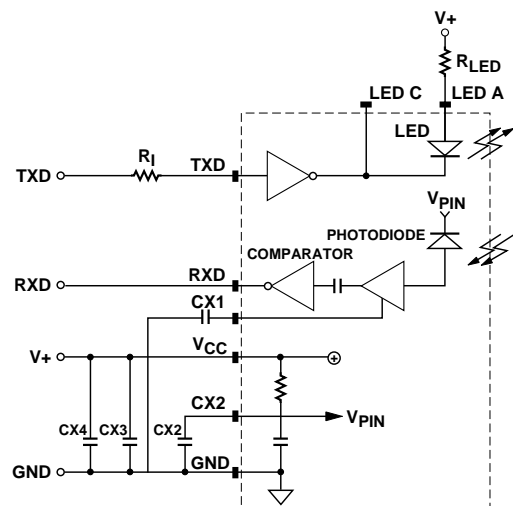





## Truth Table

Inputs		LED	Outputs	
TXD	EI <sup>[1]</sup>		LEDA	RXD
V <sub>IH</sub>	X	ON	Low	Low <sup>[2]</sup>
V <sub>IL</sub>	EI <sub>H</sub>	OFF	High	Low <sup>[2]</sup>
V <sub>IL</sub>	EI <sub>L</sub>	OFF	High	High

X = Don't care.

### Notes:

1. EI – received in band light intensity present at detector surface.
2. Logic Low is a pulsed response. A receiver output low state V<sub>OL</sub> (RXD) is not indefinitely maintained, but is instead a pulsed response. The output low state is maintained for a duration dependent on the incident bit pattern and the incident intensity (EI).

## Pinout

Pin	Description	Symbol
1	Daylight Cancellation Capacitor	CX1
2	PIN Bypass Capacitor	CX2
3	Supply Voltage	V <sub>CC</sub>
4	Receiver Data Output	RXD
5	Ground	Gnd
6	Transmitter Data Input	TXD
7	LED Cathode	LEDC
8	LED Anode	LEDA

## Absolute Maximum Ratings

Parameter	Symbol	Min.	Max.	Units	Conditions	Fig.
Storage Temperature	T <sub>S</sub>	-20	85	C		
Operating Temperature	T <sub>A</sub>	0	70	C		
Lead Solder Temperature			260	C	For 10 s (1.6 mm below seating plane)	Reflow Profile
Average LED Current	I <sub>LED</sub> (DC)		100	mA		
Repetitive Pulsed LED Current	I <sub>LED</sub> (PK)		500	mA	≤ 90 μs Pulse Width, ≤ 20% Duty Cycle	
Peak LED Current	I <sub>LED</sub> (RP)		1.0	A	≤ 2 μs Pulse Width, ≤ 10% Duty Cycle	
LED Anode Voltage	V <sub>LEDA</sub>	-0.5	7.0	V		
LED Cathode Voltage	V <sub>LEDC</sub>	-0.5	V <sub>LEDA</sub>	V		
Supply Voltage	V <sub>CC</sub>	0	7.0	V		
Transmitter Data Input Voltage	V <sub>TXD</sub>	-0.5	5.5	V		
Receiver Data Output Voltage	V <sub>RXD</sub>	-0.5	V <sub>CC</sub> + 0.5	V		

## Infrared Reflow Profile

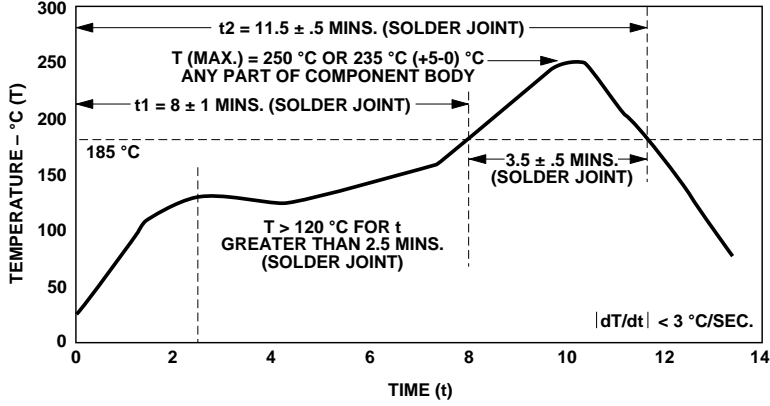

## Recommended Operating Conditions

Parameter	Symbol	Min.	Max.	Units	Conditions
Operating Temperature	$T_A$	0°	70°	C	
Supply Voltage	$V_{CC}$	4.5	5.5	V	
Logic High Transmitter Input Voltage	$V_{IH} (\text{TXD})$	2.5	5.5	V	
Logic Low Transmitter Input Voltage	$V_{IL} (\text{TXD})$	0.0	0.3	V	
Logic High Receiver Input Irradiance (870 nm)	$E_{IH}$	0.0036	500	mW/cm <sup>2</sup>	For in-band signals*
Logic Low Receiver Input Irradiance	$E_{IL}$		0.3	μW/cm <sup>2</sup>	For in-band signals*
LED (Logic High) Current Pulse Amplitude	$I_{LEDA}$	250		mA	For one metre links with daylight filters
Receiver Set-up Time		10		ms	For full sensitivity after transmitting
Signal Rate		2.4	116	Kp/s	
Ambient Light					See IrDA Serial Infrared Physical Layer Link Specification, Appendix A for ambient levels. See Rx TH+ section at the end of this data sheet also.

\*Note: An in-band optical signal is a pulse/sequence where the peak wavelength,  $\lambda_p$ , is defined as  $850 \text{ nm} \leq \lambda_p \leq 900 \text{ nm}$ , the pulse repetition rate, PRR, is defined as  $2.4 \text{ Kp/s} \leq \text{PRR} \leq 115.2 \text{ Kp/s}$  and the pulse width, PW, is defined as  $1.6 \text{ s} \leq \text{PW} \leq (3/16)/\text{PRR}$ .

## Electrical & Optical Specifications

Specifications hold over the Recommended Operating Conditions unless otherwise noted. Test Conditions represent worst case values for the parameters under test. Unspecified test condition can be anywhere in their recommended operating range. All typicals are at 25°C and 5V unless otherwise noted.

Parameter		Symbol	Min.	Typ.	Max.	Unit	Conditions	Fig.
Receiver Data Output Voltage	Logic Low <sup>[2]</sup>	$V_{OL} (RXD)^{[2,3]}$			0.4	V	$I_O = 0.3 \text{ mA}$ For In-Band $EI \geq 3.6 \text{ } \mu\text{W}/\text{cm}^2$ ; $\theta \leq 15^\circ$	
	Logic High	$V_{OH} (RXD)$	$V_{CC} - 0.5$			V	$I_O = -20 \text{ } \mu\text{A}$ , For In-Band $EI \leq 0.3 \text{ } \mu\text{W}/\text{cm}^2$	
Effective Detector Area				0.2		$\text{cm}^2$		
Transmitter Radiant Intensity	Logic Low	$IE_L$			0.3	$\mu\text{W}/\text{SR}$	$V_I \leq 0.3 \text{ V}$	
	Logic High Intensity	$IE_H$	44		250	$\text{mW}/\text{SR}$	$I_{LEDA} = 250 \text{ mA}$ , $V_I = 2.5 \text{ V}$ , $\theta \leq 30^\circ$	4, 6
					40	$\text{mW}/\text{SR}$	$I_{LEDA} = 250 \text{ mA}$ , $V_I = 2.5 \text{ V}$ ; $\theta > 60^\circ$	
	Peak Wavelength	$\lambda_p$		875		nm		6
Spectral Line Half Width	$\Delta\lambda^{1/2}$		35		nm		6	
Transmitter Viewing Angle	$\theta$	30		60	$^\circ$			7
Receiver	$\phi$	30			$^\circ$			
Transmitter Data Input Current	Logic Low	$I_{IL}(\text{TXD})$	-1.0		1.0	$\mu\text{A}$	$\text{Gnd} \leq V_I \leq 0.3 \text{ V}$	
	Logic High	$I_{IH}(\text{TXD})$	4.5			mA	$V_I = 2.5 \text{ V}$	1
LED Anode On State Voltage	$V_{ON} (\text{LEDA})$				2.50	V	$I_{LEDA} = 250 \text{ mA}$ , $T_j = 25^\circ\text{C}$	1, 3
LED Anode Off State Leakage	$I_{LK} (\text{LEDA})$				100	$\mu\text{A}$	$V_{LEDA} = V_{CC} = 5.5 \text{ V}$ , $V_I = 0.3\text{V}$	
Supply Current TXD High	ICC1				1.1	mA	$V_{CC} = 5.5$ , $V_I (\text{TXD}) = V_{IH}$ , $I_{LED} = 250 \text{ mA}$ , $EI = 0$	11
Supply Current RXD Low <sup>[2]</sup>	ICC2				13	mA	$V_{CC} = 5.5$ , $V_I (\text{TXD}) = V_{IL}$ , $EI = 500 \text{ mW}/\text{cm}^2$	1
Receiver Peak Sensitivity Wavelength	$\lambda_p$			880		nm		9

### Notes:

1. EI – received in band light intensity present at detector surface.
2. Pulsed Response – Logic Low is a pulsed response. A receiver output low state  $V_{OL} (RXD)$  is not indefinitely maintained but is instead a pulsed response. The output low state is maintained for a duration dependent on the incident bit pattern and incident intensity (EI).
3. The  $EI \geq 3.6 \text{ } \mu\text{W}/\text{cm}^2$  condition guarantees the IrDA minimum receiver sensitivity of  $4.0 \text{ } \mu\text{W}/\text{cm}^2$  while allowing for 10% light loss through a cosmetic window placed in front of the HSDL-1000. (See the Rx TH+ section at the end of this data sheet for information on receiver sensitivity over temperature, and in the presence of ambient light.)

## Switching Specifications

Specifications hold over the Recommended Operating Conditions unless otherwise noted. Test Conditions represent worst case values for the parameters under test. Unspecified test conditions can be anywhere in their recommended operating range. All typicals are at 25°C and 5V unless otherwise noted.

Parameter	Symbol	Min.	Typ.	Max.	Units	Conditions	Fig.
Transmitter Turn On Time			0.1		μs	I <sub>LED</sub> = 250 mA, 1.6 μs PW	13, 14
Transmitter Turn Off Time			0.4	1.0	μs		
Transmitter Rise Time				0.6	μs		
Transmitter Fall Time				0.6	μs		
Receiver Turn On Time			0.4		μs	EI = 3.6 μW/cm <sup>2</sup> , 1.6 μs PW	15, 16
Receiver Turn Off Time				5.4	μs	EI = 500 mW/cm <sup>2</sup> , 1.6 μs PW	
Receiver Rise Time			1.0		μs		
Receiver Fall Time			0.02		μs	EI = 3.6 μW/cm <sup>2</sup> , 1.6 μs PW	
Receiver Recovery Time				10	ms		

## Application Circuit

Component	Recommended Value
R <sub>I</sub>	300 Ohms ± 5%
R <sub>LED</sub>	8.0 Ohms maximum
CX1	0.22 μF ± 10%
CX2	0.4 μF minimum
CX3	0.10 μF ± 22%. Low inductance is critical
CX4	4.7 μF minimum. Larger value is recommended for noisy supplies or environments.

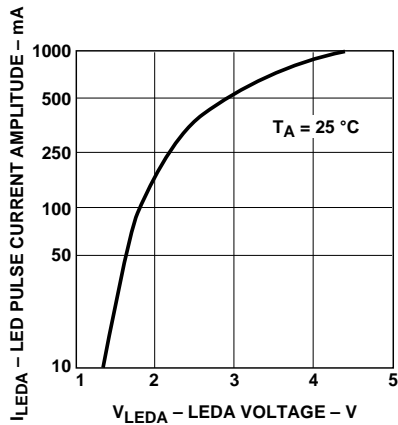

Figure 1. LED Pulse Current Amplitude vs. LEDA Voltage.

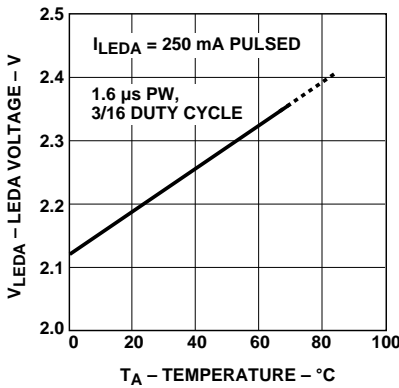

Figure 2. LEDA Voltage vs. Temperature.

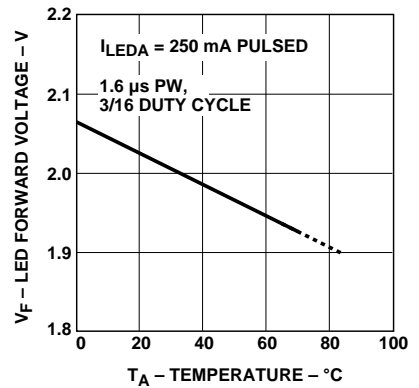

Figure 3. LED Forward Voltage vs. Temperature.

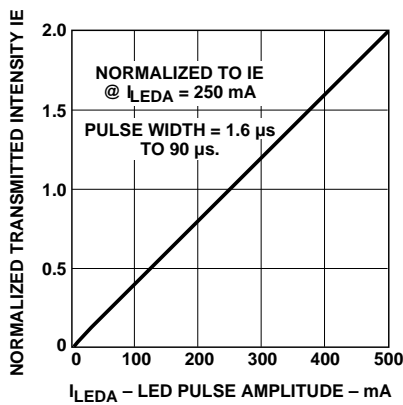

Figure 4. Transmitted Intensity vs. LED Pulse Amplitude.

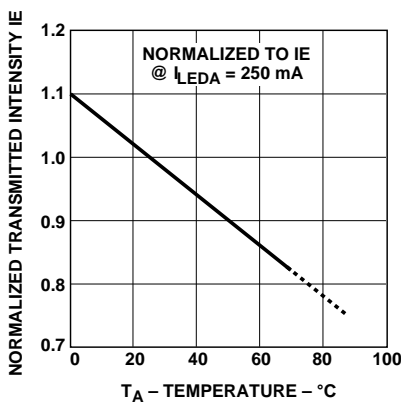

Figure 5. Transmitted Intensity vs. Temperature.

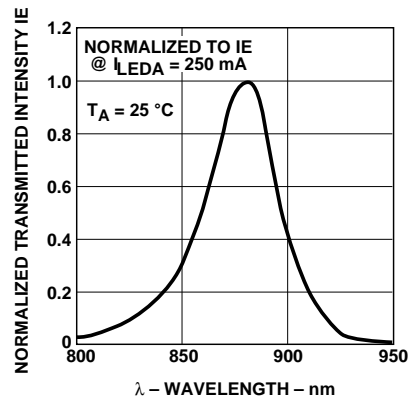

Figure 6. Transmitted Intensity vs. Wavelength.

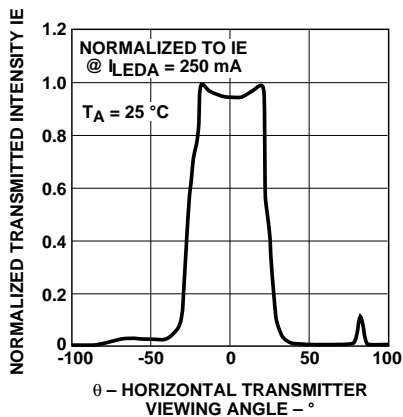

Figure 7. Transmitted Intensity vs. Horizontal Viewing Angle.

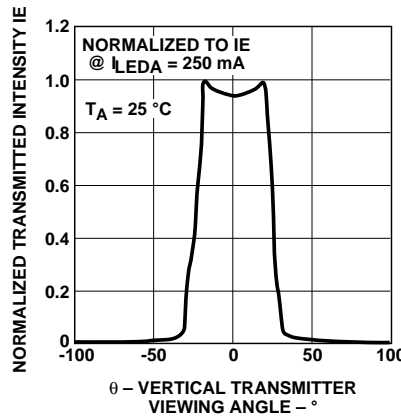

Figure 8. Transmitted Intensity vs. Vertical Viewing Angle.

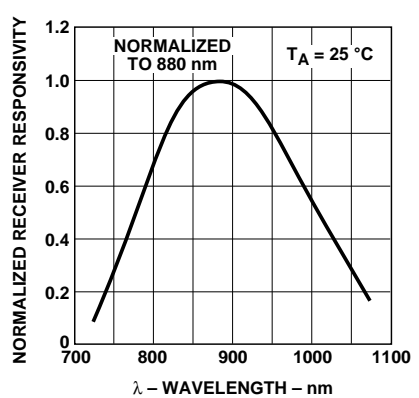

Figure 9. Receiver Responsivity vs. Wavelength.



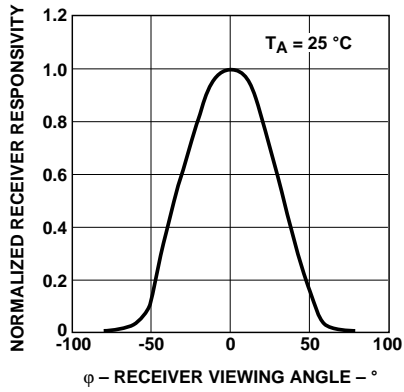

Figure 10. Receiver Responsivity vs. Viewing Angle.

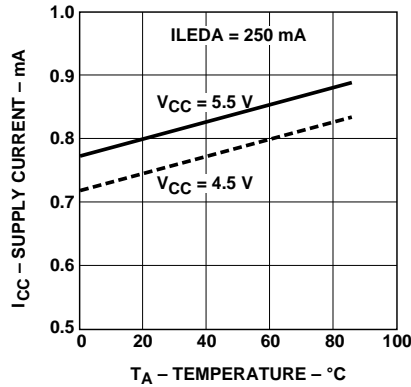

Figure 11. Supply Current vs. Temperature.

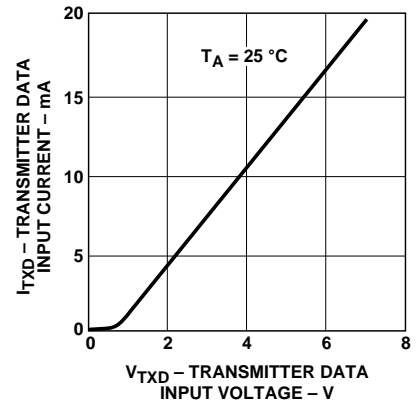

Figure 12. Data Input Current vs. Data Input Voltage.

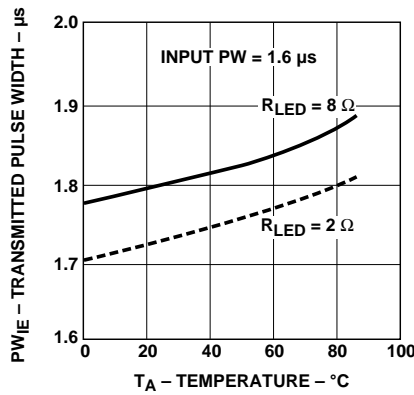

Figure 13. Transmitted Pulse Width vs. Temperature.

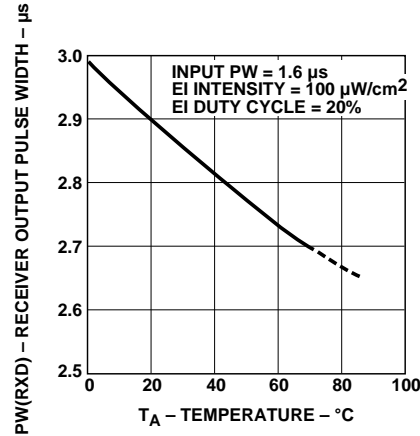

Figure 14. Transmitted Pulse Width vs. Temperature.

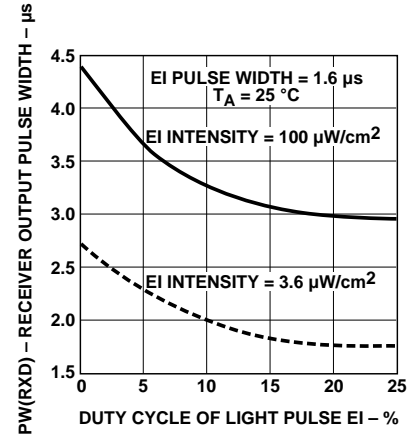

Figure 15. Receiver Output Pulse Width vs. Duty Cycle of Received Signal.

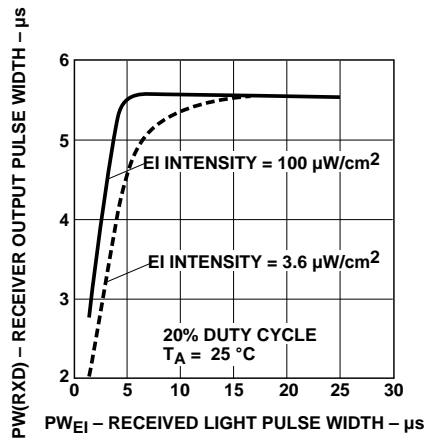

Figure 16. Receiver Output Pulse Width vs. Received Light Pulse Width.

### Rx TH+ (Receiver On-Threshold)

The maximum receiver on-threshold is equivalent to the minimum receiver sensitivity. Both are terms for the amount of light signal which must be present at the HSDL-1000 detector in order to trigger a low pulse on the receiver output (RXD). The IrDA Physical Layer Specification requires a minimum receiver sensitivity of  $4.0 \mu\text{W}/\text{cm}^2$ , at a Bit Error Rate of  $10^{-9}$ , and in the presence of the 10 klux of sunlight, 0-1000 lux of fluorescent

light, or 0-1000 lux of incandescent light. The fluorescent and incandescent specifications require minimum receiver sensitivity with 1000 lux incident onto the horizontal surface of the IR link. The resulting amount of fluorescent or incandescent light actually reaching the detector surface may vary between 0 and 500 lux depending upon the design of the housing around the HSDL-1000 module.

The HSDL-1000  $V_{OL}(RXD)$  specification guarantees a maximum receiver on-threshold of  $EI = 3.6 \mu\text{W}/\text{cm}^2$ , at a  $BER \leq 10^{-9}$ , and  $T_A = 0-70^\circ\text{C}$ . The  $EI = 3.6 \mu\text{W}/\text{cm}^2$  threshold guarantees the IrDA minimum receiver sensitivity of  $4.0 \mu\text{W}/\text{cm}^2$ , while allowing for 10% light loss through a cosmetic window placed in front of the HSDL-1000. The  $EI = 3.6 \mu\text{W}/\text{cm}^2$  threshold also guarantees receiver sensitivity with 10 klux of sunlight, 0-500 lux fluorescent light, or 0-500 lux of incandescent light incident on the HSDL-1000 detector surface.

### HSDL-1000 Reliability Test Results

Test Name	MIL-STD-883 Reference	Test Conditions	Units Tested	Total Failed
Solder Heat (IR Profile)		See absolute profile	60	0
Solder Heat Resistance		3 times thru IR Profile + 20 Temp. Cycles	60	0
Solder Rework Cycle		Solder iron tip temp. $370^\circ\text{C}/700^\circ\text{F}$ Time per lead 1 second # of rework cycles = 4	17	0
Temperature Cycle	1010	$-40^\circ\text{C}$ to $+100^\circ\text{C}$ , Dwell = 15 Minutes Transfer = 5 Minutes		
		20 Cycles	120	0
		100 Cycles	120	0
Power Temp. Cycle		$-40^\circ\text{C}/+100^\circ\text{C}$ , Dwell = 15 minutes, Transfer = 5 Minutes, $V_{CC} = 5 \text{ Vdc}$ , $I_f = 100 \text{ mAdc}$ , LED On/Off = 1 Second Total Cycles = 35	60	0
Mechanical Shock	2002 Condition B	2 Blows each X1, X2, Y1, Y2, Z1, Z2 1500 G's, 0.5 msec Pulse	10	0
Vibration Variable Frequency	2007 Condition A	(4) 4 Minute Cycles, X, Y, Z at 50 G's Min., 20 to 2,000 Hz	10	0
Resistance to Solvents	2015	3 one minute immersion Brush after solvent	20	0
High Temp. Operating Life		$T_A = 70^\circ\text{C}$ , $I_f = 100 \text{ mAdc}$ , $V_{CC} = 5 \text{ Vdc}$ , Time = 500 hours	60	0
Low Temp. Operating Life		$T_A = 0^\circ\text{C}$ , $I_f = 100 \text{ mAdc}$ , $V_{CC} = 5 \text{ Vdc}$ Time = 500 hours	60	0
Wet Operating Life		$T_A = 35^\circ\text{C}$ , R.H. = 85% $I_f = 100 \text{ mAdc}$ $V_{CC} = 5 \text{ Vdc}$ , Time = 500 hours	60	0
ESD - Human Body Model	3015	RI = 1500 Ohms, C = 100 $\mu\text{F}$ Level = 4000 V	10	0
ESD - Machine Model	EIAJ	Rload = 0 Ohms, C = 200 $\mu\text{F}$ Level = 300 V	10	0

**Note:** At the time of this publication, Light Emitting Diodes (LEDs) that are contained in this product are regulated for eye safety in Europe by the Commission for European Electrotechnical Standardization (CENELEC) EN60825-1. Please refer to Application Briefs I-008, I-009, I-015 for more information.