

MITSUBISHI <LINEAR ICs>
M51206TL,FP

VOLTAGE COMPARATOR

DESCRIPTION

The M51206 is a semiconductor integrated circuit for a voltage comparator that operates at a single power supply. Especially the M51206 has superiority as to characteristics of input current (high input resistance) and fits to wide ranged applications, for example CR timer, etc. M51206TL, FP's package is a mini SIP and FLAT package, therefore can use very easily.

FEATURES

- Low input current 15nA (typ.)
- Built-in zener diode for stabilization of supply voltage between supply voltage terminal and GND terminal 5.6V (typ.)
- Capable of directly driving a relay or lamp
- High output breakdown voltage 30V (max.)

APPLICATION

Voltage comparator, CR timer, electric shutter, time delay circuit, oscillator (square wave).

RECOMMENDED OPERATING CONDITION

Rated supply voltage 12V ($R_d=1k\Omega$)

PIN CONFIGURATION (TOP VIEW)

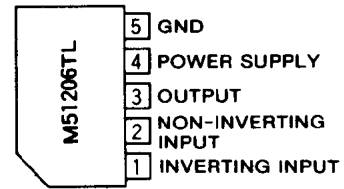

Outline 5P5T

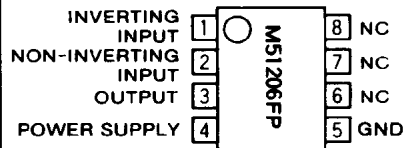

Outline 8P2S-A

NC : NO CONNECTION

EQUIVALENT CIRCUIT

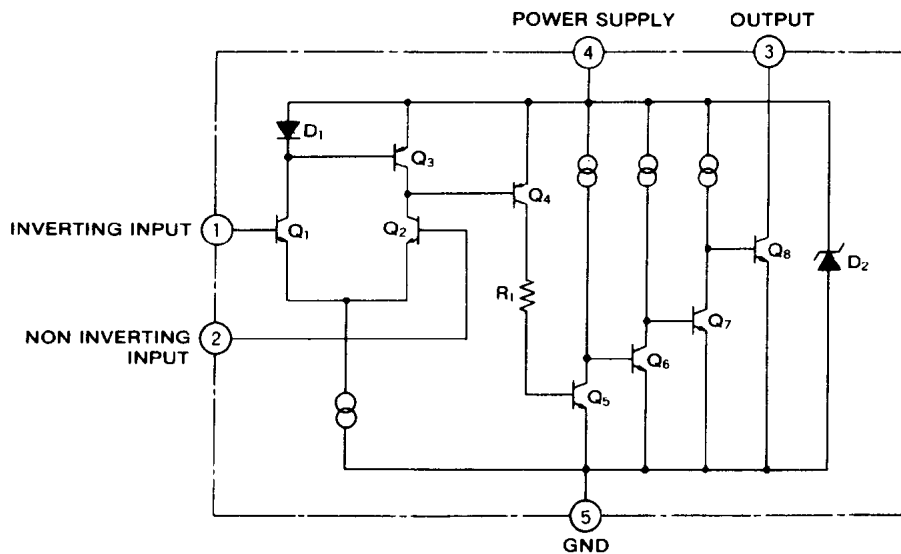

VOLTAGE COMPARATOR

ABSOLUTE MAXIMUM RATINGS ($T_a=25^\circ\text{C}$, unless otherwise noted)

Symbol	Parameter	Conditions	Ratings	Unit
I_{CC}	Circuit current		20	mA
V_{IN}	Input voltage		$V_{(D)}$ *	V
I_{OL}	Output drive current	Output saturated	60	mA
V_{OH}	Output drive voltage		30	V
P_d	Power dissipation		180(M51206TL)	mW
			300(M51206FP)	
K_θ	Thermal derating	$T_a \geq 25^\circ\text{C}$	1.8(M51206TL)	mW/ $^\circ\text{C}$
			3.0(M51206FP)	
T_{opr}	Operating temperature		$-20 \sim +75$	$^\circ\text{C}$
T_{stg}	Storage temperature		$-40 \sim +125$	$^\circ\text{C}$

*Voltage at Pin ④

ELECTRICAL CHARACTERISTICS ($T_a=25^\circ\text{C}$, R_d : dropper resistor)

Symbol	Parameter	Test conditions		Limits			Unit
		V_{CC} (V)		Min	Typ	Max	
$V_{(D)}$	Zener voltage range	12.0	$R_d=1\text{k}\Omega$	5.0	5.6	7.0	V
V_{IN}	Input voltage range	12.0	$R_d=1\text{k}\Omega$	0.8		$V_{(D)}-0.2$	V
$I_{IN(1)}$	Input current at Pin ①	12.0	$R_d=1\text{k}\Omega$		15	75	nA
$I_{IN(2)}$	Input current at Pin ②	12.0	$R_d=1\text{k}\Omega$		15	75	nA
I_{CC}	Circuit current ($V_{CC} < V_{(D)}$)	5.0	$R_d=0\Omega$		1.8	2.4	mA
V_{IO}	Input offset voltage	12.0	$R_d=1\text{k}\Omega$	-20	-1.4	20	mV
V_{OL}	Output saturation voltage	12.0	$R_d=1\text{k}\Omega, R_L=200\Omega$		0.3	0.6	V
t_{PLH}	Output "L-H" propagation delay time	12.0	$R_d=1\text{k}\Omega$		1		μs
t_{PHL}	Output "H-L" propagation delay time				10		μs

TYPICAL CHARACTERISTICS ($T_a=25^\circ\text{C}$, unless otherwise noted)

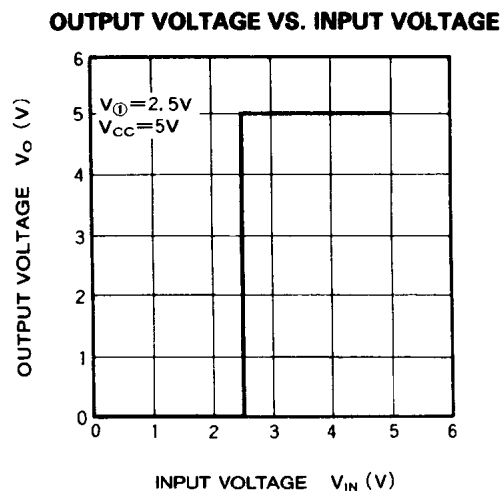
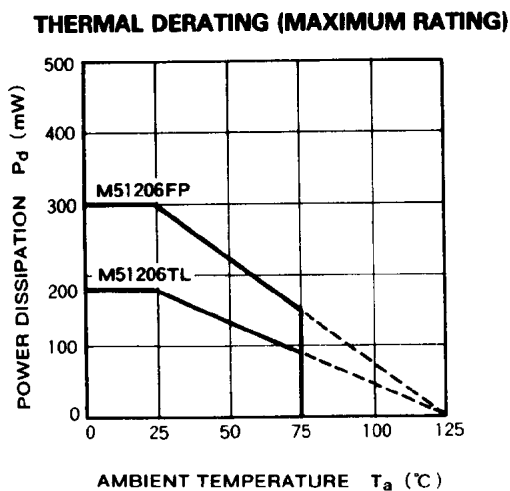

VOLTAGE COMPARATOR

INPUT CURRENT VS. INPUT VOLTAGE

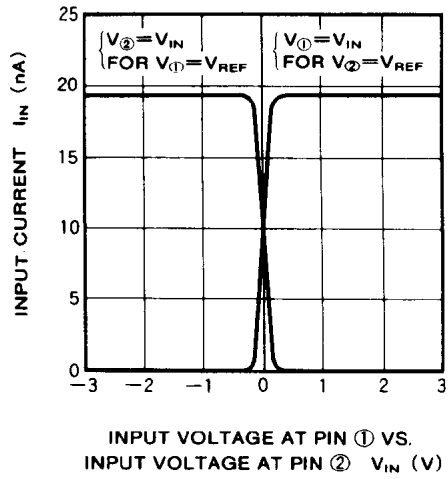

ZENER VOLTAGE VS. AMBIENT TEMPERATURE

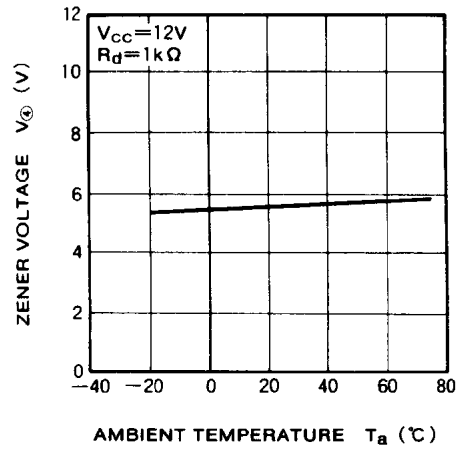

CIRCUIT CURRENT VS. AMBIENT TEMPERATURE

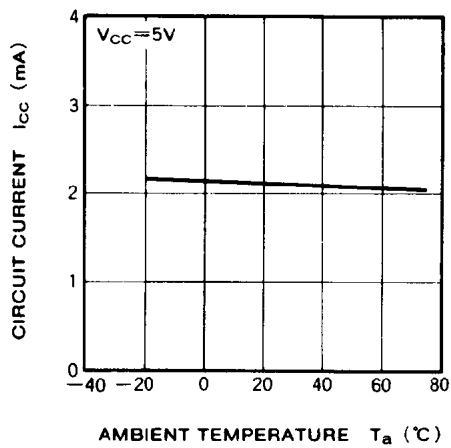

DROPPER RESISTOR (R_d) SELECTION GRAPH

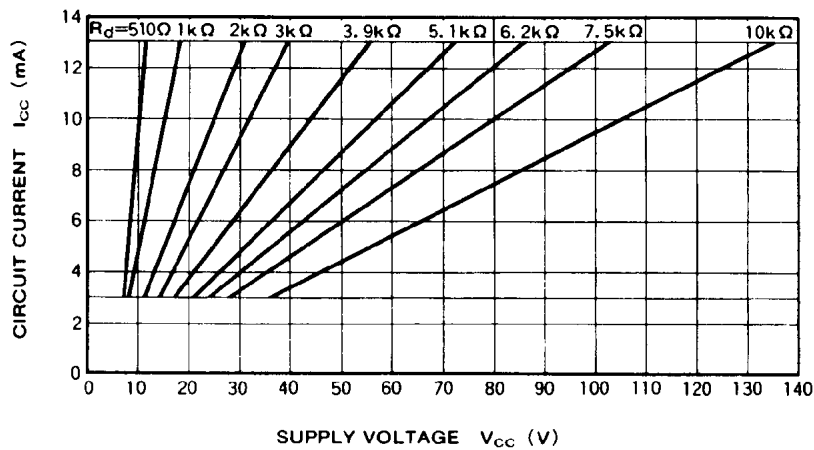

APPLICATION EXAMPLES

(1) Voltage comparator

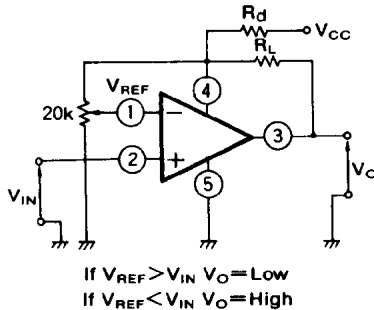

(2) CR Timer

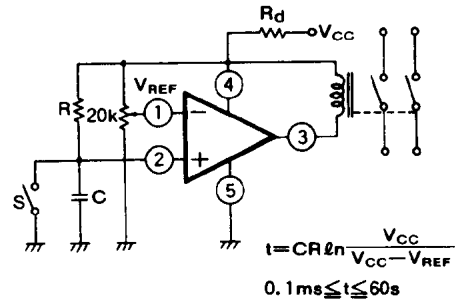

(3) Window comparator (alarm circuit)

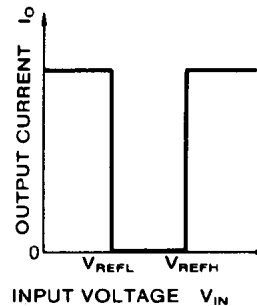
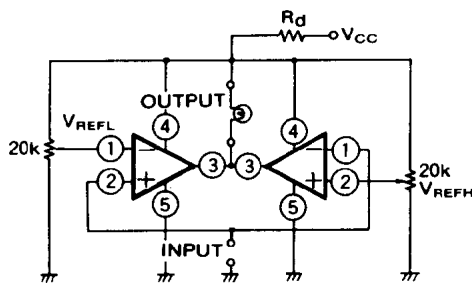

(4) Time delay circuit

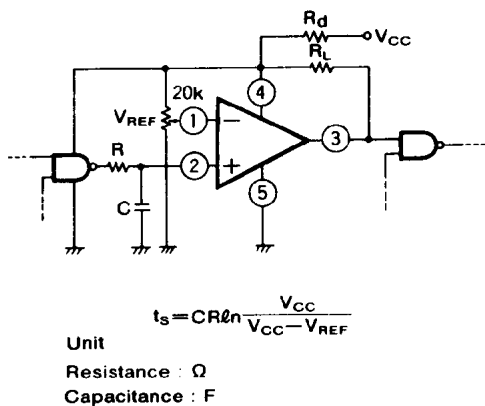

PRECAUTIONS FOR USE

1. Paying much attention is necessary for fear that the M51206TL,FP may flow large current and reach to destroy because of the structure when the terminals of V_{CC} and GND of the M51206TL,FP is connected wrong position each other.
2. Output is "open collector" and a loading resistor is not included. Connect a loading resistor to stabilize operation, in case of driving a next stage.
3. Care should be taken not to apply over 5(V) directly to the terminals between Pin ④ and Pin ⑤. Connect a dropper resistor (R_d) in series to Pin ④ in case of applying over 5(V) between Pin ④ and Pin ⑤.