

Integrated CMOS Image Sensor with on-chip ADC.

**DISTINCTIVE CHARACTERISTICS**

- Standard image format: 160 x 120
- 164 x 124 pixel array
- Variable frame rate (2 fps - 60 fps)
- On-chip 8-bit A/D convertor
- 8-bit and 4-bit conversion modes
- 8-wire and 4-wire parallel data output modes
- Reduced flicker operation with 50Hz and 60Hz mains frequencies
- 2 serial data output modes
- Automatic exposure and gain controller
- Automatic black level calibration
- Options selectable via serial interface

**GENERAL DESCRIPTION**

VV5300 is a highly-integrated CMOS image sensing device. In addition to a 160 x 120 pixel image sensor array, the device includes on-chip circuitry to drive and sense the array.

VV5300 features electronic exposure and gain control over a wide range, enabling the use of a single fixed-aperture lens.

The output stage of the sensor contains a successive approximation circuit which performs analogue-to-digital conversion of the photodiode array to produce 8-bit or 4-bit pixel data.

A bi-directional 2-wire serial communications interface allows the device to be configured and its operating status monitored. The status information may also be multiplexed onto the digital output bus.

The primary image size is 160 x 120 but border pixels/lines can be enabled to give an effective image size of 164 x 124.

**BLOCK DIAGRAM**

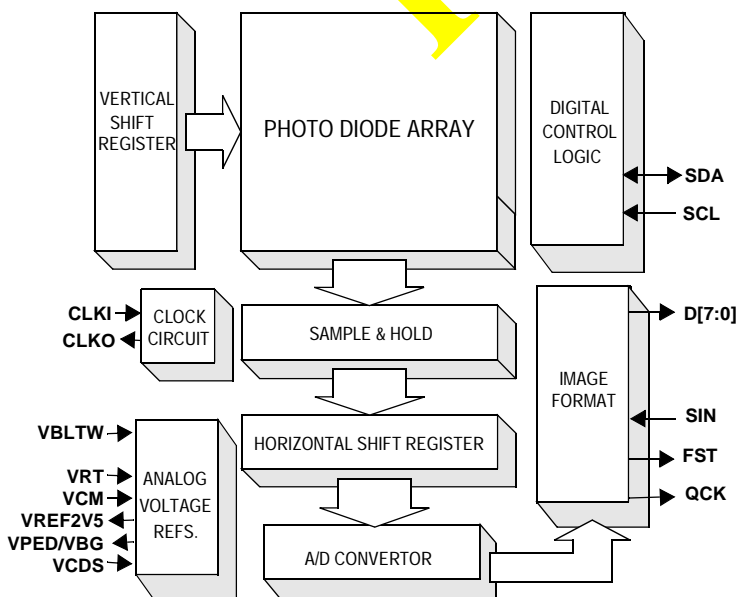

Pixel Resolution	160 x 120
Pixel Size	12µm x 12µm
Array Size	1.92mm x 1.44mm
Power Supply	5v +/-10%
Min.illumination	0.1 Lux
Power	175 mW (Typ.)
S/N	36 dB (Typ.)
Exposure control	Automatic (25000:1)
Temperature	-20°C to +70°C

## Main Features

On-chip 8-bit successive approximation analogue-to-digital convertor with 8-wire, 4-wire parallel and two serial data output modes.

The default image format is 160x 120. Extra border pixel/lines can be enabled to give an image size of 164 x 124. Digital pixel data coding assigns 10<sub>H</sub> as black and F0<sub>H</sub> as white. Other codes specify line sync and frame sync periods.

The VV5300 frame rates can be integer multiples of the mains supply frequencies used worldwide, i.e. 50Hz and 60Hz. This ensures reduced flicker operation of the sensor

All VV5300 operating modes and system status information can be accessed via a two wire bidirectional serial interface.

VV5300 features an automatic electronic exposure algorithm that enables the use of a single fixed-aperture lens. Automatic gain control enhances operation under low light conditions.

Automatic black level control ensures consistent picture quality across the whole range of operating conditions. Extensive use of automated operation and on chip references means that only a small number of passive components are needed to realise a complete video camera.

On-chip voltage references simplifies the support circuitry and maintains device stability over a wide range of operating conditions.

*This device is also available with bayer pattern colour filters (VV6300), see seperate datasheet.*

## Exposure Control

With automatic exposure control selected VV5300 uses a complex algorithm to automatically set the exposure value for the current scene. When combined with clock control and gain control the VV5300 can operate over a very wide range of illumination levels.

Where direct control of the exposure is required the exposure value can be directly selected by writing to the appropriate registers via the serial interface.

## Clock Control

The system clock can be divided down internally to extend the operating range of VV5300 by allowing longer exposure times. The clock divisor can be varied from 2 to 16 in times two steps i.e there are 4 different values. Note: changing the system clock divisor modifies the pixel and frame rate.

## Gain Control

If the image is too dark and the exposure is already close to its maximum, VV5300 will increase the system gain.

Gain can be varied from x1 to x8 in times two steps i.e there are 4 different gain settings. If the scene is too dark and integration period has almost reached its maximum value the gain value is incremented by one step (i.e. doubled). If the gain setting changes the exposure value is automatically set to half the maximum integration period. The exposure controller then increases the exposure value as necessary.

Similarly if the image is too bright and the integration period is short then gain will be reduced by one step (i.e. divide by two). As before, the exposure value is set to half the maximum integration period. The exposure controller can then adjust the exposure value as necessary to provide a correctly exposed image.

Device Pinout

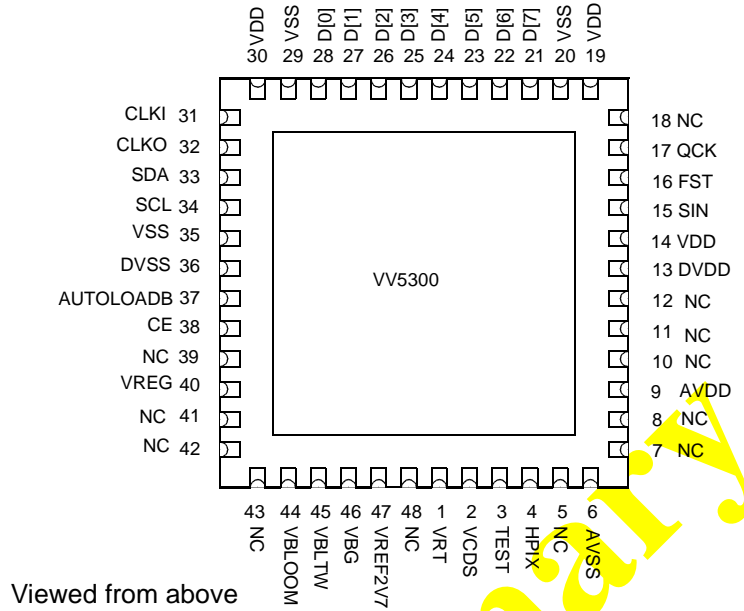

Pad List

Pin	Name	Type	Description
<b>POWER SUPPLIES</b>			
6	AVSS	GND	Analogue ground
9	AVDD	PWR	Analogue power
13	DVDD	PWR	Digital power
14	VDD	PWR	Power
19	VDD	PWR	Power
20	VSS	GND	Ground
29	VSS	GND	Ground
30	VDD	PWR	Power
35	VSS	GND	Ground
36	DVSS	GND	Ground
<b>ANALOGUE OUTPUTS</b>			
1	VRT	IA	Pixel reset voltage

Pin	Name	Type	Description
2	VCDS	IA	Voltage reference
3	TEST	IA	Analogue test
40	VREG	IA	Reference voltage input
44	VBLOOM	OA	Internal reference voltage
45	VBLTW	IA	Bitline test white reference
46	VBG	OA	Internally generated bangap reference voltage 1.22V
47	VREF2V5	OA	Internally generated reference voltage 2.5V
<b>DIGITAL OUTPUTS</b>			
16	FST	OD	Frame start. Synchronises external image capture.
17	QCK	OD	Pixel sample clock. Qualifies video output for external image capture.
25-28	D[3:0]	BI↓	Parallel 4-bit databus. D[0] serial data bus.
21-24	D[7:4]	OD↓	Parallel 4-bit databus.
<b>DIGITAL CONTROL SIGNALS</b>			
34	SCL	BI↑	Serial bus clock (bidirectional, open drain)
33	SDA	BI↑	Serial bus data (bidirectional, open drain)
37	AUTOLO ADB	ID↓	Enable autoload from EEPROM
38	CE	ID↑	Chip enable
4	HPIX	ID↓	Hold pixel value.
15	SIN	ID↓	Frame Timing reset(Soft reset)
<b>SYSTEM CLOCKS</b>			
31	CLKI	ID	Oscillator input.
32	CLKO	OD	Oscillator output.

OA - Analogue output  
 OD - Digital output  
 BI - Bidirectional  
 OD↓ – Digital output with internal pull-down

A - Analogue input  
 D - Digital input  
 ID↑ – Digital input with internal pull-up

## SPECIFICATIONS

### Package Details

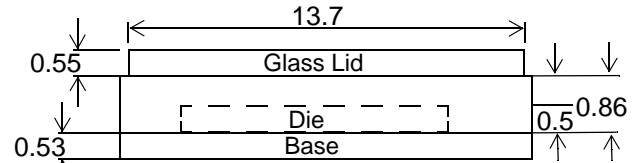
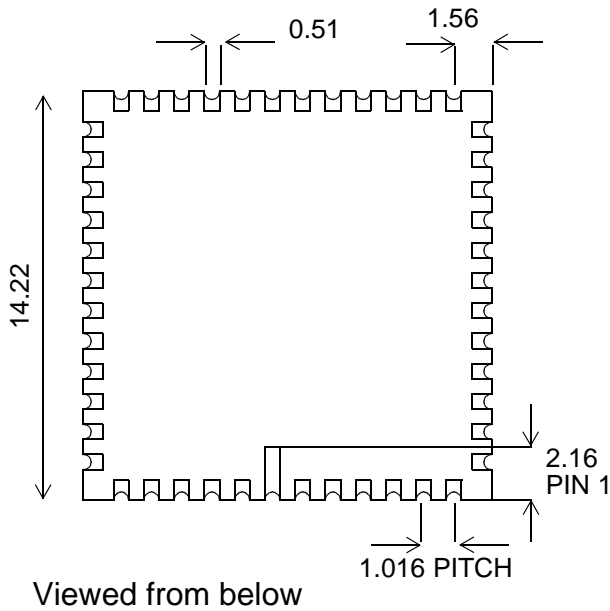

Viewed from side

The optical array is centred within the package to a tolerance of  $\pm 0.2$  mm, and rotated no more than  $\pm 0.5^\circ$

Tolerances on package dimensions  $\pm 10\%$

Glass lid placement is controlled so that no package overhang exists.

All dimensions in millimetres +/-

### Spectral Response

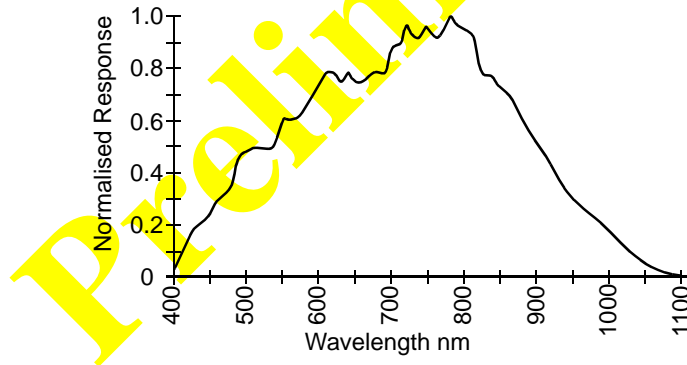

## Absolute Maximum Ratings

Parameter	Value
Supply Voltage	-0.5 to +7.0 volts
Voltage on other input pins	-0.5 to $V_{DD} + 0.5$ volts
Temperature under bias	-15°C to 85°C
Storage Temperature	-30°C to 125°C
Maximum DC TTL output Current Magnitude	10mA (per o/p, one at a time, 1sec. duration)

Note: Stresses exceeding the Absolute Maximum Ratings may induce failure. Exposure to absolute maximum ratings for extended periods may reduce reliability. Functionality at or above these conditions is not implied.

## DC Operating Conditions

Symbol	Parameter	Min.	Typ.	Max.	Units	Notes
$V_{DD}$	Operating supply voltage	4.75	5.0	5.25	Volts	
$V_{IH}$	Input Voltage Logic "1"	2.4		$V_{DD}+0.5$	Volts	
$V_{IL}$	Input Voltage Logic "0"	-0.5		0.8	Volts	
$T_A$	Ambient Operating Temperature	0		70	°C	Still air

## AC Operating Conditions

Symbol	Parameter	Min.	Typ.	Max.	Units	Notes
CKIN	Crystal frequency		14.318		MHz	1
SCL	Serial Data Clock			100	KHz	2

1. Pixel Clock =  $CKIN/2$
2. Serial Interface clock must be generated by host processor.

## Electrical Characteristics

Symbol	Parameter	Min.	Typ.	Max.	Units	Notes
$I_{DCC}$	Digital supply current		10		mA	1
$I_{ADD}$	Analog supply current		25		mA	1

Typical conditions,  $V_{DD} = 5.0$  V,  $T_A = 27^\circ\text{C}$

Symbol	Parameter	Min.	Typ.	Max.	Units	Notes
$I_{DD}$	Overall supply current		35		mA	1
$V_{REF2V7}$	Internal voltage reference		2.700		Volts	
$V_{BG}$	Internal bandgap reference		1.22		Volts	
$V_{OH}$	Output Voltage Logic "1"	2.4			Volts	$I_{OH} = 2\text{mA}$
$V_{OL}$	Output Voltage Logic "0"			0.6	Volts	$I_{OL} = -2\text{mA}$
$I_{ILK}$	Input Leakage current	-1			$\mu\text{A}$	$V_{IH}$ on input
				1	$\mu\text{A}$	$V_{IL}$ on input

Typical conditions,  $V_{DD} = 5.0\text{ V}$ ,  $T_A = 27^\circ\text{C}$

1. Digital and Analogue outputs unloaded - add output current.

Preliminary

## Operating Characteristics

Parameter	min.	typ.	max.	units	Note
Dark Current Signal		50		mV/Sec	Modal pixel voltage due to photodiode leakage under zero illumination with Gain=1 ( $V_{dark} = (V_{t1} - V_{t2}) / (t1 - t2)$ ), calculated over two different frames
Sensitivity		6		V/Lux·Sec	$V_{Ave} / \text{Lux} \cdot 10\text{ms}$ , where Lux gives 50% saturation with Gain=1 and Exposure=10ms
Min. Illumination		0.1		Lux	Standard CCIR clock
Shading		TBA		%	Variance of $V_{ave}$ over eight equal blocks at 66% saturation level illumination
Random Noise		-36		dB	RMS variance of all pixels, at 66% saturation, over four frames
Smear		TBA		%	Ratio of $V_{ave}$ of the area outside a rectangle 25 lines high illuminated at $500 \times V_{50\%}$ level to $V_{Ave}$ of the rectangle
Flicker		TBA		%	Variation of $V_{ave}$ of one line from field to field at 66% saturation level illumination
Lag		TBA		%	Average residual signal with no illumination in the field following one field of 66% sat. illumination
Blooming		TBA			Ratio of spot illumination level that produces $0.1 \times V_{sat}$ output from immediately around the spot to the $V_{sat}$ spot illumination level (pin-hole target)

Note: Devices are normally not 100% tested for the above characterisation parameters, other than Dark Current Signal (see Blemish Specification below).

All voltage ( $V_A$ ,  $V_{ave}$ ,  $V_{sat}$ ,  $V_{xx\%}$ ) measurements are referenced to the black level,  $V_{black}$ , and spot blemishes are excluded (see Blemish Specification below).  $V_{xx\%}$  refers to the output that is xx% of saturation, that is peak white

### Test Conditions

The sensor is tested using the example support circuit illustrated later in this document. Standard imaging conditions used for optical tests employ a tungsten halogen lamp to uniformly illuminate the sensor (to better than 0.5%), or to illuminate specific areas. A neutral density filter is used to control the level of illumination where required.

Illumination Colour Temp.	3200° K
Clock Frequency	14.318MHz
Exposure	Maximum
Gain	x1
Auto. Gain Control (AGC)	Off



## Blemish Specification

A Blemish is an area of pixels that produces output significantly different from its surrounding pixels for the same illumination level. The definition of a Blemish Pixel varies according to testing conditions as follows:

Test	Exposure	Illumination	Blemish Pixel output definition
1 - Black Frame	Minimum	Black	Differing more than $\pm 100$ mV. from modal value.
2 - Dark Current	Maximum	Black	Output more than three times the modal value (see Dark Current Signal above).
3 - Pixel Variation	Mid range	66% Sat.	Differing more than $\pm 35$ mV from modal value. Note: The mode of pixel values must be within $\pm 70$ mV of 66% of $V_{sat}$ for all devices.

**Note:** Gain is set to Minimum and Correction set to Linear for all tests; measurement of blemishes for Test 3 is conducted under standard illumination (see above), set to produce average output of 66% saturation level.

The blemish specification is then defined as follows:

Max. No. of Blemishes	Notes
4	Unconnected single pixels
1	Of up to four connected pixels (2x2 max.)

NB, pixel blemishes may occur anywhere on the array.

### System Clock Generation

VV5300 generates a system clock when a quartz crystal or ceramic resonator circuit is connected to the CLKI and CKO pins. The device can also be driven directly from an external clock source driving CLKI.

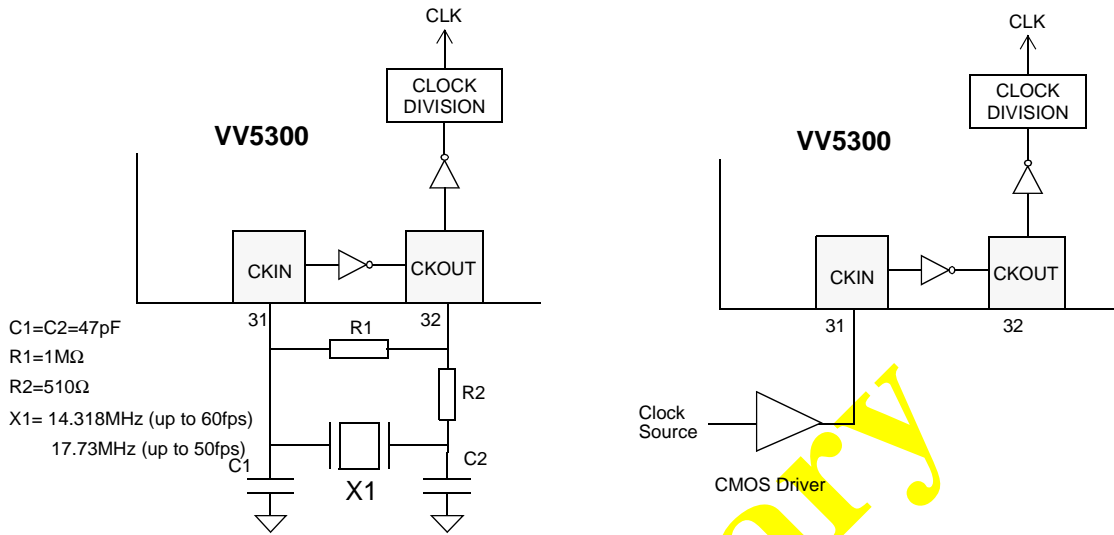

### Camera Clock Source

For greater flexibility the input frequency can be divided by 2, 4, 8 or 16 to select the pixel clock frequency. Two bits in the clock division register in the serial interface select the input clock frequency divisor. The table below gives the different frame rates that can be selected, when CLKI = 14.318MHz, for each divisor. The default clock divisor setting is a divide by 2. To achieve maximum frame rates data is converted at 4 bit resolution.

CLKI (MHz)			Divisor	Pixel Freq. (kHz)	Frame rate <sup>1</sup> (fps)	Comments
14.318	0	0	2	1790	59.98	default
14.318	0	1	4	895	29.99	
14.318	1	0	8	448	15.01	
14.318	1	1	16	224	7.5	

### Clock Division (60Hz Video Mode)

1. Approximate frame rate. Assumes 160 x 120 image format, parallel data output and 4 bit data conversion

### Image Format

VV5300 has a single output image size, 160 x 120 pixel. The image size can be modified by asserting the “enable borders” serial interface register bit, (Setup1, [001\_0001<sub>2</sub>]). The extended image size is 164 x 124 pixels. The default image format is 160 pixels by 120 lines.

Enable borders	Image size (column x row)	Comment
0	160 x 120	default
1	164 x 124	

### Image Format Selection

The diagram below shows the relationship between the default 160 x 120 pixel image and the extended 164 x 124 pixel format. A border, 2 pixels wide is enabled around the basic array.

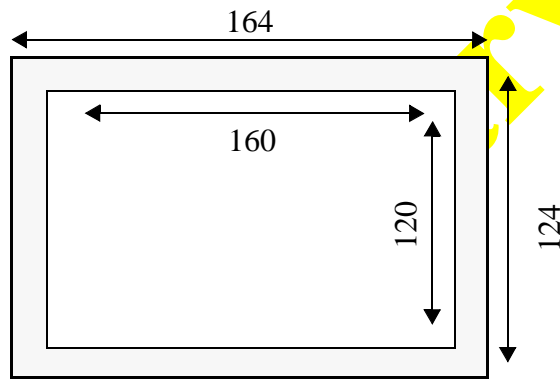

Output Image Dimensions

## Frame Timing

The VV5300 frame rate depends upon:

- (i) the frequency of the clock input (CLKI)
- (ii) the ADC conversion accuracy
- (ii) the internal clock divisor chosen.

Users can set their own values for CLKI, the ADC conversion rate and also the clock divisor setting, subject to achieving a frame rate up to 60 frames/sec.

The frame rate is determined in the following way:

An example is given with a clock input of 14.318MHz, 160 x120 image format, 8 bit ADC conversion rate and a clock divisor of 4.

1. Determine clock input (CLKI) frequency - 14.318MHz

2. Pixel period = (Divisor x 8) / CLKI

Example: Pixel period =  $(4 \times 8) / 14.318\text{MHz} = 2.235\mu\text{s}$

3. Line period = (no. of active pixels + line overhead) \* pixel period

The number of active pixels per line is either 160 or 164. The interline pixel period overhead (including the 4 border pixels that can be enabled to qualify extra video information) is mode dependent, 43 pixel periods for 60fps or 135 pixel periods for 50fps. Refer to figure \* for more information.

Example: Line period =  $(160 + 43) \times 2.235\mu\text{s} = 453.705\mu\text{s}$

4. Frame period = (no. of active lines + frame overhead) \* line period

For the purposes of calculating the effective frame rate the number of active lines is assumed to be fixed at 120. The frame overhead (which includes the 4 border lines that can be enabled to qualify extra video information) has a constant value of 27 line periods. Refer to table \* for more information.

Example: Frame period =  $(120 + 27) \times 453.705\mu\text{s} = 66.694\text{ms}$

Frame rate =  $1 / \text{frame period} = 15 \text{ frames per second}$

### Digital Data Output Modes

VV5300 provides several different output modes. The different data formats are selected via the appropriate register in the serial interface, Setup0, [001\_0000<sub>2</sub>], bits 5 and 6. 8-bit or 4-bit pixel data conversion is also selected via the serial interface, Setup1, [001\_0001<sub>2</sub>]. If 4-bit pixel data conversion is selected as well as 8-Wire parallel output format then 2 consecutive pixel nibbles may be packed into a single output byte therefore increasing the effective frame rate.

Setup Bit 6	Setup Bit 5	Description	Comment
0	0	8-Wire Parallel	
0	1	4-Wire Parallel	default
1	0	Serial	
1	1	Serial UART	

**Data Output Modes**

### Frame Level Formatting

The frame level format for each mode is common and is given below. FST can be used for frame synchronisation. The FST pulse is exactly one line period in length and the rising edge occurs just before the status line start sequence (see line level formatting) is output.

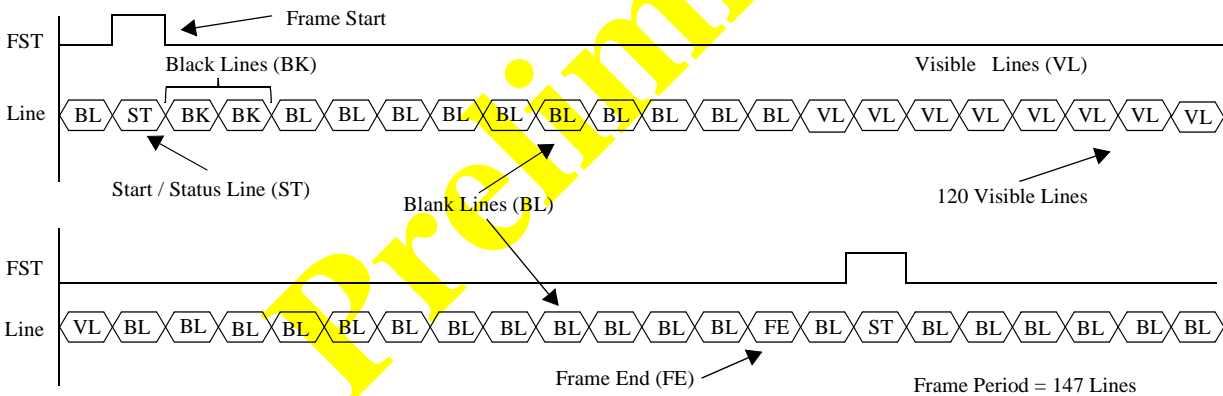

**Frame Format (160 x 120 mode)**

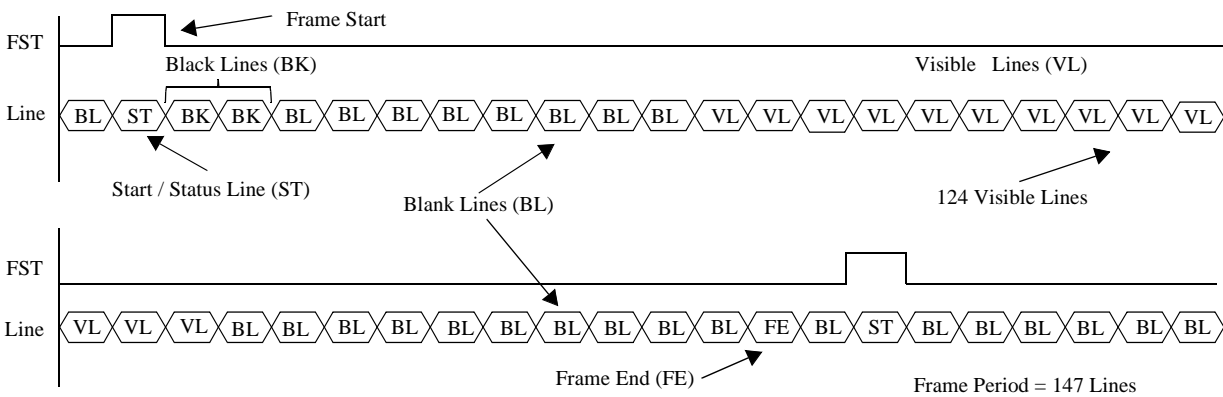

**Frame Format (164 x 124 mode)**

## Line Level Formatting

Each line type (black, blank, visible) has a specific format associated with it independent of the data output format selected. Each line begins with a start sequence of  $FF_H FF_H 00_H$  followed by  $XY_H$  where  $XY_H$  indicates the line type. The next two bytes provide supplementary data (specifically the line number within the current frame). Following this data are two guaranteed blank bytes ( $07_H 07_H$  for 8 bit modes,  $01_H 01_H$  for 4 bit modes). If the border lines/pixels have been enabled the next 2 bytes will be visible pixels otherwise they shall appear as blank bytes. The next part of the line is reserved for the 160 visible pixels. The 4 bytes following the visible pixels are formatted in the same way as the 4 bytes preceding the 160 visible pixels. At the end of each line, an end of line sequence is produced, ( $FF_H FF_H 00_H 80_H$ ). If the line is within the visible part of the frame, (lines 11 to 134 if the border lines are enabled otherwise lines 13 to 132), the end of line sequence is immediately followed by 2 bytes containing the mean values for the central 128 pixels. The first byte contains the mean value for the first 64 pixels of the middle 128 pixels and the second byte contains the mean value for the latter 64 pixels of the middle 128 pixels. The 128 pixels comprise the standard 120 visible pixels, the 4 border pixels and an extra 4 border pixels that are never enabled as visible pixels but are used for exposure control and hence contribute to the mean pixel value for the line. If the line type is not visible then the two bytes following the end of line sequence will contain  $07_H 07_H$ . For the remainder of the interline period the data output is always  $FF_H$ .

Sensor status and configuration information is output during the frame start line, (line 0), each data byte is separated by a blank value ( $07_H$ ) to avoid possible false line start conditions being generated. The information output during the status line reflects, if the sensor is operating in 8bit ADC mode, the first 64 locations in the serial interface register map. If the sensor is operating in 4 bit mode less data can be output during the status line. All the serial interface registers are 8bit values therefore 2, 4bit pixel periods are required to output a single serial interface location. Note that the serial interface data is only output during the visible monochrome pixels of the status line. This allows for one quarter of the serial interface address space to be output during any status line. It is possible to select the remaining registers in the serial interface for output, (see serial interface register setup 2, bits 7:6). The "end of frame" line, it is actually 2 lines prior to the status line will output the 4 exposure control bin averages during the first 4, (or 8 if operating in 4bit modes), monochrome pixels. Again the data is separated by mode dependent padding data.

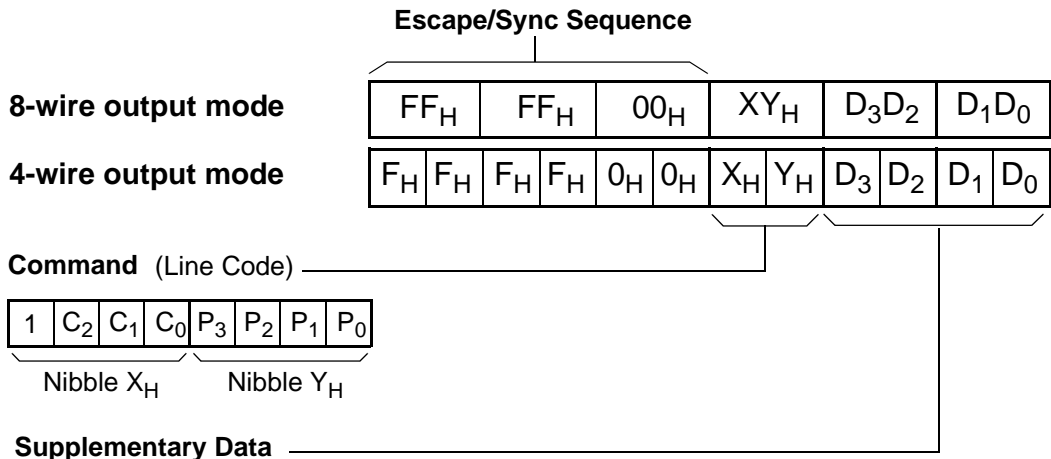

(i) Line Number (L<sub>11</sub> MSB)

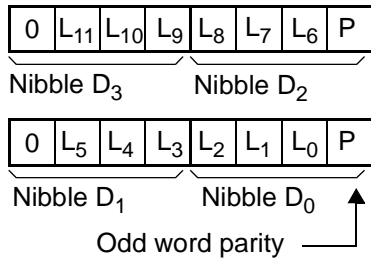

or (ii) If Line Code = End of Line then

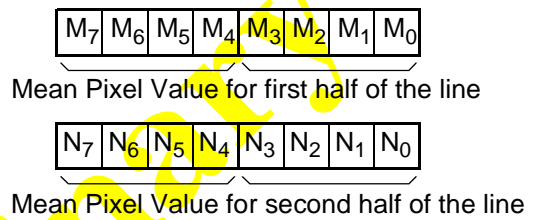

Line Code	Nibble X <sub>H</sub> [1 C <sub>2</sub> C <sub>1</sub> C <sub>0</sub> ]	Nibble Y <sub>H</sub> [P <sub>3</sub> P <sub>2</sub> P <sub>1</sub> P <sub>0</sub> ]
End of Line	1000 <sub>2</sub> (8 <sub>H</sub> )	0000 <sub>2</sub> (0 <sub>H</sub> )
Blank Line (BL)	1001 <sub>2</sub> (9 <sub>H</sub> )	1101 <sub>2</sub> (D <sub>H</sub> )
Black line (BK)	1010 <sub>2</sub> (A <sub>H</sub> )	1011 <sub>2</sub> (B <sub>H</sub> )
Visible Line (VL)	1011 <sub>2</sub> (B <sub>H</sub> )	0110 <sub>2</sub> (6 <sub>H</sub> )
Start of Frame (SOF)	1100 <sub>2</sub> (C <sub>H</sub> )	0111 <sub>2</sub> (7 <sub>H</sub> )
End of Frame (EOF)	1101 <sub>2</sub> (D <sub>H</sub> )	1010 <sub>2</sub> (A <sub>H</sub> )
Reserved	1110 <sub>2</sub> (E <sub>H</sub> )	1100 <sub>2</sub> (C <sub>H</sub> )
Reserved	1111 <sub>2</sub> (F <sub>H</sub> )	0001 <sub>2</sub> (1 <sub>H</sub> )

### Line Level Formatting





### 8-Wire Parallel Mode

8-Wire parallel mode is selected when the appropriate bits are set via the serial interface.

When 8-bit conversion mode is selected the 8-bit pixel data is output on pins DATA[7:0]. The start of a frame is indicated by a pulse on FST. The data is valid on the falling edge of the pixel sample clock fast QCK (QCK<sub>F</sub>) or on each edge of the slow QCK (QCK<sub>S</sub>).

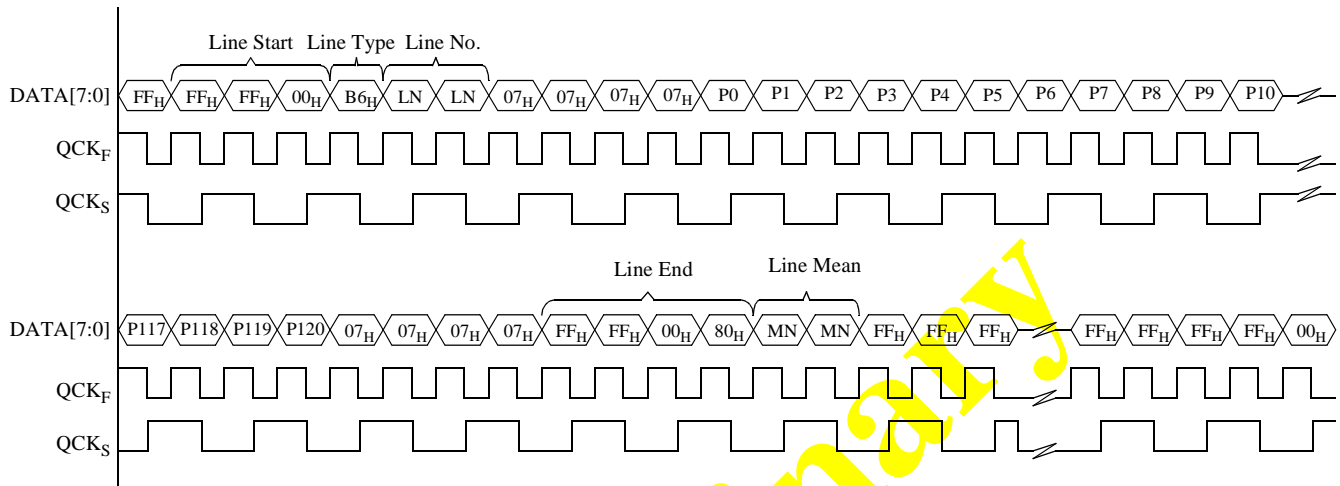

**8-Wire Parallel Mode (8-bit Pixel Data)**

When 4-bit conversion mode is selected the 4-bit pixel data is output two bytes at a time on the DATA[7:0] pins. The first pixel is mapped onto DATA[7:4] and the second pixel is output on DATA[3:0]. This effectively doubles the pixel rate (and halves the frame period).

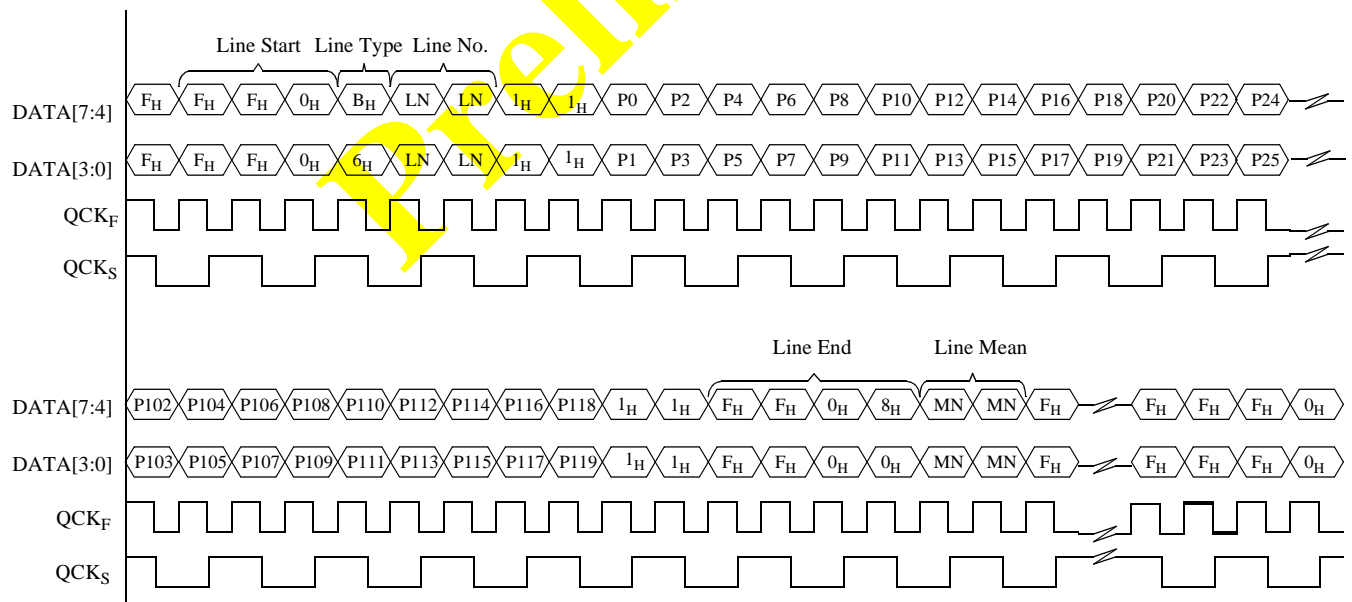

**8-Wire Parallel Mode (4-bit Pixel Data)**

### 4-Wire Parallel Mode

4-Wire parallel mode is selected when the appropriate bits are set via the serial interface. When 8-bit data conversion mode is selected (CONV8 = 1) the 8-bit pixel data is output on pins DATA[7:4] in two 4-bit nibbles. The start of a frame is indicated by a pulse on FST. A QCK sample edge is generated for each nibble.

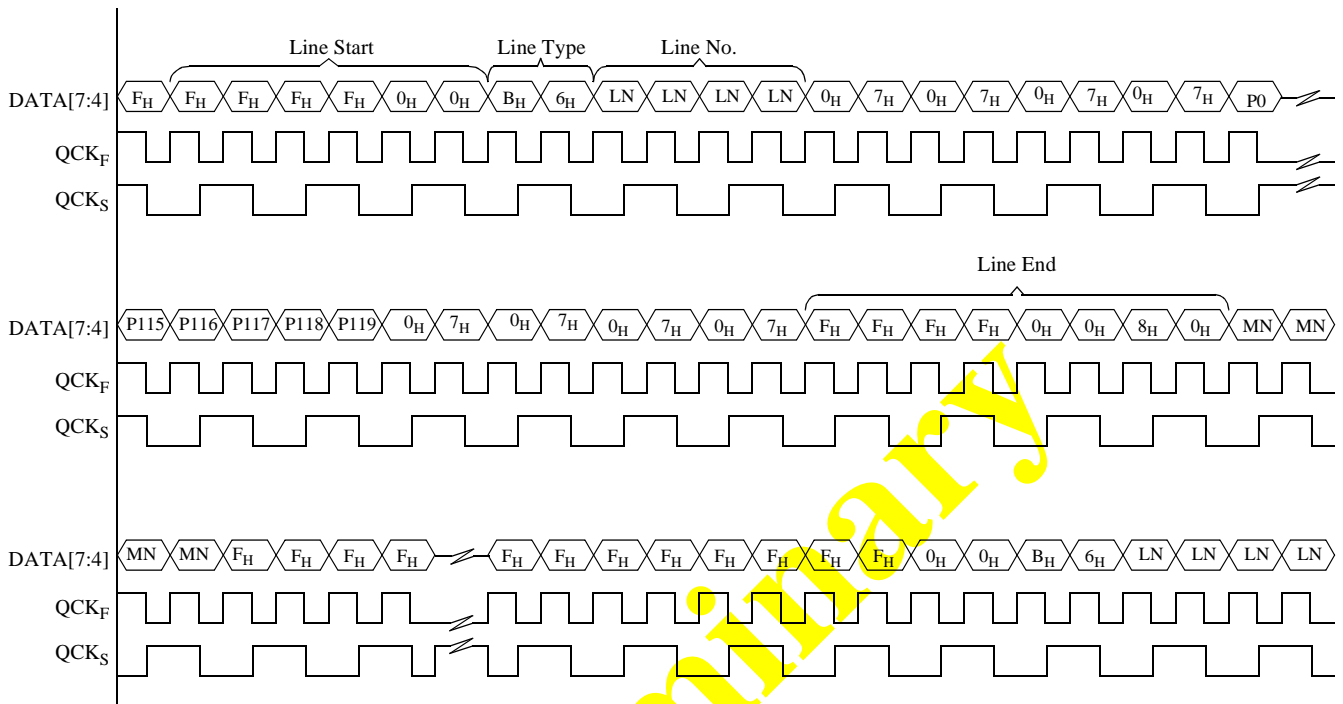

**4-Wire Parallel Mode (8-bit Pixel Data)**

When 4-bit data conversion mode is selected (CONV8 = 0) the 4-bit pixel data is output on pins DATA[7:4].

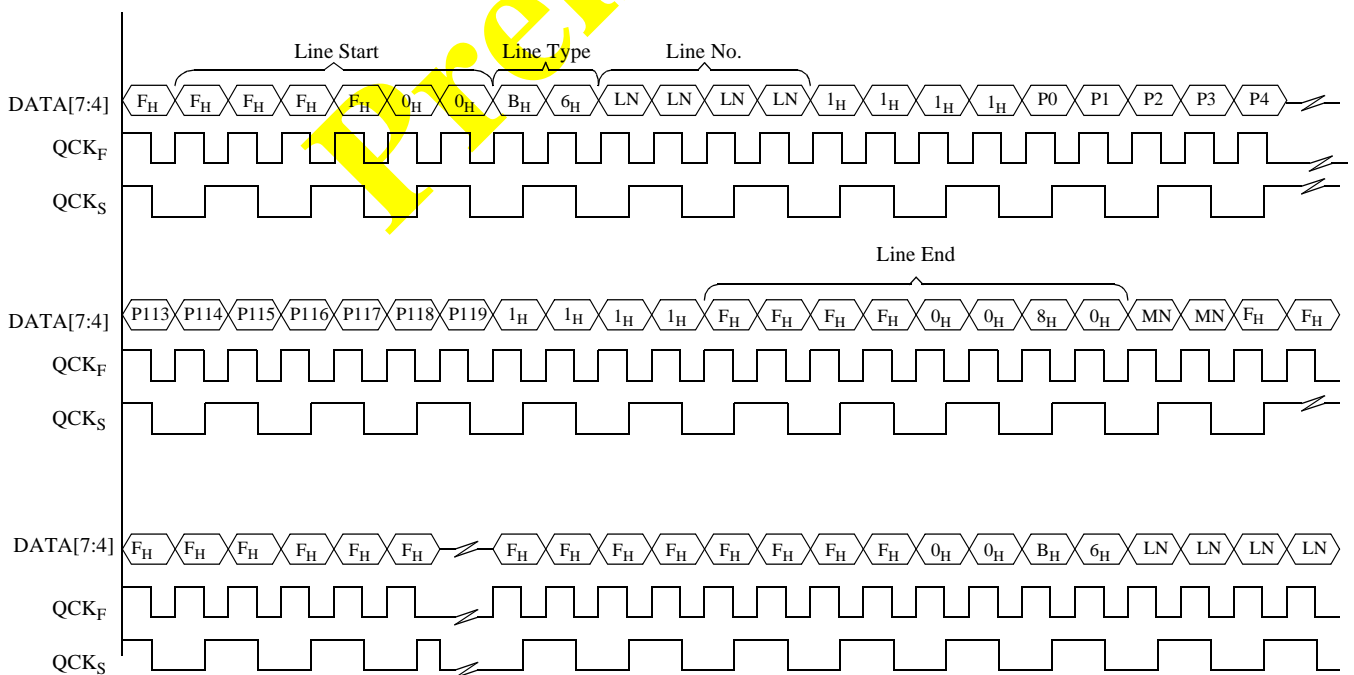

**4-Wire Parallel Mode (4-bit Pixel Data)**

### Serial Mode

Serial mode is selected when the appropriate bits are set via the serial interface. When 8-bit data conversion mode is selected the 8-bit pixel data is output on pin DATA[0] least significant bit first.

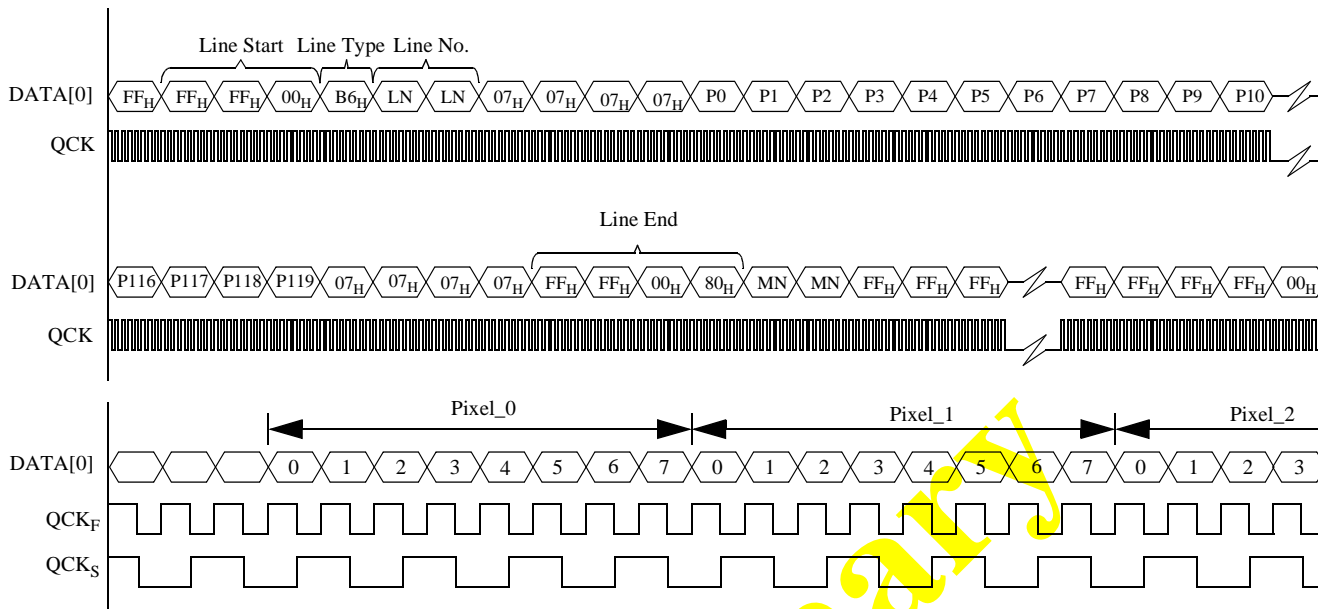

**Serial Mode (8-bit Pixel Data)**

When 4-bit data conversion mode is selected (CONV8 = 0) the 4-bit pixel data is output on pin DATA[0] least significant bit first.

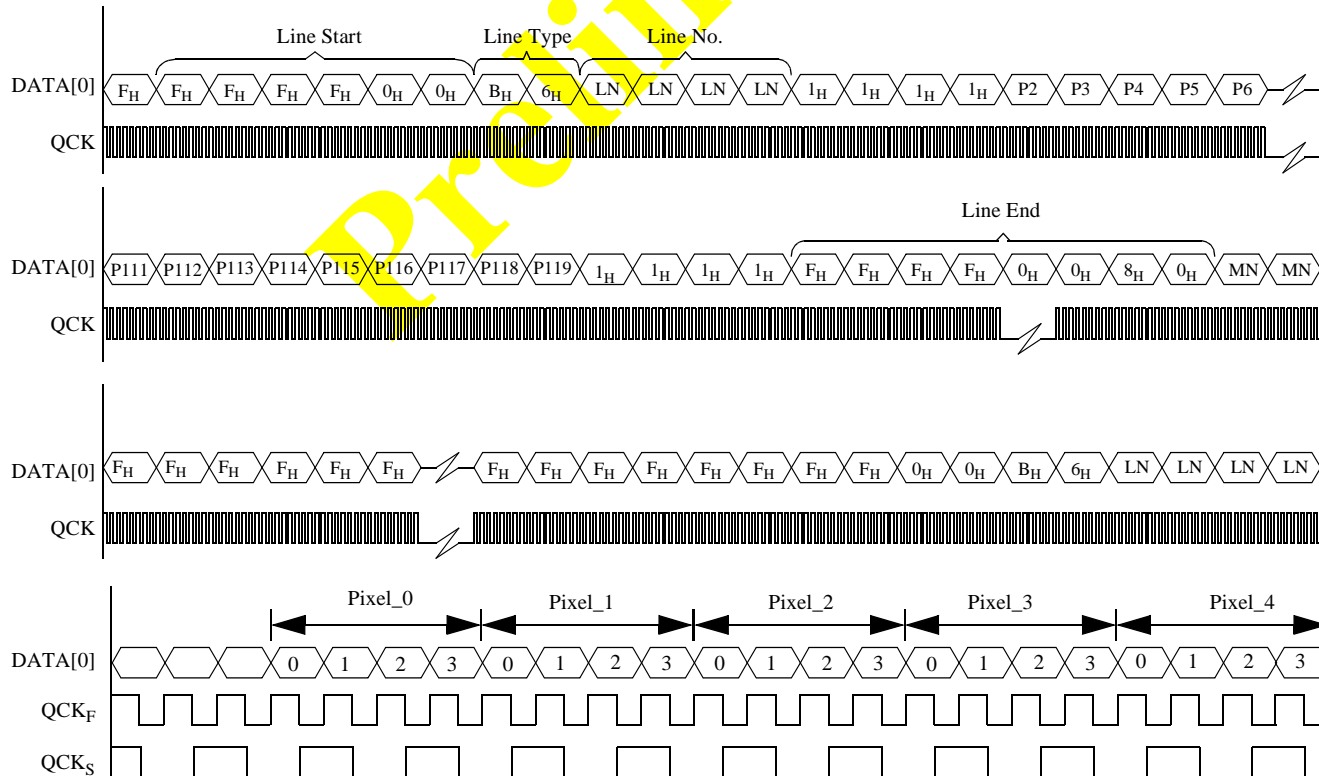

**Serial Mode (4-bit Pixel Data)**

### Serial UART Mode

Serial UART mode is selected when the appropriate bits are set via the serial interface. When 8-bit data conversion mode is selected the 8-bit pixel data is output on pin DATA[0] least significant bit first. Each pixel is preceded by a start bit and followed by an additional data bit and two stop bits.

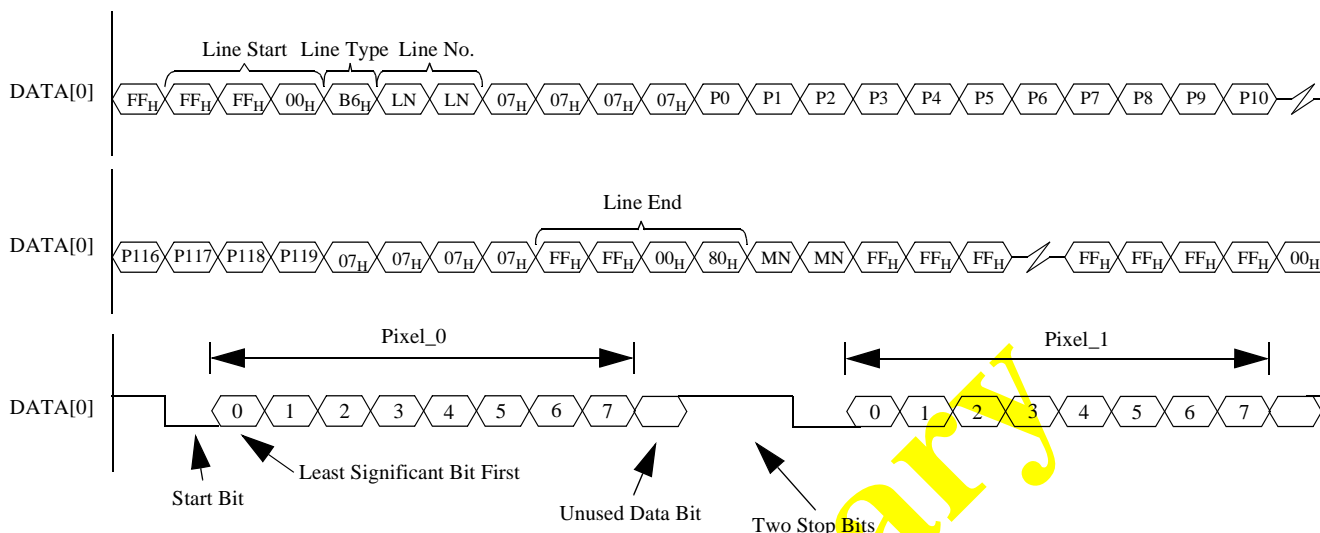

### Serial UART Mode (8-bit Pixel Data)

When 4-bit data conversion mode is selected the 4-bit pixel data is output two pixels at a time on pin DATA[0] least significant bit first. Each pixel is preceded by a start bit and followed by an additional data bit and two stop bits.

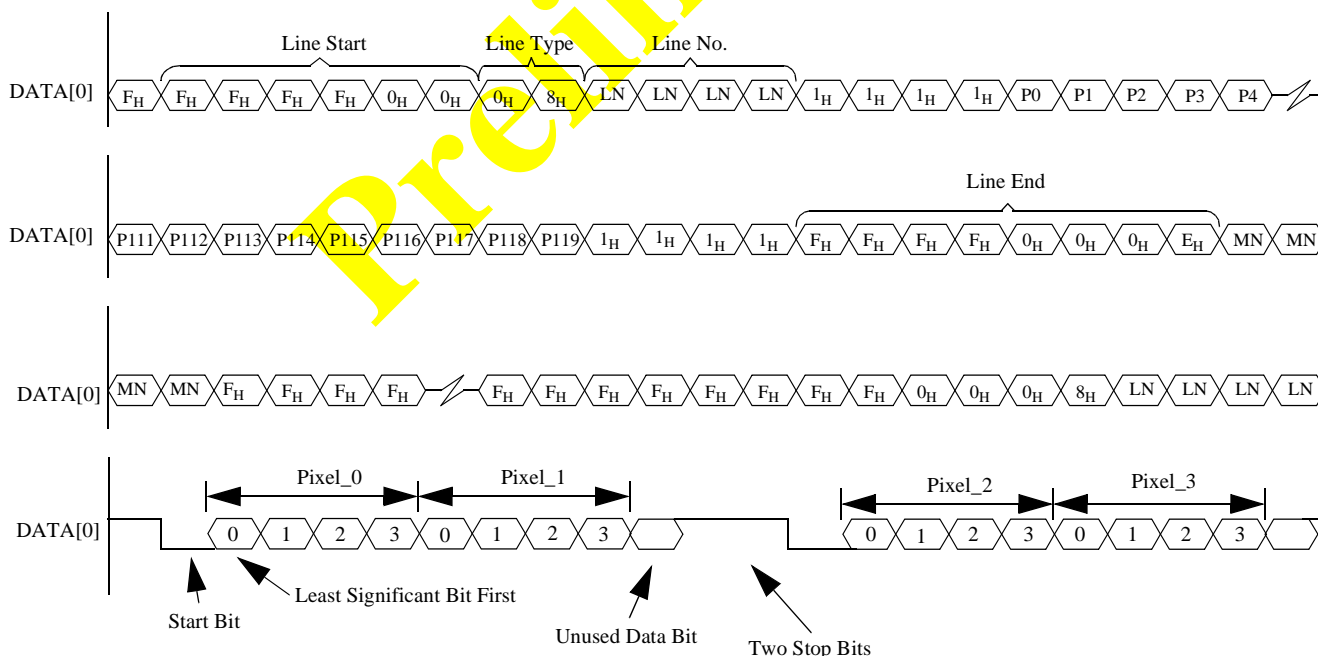

### Serial UART Mode (4-bit Pixel Data)

## Qualifying the Output Data

Data is output from VV5300 in a continuous stream. By utilising signals, like FST, and key events, like the start of a line or the end of line, the user can sample and display the image data. QCK is used to sample the data, as described in the previous section. By default the falling edge of QCK will sample the data, however it is possible to use both the rising and falling edges of a slow QCK QCK<sub>S</sub> to sample the data.

Different sections of the frame can be enabled by QCK. The options, which are selected via setup register4 in the serial interface, are as follows, firstly the QCK can be disabled, therefore no data will be qualified. This is the default option.

The second option is to have the QCK free running where all the data is qualified.

The third option is to only qualify the image data, which also includes the 2 black calibration monitor lines, lines 1 and 2 in the frame. This option is further complicated in that extra black lines and the extra border pixels/lines can be enabled giving the following 4 options:

1. Black lines (1-2) plus image (160 pixels by 120 lines)
2. Black lines (1-8) plus image (160 pixels by 120 lines)
3. Black lines (1-2) plus image (164 pixels by 124 lines)
4. Black lines (1-8) plus image (164 pixels by 124 lines)

The final option is to qualify the embedded frame control sequences as well as the image data. These control sequences are the 6 bytes at the start and at the end of each image line, where an image line is defined above. The frame start or status line, image and control sequence pixels, will also be qualified during this mode.

## QCK Exceptions

The output data from VV5300 can be formatted in many ways, as detailed in an earlier section of this document. Under certain operating conditions the relationship between QCK and the output data is compromised.

It is vital that the phase relationship between the output data stream and the QCK must be maintained from line to line, for example ensuring that, if enabled, the line code byte is always qualified by the same edge of the QCK, clearly only applicable when considering slow QCK qualification. It is known that there are an odd number of pixel periods in each line of the frame. If the slow QCK is selected then clearly two pixels are qualified during each QCK cycle resulting in the following modes of operation requiring special care: 4 bit ADC 8 wire output, 8 bit ADC 8 wire output and 4 bit ADC 4 wire output. During the interline period, when the data bus is outputting data fixed at FF (8bit ADC) or F (4bit ADC), the phase of the QCK is toggled, this will occur during every interline period. For the 8bit 8wire or 4bit 4 wire options this change is a simple inversion. The 4bit 8wire option is not quite as straightforward. During the interline period the QCK signal is changed from its former state to 1 of 3 other states. In addition 2 out of the 4 possible states are video timing mode dependent.

Please note that the number of nibbles/bytes qualified by the clocks described above, during the free running QCK mode, will differ from the expected value, as follows:

**QCK Exception Details**

Operating Mode	Number of pixels qualified 50 frames per second		Number of pixels qualified 60 frames per second	
	QCK <sub>F</sub>	QCK <sub>S</sub>	QCK <sub>F</sub>	QCK <sub>S</sub>
4bit 4wire	203	202	301	300
4bit 8wire	202	198	300	298
8bit 8wire	203	202	301	300

**Pixel qualification exceptions**

**Serial Interface - Exposure Control Handshake**

The process of writing timed exposure, clock division or gain settings to VV5300 using the serial interface requires special attention. These timed parameters can be written to the serial interface at any point within the frame timing but will only be transferred from shadow registers to their active registers at a specific point within the frame timing, see diagram below. Please note that writing immediate clock division or gain parameters are treated as a “normal” serial interface write messages.

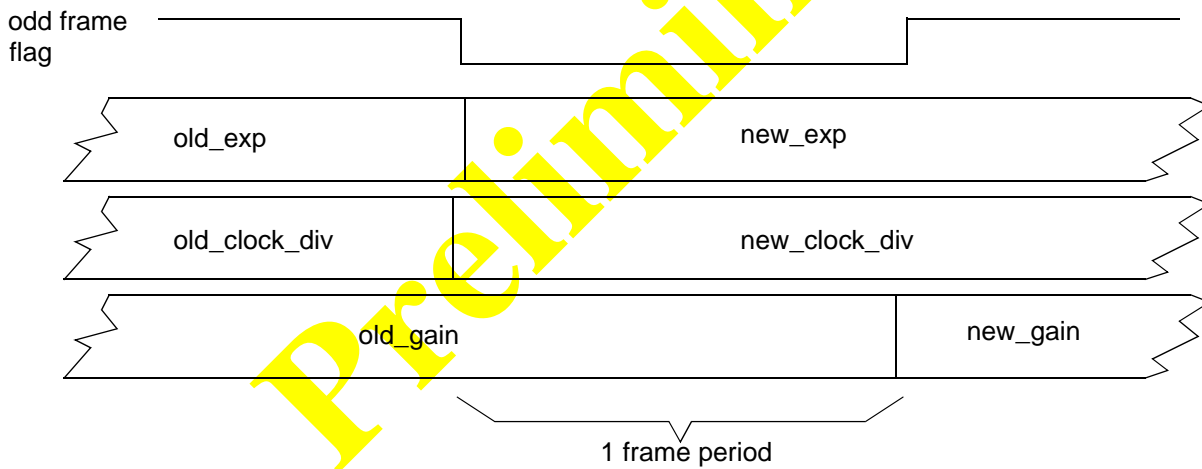

Since the new external exposure, clock division or gain settings are written to shadow registers the user continues to have full read/write access to the serial interface. A handshake system has been implemented between the exposure controller and the serial interface to avoid the user writing, for example, a second external timed gain value while the exposure controller has yet to transfer the first external timed gain value from the shadow register to the active register. If an external timed gain message has been written a special flag will be raised to indicate that it has yet to be transferred to the active register. This flag is available to the user via reading the status 0 register in the serial interface. Until the flag is lowered the user knows that it is not safe to write a further external gain value. Identical handshake protocols are used to implement timed external exposure and clock division writes.

## Auto Black Calibration

Black calibration is used to remove voltage offsets that cause shifts in the black level of the video signal. VV5300 is equipped with an automatic function that continually monitors the output black level and calibrates if it has moved out of range. Black calibration can be split into two stages, **monitor** (1 cycle) and **update** (3 cycles). During the monitor phase the current black level is compared against two threshold values. If the current value falls outside the threshold window then an update cycle is triggered. The update cycle can also be triggered by a change in the gain applied to sensor core or via the serial interface.

## Serial Interface

In order to be controlled and configured by its host, VV5300 can receive and transmit data via a two-wire serial interface.

### Serial Communication Protocol

The host must perform the role of a communications master and the camera acts as either a slave receiver or transmitter. The communication from host to camera takes the form of 8-bit data with a maximum serial clock frequency of up to 100kHz. Since the serial clock is generated by the host it determines the data transfer rate. The bus address for VV5300 is 20<sub>H</sub>. Data transfer protocol on the bus is shown below.

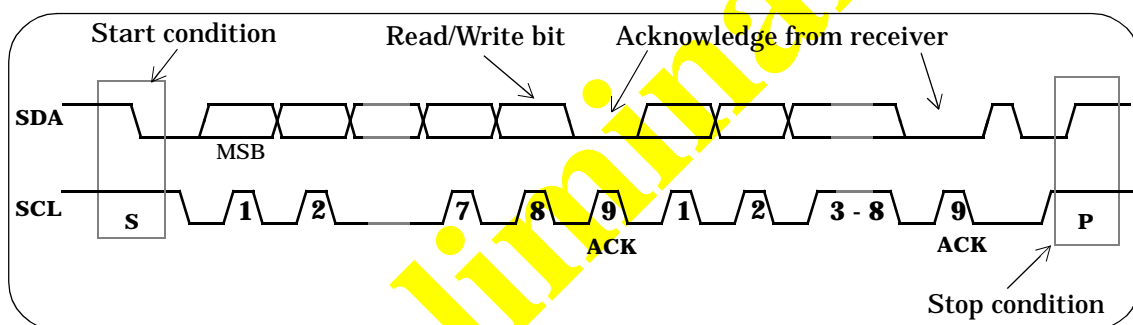

### Data Transfer Protocol

#### Data format

A message contains at least two bytes preceded by a *start* condition and followed by either a *stop* or *repeated start* followed by another message.

The first byte contains the device address byte which includes the data direction read/write bit. The device address is 32<sub>10</sub> Write, 33<sub>10</sub> Read. The 5 msbs of the address byte are fixed as 0010\_0<sub>2</sub>. The lsb of the address byte indicates the direction of the message. An even address causes the addressed slave to receive information from the master (write), an odd address indicates message read by the master.

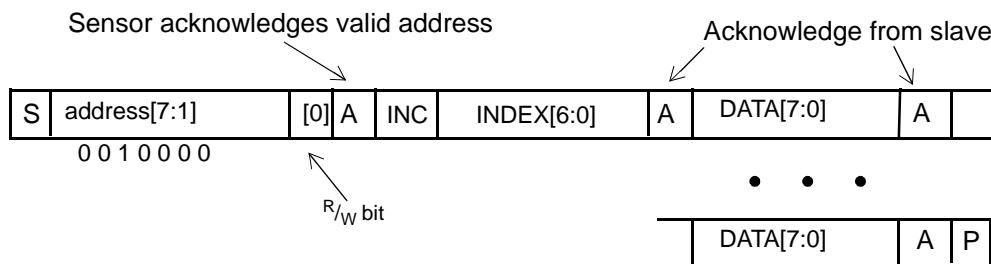

#### Data Format

After the read/write bit is sampled, the data direction cannot be changed, until the read/write bit next message is received. The next byte contains the location of the first data byte (also referred to as the *index*). There may be up to 128 such locations. If the msb of the second byte is set the automatic increment feature of the address index is selected.

## Message interpretation

All serial interface communications with the sensor must begin with a *start* condition. If the *start* condition is followed by a valid address byte then further communications can take place. The sensor will acknowledge the receipt of a valid address by driving SDA low. The state of the read/write bit (lsb of the address byte) is stored and the next byte of data can be interpreted.

During a write sequence the second byte received is an address index and is used to point to one of the internal registers. The msbit of the following byte is the *index auto increment* flag. If this flag is set then the serial interface will automatically increment the index address by one location after each slave acknowledge. The master can therefore send data bytes continuously to the slave until the slave fails to provide an acknowledge or the master terminates the write communication with a *stop* condition or sends a *repeated start*, (*Sr*). If the auto increment feature is used the master does *not* have to send indexes to accompany the data bytes.

As data is received by the slave it is written bit by bit to a serial/parallel register. After each data byte has been received by the slave, an acknowledge is generated, the data is then stored in the internal register addressed by the current index.

During a read message, the current index is read out in the byte following the device address byte. The next byte read from the slave device are the contents of the register addressed by the current index. The contents of this register are then parallel loaded into the serial/parallel register and clocked out of the device by *scl*. At the end of each byte, in both read and write message sequences, an acknowledge is issued by the receiving device. Although VV5300 is always considered to be a slave device, it acts as a transmitter when the bus master requests a read from the sensor.

At the end of a sequence of incremental reads or writes, the terminal index value in the register will be one *greater* the last location read from or written to. A subsequent read will use this index to begin retrieving data from the internal registers.

A message can only be terminated by the bus master, either by issuing a stop condition, a repeated start condition or by a negative acknowledge after reading a complete byte during a read operation.

## The programmers model

There are 128, 8-bit registers within the camera, accessible by the user via the serial interface. They are grouped according to function with each group occupying a 16-byte page of the location address space. There are eight such groups, The primary categories are given below:

- Setup registers with bit significant functions including status (read only) bits
- Exposure parameters that influence output image brightness.
- System functions and test bit significant registers.

Any internal register that can be written to can also be read from.



	Index	Name	R/W	Default	Comments
Status	000_0000		RO	1100 0000 <sub>2</sub> (C0 <sub>H</sub> )	Reserved
	000_0001		RO	0001 0010 <sub>2</sub> (12 <sub>H</sub> )	
	000_0010	status0	RO	0000 1000 <sub>2</sub> (08 <sub>H</sub> )	System status information
	000_0011	unused	-		
	000_0100	line_count	RO		Current line counter value
	000_0101	leftav	RO		Average value of pixels in the first half of the current line.
	000_0110	rghtav	RO		Average value of pixels in the second half of the current line.
	000_0111	frame_av	RO		Average value of pixels in a frame.
	000_1000	bin1	RO		Partial frame average - bin1
	000_1001	bin2	RO		Partial frame average - bin2
	000_1010	bin3	RO		Partial frame average - bin3
	000_1011	bin4	RO		Partial frame average - bin4
	000_11xx	unused	-		
Setup	001_0000	setup0	R/W	0010_0111 <sub>2</sub> (27 <sub>H</sub> )	Configure the digital logic
	001_0001	setup1	R/W	0111_0000 <sub>2</sub> (70 <sub>H</sub> )	Configure the digital logic
	001_0010	setup2	R/W	0001_1111 <sub>2</sub> (1F <sub>H</sub> )	Pixel counter reset value
	001_0011	setup3	R/W	0000_1111 <sub>2</sub> (0F <sub>H</sub> )	Exposure control modes
	001_0100	setup4	R/W	0000_0000 <sub>2</sub> (00 <sub>H</sub> )	FST/QCK options
	001_0101	unused	-		
	001_011x	unused	-		
	001_1xxx	unused	-		
Exposure	010_0000	unused	-		
	010_0001	fine	R/W	0000_0000 <sub>2</sub> (00 <sub>H</sub> )	Fine exposure initially zero
	010_0010	unused	-		
	010_0011	coarse	R/W	0111_0000 <sub>2</sub> (70 <sub>H</sub> )	Coarse exposure
	010_0100	gain	R/W	0000_0000 <sub>2</sub> (00 <sub>H</sub> )	Gain value
	010_0101	clk_div	R/W	0000_0000 <sub>2</sub> (00 <sub>H</sub> )	Clock division
	010_0110	gn_lim	R/W	0000_0111 <sub>2</sub> (07 <sub>H</sub> )	Maximum allowable gain
	010_0111	tl	R/W	0101_0101 <sub>2</sub> (55 <sub>H</sub> )	Lower exposure control threshold.
	010_1000	tc	R/W	1001_0110 <sub>2</sub> (64 <sub>H</sub> )	Centre exposure control threshold.
	010_1001	th	R/W	0110_0110 <sub>2</sub> (73 <sub>H</sub> )	Upper exposure control threshold.
	010_101x	unused	-		
	010_1xxx	unused	-		
System	111_0011	xfav	R/W	1000_0000 <sub>2</sub> (80 <sub>H</sub> )	External frame average
	111_0101	dcth	R/W	1000_0000 <sub>2</sub> (80 <sub>H</sub> )	Digital comparator threshold
	111_1001	unused			
	111_1010	unused			
	111_1011	unused			
	111_11xx	unused			

### The programmers model

A detailed description of each register follows. The address indexes are shown as binary in brackets.

**Status 0 [000\_0010<sub>2</sub>]**

The loading of certain system parameters is timed to avoid disturbing the video signal part way through a frame. Bits 0-2 can be polled to check that a value written to either the exposure, gain or clock division registers has been consumed or not. Bit 3 is essentially an internal flag differentiating between consecutive frames.

Bit	Function	Default	Comment
0	Exposure value update pending	0	New exposure setting sent but not yet consumed by the exposure controller
1	Clock division value update pending	0	New clock division setting sent but not yet consumed by the exposure controller
2	Gain value update pending	0	New gain value sent but not yet consumed by the exposure controller
3	Odd/even frame	0	The flag will toggle state on alternate frames
4	Black Calibration fail flag	0	If the black calibration algorithm returns very poor black levels - outwith both the calibration and monitor windows then this flag will be set and it will stay set until the next successful calibration is complete
7:5	Unused	0	

**Status 0 [000\_0010<sub>2</sub>]**

**Line\_count [000\_0100<sub>2</sub>]**

Bits	Function	Default	Comment
7:0	Line count	0000_0000 <sub>2</sub>	Displays current line count

**Line\_count [000\_0100<sub>2</sub>]**

The video timing logic is controlled by the pixel counter and the line counter. To reduce the level of digital switching noise these counters implement a gray count sequence, where only a single counter register can change state in a clock period. However the gray count sequence is user unfriendly, e.g. 248,232,233, 235,234. A binary version of the line count is generated internally, realising a 0,1,2,3,4..... sequence, and it is this count sequence that is read by the serial interface and hence made available to the sensor user.

**Line\_avg 0 [000\_0101<sub>2</sub>] & Line\_avg 1 [000\_0110<sub>2</sub>]**

The exposure controller accumulates the pixel output values. On a line by line basis the accumulation is performed in two stages. The qualified pixels in the left half of the video line are accumulated and then stored in a latch. The process is then repeated during the right half of the video line. During the interline line period (up until the latch that stores the value for the left half of the line is updated during the next line) the latches will present valid average 8-bit pixel values for both halves of the line.

Bits	Function	Default	Comment
7:0	Line average	0	Average pixel value for first half of current line.

**Line\_avg 0 [000\_0101<sub>2</sub>]**

Bits	Function	Default	Comment
7:0	Line average	0	Average pixel value for second half of current line.

**Line\_avg 1 [000\_0110<sub>2</sub>]**

**Frame\_avg [000\_0111<sub>2</sub>]**

The average pixel values stored in latches halfway through and at the end of each active video line are ultimately stored in bins that will maintain a frame sum of the pixel values. At the end of the frame the values stored in these bins are used to determine the overall pixel average for the whole frame.

Bits	Function	Default	Comment
7:0	Frame average	0	Pixel average for previous frame

**Frame\_avg [000\_0111<sub>2</sub>]****Bin1\_avg [000\_1000<sub>2</sub>]**

Bits	Function	Default	Comment
7:0	Bin1 average	0	Pixel average for current line

**Bin1\_avg [000\_1000<sub>2</sub>]****Bin2\_avg [000\_1001<sub>2</sub>]**

Bits	Function	Default	Comment
7:0	Bin2 average	0	Pixel average for current line

**Bin2\_avg [000\_1001<sub>2</sub>]****Bin3\_avg [000\_1010<sub>2</sub>]**

Bits	Function	Default	Comment
7:0	Bin3 average	0	Pixel average for current line

**Bin3\_avg [000\_1010<sub>2</sub>]****Bin4\_avg [000\_1011<sub>2</sub>]**

Bits	Function	Default	Comment
7:0	Bin4 average	0	Pixel average for current line

**Bin4\_avg [000\_1011<sub>2</sub>]**

### Setup 0 [001\_0000<sub>2</sub>]

Setup registers 0,1,2,3 and 4 are used to alter the operating parameters of the sensor. All of these registers can be written to and read from.

Setup 0 register controls some fundamental exposure and output format parameters. Defaults are shown in **Bold**.

Bit	Function	Default	Comment
0	Automatic exposure control. <b>Off/On</b>	1	Enables or disables automatic exposure control. Current exposure value is frozen when disabled.
1	Clamp fine exposure <b>Off/On</b>	1	If this bit is set <i>and</i> aec is enabled <i>and</i> the coarse exposure has exceeded the clamp threshold, 16, then the fine exposure will be clamped to 0.
2	Automatic gain control. <b>Off/On</b>	1	Enables or disables automatic gain control. Current gain value is frozen when disabled.
3	Enable immediate gain update. <b>Off/On</b>	0	Allow manual change to gain to be applied immediately.
4	Enable immediate clock division update. <b>Off/On</b>	0	Allow manual change to clock division to be applied immediately.
6:5	Data format select.	01	<b>00</b> - 8 wire parallel output <b>01</b> - 4 wire parallel output 10 - 2 wire serial output 11 - 1 wire serial output
7	3/4 crystal clock <b>Off/On</b>	0	Achieves clock division by 3 rather than 4.

### Setup0 [001\_0000<sub>2</sub>]

### Setup 1 [001\_0001<sub>2</sub>]

Setup 1 register controls registers that are less likely to be modified on a regular basis. The user should note that the border pixels/lines can be disabled/enabled independently from the enabling/disabling of the custom analogue horizontal shift register.

Bit	Function	Default	Comment
0	Enable additional black lines (3-8) <b>Off/On</b>	0	If enabled extra black lines are visible at device output
1	Enable border pixels <b>Off/On</b>	0	Extends qualified image size to 164 x 124. Default image size is 160 x 120
2	Enable horizontal shuffle mode. <b>Off/On</b>	0	The contents of the horizontal shift register are shuffled so that all the even columns then all the odd columns are read out.

### Setup1 [001\_0001<sub>2</sub>]

Bit	Function	Default	Comment
3	Enable sample mode <b>Off/On</b>	0	If enabled the data bus will continuously output a "96 <sub>H</sub> " pattern. With the sensor in this mode a user can determine the best point at which to sample the data.
4	Status line data output enable. <b>Off/On</b>	1	Enables the output of serial interface status information on the data bus. By default the bottom 64 locations from the serial interface will be output.
5	<b>8-bit</b> or 4-bit ADC select	1	The analogue output ADC can be configured to convert to 4-bit or 8-bit resolution.
6	50fps timing/ <b>60fps timing</b>	1	The sensor will implement 60Hz like line timing by default giving reduced flicker operation with 60Hz source frequencies. If the supply frequency is 50Hz then 50Hz like timing should be selected.
7	External frame average <b>Off/On</b>	0	Normally the accumulator arithmetic logic calculates the frame average of the pixel samples. However if this bit is enabled then the user may specify a frame average.

**Setup1 [001\_0001<sub>2</sub>]**

**Setup 2 [001\_0010<sub>2</sub>]**

In many systems VV5300 will be continuously synchronised. During this synchronisation the video timing is reset to a fixed point within the frame timing. The counter reset value is definable.

Bit	Function	Default	Comment
5:0	Pixel counter reset value.	011111 <sub>2</sub>	During synchronisation the pixel counter is reset to the defined value.
6	Status information output option. <b>Off/On</b>	0	Selects which system parameters are output on status line. See table below.
7	Status information output option. <b>Off/On</b>	0	Selects which system parameters are output on status line. See table below.

**Setup 2 [001\_0010<sub>2</sub>]**

Bit 7	Bit 6	Register Address Range 8-bit modes	Register Address Range 4-bit modes
0	0	00 <sub>H</sub> - 3F <sub>H</sub>	00 <sub>H</sub> - 1F <sub>H</sub>
0	1	40 <sub>H</sub> - 7F <sub>H</sub>	20 <sub>H</sub> - 3F <sub>H</sub>
1	0	-	40 <sub>H</sub> - 5F <sub>H</sub>

**Status line information options**

Bit 7	Bit 6	Register Address Range 8-bit modes	Register Address Range 4-bit modes
1	1	-	60 <sub>H</sub> - 7F <sub>H</sub>

**Status line information options**

**Setup 3 [001\_0011<sub>2</sub>]**

Bit	Function	Default	Comment
3:0	Exposure control mode select.	1111 <sub>2</sub>	The average value for the frame that the exposure controller uses can be calculated in a number of different ways. See table below.
4	Autoload control	0	This bit controls the autoload feature. <i>Note1</i>
6:5	Exposure step size	01	Selects exposure step size. 1/8 for fast but jerky convergence to 1/64 for slow but smooth convergence. Default 1/16.
7	Unused	0	

**Setup 3 [001\_0011<sub>2</sub>]**

Note1: The state of this pin can affect the autoload function in a number of ways.

1. If the autoload bit is high continuously and the autoload pin is also high then an autoload will not take place.
2. If the autoload bit is initially high and is then forced low then an autoload will take place regardless of the state of the autoload pin.
3. If the autoload pin is initially high and is then forced low an autoload will take place regardless of the state of the autoload bit.
4. A low to high transition on either the autoload bit or the autoload pin while VV5300 is running will have no effect on the autoload function.

Bit 3	Bit 2	Bit 1	Bit 0	Function
0	0	0	0	bin1
0	0	0	1	bin2
0	0	1	0	bin3
0	0	1	1	bin4
0	1	0	0	(bin1 + bin2) / 2
0	1	0	1	(bin3 + bin4) / 2
0	1	1	0	(bin1 + bin3) / 2
0	1	1	1	(bin2 + bin4) / 2
1	0	0	0	(bin1 + bin4) / 2
1	0	0	1	(bin2 + bin3) / 2

**Frame Average Options**

Bit 3	Bit 2	Bit 1	Bit 0	Function
1	0	1	0	$(bin1 + bin2 + bin3 + bin4) / 4$
1	0	1	1	$(bin1 + bin2 + bin3 + bin4) / 4$

**Frame Average Options**

Bit 6	Bit 5	Step size	Comment
0	0	1/8	
0	1	1/16	Default
1	0	1/32	
1	1	1/64	

**Exposure step size options**

**Setup 4 [001\_0100<sub>2</sub>]**

The data output on the serial wire or the 4 wire/8 wire busses can be qualified, if required, by an internally generated clock signal, QCK. This clock can be configured variously. Both a *fast* and a *slow* QCK can be generated. If the former is selected then the falling edge of the clock will qualify the current data nibble/byte, i.e. if the sensor is operating in 4 bit-4 wire mode then any true 8 bit data (e.g. line type code) will be qualified on a nibble basis. If the *slow* QCK option is preferred then both edges of this clock are used to qualify the current data nibble/byte.

The QCK function has a dedicated pin assigned, however by selecting the appropriate bits the FST pin can also output QCK data. By default QCK is disabled. However by writing the appropriate message, QCK can be forced to free run, qualify the embedded coding sequences and the visible data or the visible data only. FST can also be enabled or disabled or alternatively the FST pin can output a timing signal to synchronise several VV5300 sensors or finally the FST pin can output the state of the custom analogue block successive approximation ADC output comparator.

Bit	Function	Default	Mode		
1:0	FST/QCK pin mode.	00 <sub>2</sub>		FST pin	QCK pin
			00 <sub>2</sub>	Normal FST	QCK <sub>S</sub>
			01 <sub>2</sub>	Normal FST	QCK <sub>F</sub>
			10 <sub>2</sub>	QCK <sub>F</sub>	QCK <sub>S</sub>
			11 <sub>2</sub>	Inverted QCK <sub>F</sub>	QCK <sub>F</sub>
3:2	QCK mode select	00 <sub>2</sub>	00 <sub>2</sub>	disable	
			01 <sub>2</sub>	free running	
			10 <sub>2</sub>	validate control and image data	
			11 <sub>2</sub>	validate image data only	
5:4	unused	00 <sub>2</sub>			
7:6	FST mode select	00 <sub>2</sub>	00 <sub>2</sub>	disable FST	
			01 <sub>2</sub>	enable FST	
			10 <sub>2</sub>	synchronisation pulse output (SNO)	
			11 <sub>2</sub>	output ADC comparator output, CPO	

**Setup 4 [001\_0100<sub>2</sub>]**

## Exposure Control Registers [010\_0001<sub>2</sub>] - [010\_1001<sub>2</sub>]

There is a set of parameters that control the time that the sensor pixels are exposed. The parameters are as follows: fine and coarse exposure time, clock division control and finally gain control. The latter parameter does not affect the integration period rather it amplifies the video signal at the output stage of the sensor core. An internal automatic algorithm will, if enabled, continually monitor the pixel output and then, if required, use this data to correct the current exposure.

Manually changing the divisor applied to the incoming crystal clock can alter the effective integration of the sensor. By slowing the internal clock down the integration period can be increased, i.e. halving the pixel clock frequency will double the integration period.

If the user wishes to use the automatic exposure algorithm, the automatic exposure control (controlling *fine* and *coarse* exposure) must be enabled. Additional gain control is optional. It is also possible to change the gain manually via the serial interface even if the exposure is adjusted automatically.

If a user wishes to write an external value to one of the automatic exposure algorithm registers then it is advised that the automatic control for that register be disabled prior to using the serial interface to write the external value.

*Note:* The external exposure (coarse, fine or gain) values do not take effect immediately. Data from the serial interface is read by the exposure algorithm at the start of a video frame. If the user reads an exposure value via the serial interface then the value reported will be the data as yet unconsumed by the exposure algorithm, because the serial interface logic locally stores all the data written to the sensor.

Between writing the exposure data and the point at which the data is consumed by the exposure algorithm, bit 0 of the status register is set. The gain value is updated a frame later than the coarse and fine exposure parameters. The gain is applied directly at the video output stage and does not require the long set up time of the coarse and fine exposure settings.

The automatic exposure algorithm uses a set of exposure threshold settings. These thresholds may also be modified by the user to alter the algorithm's performance. The exposure algorithm uses these thresholds in a histogram. The three thresholds divide the histogram into 4 regions, very overexposed, overexposed, underexposed and very underexposed. The pixel data received from the sensor core is compared against the thresholds to determine the accuracy of the current exposure setting. A series of flags are set to describe the outcome of the histogram comparison and the new exposure setting can then be derived.

Each exposure parameter is subject to a maximum setting. The fine exposure setting can be clamped to a fixed value regardless of the decision made by the automatic algorithm. The clamping will occur if the coarse exposure setting exceeds a predetermined value and the clamping has been enabled via the serial interface.

Bit	Function	Default	Comment
7:0	Fine exposure value	0000_0000 <sub>2</sub> (00 <sub>H</sub> )	maximum fine (50Hz mode) = FF <sub>H</sub> maximum fine (60Hz mode) = A8 <sub>H</sub>

### Fine Exposure Value [010\_0001<sub>2</sub>]

Bit	Function	Default	Comment
7:0	Coarse exposure value	0111_0000 <sub>2</sub> (70 <sub>H</sub> )	maximum coarse (50Hz and 60Hz modes) 91 <sub>H</sub>

### Coarse Exposure Value [010\_0011<sub>2</sub>]



Bit	Function	Default	Comment
2:0	Gain value	0	8 possible gain states can be written via the serial interface

**Gain Value [010\_0100<sub>2</sub>]**

All 8 binary codes can be written to the core via the serial interface. Only the 4 thermometer codes 000,001,011 and 111 are selected by the automatic exposure algorithm. The 4 other codes are however still valid and will be evaluated as detailed in the table below. It is clear, from the non-linear relationship between the binary code and the actual gain applied at the analogue output stage, that care should be taken when using non thermometer code gain settings. If the user writes a gain code of 110 (real gain = 1.600) and then enables automatic gain control and the controller then decided to reduce the gain, the new gain value would be 011 (real gain = 4.000) i.e. the effective applied gain at the analogue output stage has actually been increased.

Gain binary code	Actual signal gain
000	1.000
001	2.000
010	1.333
011	4.000
100	1.143
101	2.667
110	1.600
111	8.000

**System Gain**

Bit	Function	Default	Comment
1:0	Clock divisor value	0	Pixel clock = Crystal clock ÷ 2 <sup>n+1</sup>

**Clock Divisor Value [010\_0101<sub>2</sub>]**

The *undivided* input crystal clock is used by the clock generator circuitry, elements of the serial interface and a small number of other registers in the design. The remaining digital logic and the analogue circuitry, use internally generated clocks, namely the pixel clock and the faster ADC clocks. These clocks are all slower versions of the crystal clock. The ADC clocks may be up to half the crystal frequency, but can be further divided by factors of 2, 4 or 8. The pixel clock is in turn slower than the ADC clock. If the ADC is operating in 4 bit mode then the pixel clock is 1/4 the frequency of the ADC clock, otherwise the pixel clock will be 1/8 the frequency of the ADC clock.

Bit	Function	Default	Comment
2:0	Gain limit	7	

**Gain Limit[010\_0110<sub>2</sub>]**

Bit	Function	Default	Comment
7:0	Exposure lower threshold	85	

**Exposure Lower Threshold [010\_0111<sub>2</sub>]**

Bit	Function	Default	Comment
7:0	Exposure centre threshold	100	

**Exposure Centre Threshold [010\_1000<sub>2</sub>]**

Bit	Function	Default	Comment
7:0	Exposure higher threshold	115	

**Exposure Higher Threshold [010\_1001<sub>2</sub>]**

**Frame Average [111\_0011<sub>2</sub>]**

The exposure controller normally compiles a frame average from the data received from the core. A complete frame period is required to produce a frame average. This is clearly unacceptable for simulation and test purposes. It is possible to manually force a frame average via the serial interface. This feature together with the ability to curtail the frame duration will allow the behaviour of the exposure controller to be examined in a realistic simulation period.

This register is read/write compatible

Bit	Function	Default	Comment
7:0	Frame average	0	Allow a synthetic frame average to be written to and used by the exposure controller

**Frame Average [111\_0011<sub>2</sub>]**

**Digital Comparator Threshold [111\_0101<sub>2</sub>]**

The ADC output from the CAB can be digitally compared against a digital threshold. This threshold is fully programmable via the serial interface register. If the current ADC output is greater than or equal to the programmed threshold then the modified ADC output will be forced to the full scale output. The full scale value is mode dependent:- 224 for 8 bit ADC conversion or 14 for 4 bit conversion. If the current ADC output is less than the threshold then the modified ADC output will be forced to minimum video. The minimum video setting (the black level) is again mode dependent:- 16 for 8 bit ADC conversion or 1 for 4 bit conversion.

If this feature is not enabled, (tms[7] = 0), then the ADC output will pass unaltered.

As indicated above the ADC can convert to either 4 bit or 8 bit accuracy. When operating in a 4-bit mode the threshold value should be packed to the 4 most significant bits of the register i.e. if the required threshold

value is 10 then 160 should be written to the threshold register.

Bit	Function	Default	Comment
[7:0]	Threshold for digital comparator	128	The default has been set at the mid-range video setting for 8 bit ADC conversion. The user must reprogram the register if the test is run when the ADC is converting to 4 bit accuracy.

**Digital Comparator Threshold [111\_0101<sub>2</sub>]**

**Preliminary**

## Types of messages

This section gives guidelines on the basic operations to read data from and write data to the serial interface.

The serial interface supports variable length messages. A message may contain no data bytes, one data byte or many data bytes. This data can be written to or read from common or different locations within the sensor. The range of instructions available are detailed below.

- No data byte, only sets the index for a subsequent read message.
- Single location multiple data write or read for monitoring for real time control
- Multiple location, multiple data read or write for fast information transfers.

Examples of these operations are given below. A full description of the internal registers is given in the previous section

For all examples the slave address used is  $0010000_2=32_{10}$  for writing and  $0010001_2=33_{10}$  for reading. This corresponds to applying logical zero to both the *sab0* and *sab1* inputs.

### Single location, single data write.

When a random value is written to the sensor, the message will look like this:

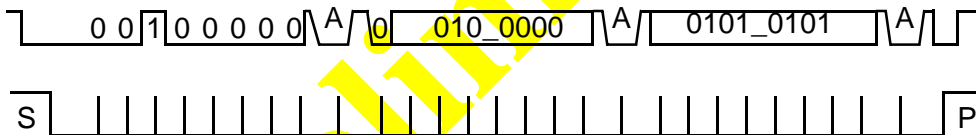

In this example, the *coarse* (index =  $0100000_2=32_{10}$ ) exposure value has been written as  $01010101_2$ . The *r/w* bit is set to zero for writing and the *inc* bit is set to zero to disable automatic increment of the index after writing the value. The location is preserved and may be used by a subsequent read.

### Single location, single data read.

A read message always contains the index used to get the first byte.

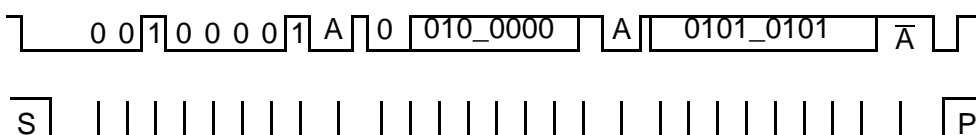

This example shows a *coarse* (index =  $32_{10}$ ) value of  $0101_0101_2$  been read. Note that the read message is terminated with a negative acknowledge ( $\bar{A}$ ) from the master: it is not guaranteed that the master will be able to issue a stop condition at any other time during a read message. This is because if the data sent by the slave is all zeros, the *sda* line cannot rise, which is part of the stop condition.

**No data write followed by same location read.**

When a location is to be read, but the value of the stored index is not known, a write message with no data byte must be written first, specifying the index. The read message then completes the message sequence. To avoid relinquishing the serial to bus to another master a repeated start condition is asserted between the write and read messages. In this example, the *gain* value (index =  $36_{10}$ ) is read as  $15_{10}$ :

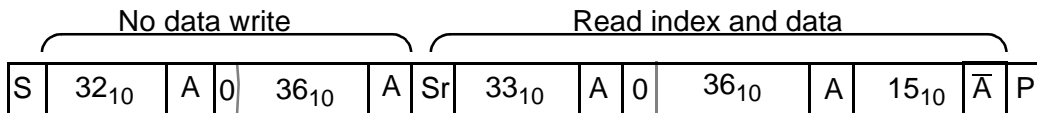

As mentioned in the previous example, the read message is terminated with a negative acknowledge ( $\bar{A}$ ) from the master.

**Same location multiple data write.**

It may be desirable to write a succession of data to a common location. This is useful when the status of a bit, (e.g. requesting a new black calibration), must be toggled.

The message sequence indexes *setup1* register and initially turns *ABC* off. The next two data bytes then turn *ABC* on and then finally off again, leaving it in the default state.

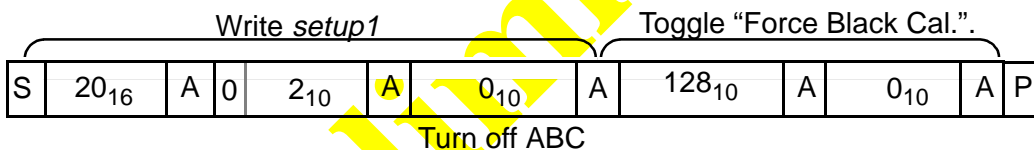

**Same location multiple data read**

When an exposure related value (*coarse*, *fine*, *acc* or *gain*) is written, it takes effect on the output at the beginning of the next video frame, (remember that the application of the *gain* value is a frame later than the other exposure parameters). To signal the consumption of the written value, a flag is set when any of the exposure or gain registers are written and is reset at the start of the next frame. This flag appears in *status0* register and may be monitored by the bus master. To speed up reading from this location, the sensor will repeatedly transmit the current value of the register, as long as the master acknowledges each byte read. In the next example, a *fine* exposure value of 0 is written, the status register is addressed (no data byte) and then constantly read until the master terminates the read message.

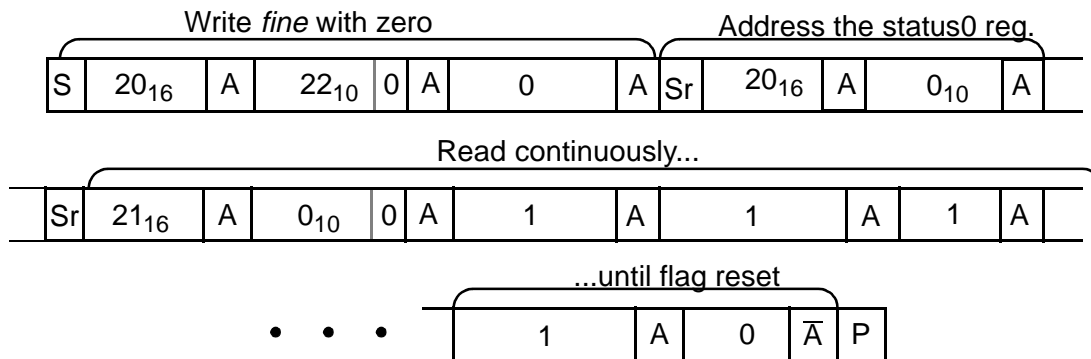

### Multiple location write

If the automatic increment bit is set, msb of the first data byte following the byte that contains the slave device address, then it is possible to write data bytes to many adjacent internal registers. A write to the black calibration parameters with their default values is shown in the following example.

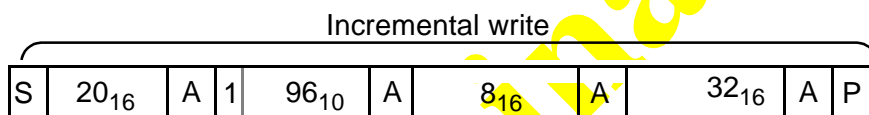

### Multiple location read

In the same manner, multiple locations can be read with a single read message. In this example the index is written first, to ensure the exposure related registers are addressed and then all seven are read

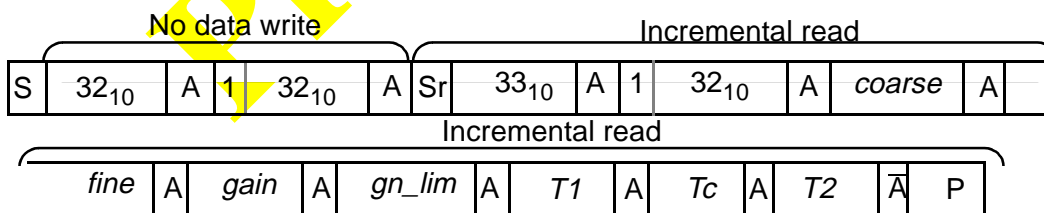

Note that a stop condition is not required after the negative acknowledge from the master.

## Serial Interface Autoload

VVL\_300 can be configured automatically at power-up with any user defined set of system parameters using the serial interface auto-load feature. An external E<sup>2</sup>PROM is used to store the configuration data.

Both shortly after power up and in response to an off-sensor 'soft' reset on SIN, the auto-loader will interrogate the E<sup>2</sup>PROM to determine whether or not valid data is present.

If no E<sup>2</sup> device is detected the auto-loader will shut-down and the serial interface register values will not be changed from their existing values.

If, however, an E<sup>2</sup> device is detected, the auto-loader will begin to load data into the parameter registers from starting from location zero in the E<sup>2</sup>.

The first byte is a register header code which determines the destination of the following data byte. This simple index & data format allows any sub-set of the VVL\_300 registers map to be configured at power-up and it allows them to be stored in the E<sup>2</sup> in any order.

If the auto-loader detects the 'end-of-PROM-contents' code 00h, it will then issue a STOP condition on the serial interface, raise a flag to indicate that the parameters have been loaded and close down.

Header	ROM contents
00h	ROM empty or end of data
xxh	Parameter header into which the following byte is to be written.

**E<sup>2</sup>PROM header bytes**

### Serial Interface Timing

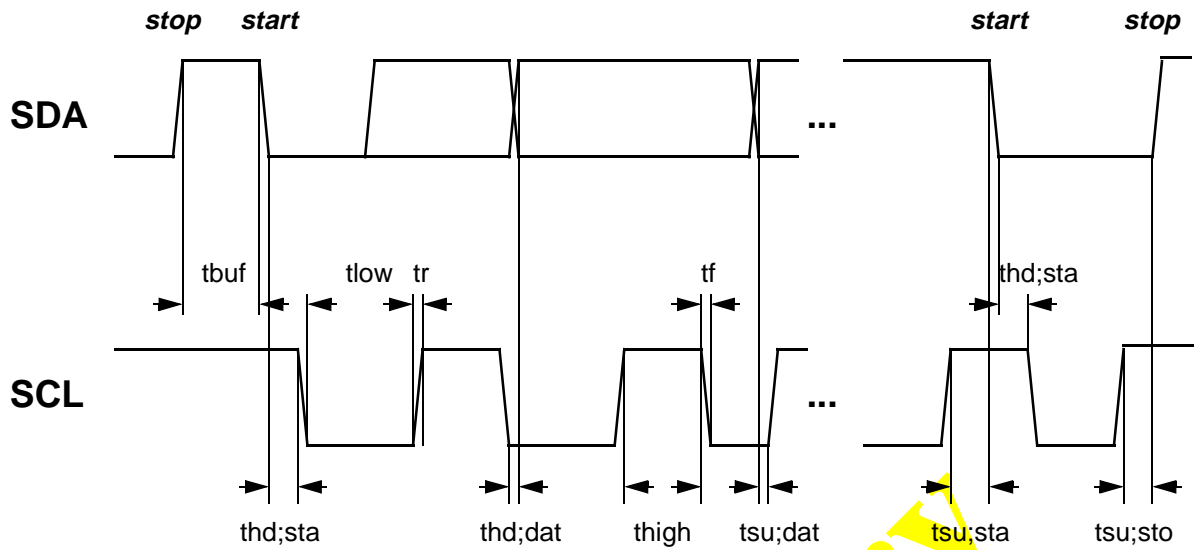

all values referred to the minimum input level (high) = 3.5V, and maximum input level (low) = 1.5V

### Serial Interface Timing Characteristics

Parameter	Symbol	Min.	Max.	Unit
SCL clock frequency	f <sub>scl</sub>	0	***	kHz
Bus free time between a <i>stop</i> and a <i>start</i>	t <sub>buf</sub>	***	-	us
Hold time for a repeated <i>start</i>	t <sub>hd;sta</sub>	***	-	us
LOW period of SCL	t <sub>low</sub>	***	-	us
HIGH period of SCL	t <sub>high</sub>	***	-	us
Set-up time for a repeated <i>start</i>	t <sub>su;sta</sub>	***	-	us
Data hold time	t <sub>hd;dat</sub>	***	-	us
Data Set-up time	t <sub>su;dat</sub>	***	-	ns
Rise time of SCL, SDA	t <sub>r</sub>	-	***	ns
Fall time of SCL, SDA	t <sub>f</sub>	-	***	ns
Set-up time for a <i>stop</i>	t <sub>su;sto</sub>	***	-	us
Capacitive load of each bus line (SCL, SDA)	C <sub>b</sub>	-	***	pF

### Serial Interface Timing Characteristics



EXAMPLE SUPPORT CIRCUIT

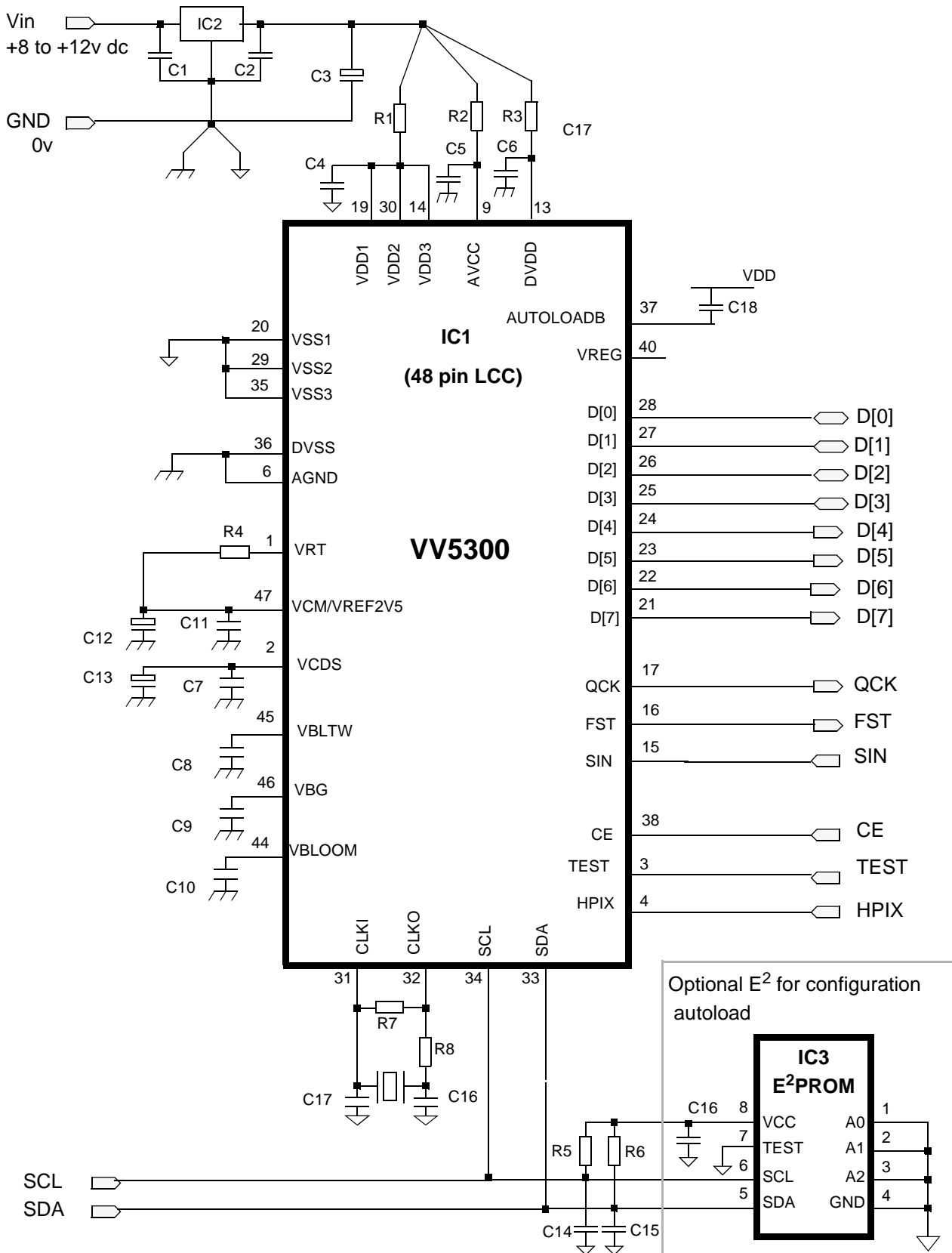

Component	Part No. / Provisional Value	Rating / Notes
IC1	VV5300	VVL camera chip (48 pin LCC)
IC2	7805	5V regulator
IC3	24C01	E2PROM SOIC (8 pin)
C3	10.0 $\mu$ F	
C1,C2, C4-C11	0.1 $\mu$ F	
C12, C13	4.7 $\mu$ F	
C14, C15	100pF	
C16, C17	22pF	
C18	1nF	
R1	0 $\Omega$	
R2	0 $\Omega$	
R3	0 $\Omega$	
R4	33 $\Omega$	
R5, R6	2k2 $\Omega$	
R7	1M $\Omega$	
R8	10 $\Omega$	

Preliminary

---

## VLSI VISION LIMITED

### UK Headquarters

Aviation House,  
31 Pinkhill,  
EDINBURGH  
EH12 7BF  
Scotland  
Tel:+44 (0) 131 539 7111  
Fax:+44 (0)131 539 7141  
eMail: info@vvl.co.uk

### USA Western Office

1190 Saratoga Ave.,  
Suite 180,  
SAN JOSE  
CA 95129 USA  
Tel: +1 408 556 1550  
Fax: +1 408 556 1564  
eMail: info@vvl.co.uk

### USA Eastern Office

571 West Lake Avenue,  
Suite 12,  
BAY HEAD  
NJ 08742 USA  
Tel: +1 732 701 1101  
Fax: +1 732 701 1102  
eMail: info@vvl.co.uk

VLSI Vision Ltd. reserves the right to make changes to its products and specifications at any time. Information furnished by VISION is believed to be accurate, but no responsibility is assumed by VISION for the use of said information, nor any infringements of patents or of any other third party rights which may result from said use. No license is granted by implication or otherwise under any patent or patent rights of any VISION group company.

© Copyright 1996, VLSI VISION

VLSI Vision agent or distributor
----------------------------------