

DOT MATRIX LCD 40-OUT SEGMENT DRIVER

■ GENERAL DESCRIPTION

The NJU6407CR is a serial input, 40-out segment driver for dot matrix LCDs, especially useful as extension driver for LCD controller drivers like NJU6408B.

It consists of 40-bit (two of 20-bit) shift register, 40-bit latch, and 40 high voltage LCD drivers.

The shift direction of each 20-bit shift register can be set independently to each other, consequently the efficient extension driver allocation according to the number of characters and easy wiring with the LCD panel can be performed.

As the 40-driver have 4 level voltage inputs to drive the LCD, adjustable driving voltage according to the LCD panel can be supplied from the external power source.

The pin configuration of NJU6407CR is mirror inverted allocation against the NJU6407C.

■ PACKAGE OUTLINE

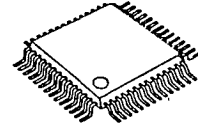

NJU6407CRF

■ FEATURES

- 40 Segment Drivers
- 40-bit Shift Register  
( Two of 20-bit Shift Registers )
- Shift Direction of each 20-bit  
Shift Registers Selection
- Two of Shift Direction Select Terminal
- Duty Ratio 1/8 to 1/16
- Fast Data Transmission ( Shift Clock 3.3 MHz min. )
- External Power Supply for LCD Driving Voltage
- LCD Driving Voltage ---  $V_{DD} - 3V \sim V_{DD} - 13.5V$
- Operating Voltage ---  $5V \pm 10\%$
- Mirror Inverted Pin Configuration Against the NJU6407C
- Package Outline --- QFP 56
- C-MOS Technology

5

■ BLOCK DIAGRAM

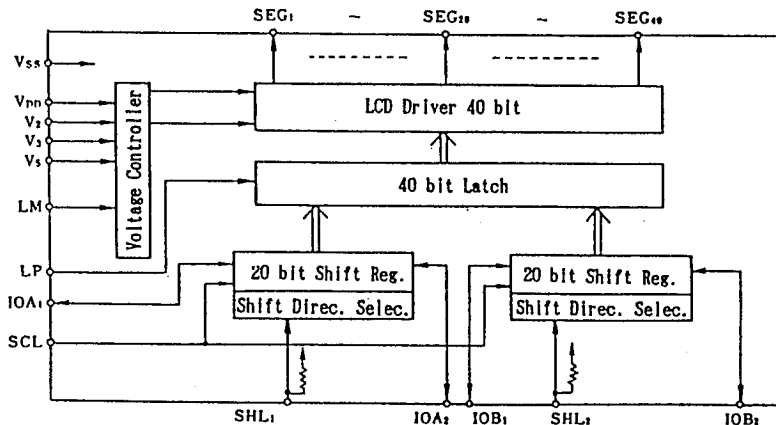

■ PIN CONFIGURATION

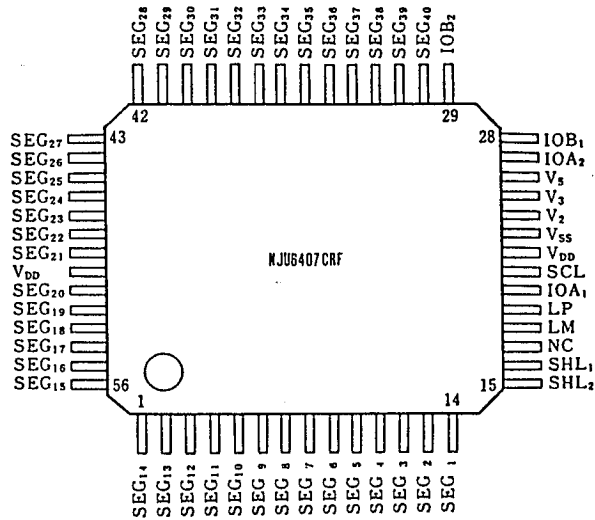

■ TERMINAL DESCRIPTION

No.	SYMBOL	F U N C T I O N
14~1 56~51 49~30	SEG <sub>1</sub> ~ SEG <sub>14</sub> SEG <sub>15</sub> ~ SEG <sub>20</sub> SEG <sub>21</sub> ~ SEG <sub>40</sub>	LCD segment driving terminal. Each terminal corresponds to each bit of shift register.
22, 50 23	V <sub>DD</sub> V <sub>SS</sub>	Power supply terminal (connect to the controller's V <sub>DD</sub> terminal) Power supply terminal (connect to the controller's V <sub>SS</sub> terminal)
29 28	IOB <sub>2</sub> IOB <sub>1</sub>	Data input/output terminals for 21st to 40th bits shift register. Display data is input (output) synchronized with clock pulse. Input or output is selected by SHL <sub>2</sub> terminal.
27 20	IOA <sub>2</sub> IOA <sub>1</sub>	Data input/output terminals for 1st to 20th bits shift register. Display data is input (output) synchronized with clock pulse. Input or output is selected by SHL <sub>1</sub> terminal.
26, 25 24	V <sub>5</sub> , V <sub>3</sub> V <sub>2</sub>	LCD driving power source terminals. V <sub>DD</sub> ≧ V <sub>2</sub> ≧ V <sub>3</sub> ≧ V <sub>5</sub>
21	SCL	Shift register clock pulse input terminal. The data is shifted in the shift register by the falling edge of the clock pulse. A data setup time and hold time are required between data input and SCL. Clock pulse rising time (T <sub>RS</sub> ) and falling time (T <sub>FS</sub> ) should be set less than 50ns respectively.
19	LP	Latch pulse input terminal. The data in the shift register is latched to the Latch by this signal. "H" : Data writing, "L" : Data latch
18	LM	Alternate signal input for LCD driving.
16	SHL <sub>1</sub>	Shift direction and input/output control terminal (Pull-up R). "H" or Open : Shift direction is from 1st bit to 20th bit. "L" : Shift direction is from 20th bit to 1st bit.
15	SHL <sub>2</sub>	Shift direction and input/output control terminal (Pull-up R). "H" or Open : Shift direction is from 21st bit to 40th bit. "L" : Shift direction is from 40th bit to 21st bit.
17	NC	Non connection.

5

**FUNCTIONAL DESCRIPTION**
**(1) Shift register control**

The 40-bit shift register is divided into two of 20-bit shift register.  
 The shift direction of each 20-bit shift register can be set independently to each other shown in below.

Control Terminal	Input	Shift Direction
SHL <sub>1</sub>	"H" or Open	IOA <sub>1</sub> → IOA <sub>2</sub>
	"L"	IOA <sub>1</sub> ← IOA <sub>2</sub>
SHL <sub>2</sub>	"H" or Open	IOB <sub>1</sub> → IOB <sub>2</sub>
	"L"	IOB <sub>1</sub> ← IOB <sub>2</sub>

(1-1) When the terminals SHL<sub>1</sub> and SHL<sub>2</sub> are "H" or open, the data shift from SEG<sub>1</sub> to SEG<sub>40</sub>.

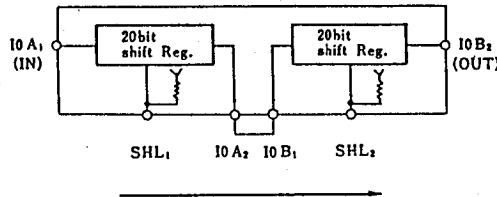

(1-2) When the terminals SHL<sub>1</sub> and SHL<sub>2</sub> are "L", the data shift from SEG<sub>40</sub> to SEG<sub>1</sub>.

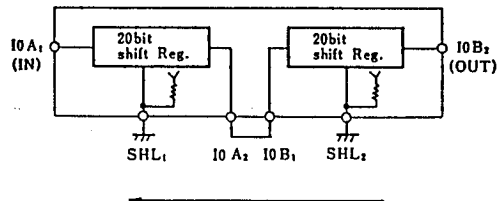

(1-3) Reversed shift direction to each other is also available.  
 SEG<sub>1</sub> → SEG<sub>20</sub> → SEG<sub>40</sub> → SEG<sub>21</sub> example is shown in below:

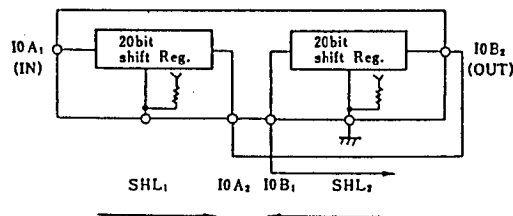

## (2) LCD driver output truth table.

Input Data	Selection/Non-selection	LM	Driver Output (SEG <sub>1</sub> to SEG <sub>40</sub> )
"H"	Selection	H	V <sub>5</sub>
		L	V <sub>DD</sub>
"L"	Non-selection	H	V <sub>3</sub>
		L	V <sub>2</sub>

## ■ ABSOLUTE MAXIMUM RATINGS

( Ta=25°C )

PARAMETER	SYMBOL	RATINGS	UNIT
Supply Voltage ( 1 )	V <sub>DD</sub>	- 0.3 ~ + 7.0	V
Supply Voltage ( 2 ) Note 1)	V <sub>DD</sub> ~ V <sub>5</sub>	V <sub>DD</sub> -13.5 ~ V <sub>DD</sub> +0.3	V
Input Voltage	V <sub>IN</sub>	- 0.3 ~ V <sub>DD</sub> +0.3	V
Operating Temperature	T <sub>OP</sub>	- 30 ~ + 80	°C
Storage Temperature	T <sub>STG</sub>	- 55 ~ + 150	°C

 Note 1) The relation : V<sub>DD</sub> ≥ V<sub>2</sub> ≥ V<sub>3</sub> ≥ V<sub>5</sub> must be maintained.

## ■ ELECTRICAL CHARACTERISTICS

• DC Characteristics

 ( V<sub>DD</sub>=5V±10% , Ta=-20 ~ +75°C )

PARAMETER	SYMBOL	CONDITIONS		MIN	TYP	MAX	UNIT
Input Voltage	V <sub>IH</sub>	LM, LP, SHL <sub>1</sub> , SHL <sub>2</sub> Terminals		0.8V <sub>DD</sub>		V <sub>DD</sub>	V
	V <sub>IL</sub>					0.2V <sub>DD</sub>	
Input Current	I <sub>IH1</sub>	V <sub>IH</sub> =V <sub>DD</sub>	LM, LP Terminals			1	μA
	I <sub>IL1</sub>	V <sub>IL</sub> =0V				- 1	
	I <sub>IH2</sub>	V <sub>IH</sub> =V <sub>DD</sub>	SHL <sub>1</sub> , SHL <sub>2</sub> Terminals			1	
	I <sub>IL2</sub>	V <sub>IL</sub> =0V		- 10	- 15	- 25	
Output Voltage	V <sub>OH</sub>	I <sub>O</sub> =- 40μA	IOA <sub>1</sub> , IOA <sub>2</sub> , IOB <sub>1</sub> , IOB <sub>2</sub> Terminals	4.2			V
	V <sub>OL</sub>	I <sub>O</sub> = 400μA				0.4	
Driver On-resistance	R <sub>ON</sub>	I <sub>d</sub> =0.05mA	SEG <sub>1</sub> ~ SEG <sub>40</sub> Terminals			30	kΩ
Operating Current	I <sub>DD</sub>	SCL=1.5MHz, LM,LP=130us cycle No Load			0.6	1.0	mA
LCD Driving Voltage	V <sub>LCD</sub>	V <sub>DD</sub> - V <sub>5</sub>		V <sub>DD</sub> -3.0		V <sub>DD</sub> -13.5	V

## • AC Characteristics

PARAMETER	SYMBOL	CONDITIONS	MIN	TYP	MAX	UNIT
Propagation Delay Time	$T_{PLH(HL)}$				250	ns
Maximum Operating Frequency	$f_{SCL}$	Duty = 50 %	3.3			MHz
SCL Pulse Width	$T_{WS}$		125			ns
LP Pulse Width	$T_{WL}$		125			ns
Set up Time	$T_{SET}$		50			ns
SCL → LP Time	$T_{SL}$		250			ns
LP → SCL Time	$T_{LS}$		0			ns
Data Hold Time	$T_{HOLD}$		50			ns
SCL Rise, Fall Time	$T_{RS}, T_{FS}$				50	ns
LP Rise, Fall Time	$T_{RL}, T_{FL}$				1	us

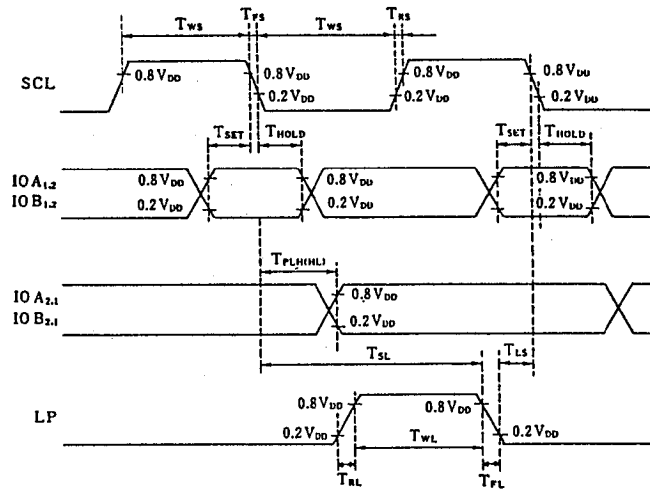

## ■ TIMING CHART

1/5 Bias, 1/16 Duty Ratio

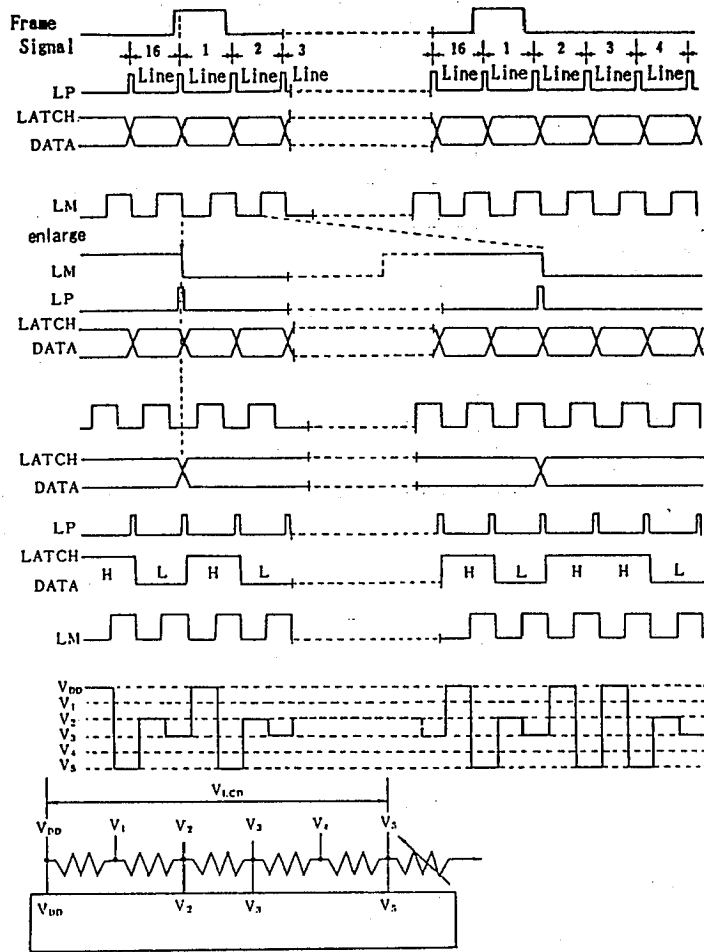

5

## ■ SEGMENT SIGNAL OUTPUT TIMING

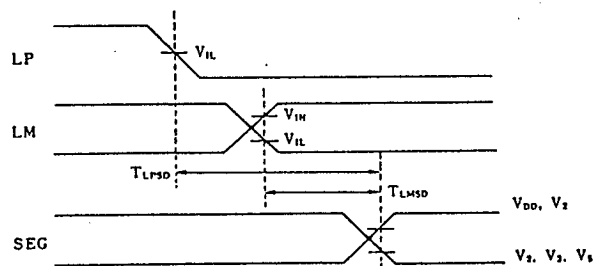

PARAMETER	SYMBOL	CONDITIONS	MIN	TYP	MAX	UNIT
LP - SEG Output Delay Time	$T_{LP\text{SD}}$	$C_L = 100\text{pF}$			4.5	us
LM - SEG Output Delay Time	$T_{LM\text{SD}}$	$C_L = 100\text{pF}$			4.5	

■ LCD DRIVING WAVEFORM EXAMPLE

1/5 Bias, 1/16 Duty Ratio

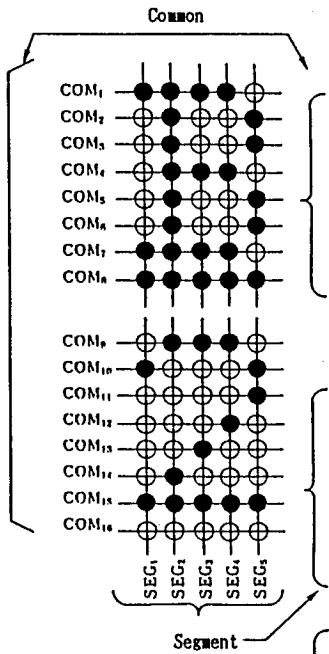

Common COM<sub>1</sub>-  
Segment SEG<sub>1</sub>  
(Selection  
Waveform)

Common COM<sub>2</sub>-  
Segment SEG<sub>1</sub>  
(Non-selection  
Waveform)

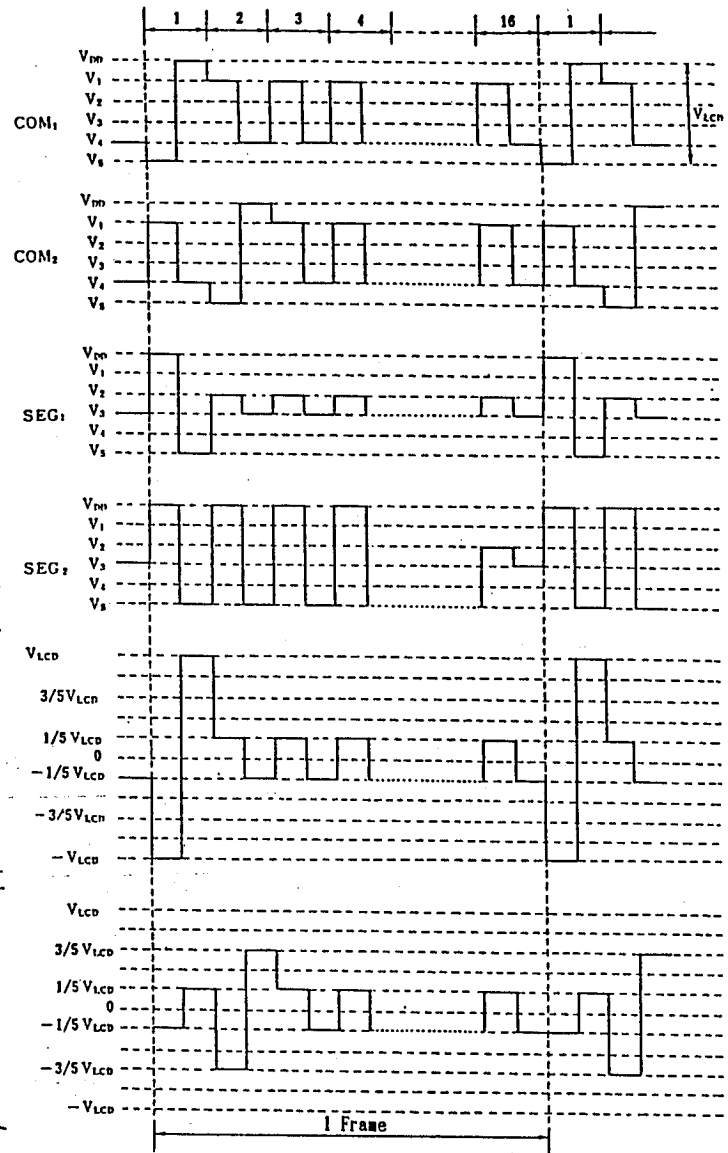

## ■ APPLICATION CIRCUITS

(1) 16-character 2-line Display Example ( Combine with NJU6408B )

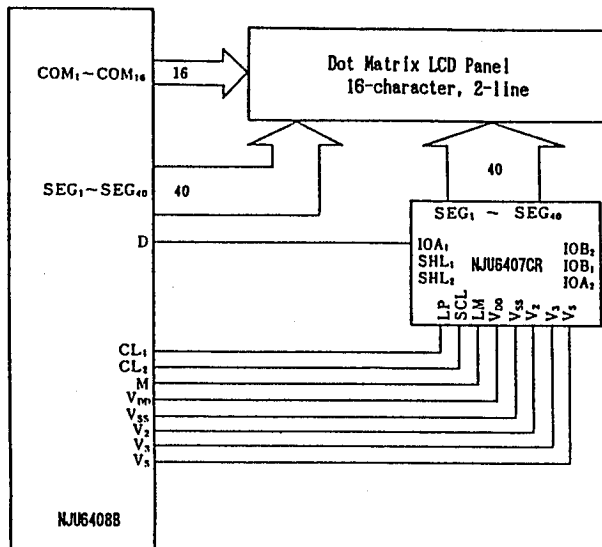

(2) 24-character 2-line Display Example ( NJU6408B + NJU6407CR x 2 )

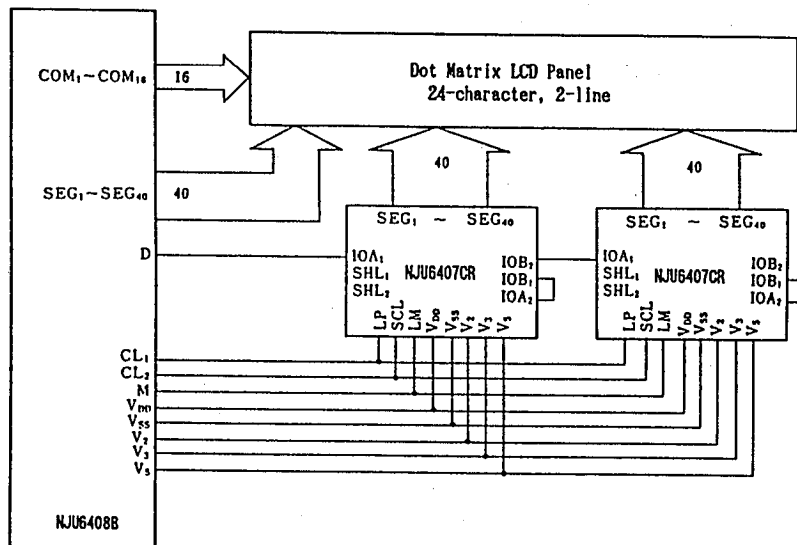



(3) 40-character 2-line Display Example ( NJU6408B + NJU6407CR x 4 )

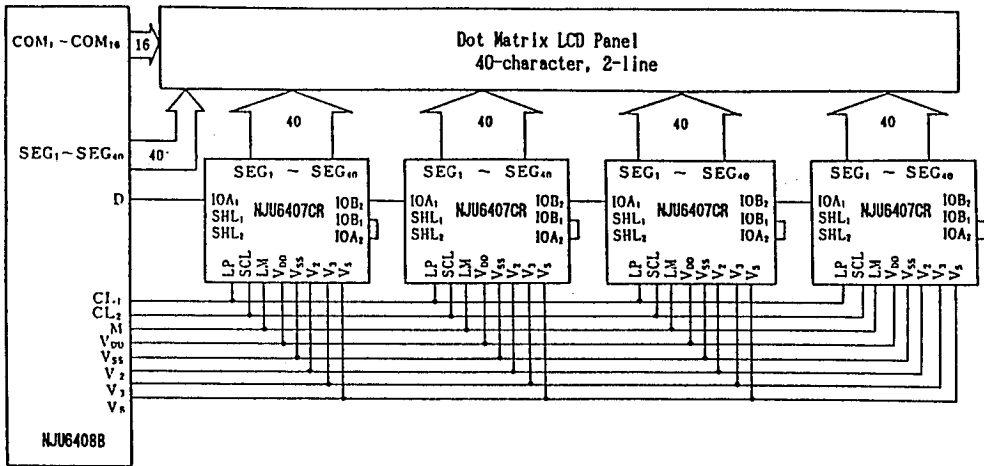

## MEMO

[CAUTION]

The specifications on this databook are only given for information, without any guarantee as regards either mistakes or omissions. The application circuits in this databook are described only to show representative usages of the product and not intended for the guarantee or permission of any right including the industrial rights.