

DATA SHEET

74LV123

Dual retriggerable monostable
multivibrator with reset

Product specification
Supersedes data of 1997 Feb 04
IC24 Data Handbook

1998 Apr 20

Dual retriggerable monostable multivibrator with reset

74LV123

FEATURES

- Optimized for Low Voltage applications: 1.0 to 5.5V
- Accepts TTL input levels between $V_{CC} = 2.7V$ and $V_{CC} = 3.6V$
- Typical V_{OLP} (output ground bounce) $< 0.8V$ @ $V_{CC} = 3.3V$, $T_{amb} = 25^{\circ}C$
- Typical V_{OHV} (output V_{OH} undershoot) $> 2V$ @ $V_{CC} = 3.3V$, $T_{amb} = 25^{\circ}C$
- DC triggered from active HIGH or active LOW inputs
- Retriggerable for very long pulses up to 100% duty factor
- Direct reset terminates output pulses
- Schmitt-trigger action on all inputs except for the reset input
- Output capability: standard (except for nR_{EXT}/C_{EXT})
- I_{CC} category: MSI

DESCRIPTION

The 74LV123 is a low-voltage Si-gate CMOS device and is pin and function compatible with the 74HC/HCT123.

The 74LV123 is a dual retriggerable monostable multivibrator with output pulse width control by three methods. The basic pulse time is programmed by selection of an external resistor (R_{EXT}) and capacitor (C_{EXT}). They are normally connected as shown in Figure 1. Once triggered, the basic output pulse width may be extended by retriggering the gated active LOW-going edge input ($n\bar{A}$) or the active HIGH-going edge input (nB). By repeating this process, the output pulse period ($nQ = HIGH$, $n\bar{Q} = LOW$) can be made as long as desired. Alternatively, an output delay can be terminated at any time by a LOW-going edge on input $n\bar{R}_D$, which also inhibits the triggering. Figures 1 and 2 illustrate pulse control by retriggering and early reset. The basic output pulse width is essentially determined by the values of the external timing components R_{EXT} and C_{EXT} . For pulse width when $C_{EXT} < 10000pF$, see Figure 5. When $C_{EXT} > 10,000pF$, the typical output pulse width is defined as: $t_W = 0.45 \times R_{EXT} \times C_{EXT}$ (typ.), where t_W = pulse width in ns; R_{EXT} = external resistor in $K\Omega$; and C_{EXT} = external capacitor in pF. Schmitt-trigger action in the $n\bar{A}$ and nB inputs makes the circuit highly tolerant of slower input rise and fall times.

QUICK REFERENCE DATA

GND = 0V; $T_{amb} = 25^{\circ}C$; $t_r = t_f \leq 2.5$ ns

SYMBOL	PARAMETER	CONDITIONS	TYPICAL	UNIT
t_{PHL}/t_{PLH}	Propagation delay $n\bar{A}$, nB to nQ , $n\bar{Q}$ $n\bar{R}_D$ to nQ , $n\bar{Q}$	$C_L = 15pF$ $V_{CC} = 3.3V$ $R_{EXT} = 5K\Omega$ $C_{EXT} = 0pF$	25 20	ns ns
C_I	Input capacitance		3.5	pF
C_{PD}	Power dissipation capacitance per monostable	$V_{CC} = 3.3V$, $V_I = GND$ to V_{CC}^1	60	pF

NOTES:

- C_{PD} is used to determine the dynamic power dissipation (P_D in μW)
 $P_D = C_{PD} \times V_{CC}^2 \times f_i + \Sigma (C_L \times V_{CC}^2 \times f_o)$ where:
 f_i = input frequency in MHz; C_L = output load capacitance in pF;
 f_o = output frequency in MHz; V_{CC} = supply voltage in V;
 $\Sigma (C_L \times V_{CC}^2 \times f_o)$ = sum of the outputs.

ORDERING INFORMATION

PACKAGES	TEMPERATURE RANGE	OUTSIDE NORTH AMERICA	NORTH AMERICA	PKG. DWG. #
16-Pin Plastic DIL	-40°C to +125°C	74LV123 N	74LV123 N	SOT38-1
16-Pin Plastic SO	-40°C to +125°C	74LV123 D	74LV123 D	SOT109-1
16-Pin Plastic SSOP Type II	-40°C to +125°C	74LV123 DB	74LV123 DB	SOT338-1
16-Pin Plastic TSSOP Type I	-40°C to +125°C	74LV123 PW	74LV123PW DH	SOT403-1

Dual retriggerable monostable multivibrator with reset

74LV123

PIN CONFIGURATION

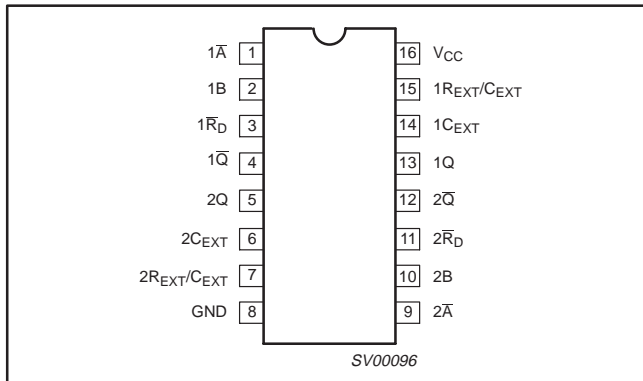

PIN DESCRIPTION

PIN NUMBER	SYMBOL	FUNCTION
1,9	1A, 2A	Trigger inputs (negative-edge triggered)
2,10	1B, 2B	Trigger inputs (positive-edge triggered)
3,11	1RD, 2RD	Direct reset LOW and trigger action at positive edge
4, 12	1Q, 2Q	Outputs (active LOW)
7	2REXT/CEXT	External resistor/capacitor connection
8	GND	Ground (0V)
13, 5	1Q, 2Q	Outputs (active HIGH)
14, 6	1CEXT, 2CEXT	External capacitor connection
15	1REXT/CEXT	External resistor/capacitor connection
16	VCC	Positive supply voltage

LOGIC SYMBOL (IEEE/IEC)

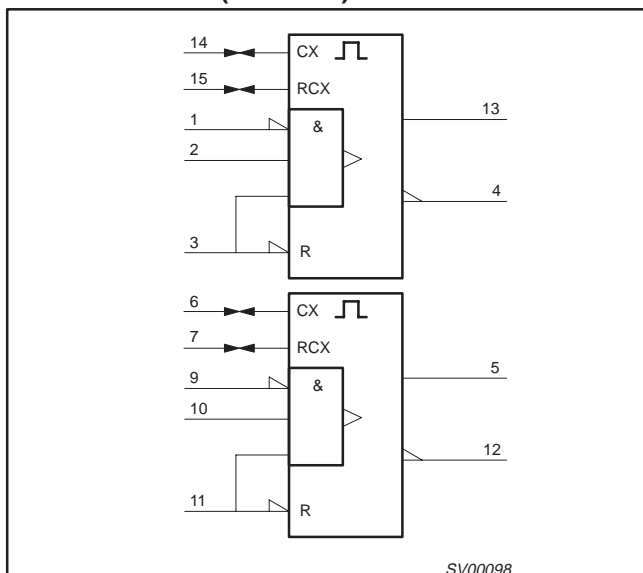

LOGIC SYMBOL

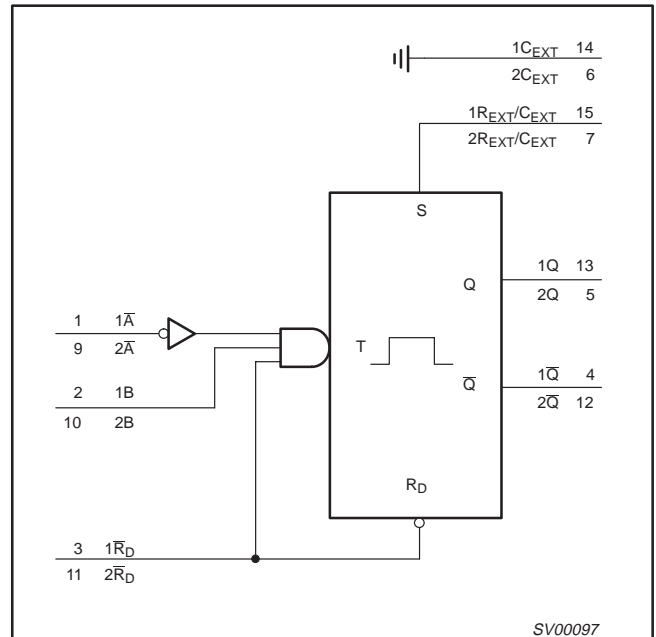

FUNCTIONAL DIAGRAM

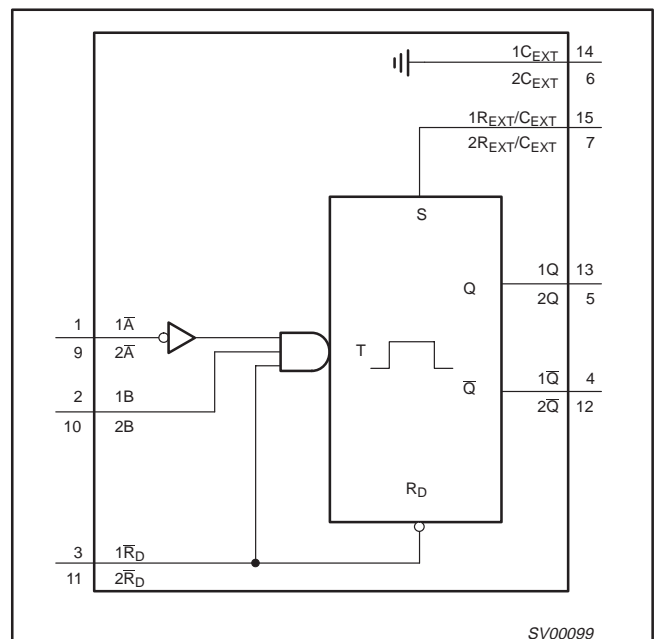

Dual retriggerable monostable multivibrator with reset

74LV123

LOGIC DIAGRAM

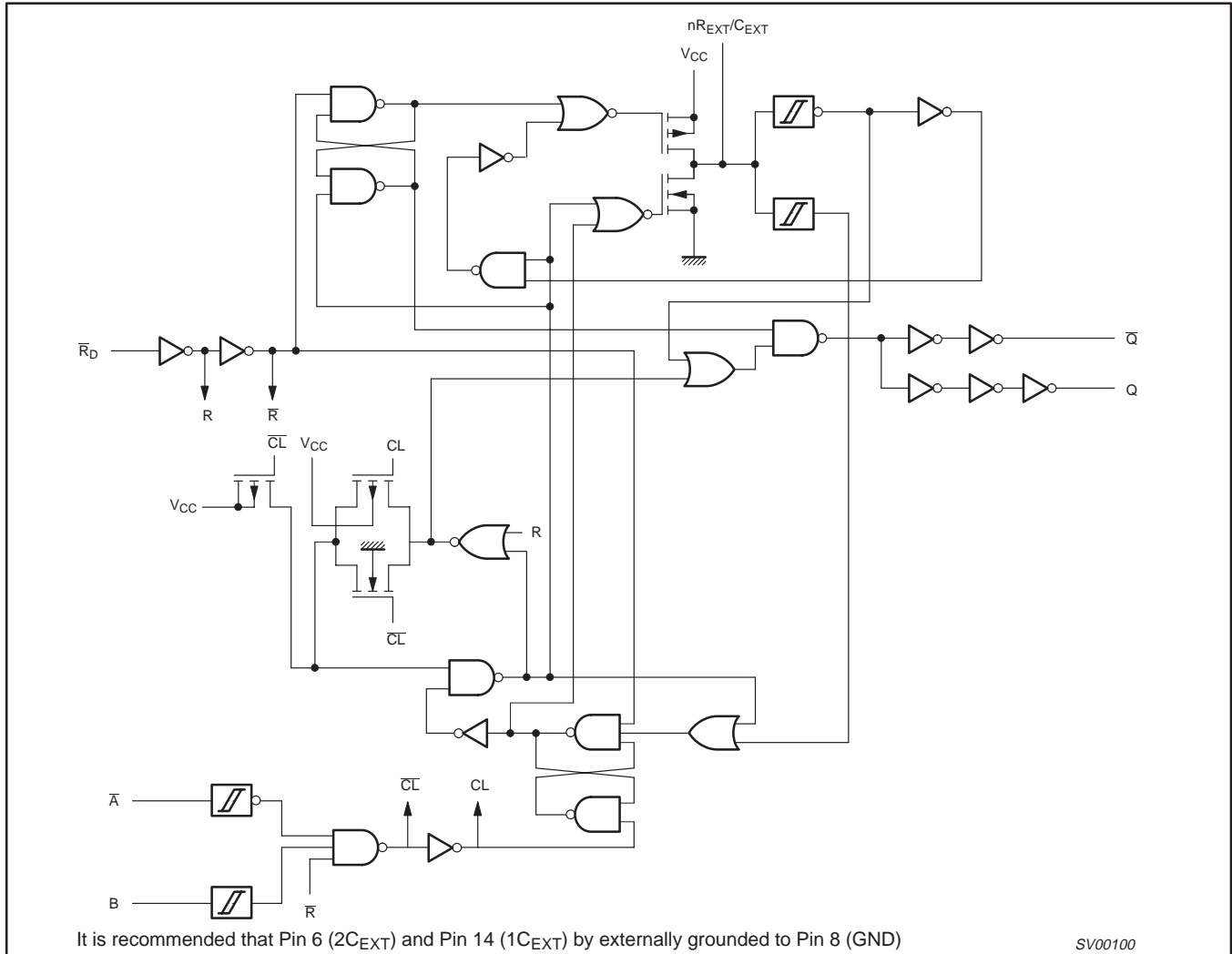

FUNCTION TABLE

INPUTS			OUTPUTS	
nR _D	nA	nB	nQ	nQ̄
L	X	X	L	H
X	H	X	L*	H*
X	X	L	L*	H*
H	L	↑	⎓	⎓
H	↓	H	⎓	⎓
↑	L	H	⎓	⎓

NOTES:

* If the monostable was triggered before this condition was established, the pulse will continue as programmed.

H = HIGH voltage level

L = LOW voltage level

X = don't care

↑ = LOW-to-HIGH transition

↓ = HIGH-to-LOW transition

⎓ = one HIGH level output pulse

⎓ = one LOW level output pulse

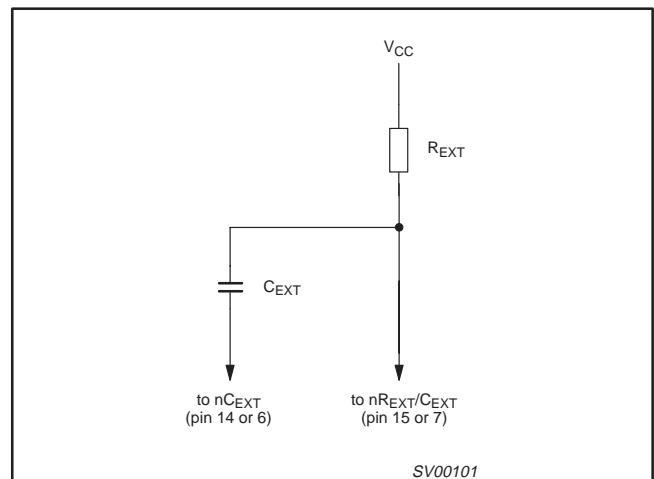

Figure 1. Timing component connection

Dual retriggerable monostable multivibrator with reset

74LV123

RECOMMENDED OPERATING CONDITIONS

SYMBOL	PARAMETER	CONDITIONS	MIN	TYP	MAX	UNIT
V_{CC}	DC supply voltage	See Note ¹	1.0	3.3	5.5	V
V_I	Input voltage		0	–	V_{CC}	V
V_O	Output voltage		0	–	V_{CC}	V
T_{amb}	Operating ambient temperature range in free air	See DC and AC characteristics	–40 –40		+85 +125	°C
t_r, t_f	Input rise and fall times except for Schmitt-trigger inputs	$V_{CC} = 1.0V$ to $2.0V$ $V_{CC} = 2.0V$ to $2.7V$ $V_{CC} = 2.7V$ to $3.6V$ $V_{CC} = 3.6V$ to $5.5V$	– – – –	– – – –	500 200 100 50	ns/V

NOTE:

1. The LV is guaranteed to function down to $V_{CC} = 1.0V$ (input levels GND or V_{CC}); DC characteristics are guaranteed from $V_{CC} = 1.2V$ to $V_{CC} = 5.5V$.

ABSOLUTE MAXIMUM RATINGS^{1, 2}

In accordance with the Absolute Maximum Rating System (IEC 134).

Voltages are referenced to GND (ground = 0V).

SYMBOL	PARAMETER	CONDITIONS	RATING	UNIT
V_{CC}	DC supply voltage		–0.5 to +7.0	V
$\pm I_{IK}$	DC input diode current	$V_I < -0.5$ or $V_I > V_{CC} + 0.5V$	20	mA
$\pm I_{OK}$	DC output diode current	$V_O < -0.5$ or $V_O > V_{CC} + 0.5V$	50	mA
$\pm I_O$	DC output source or sink current – standard outputs	$-0.5V < V_O < V_{CC} + 0.5V$	25	mA
$\pm I_{GND},$ $\pm I_{CC}$	DC V_{CC} or GND current for types with – standard outputs		50	mA
T_{stg}	Storage temperature range		–65 to +150	°C
P_{TOT}	Power dissipation per package – plastic DIL – plastic mini-pack (SO) – plastic shrink mini-pack (SSOP and TSSOP)	for temperature range: –40 to +125°C above +70°C derate linearly with 12 mW/K above +70°C derate linearly with 8 mW/K above +60°C derate linearly with 5.5 mW/K	750 500 500	mW

NOTES:

- Stresses beyond those listed may cause permanent damage to the device. These are stress ratings only and functional operation of the device at these or any other conditions beyond those indicated under “recommended operating conditions” is not implied. Exposure to absolute-maximum-rated conditions for extended periods may affect device reliability.
- The input and output voltage ratings may be exceeded if the input and output current ratings are observed.

Dual retriggerable monostable multivibrator with reset

74LV123

DC ELECTRICAL CHARACTERISTICS

Over recommended operating conditions. Voltages are referenced to GND (ground = 0V).

SYMBOL	PARAMETER	TEST CONDITIONS	LIMITS					UNIT
			-40°C to +85°C			-40°C to +125°C		
			MIN	TYP ¹	MAX	MIN	MAX	
V _{IH}	HIGH level Input voltage	V _{CC} = 1.2V	0.9			0.9		V
		V _{CC} = 2.0V	1.4			1.4		
		V _{CC} = 2.7 to 3.6V	2.0			2.0		
		V _{CC} = 4.5 to 5.5V	0.7 * V _{CC}			0.7 * V _{CC}		
V _{IL}	LOW level Input voltage	V _{CC} = 1.2V			0.3		0.3	V
		V _{CC} = 2.0V			0.6		0.6	
		V _{CC} = 2.7 to 3.6V			0.8		0.8	
		V _{CC} = 4.5 to 5.5			0.3 * V _{CC}		0.3 * V _{CC}	
V _{OH}	HIGH level output voltage; all outputs	V _{CC} = 1.2V; V _I = V _{IH} or V _{IL} ; -I _O = 100μA		1.2				V
		V _{CC} = 2.0V; V _I = V _{IH} or V _{IL} ; -I _O = 100μA	1.8	2.0		1.8		
		V _{CC} = 2.7V; V _I = V _{IH} or V _{IL} ; -I _O = 100μA	2.5	2.7		2.5		
		V _{CC} = 3.0V; V _I = V _{IH} or V _{IL} ; -I _O = 100μA	2.8	3.0		2.8		
		V _{CC} = 4.5V; V _I = V _{IH} or V _{IL} ; -I _O = 100μA	4.3	4.5		4.3		
V _{OH}	HIGH level output voltage; STANDARD outputs	V _{CC} = 3.0V; V _I = V _{IH} or V _{IL} ; -I _O = 6mA	2.40	2.82		2.20		V
		V _{CC} = 4.5V; V _I = V _{IH} or V _{IL} ; -I _O = 12mA	3.60	4.20		3.50		
V _{OL}	LOW level output voltage; all outputs	V _{CC} = 1.2V; V _I = V _{IH} or V _{IL} ; I _O = 100μA		0				V
		V _{CC} = 2.0V; V _I = V _{IH} or V _{IL} ; I _O = 100μA		0	0.2		0.2	
		V _{CC} = 2.7V; V _I = V _{IH} or V _{IL} ; I _O = 100μA		0	0.2		0.2	
		V _{CC} = 3.0V; V _I = V _{IH} or V _{IL} ; I _O = 100μA		0	0.2		0.2	
		V _{CC} = 4.5V; V _I = V _{IH} or V _{IL} ; I _O = 100μA		0	0.2		0.2	
V _{OL}	LOW level output voltage; STANDARD outputs	V _{CC} = 3.0V; V _I = V _{IH} or V _{IL} ; I _O = 6mA		0.25	0.40		0.50	V
		V _{CC} = 4.5V; V _I = V _{IH} or V _{IL} ; I _O = 12mA		0.35	0.55		0.65	
I _I	Input leakage current	V _{CC} = 5.5V; V _I = V _{CC} or GND			1.0		1.0	μA
I _{CC}	Quiescent supply current; MSI	V _{CC} = 5.5V; V _I = V _{CC} or GND; I _O = 0			20.0		160	μA
ΔI _{CC}	Additional quiescent supply current	V _{CC} = 2.7V to 3.6V; V _I = V _{CC} - 0.6V			500		850	μA

NOTES:

1. All typical values are measured at T_{amb} = 25°C.

Dual retriggerable monostable multivibrator
with reset

74LV123

AC CHARACTERISTICS

GND = 0V; $t_r = t_f \leq 2.5\text{ns}$; $C_L = 50\text{pF}$; $R_L = 1\text{K}\Omega$

SYMBOL	PARAMETER	WAVEFORM	CONDITION	LIMITS					UNIT
				-40 to +85°C			-40 to +125°C		
				V _{CC} (V)	MIN	TYP ¹	MAX	MIN	
t _{PHL}	Propagation delay nR _D , nA, nB, to nQ	Figure 3 C _{EXT} = 0pF R _{EXT} = 5KΩ	1.2		120				ns
			2.0		40	76		92	
			2.7		30	56		68	
			3.0 to 3.6		25 ²	48		57	
			4.5 to 5.5		18 ²	40		46	
t _{PLH}	Propagation delay nR _D , nA, nB, to nQ	Figure 3 C _{EXT} = 0pF R _{EXT} = 5KΩ	1.2		120				ns
			2.0		40	76		92	
			2.7		30	56		68	
			3.0 to 3.6		25 ²	48		57	
			4.5 to 5.5		18 ²	40		46	
t _{PHL}	Propagation delay nR _D to nQ (reset)	Figure 3 C _{EXT} = 0pF R _{EXT} = 5KΩ	1.2		100				ns
			2.0		30	57		68	
			2.7		23	43		51	
			3.0 to 3.6		20 ²	38		45	
			4.5 to 5.5		14 ²	31		36	
t _{PLH}	Propagation delay nR _D to nQ (reset)	Figure 3 C _{EXT} = 0pF R _{EXT} = 5KΩ	1.2		100				ns
			2.0		30	57		68	
			2.7		23	43		51	
			3.0 to 3.6		20 ²	38		45	
			4.5 to 5.5		14 ²	31		36	
t _w	Trigger pulse width nA = LOW	Figure 3	2.0	30	5		40		ns
			2.7	25	3.5		30		
			3.0 to 3.6	20	3.0 ²		25		
			4.5 to 5.5	15	2.5 ²		20		
t _w	Trigger pulse width nB = HIGH	Figure 3	2.0	30	13		40		ns
			2.7	25	8		30		
			3.0 to 3.6	20	7 ²		25		
			4.5 to 5.5	15	5 ²		20		
t _w	Reset pulse width nR _D = LOW	Figure 2	2.0	35	6		45		ns
			2.7	30	5		40		
			3.0 to 3.6	25	4 ²		30		
			4.5 to 5.5	20	3 ²		25		
t _w	Output pulse width nQ = HIGH nQ = LOW	Figures 1, 2 C _{EXT} = 100nF R _{EXT} = 10KΩ	2.0		470				μs
			2.7		460				
			3.0 to 3.6		450 ²				
			4.5 to 5.5		430 ²				
t _w	Output pulse width nQ = HIGH nQ = LOW	Figures 1, 2 C _{EXT} = 0pF R _{EXT} = 5KΩ	2.0		100				ns
			2.7		90				
			3.0 to 3.6		80 ²				
			4.5 to 5.5		70 ²				
t _{rt}	Retrigger time nA, nB	Figure 1 C _{EXT} = 0pF R _{EXT} = 5KΩ	2.0		70				ns
			2.7		55				
			3.0 to 3.6		45 ²				
			4.5 to 5.5		40 ²				

Dual retriggerable monostable multivibrator with reset

74LV123

AC CHARACTERISTICS (Continued)

GND = 0V; $t_r = t_f \leq 2.5\text{ns}$; $C_L = 50\text{pF}$; $R_L = 1\text{K}\Omega$

SYMBOL	PARAMETER	WAVEFORM	CONDITION	LIMITS					UNIT
				-40 to +85°C			-40 to +125°C		
				V _{CC} (V)	MIN	TYP	MAX	MIN	
R _{EXT}	External timing resistor	Figure 5	1.2	10		1000			KΩ
			2.0	5		1000			
			2.7	3		1000			
			3.0 to 3.6	2		1000			
			4.5 to 5.5	2		1000			
C _{EXT}	External timing capacitor	Figure 5 ³	1.2	No limits					pF
			2.0						
			2.7						
			3.0 to 3.6						
			4.5 to 5.5						

NOTES:

- Unless otherwise stated, all typical values are at T_{amb} = 25°C.
- Typical value measured at V_{CC} = 3.3V.
- Typical value measured at V_{CC} = 5.0V.
- For other R_{EXT} and C_{EXT} combinations see Figure 5.
 if C_{EXT} > 10 nF, the next formula is valid:
 $t_W = K \times R_{EXT} \times C_{EXT}$ (typ.)
 where, t_W = output pulse width in ns;
 R_{EXT} = external resistor in KΩ; C_{EXT} = external capacitor in pF;
 K = constant = 0.45 for V_{CC} = 5.0V and 0.48 for V_{CC} = 2.0V.
 The inherent test jig and pin capacitance at pins 15 and 7 (nR_{EXT}/C_{EXT}) is approximately 7 pF.
- The time to retrigger the monostable multivibrator depends on the values of R_{EXT} and C_{EXT}.
 The output pulse width will only be extended when the time between the active-going edges of the trigger pulses meets the minimum retrigger time.
 If C_{EXT} > 10 pF, the next formula (at V_{CC} = 5.0V) for the set-up time of a retrigger pulse is valid:
 $t_{rt} = 30 + 0.19R \times C^{-9} + 13 \times R^{1.05}$ (typ.)
 where, t_{rt} = retrigger time in ns;
 C_{EXT} = external capacitor in pF;
 R_{EXT} = external resistor in KΩ.
 The inherent test jig and pin capacitance at pins 15 and 7 (nR_{EXT}/C_{EXT}) is approximately 7 pF.
- When the device is powered up, initiate the device via a reset pulse, when C_{EXT} < 50pF.

AC WAVEFORMS

V_M = 1.5V at V_{CC} ≥ 2.7V; V_M = 0.5 V_{CC} at V_{CC} < 2.7V; V_{OL} and V_{OH} are the typical output voltage drop that occur with the output load.

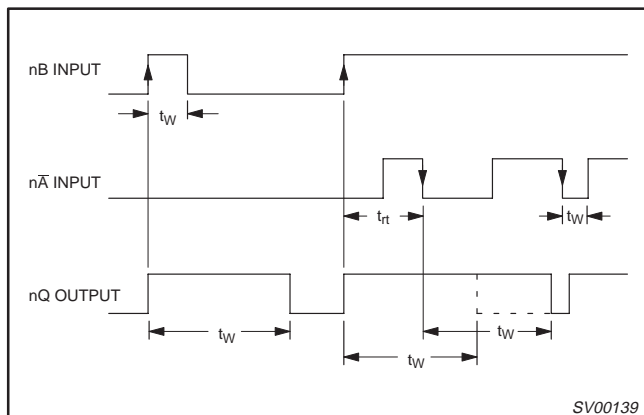

Figure 1. Output pulse control using retrigger pulse;
nR_D = HIGH.

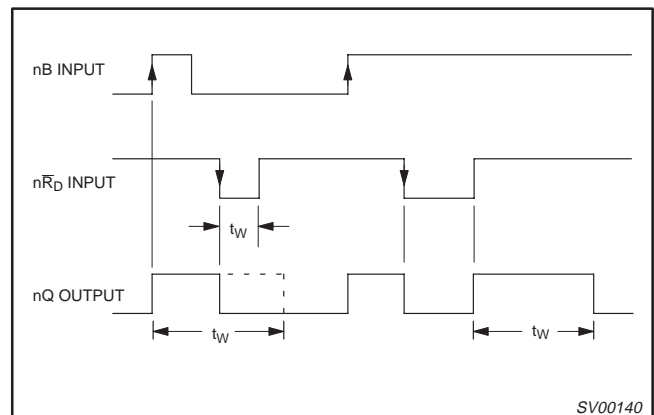
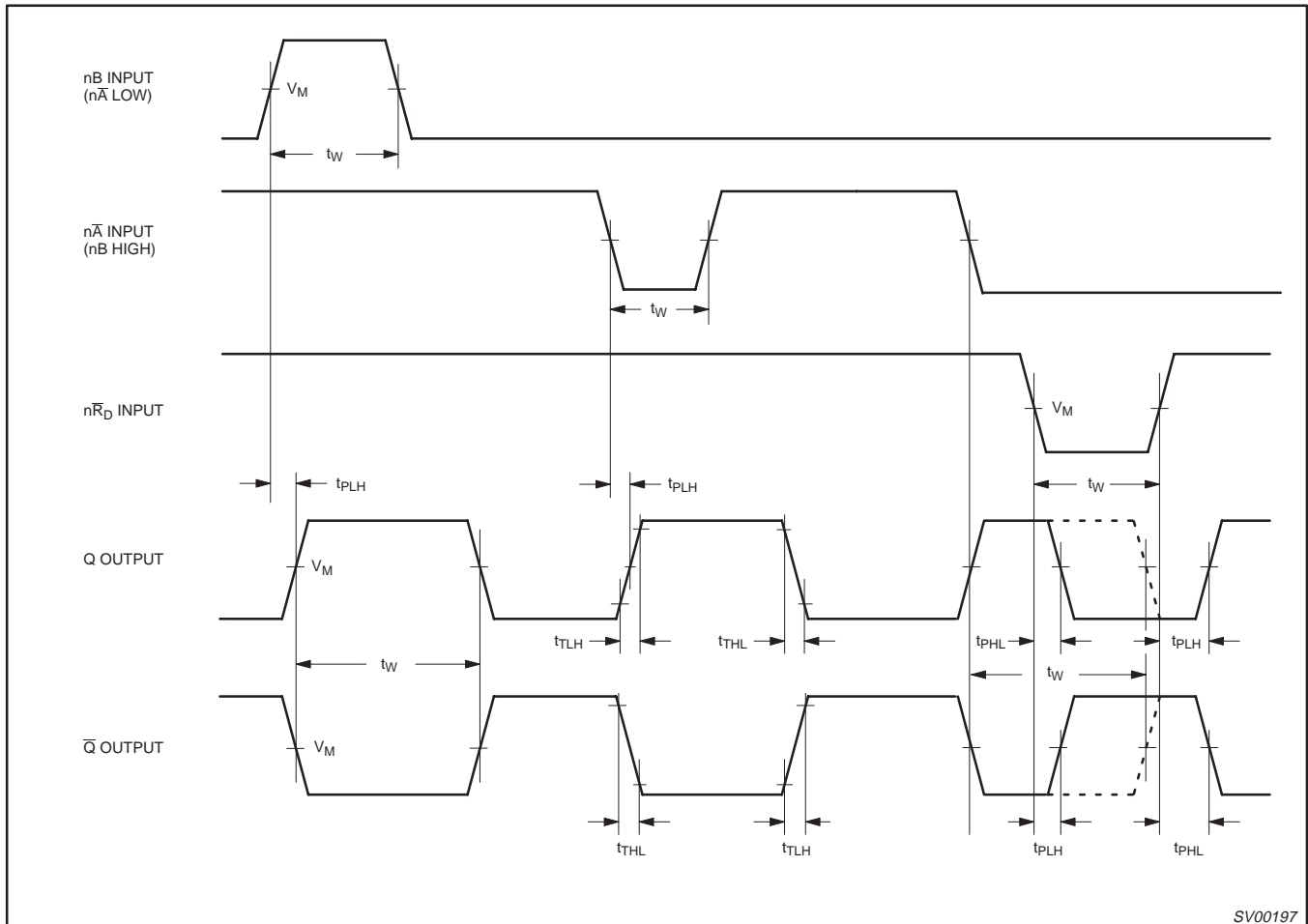

Figure 2. Output pulse control using reset input nR_D;
nA = LOW.

Dual retriggerable monostable multivibrator with reset

74LV123



SV00197

Figure 3. Input ($n\bar{A}$, nB , $n\bar{R}_D$) to output (nQ , $n\bar{Q}$) propagation delays, the output transition times, and the input and output pulse widths.

Dual retriggerable monostable multivibrator with reset

74LV123

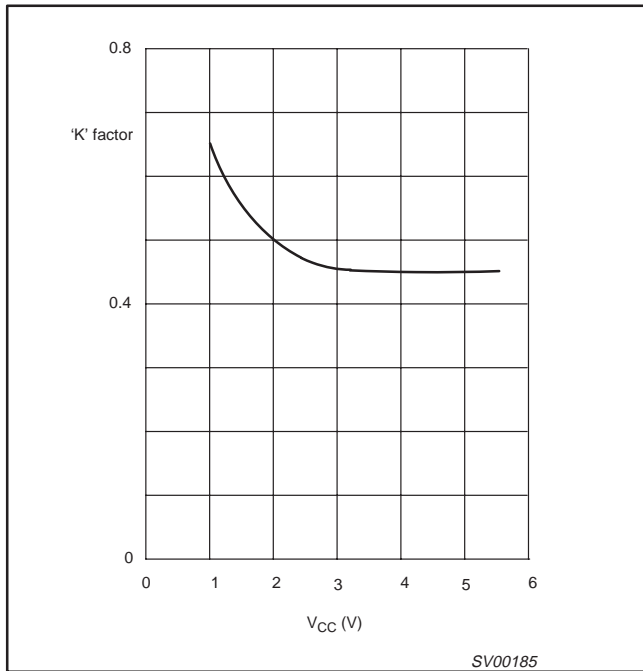

Figure 4. HCT typical “k” factor as a function of V_{CC} :
 $C_X = 10 \text{ nF}$; $R_X = 10 \text{ k}\Omega$ to $100 \text{ k}\Omega$.

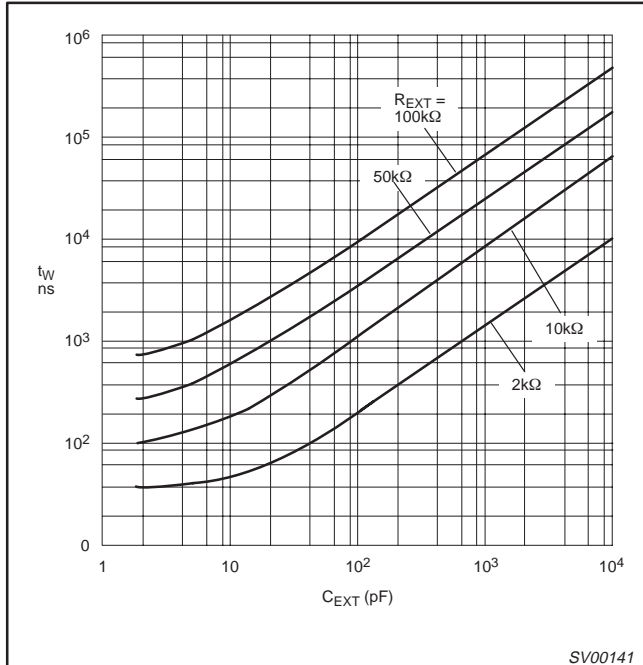

Figure 5. Typical output pulse width as a function of the external capacitor values at $V_{CC} = 3.3\text{V}$ and $T_{amb} = 25^\circ\text{C}$.

APPLICATION INFORMATION

Power-up considerations

When the monostable is powered-up it may produce an output pulse, with a pulse width defined by the values of R_X and C_X . This output pulse can be eliminated using the circuit shown in Figure 6.

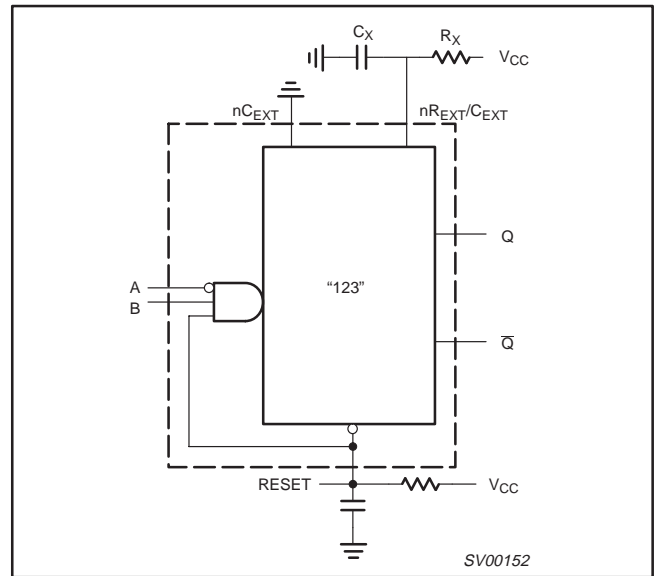

Figure 6. Power-up output pulse elimination circuit

Power-down considerations

A large capacitor (C_X) may cause problems when powering-down the monostable due to the energy stored in this capacitor. When a system containing this device is powered-down or a rapid decrease of V_{CC} to zero occurs, the monostable may sustain damage, due to the capacitor discharging through the input protection diodes. To avoid this possibility, connect a damping diode (D_X) preferably a germanium or Schottky type diode able to withstand large current surges as shown in Figure 7.

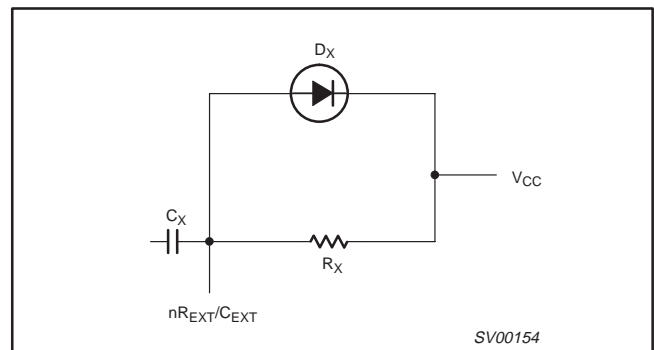

Figure 7. Power-down protection circuit

Dual retriggerable monostable multivibrator with reset

74LV123

TEST CIRCUIT

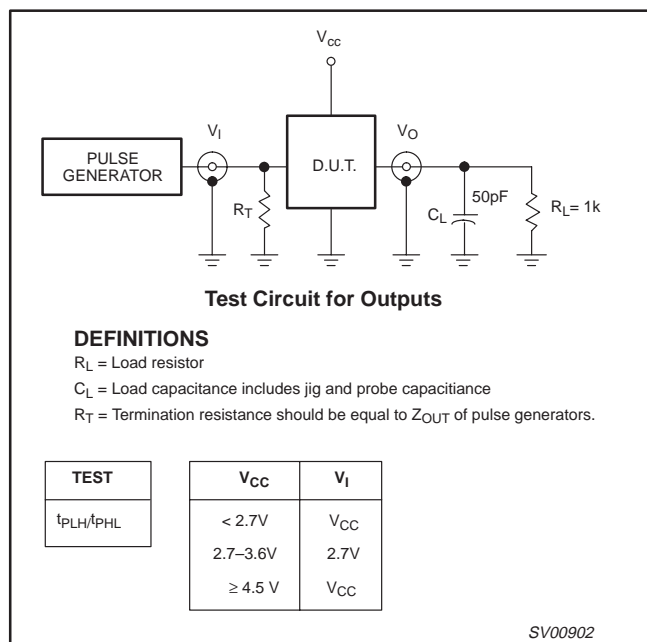

Figure 8. Load circuitry for switching times

Dual retriggerable monostable multivibrator with reset

74LV123

DIP16: plastic dual in-line package; 16 leads (300 mil); long body

SOT38-1

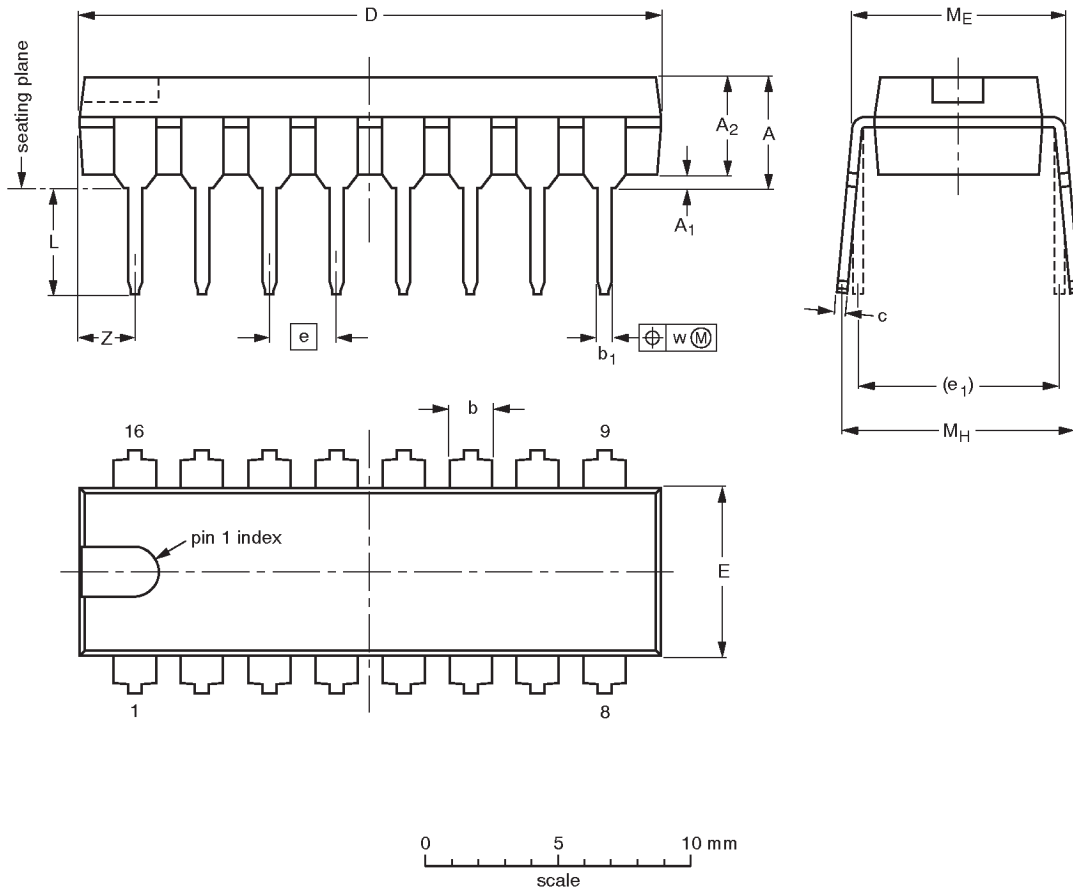

DIMENSIONS (inch dimensions are derived from the original mm dimensions)

UNIT	A max.	A ₁ min.	A ₂ max.	b	b ₁	c	D ⁽¹⁾	E ⁽¹⁾	e	e ₁	L	M _E	M _H	w	Z ⁽¹⁾ max.
mm	4.7	0.51	3.7	1.40 1.14	0.53 0.38	0.32 0.23	21.8 21.4	6.48 6.20	2.54	7.62	3.9 3.4	8.25 7.80	9.5 8.3	0.254	2.2
inches	0.19	0.020	0.15	0.055 0.045	0.021 0.015	0.013 0.009	0.86 0.84	0.26 0.24	0.10	0.30	0.15 0.13	0.32 0.31	0.37 0.33	0.01	0.087

Note

1. Plastic or metal protrusions of 0.25 mm maximum per side are not included.

OUTLINE VERSION	REFERENCES				EUROPEAN PROJECTION	ISSUE DATE
	IEC	JEDEC	EIAJ			
SOT38-1	050G09	MO-001AE				92-10-02 95-01-19

Dual retriggerable monostable multivibrator with reset

74LV123

SO16: plastic small outline package; 16 leads; body width 3.9 mm

SOT109-1

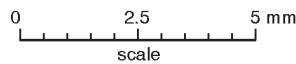
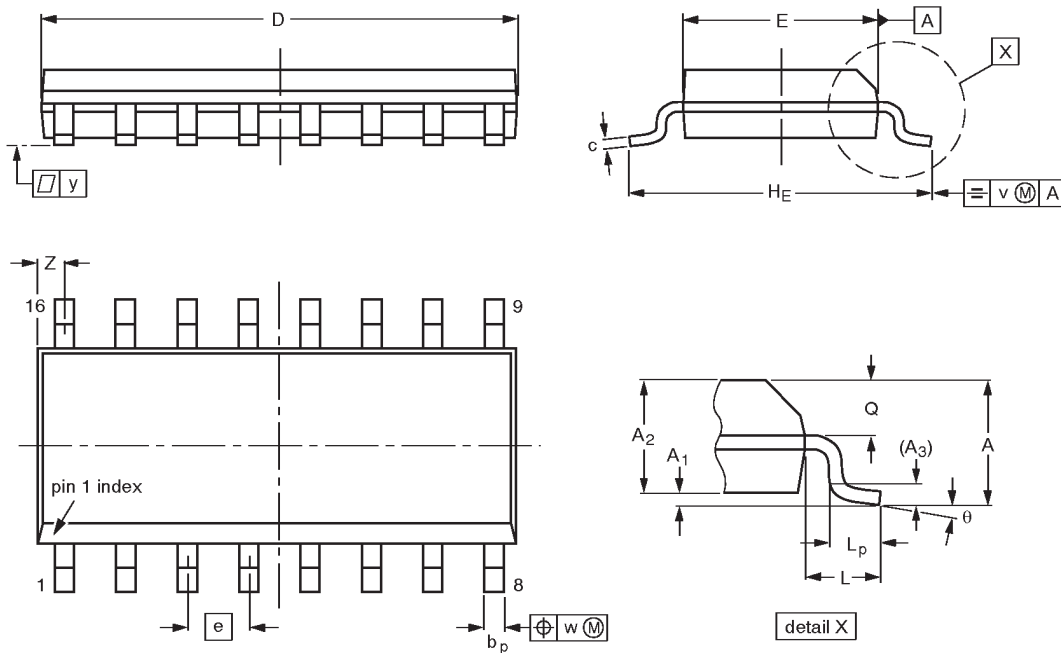

DIMENSIONS (inch dimensions are derived from the original mm dimensions)

UNIT	A max.	A ₁	A ₂	A ₃	b _p	c	D ⁽¹⁾	E ⁽¹⁾	e	H _E	L	L _p	Q	v	w	y	z ⁽¹⁾	θ
mm	1.75	0.25 0.10	1.45 1.25	0.25	0.49 0.36	0.25 0.19	10.0 9.8	4.0 3.8	1.27	6.2 5.8	1.05	1.0 0.4	0.7 0.6	0.25	0.25	0.1	0.7 0.3	8° 0°
inches	0.069	0.0098 0.0039	0.057 0.049	0.01	0.019 0.014	0.0098 0.0075	0.39 0.38	0.16 0.15	0.050	0.24 0.23	0.041	0.039 0.016	0.028 0.020	0.01	0.01	0.004	0.028 0.012	

Note

1. Plastic or metal protrusions of 0.15 mm maximum per side are not included.

OUTLINE VERSION	REFERENCES				EUROPEAN PROJECTION	ISSUE DATE
	IEC	JEDEC	EIAJ			
SOT109-1	076E07S	MS-012AC				91-08-13 95-01-23

Dual retriggerable monostable multivibrator with reset

74LV123

SSOP16: plastic shrink small outline package; 16 leads; body width 5.3 mm

SOT338-1

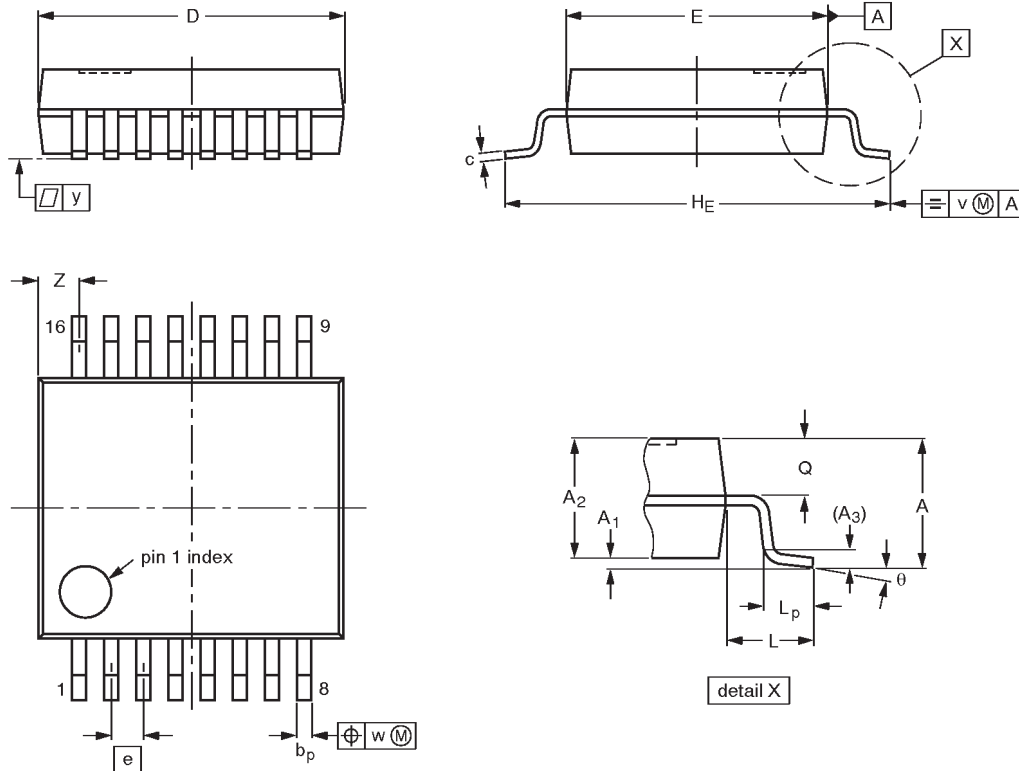

DIMENSIONS (mm are the original dimensions)

UNIT	A max.	A ₁	A ₂	A ₃	b _p	c	D ⁽¹⁾	E ⁽¹⁾	e	H _E	L	L _p	Q	v	w	y	Z ⁽¹⁾	θ
mm	2.0	0.21 0.05	1.80 1.65	0.25	0.38 0.25	0.20 0.09	6.4 6.0	5.4 5.2	0.65	7.9 7.6	1.25	1.03 0.63	0.9 0.7	0.2	0.13	0.1	1.00 0.55	8° 0°

Note

1. Plastic or metal protrusions of 0.25 mm maximum per side are not included.

OUTLINE VERSION	REFERENCES				EUROPEAN PROJECTION	ISSUE DATE
	IEC	JEDEC	EIAJ			
SOT338-1		MO-150AC				94-01-14- 95-02-04

Dual retriggerable monostable multivibrator with reset

74LV123

TSSOP16: plastic thin shrink small outline package; 16 leads; body width 4.4 mm

SOT403-1

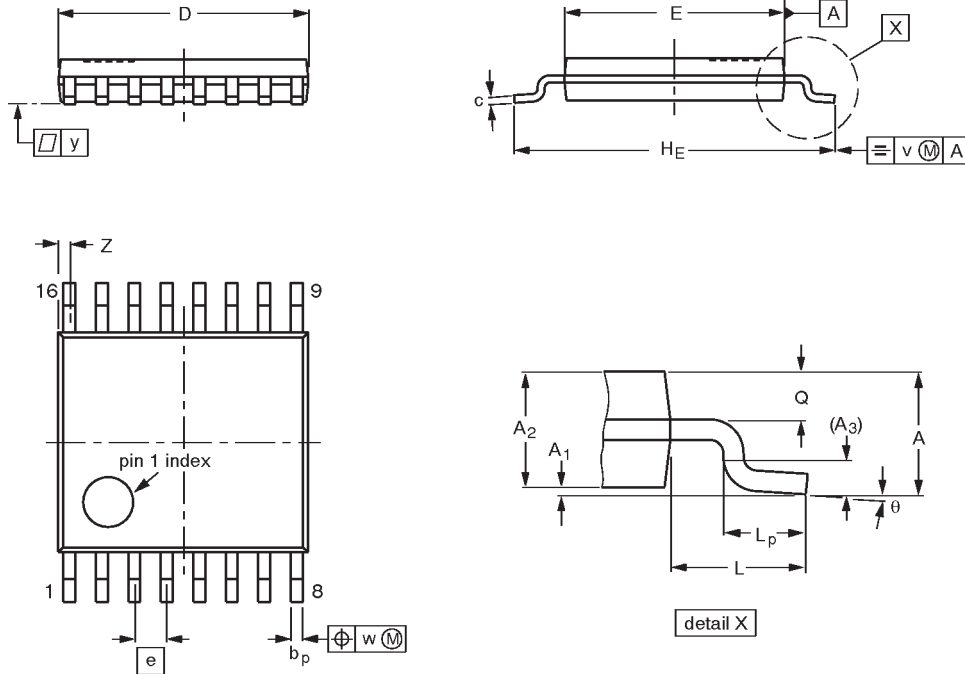

DIMENSIONS (mm are the original dimensions)

UNIT	A max.	A ₁	A ₂	A ₃	b _p	c	D ⁽¹⁾	E ⁽²⁾	e	H _E	L	L _p	Q	v	w	y	Z ⁽¹⁾	θ
mm	1.10	0.15 0.05	0.95 0.80	0.25	0.30 0.19	0.2 0.1	5.1 4.9	4.5 4.3	0.65	6.6 6.2	1.0	0.75 0.50	0.4 0.3	0.2	0.13	0.1	0.40 0.06	8° 0°

Notes

1. Plastic or metal protrusions of 0.15 mm maximum per side are not included.
2. Plastic interlead protrusions of 0.25 mm maximum per side are not included.

OUTLINE VERSION	REFERENCES				EUROPEAN PROJECTION	ISSUE DATE
	IEC	JEDEC	EIAJ			
SOT403-1		MO-153				94-07-12 95-04-04

Dual retriggerable monostable multivibrator with reset

74LV123

DEFINITIONS

Data Sheet Identification	Product Status	Definition
<i>Objective Specification</i>	Formative or in Design	This data sheet contains the design target or goal specifications for product development. Specifications may change in any manner without notice.
<i>Preliminary Specification</i>	Preproduction Product	This data sheet contains preliminary data, and supplementary data will be published at a later date. Philips Semiconductors reserves the right to make changes at any time without notice in order to improve design and supply the best possible product.
<i>Product Specification</i>	Full Production	This data sheet contains Final Specifications. Philips Semiconductors reserves the right to make changes at any time without notice, in order to improve design and supply the best possible product.

Philips Semiconductors and Philips Electronics North America Corporation reserve the right to make changes, without notice, in the products, including circuits, standard cells, and/or software, described or contained herein in order to improve design and/or performance. Philips Semiconductors assumes no responsibility or liability for the use of any of these products, conveys no license or title under any patent, copyright, or mask work right to these products, and makes no representations or warranties that these products are free from patent, copyright, or mask work right infringement, unless otherwise specified. Applications that are described herein for any of these products are for illustrative purposes only. Philips Semiconductors makes no representation or warranty that such applications will be suitable for the specified use without further testing or modification.

LIFE SUPPORT APPLICATIONS

Philips Semiconductors and Philips Electronics North America Corporation Products are not designed for use in life support appliances, devices, or systems where malfunction of a Philips Semiconductors and Philips Electronics North America Corporation Product can reasonably be expected to result in a personal injury. Philips Semiconductors and Philips Electronics North America Corporation customers using or selling Philips Semiconductors and Philips Electronics North America Corporation Products for use in such applications do so at their own risk and agree to fully indemnify Philips Semiconductors and Philips Electronics North America Corporation for any damages resulting from such improper use or sale.

Philips Semiconductors
811 East Arques Avenue
P.O. Box 3409
Sunnyvale, California 94088-3409
Telephone 800-234-7381

© Copyright Philips Electronics North America Corporation 1998
All rights reserved. Printed in U.S.A.

print code

Date of release: 05-96

Document order number:

9397-750-04418

Let's make things better.