

## 10/100BASE-TX/FX OCTAL - $\Phi$ ™ TRANSCEIVER

### BCM5228 FEATURES

- Single-chip, eight-port Fast Ethernet transceiver
- HP Auto-MDIX
- Low-power 2.5V CMOS technology
- Compatible with 2.5V I/O and 3.3V I/O
- Reduced Media Independent Interface (RMII)
- Serial Media Independent Interface (SMII)
- Fully integrated digital adaptive equalization
- Up to 150 meters of error-free operation
- Full-duplex support
- Twisted-pair or fiber support on any or all ports
- Interrupt output capability
- 208-pin PQFP or 256-pin FBGA package
- Proven Broadcom proprietary All-DSP Digi- $\Phi$ ™ architecture

### SUMMARY OF BENEFITS

- Target usage: Fast Ethernet switches
- Smallest footprint per port available
- HP Auto-MDIX detects and corrects cabling errors
- Measures 17 mm × 17 mm for eight ports
- Single-chip device contains eight independent Fast Ethernet transceivers
- Performs all physical layer interface functions for 100BASE-TX full- or half-duplex Ethernet on Category 5 unshielded twisted-pair (UTP) cable and 10BASE-T full-duplex or half-duplex Ethernet on Category 3, 4, or 5 UTP cable
- Permits transmission over fiber-optic cabling when paired with an external fiber-optic transceiver
- Compliant with IEEE 802.3 standard
- IEEE 1149.1 (JTAG) scan chain support
- Three LED indicator pins per port
- Onboard cable length meter reports the link distance for each port

### 24-Port 10/100 Switch

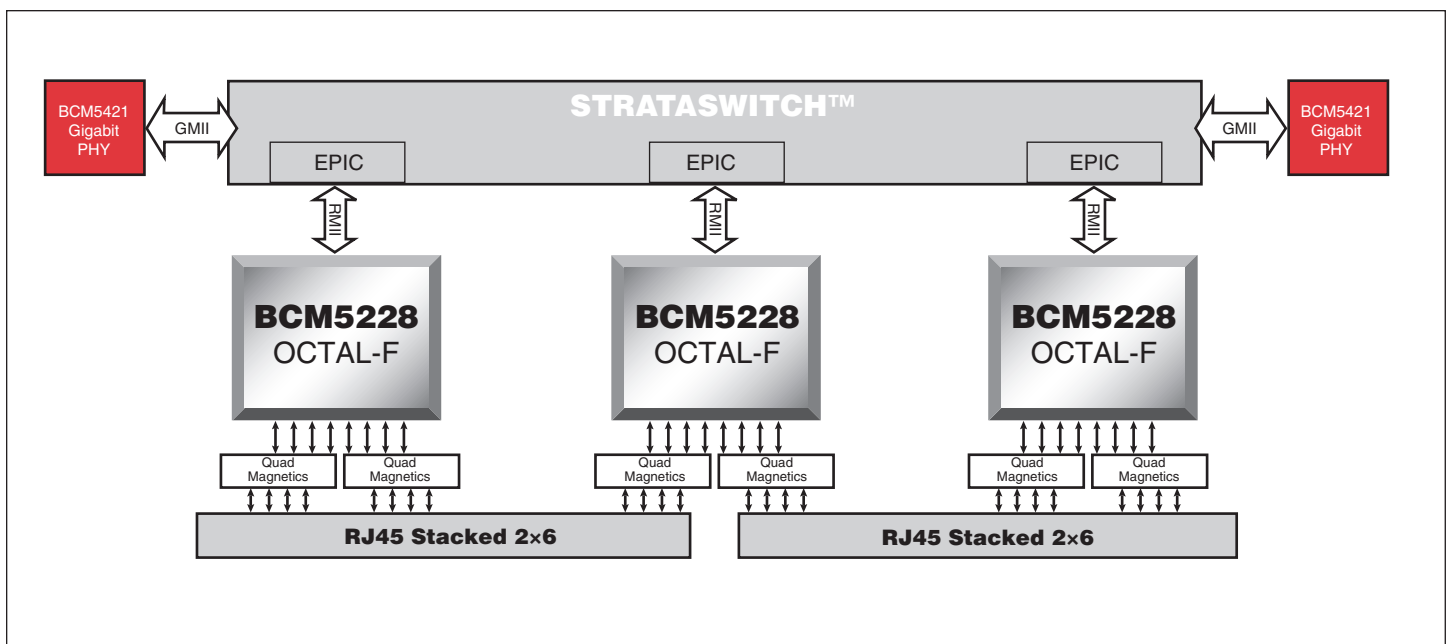

# BCM5228 OVERVIEW

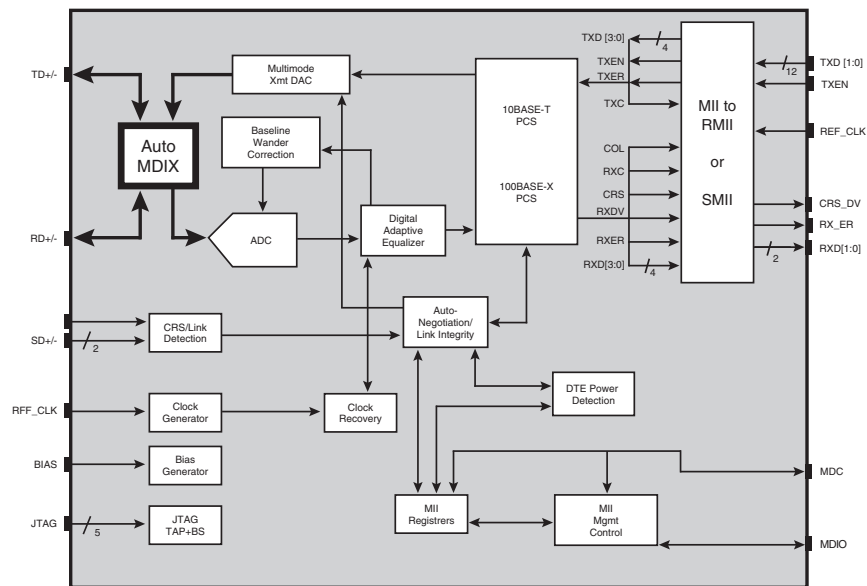

The Broadcom **BCM5228** is a single-chip device containing eight independent Fast Ethernet transceivers. Each performs all the physical layer functions for 100BASE-TX full-duplex or half-duplex Ethernet on Category 5 UTP cable and 10BASE-T full-duplex or half-duplex Ethernet on Category 3, 4, or 5 UTP cable. The **BCM5228** chip performs encoding and decoding, clock and data recovery, digital adaptive equalization, line transmission, carrier sense and link integrity monitoring, auto-negotiation and RMII/SMII management functions. The **BCM5228** complies with the IEEE 802.3 standard.

The **BCM5228** can be connected to a switch controller through the RMII/SMII on one side and to the network media on the other side through isolation transformers for UTP modes or fiber-optic transceiver/receiver components for FX mode. The **BCM5228** operates from a 2.5-V power supply; the I/O operates at either 2.5V or 3.3V.

The **BCM5228** includes support for HP Auto-MDIX, which enables the transceiver to automatically detect and correct miswired cable.

With the HP Auto-MDIX feature, all ports on a switch can be connected to any other 10/100 port on any switch, hub, or network interface card, using crossover or straight-through cables interchangeably. This makes installation, debugging, and maintenance of the network simpler and less expensive to the end user.

The BCM5227 is a version that does not support HP Auto-MDIX.

The BCM5227 and **BCM5228** are offered in three package options. The BCM5227U and BCM5228U are packaged in a 208-pin PQFP and support 10/100 operation over UTP, with three LED indicators per port. The BCM5227F and BCM5228F are packaged in a 208-pin PQFP and support either 10/100 UTP transmission or 100BASE-FX via external fiber-optic transceivers, along with one LED indicator per port. The BCM5227B and BCM5228B are packaged in 256-pin FBGA and support either UTP or fiber on each port, as well as three LED indicators per port. All of these products support both RMII and SMII.

Broadcom®, the pulse logo, Octal-Φ™, Digi-Φ™, StrataSwitch™ and Connecting everything® are trademarks of Broadcom Corporation and/or its subsidiaries in the United States and certain other countries. All other trademarks are the property of their respective owners.

Connecting  
everything®



**BROADCOM CORPORATION**  
16215 Alton Parkway, P.O. Box 57013  
Irvine, California 92619-7013

© 2003 by BROADCOM CORPORATION. All rights reserved.  
5228-PB05-R 04-15-03

Phone: 949-450-8700  
FAX: 949-450-8710  
Email: info@broadcom.com  
Web: www.broadcom.com